

INSTALLATION INSTRUCTION

3.5" Shallow Recessed Housing and Trims

HR-3LED-H20A

WAC LIGHTING
Responsible Lighting®

SAFETY INSTRUCTION

IMPORTANT: NEVER attempt any work without shutting off the electricity.

- Read all instructions before installing.
- System is intended for installation by a qualified electrician in accordance with the National Electrical Code and local regulations.
- Place the wall switch in the "OFF" position.
- Go to the main fuse box, or circuit breaker. Unscrew the fuse(s) or switch "OFF" the circuit breaker switch(es) that control the power to the space that you are working on.

CAUTION:

All parts must be used as indicated in these instructions. Do not substitute any parts, leave parts out, or use any parts that are worn out or broken. Failure to follow this instruction could invalidate the ETL/cETL listing of this fixture.

AVERTISSEMENT

IMPORTANT : COUPEZ L'ÉLECTRICITÉ AVANT TOUTE MANIPULATION.

- Lisez toutes les instructions avant d'installer.
- Système est destiné à être installé par un électricien qualifié en conformité avec le code national de l'électricité et les règlements locaux.
- Placez l'interrupteur mural en position d'arrêt (« OFF »).
- Accédez au panneau central de disjoncteurs ou de fusibles de votre demeure et placez l'interrupteur principal en position d'arrêt (« OFF »).

MISE EN GARDE

Toutes les pièces doivent être utilisées tel qu'il est indiqué dans ces instructions. Ne remplacez pas les pièces, n'en laissez pas de côté et ne les utilisez pas si elles sont usées ou brisées. Le non-respect de ces instructions peut annuler l'homologation ETL/cETL du luminaire.

OVERVIEW:

Housing is new construction Non-IC, AIRTIGHT. Housing requires a trim. Please check the website for compatible trim choices.

HOUSING INSTALLATION:

1. Install housing using two hanger bars provided, align the bottom of the hanger bar with the bottom of the wood joist. Secure the "screw-nail" on each end by screw-driver or by hammer(See FIG.1 detail A). Slide fixture along hanger bar into desired location, use locking screws to secure (See FIG.1 detail B). For grid installation, hanger bars should be supported on grids. (See FIG.2)
2. To shorten hanger bars to fit in a shorter distance, snap off one or more sections of the hanger bars (See FIG.3).
3. Remove spring latched junction box cover and connect fixture wires to building wires: insert each supply wire into appropriate junction box connector. Connect black fixture wire to hot, white fixture wire to neutral and green fixture wire to ground (See FIG.4). Place all wiring and connectors back in junction box and replace the junction box's cover.

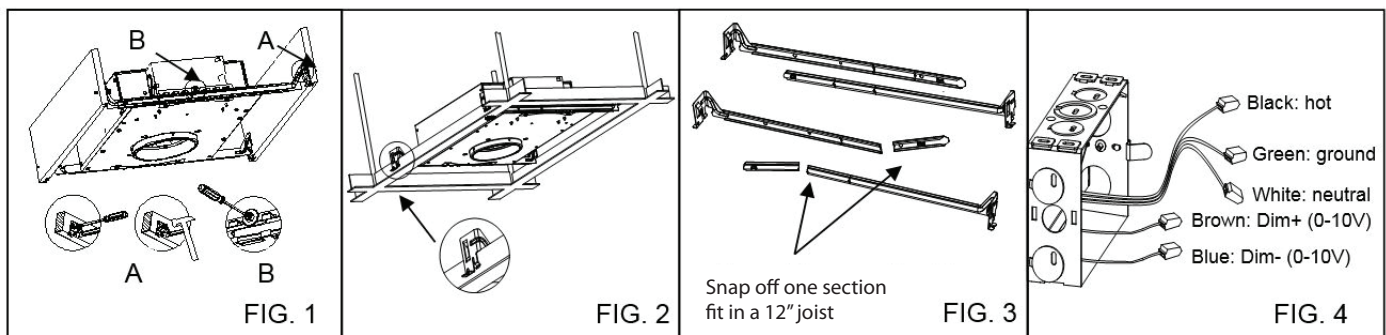

WAC Lighting
www.waclighting.com
Phone (800) 526.2588 • Fax (800) 526.2585

Headquarters/Eastern Distribution Center
44 Harbor Park Drive • Port Washington, NY 11050
Phone (516) 515.5000 • Fax (516) 515.5050

Western Distribution Center
1750 Archibald Ave • Ontario, CA 91761
Phone (800) 526.2588 • Fax (800) 526.2585

INSTALLATION INSTRUCTION

3.5" Shallow Recessed Housing and Trims

HR-3LED-H20A

WAC LIGHTING
Responsible Lighting®

TRIM INSTALLATION

1. Raise the trim to housing, depress trim spring clips and push the trim assembly up until the trim ring is flush to the ceiling (See FIG.5 and FIG.6).

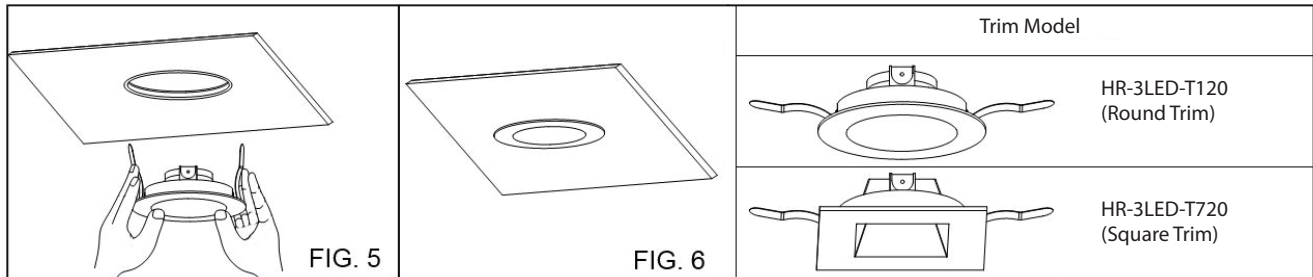

INVISIBLE TRIM INSTALLATION

1. Raise the invisible trim frame aligning tab to slot in housing, and put plastic shield inside (See FIG.7).
2. Secure the invisible trim frame to the housing, flush up against the ceiling using the screws supplied (See FIG.8).
3. Apply plaster or spackle over Invisible frame and sand surface when dry for a finished look (See FIG.9).
4. Remove the plaster shield when finishing is completed (See FIG.10).
5. Raise the invisible trim assembly up to the trim frame until the trim ring is flush to the trim frame (See FIG.11).

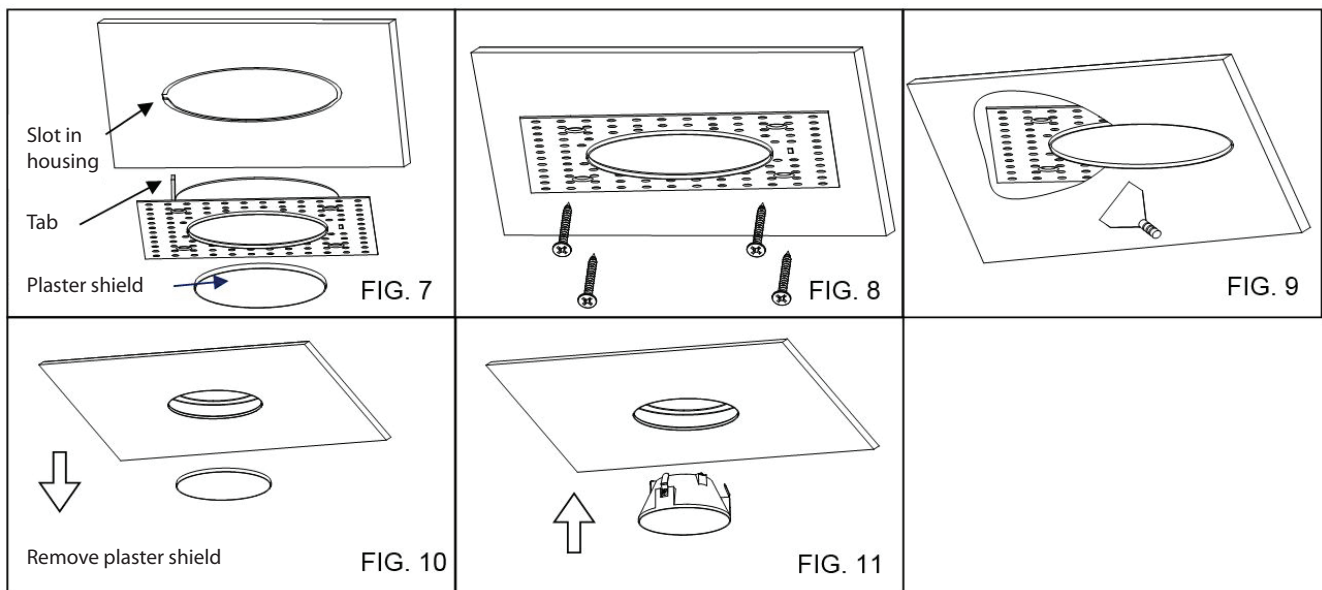

INVISIBLE TRIM MODEL

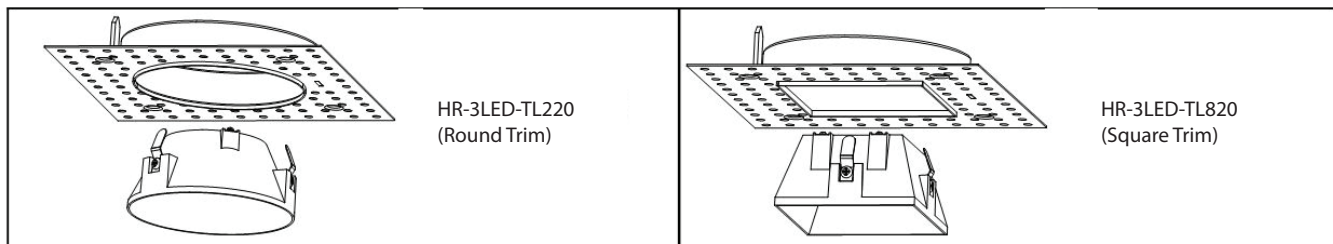

WAC Lighting
www.waclighting.com
Phone (800) 526.2588 • Fax (800) 526.2585

Headquarters/Eastern Distribution Center
44 Harbor Park Drive • Port Washington, NY 11050
Phone (516) 515.5000 • Fax (516) 515.5050

Western Distribution Center
1750 Archibald Ave • Ontario, CA 91761
Phone (800) 526.2588 • Fax (800) 526.2585

INSTALLATION INSTRUCTION

3.5" Shallow Recessed Housing and Trims

WAC LIGHTING
Responsible Lighting®

HR-3LED-H20A

LED AND DRIVER REPLACEMENT

1. Remove the trim or invisible trim
 - a. Remove the trim or invisible trim as shown below (See FIG.12 & 13).

To remove trim:

Remove the trim by pulling the trim's edge

To remove invisible trim:

Remove the invisible trim by gently prying between the invisible trim and lens

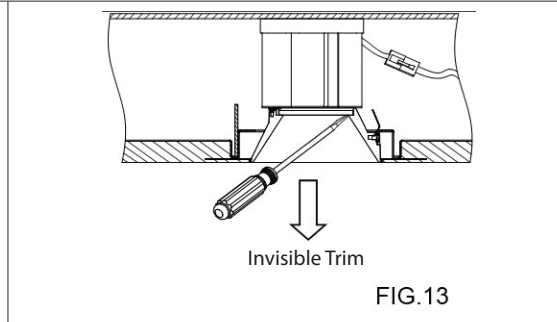
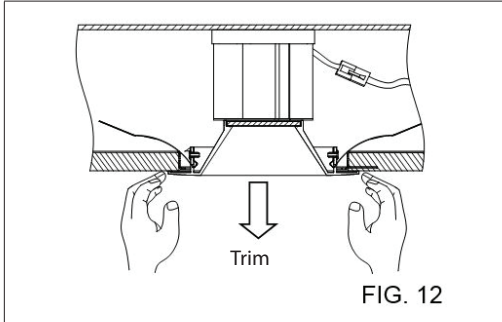

2. Replace LED
 - a. Disconnect wire connector, rotate the LED module counterclockwise and pull out to remove the LED module from housing (See FIG.14).
 - b. Replace the LED by unscrewing the bracket, removing lens and reflector. Then, replace the LED (See FIG.15 & 16).

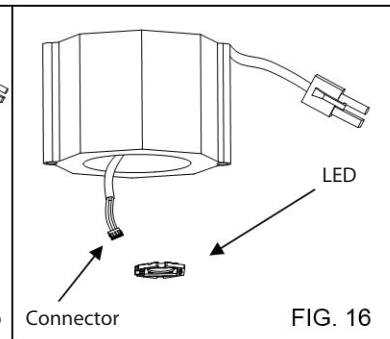
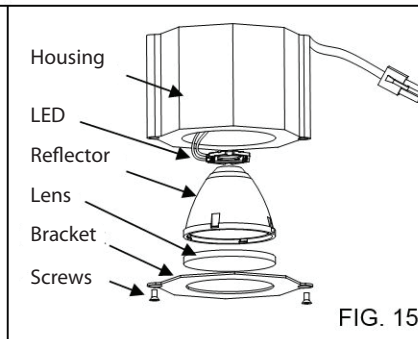
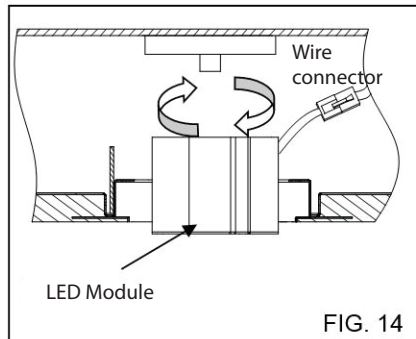

3. Replace Driver
 - a. Remove the LED module first (See step 2 and FIG.14), then, loosen wing nuts on the side of driver (See FIG.17).
 - b. Tilt driver downward and remove from housing (See FIG.18).
 - c. Remove screws to replace driver with new, rewire according to code and reinstall (See FIG.19).

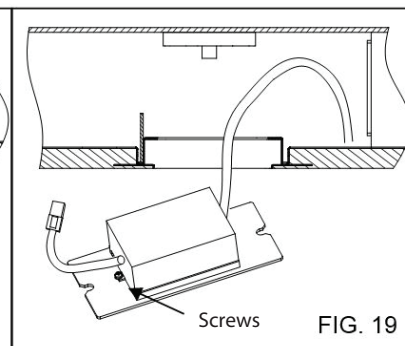
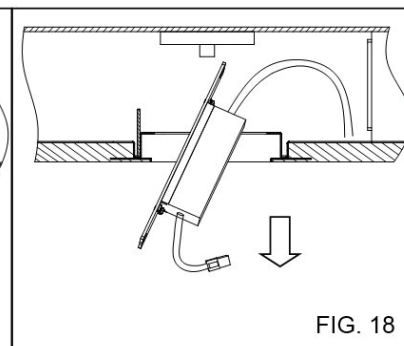
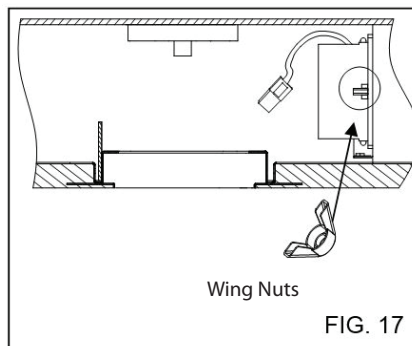

WAC Lighting
www.waclighting.com
Phone (800) 526.2588 • Fax (800) 526.2585

Headquarters/Eastern Distribution Center
44 Harbor Park Drive • Port Washington, NY 11050
Phone (516) 515.5000 • Fax (516) 515.5050

Western Distribution Center
1750 Archibald Ave • Ontario, CA 91761
Phone (800) 526.2588 • Fax (800) 526.2585