

Assembly instructions

Instructions d'assemblage

We're here to help - Do not return this product !

Call, email or find us online first !

- If you need help with assembly
- If you received a damaged or defective part
- If you are missing hardware

We will process replacement parts in 3-5 business days or less. Parts are shipped via FedEx Ground or mail.

Nous sommes là pour vous - Ne retournez pas ce produit !

Appelez, écrivez ou trouvez-nous en ligne d'abord !

- *Si vous avez besoin d'aide avec l'assemblage*
- *Si vous avez une pièce manquante ou endommagée*
- *S'il vous manque de la quincaillerie*

Nous vous enverrons les pièces de rechange dans un délai de 3 à 5 jours ouvrables, ou moins. Les pièces sont expédiées via FedEx Ground ou par la poste.

Online resources

Ressources disponibles en ligne



How-to videos

Vidéos d'aide



FAQ's

Questions fréquentes



Order replacement parts

Commande de pièces de remplacement

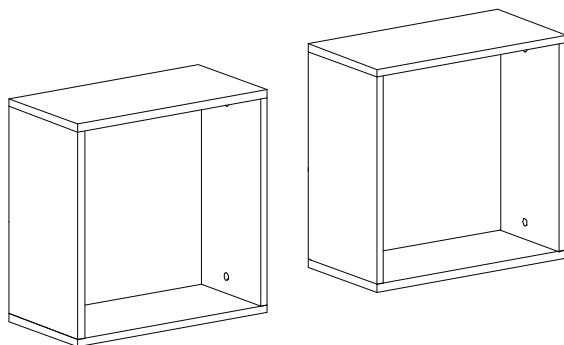

Weight capacity : 25 lb per unit
Poids maximal par unité : 25 lb

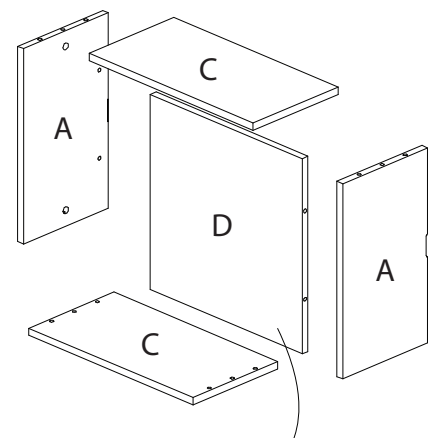

Optionnal installation of the back panel D

*Installation optionnelle
du panneau de dos D*

Read these assembly instructions carefully before beginning. Verify that you have in hands all the wood parts and hardware. Keep this document for future reference.

Lisez attentivement ce guide d'assemblage avant de débiter. Assurez vous que toutes les composantes de bois et de quincaillerie sont présentes. Conservez ce document.

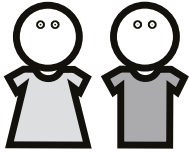

Two people are required to assemble and move this unit.
Deux personnes sont requises pour assembler et déplacer ce meuble.



Safety First! Do not allow children to climb on or play with furniture.
Attention! Ne permettez pas aux enfants de jouer ou grimper sur les meubles.

Never leave liquids or damp clothes on your furniture. Never use chemical product to clean your furniture. Do not place your furniture in direct sunlight.

To clean your furniture, dampen a soft cloth with a mild solution of dishwashing liquid. Squeeze excess water. Clean unit and wipe it dry.



Ne jamais laisser de liquide ou de linge humide sur votre meuble. Ne jamais utiliser de produits chimiques pour nettoyer votre meuble. N'exposez pas votre meuble à la lumière directe du soleil.



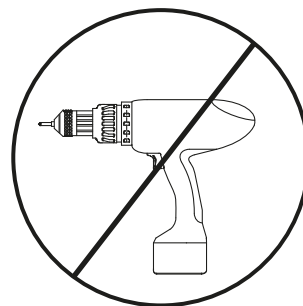
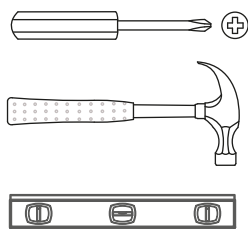

Pour nettoyer votre meuble, trempez un chiffon doux dans une faible solution de liquide pour la vaisselle et d'eau. Bien essorer. Nettoyez le meuble et essuyez soigneusement le surplus d'eau avec un linge sec.

Tools required
Outils requis

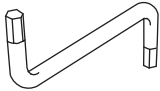
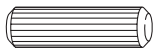
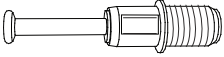
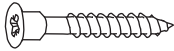

Hardware List

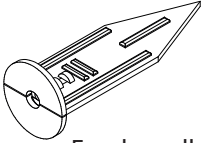
Liste de quincaillerie

<p>8x # 0203</p> 	<p>1x # 2300</p> 	<p>24x # 0207</p> 
<p>8x # 2200</p> 	<p>8x # 0113</p> 	<p>16x # 2194</p> 
<p>4x # 2207 For drywall only Pour gypse seulement</p> 	<p>4x # 0108</p> 	<p>4x # 2126</p> 

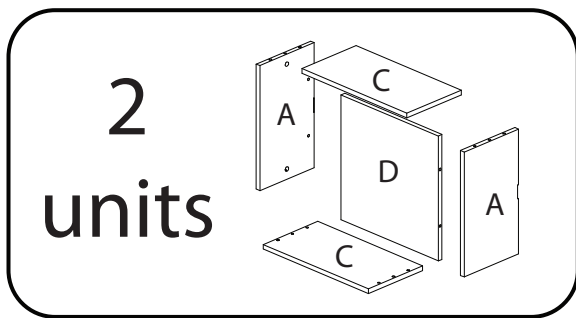

OR
OU

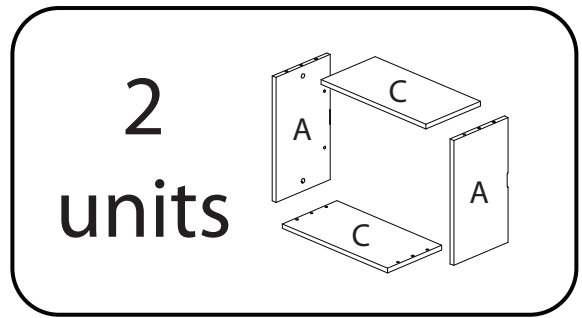

Page 6

1 Insert 4 cam locks # 0203 into the 2 panels A
Insérez 4 excentriques # 0203 dans les 2 panneaux A

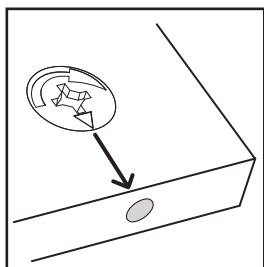

Press firmly into the hole
Pressez fermement dans la cavité

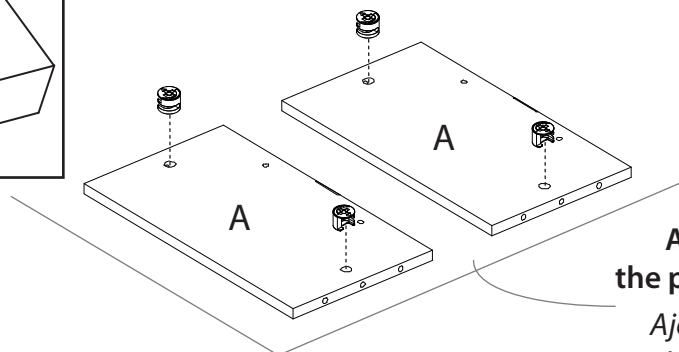

Add a protection under the parts on all assembly steps
Ajoutez une protection sous les pièces à chaque étape

2 Install 4 push bolts # 2200 into the 2 panels C. Then, softly insert 12 wood dowels # 0207 into the 2 panels A and the 2 panels C

Installez 4 boulons # 2200 dans les 2 panneaux C. Insérez ensuite doucement 12 goujons de bois # 0207 dans les 2 panneaux A et les 2 panneaux C

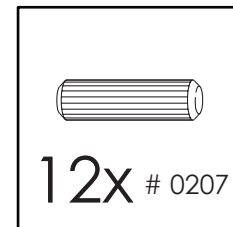
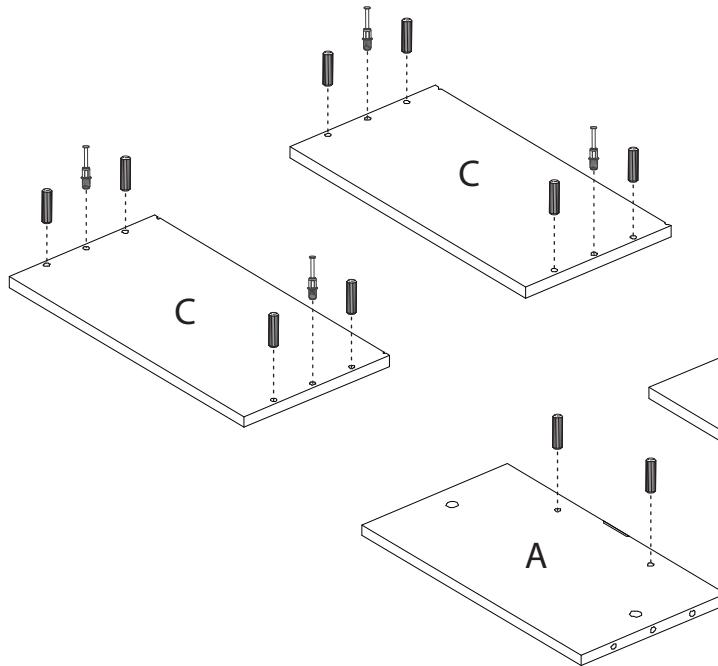
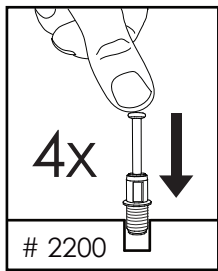

3 Fasten the panel D to the 2 panels A

Assemblez le panneau D avec les 2 panneaux A

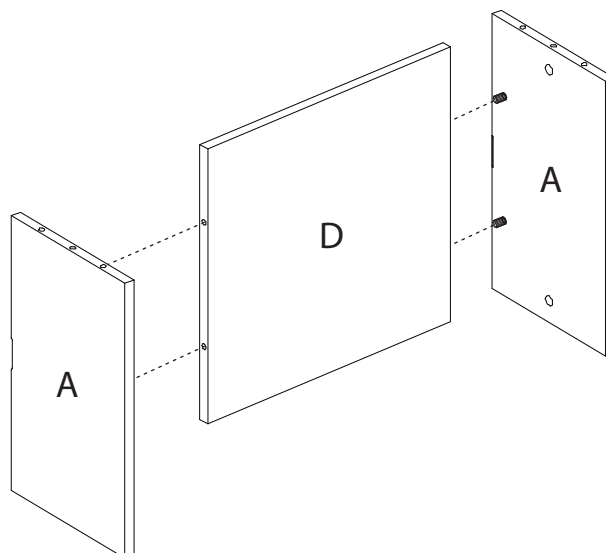

- 4** Fasten the 2 panels C to the pre-assembled panels A-A-D. Then, tighten the 4 cam locks # 0203 located on both panels A. Finalize the step by adding 4 fastcaps # 2194 on the 4 cam locks
Assemblez les 2 panneaux C avec les panneaux pré-assemblés A-A-D. Serrez ensuite les 4 excentriques # 0203 se trouvant sur les 2 panneaux A. Ajoutez 4 capuchons # 2194 sur les 4 excentriques

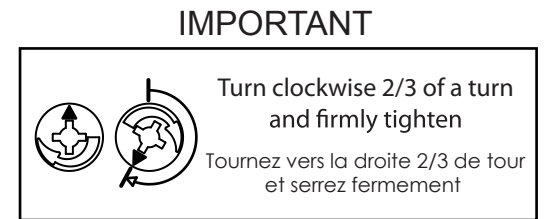
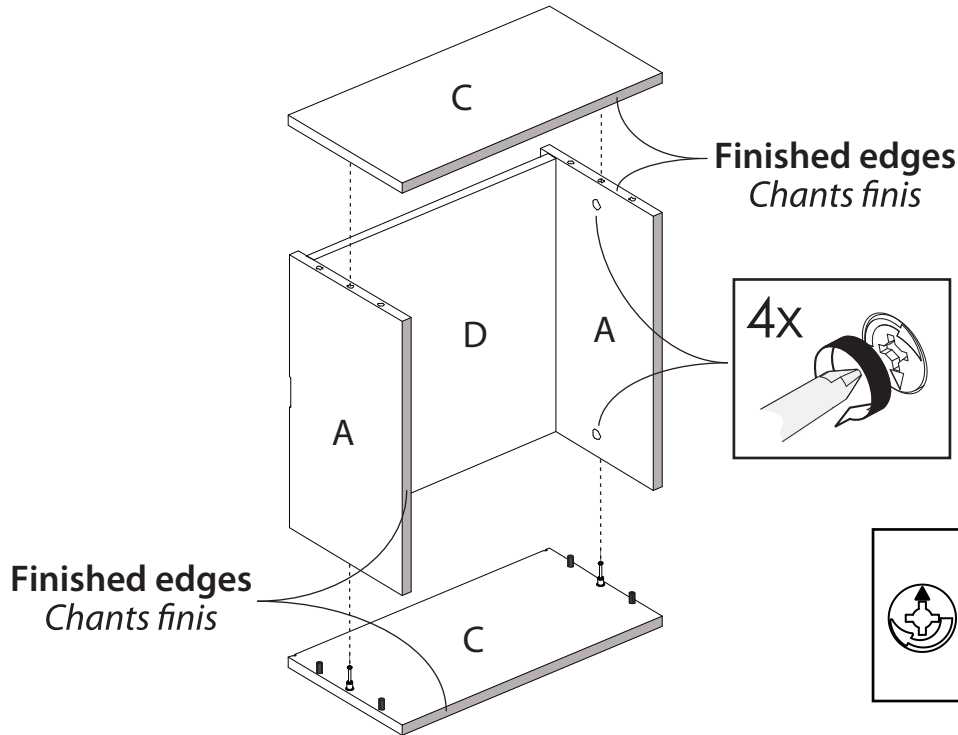

- 5** Use 4 screws # 0113 to fasten 2 keyhole plates # 2126 to the rear edges of panels A. Refer to the pre-drilled holes to locate the plates
Utilisez 4 vis # 0113 pour installer 2 plaques de fixation # 2126 sur les chants arrières des panneaux A. Référez-vous aux perçages pour positionner les 2 plaques de fixation

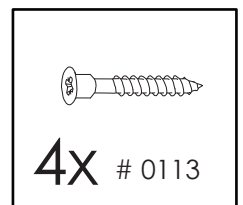
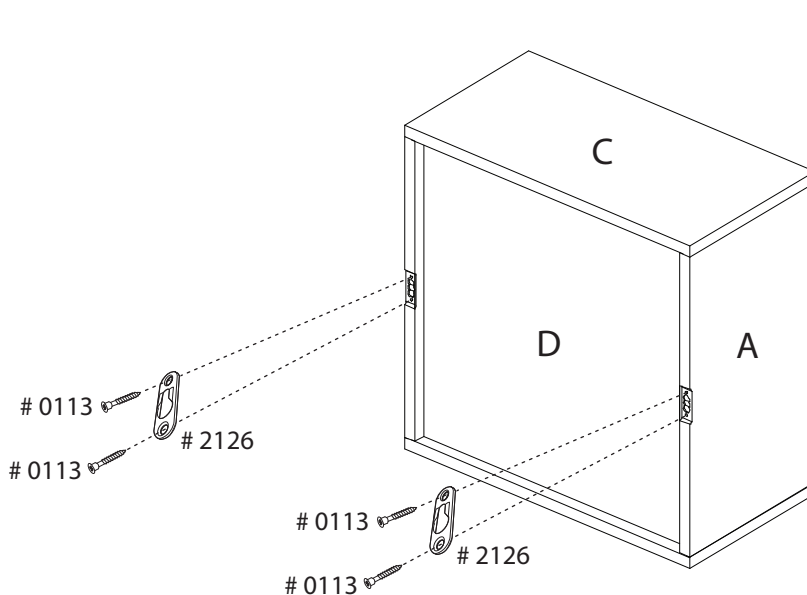

1 Insert 4 cam locks # 0203 into the 2 panels A
Insérez 4 excentriques # 0203 dans les 2 panneaux A

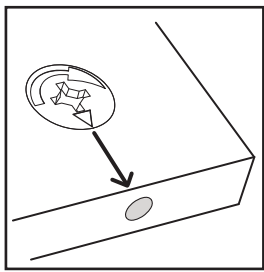

Press firmly into the hole
Pressez fermement dans la cavité

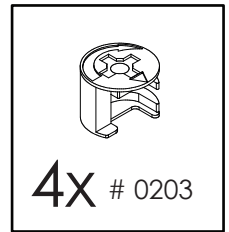
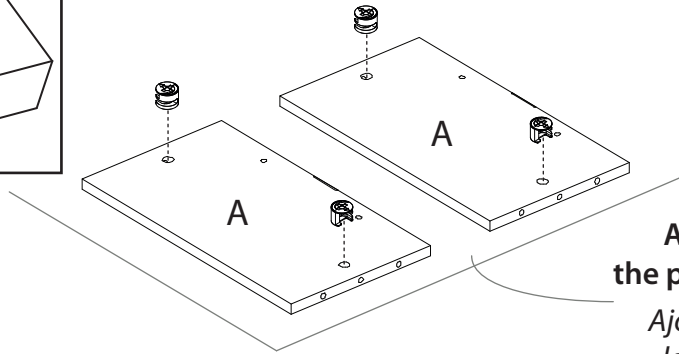

Add a protection under the parts on all assembly steps

Ajoutez une protection sous les pièces à chaque étape

2 Install 4 push bolts # 2200 into the 2 panels C. Then, softly insert 8 wood dowels # 0207 into the 2 panels

Installez 4 boulons # 2200 dans les 2 panneaux C. Insérez ensuite doucement 8 goujons de bois # 0207 dans les 2 panneaux

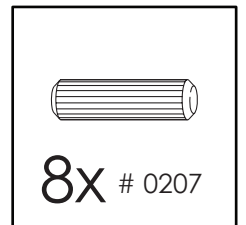
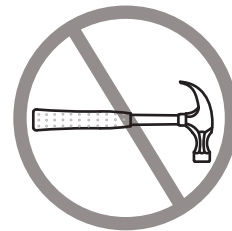
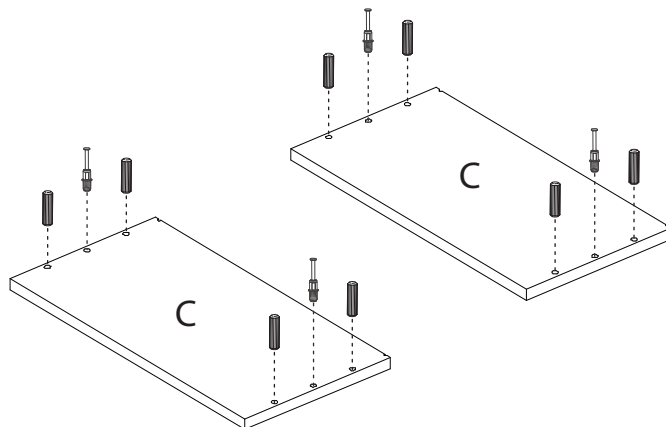
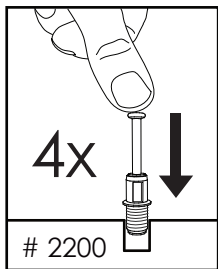

3 Fasten the 2 panels C to both panels A. Then, tighten the 4 cam locks # 0203 located on both panels A. Finalize the step by adding 8 fastcaps # 2194 on the 4 cam locks and the 4 holes
Assemblez les 2 panneaux C avec les 2 panneaux A. Serrez ensuite les 4 excentriques # 0203 se trouvant sur les 2 panneaux A. Ajoutez 8 capuchons # 2194 sur les 4 excentriques et les 4 trous

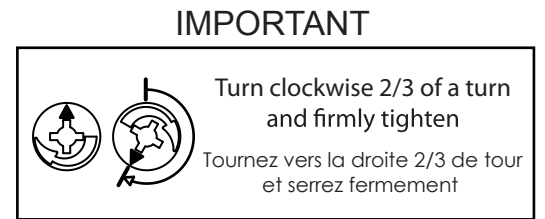
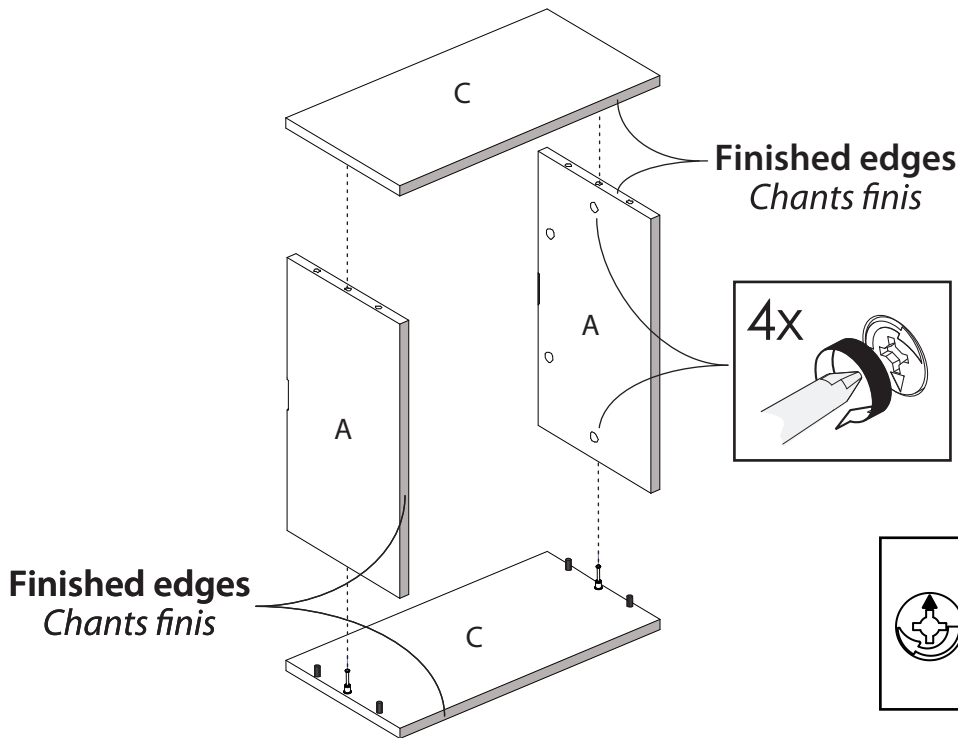

4 Use 4 screws # 0113 to fasten 2 keyhole plates # 2126 to the rear edges of panels A. Refer to the pre-drilled holes to locate the plates
Utilisez 4 vis # 0113 pour installer 2 plaques de fixation # 2126 sur les chants arrières des panneaux A. Référez-vous aux perçages pour positionner les 2 plaques de fixation

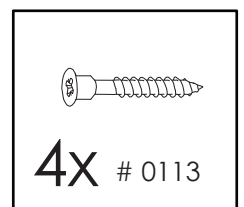
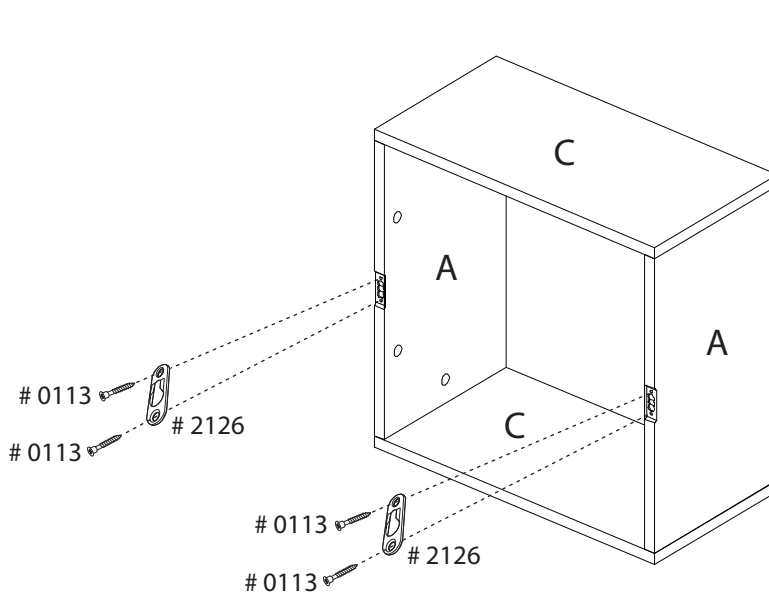

wall installation

Installation murale

1 You first have to set the installation height of the unit. The installation height corresponds to the top of the unit. The 2 wall anchors # 2207 must be installed 8 5/8" (22cm) lower than the installation height (the top)

Vous devez déterminer en premier la hauteur d'installation de chaque unité. Cette hauteur doit correspondre au dessus de l'unité. Les 2 ancrages muraux # 2207 doivent être installés 8 5/8" (22cm) plus bas que la hauteur d'installation (le dessus)

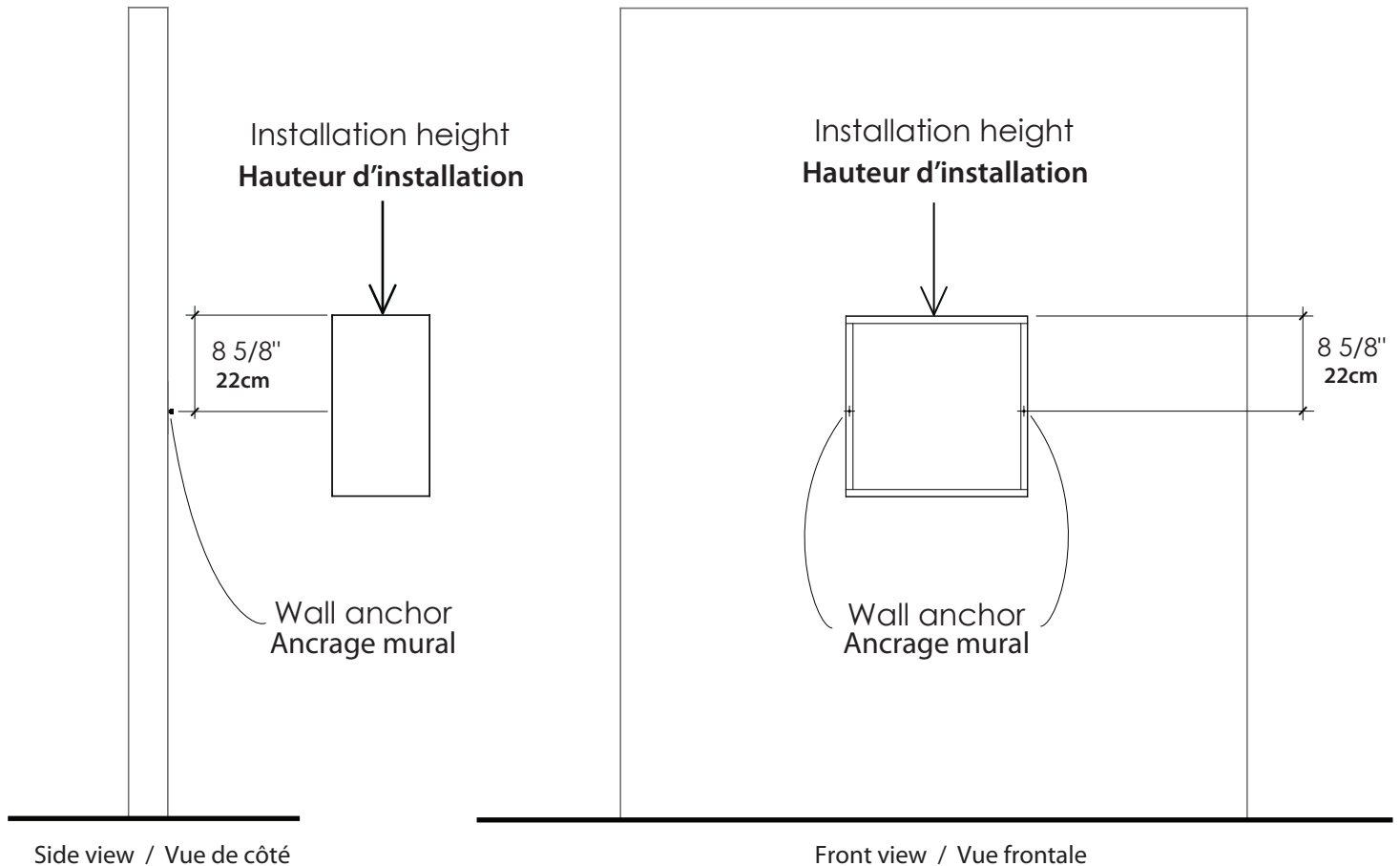

Wall anchors # 2207 are designed to be used only with drywall
Les ancrages muraux # 2207 sont conçus uniquement pour les murs de gypse

2 Once you have set the installation height, you should use the part G as a template to set the final location of the 2 wall anchors # 2207. There is 2 holes on the part G and these holes corresponds to the width of the unit. Use these 2 holes to mark the locations with a pencil

Maintenant que vous avez déterminé la hauteur d'installation, vous devez utiliser la pièce G comme guide afin de déterminer le positionnement final des 2 ancrages muraux # 2207. La pièce G comporte 2 repères qui correspondent à la largeur de l'unité. Utilisez un crayon pour marquer les 2 positions

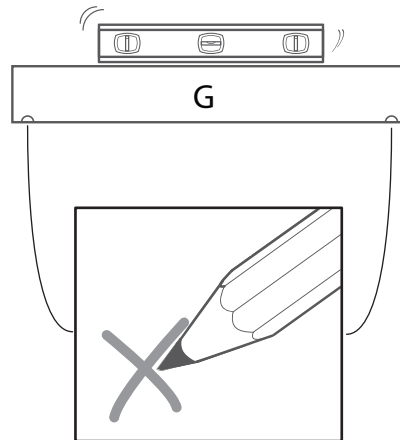

3 Use a hammer to knock in the 2 wall anchors # 2207 into the wall. Then, insert 1 screw # 0108 in each anchor. Leave 1/8" (3mm) between the head of the screw and the wall to allow the unit to hang properly. Align the keyhole # 2126 located at the back of the unit with the 2 anchors on the wall

Utilisez un marteau pour installer les 2 ancrages muraux # 2207 dans le mur. Insérez ensuite une vis # 0108 dans chaque ancrage en prenant soin de laisser la vis dépasser de 1/8" (3mm). Cela facilitera l'accrochage de l'unité. Alignez finalement les 2 plaques de montage # 2126 situées à l'arrière de l'unité avec les 2 ancrages

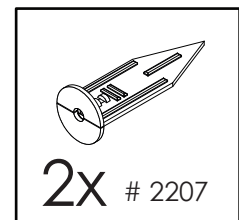
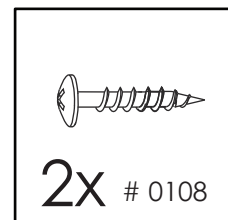
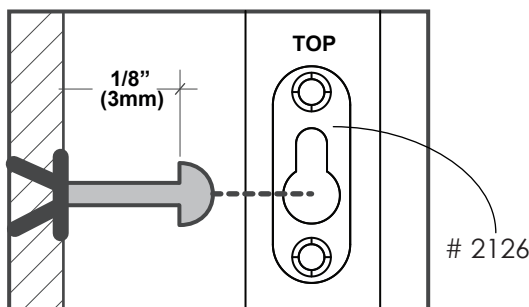

Repeat all the steps for the second rectangle
Répétez toutes les étapes pour le deuxième rectangle

Limited 1 Year Warranty

All our products are warranted to the original purchaser against defects in material or workmanship for a period of 1 year from the date of purchase.

“Defects” as used in this warranty is defined as any imperfections that may impair the use of the furniture or product for which it was intended to.

This warranty is expressly limited to the replacement of defective furniture parts and/or components, subject to availability of stock. Assembly labor is excluded.

This warranty applies under conditions of normal use. It does not cover defects caused by improper assembly or disassembly, product modification, intentional damage, abuse, misuse, accidents, negligence or exposure to the elements. Our furniture products are not intended for outdoor use.

This warranty is only applicable in Canada and the USA.

This warranty is explicit on the limits of our liability and entitles the original purchaser to specific rights. Any warranty defined by law in your state/province is limited to 1 year. Should the law in your state or province differ from the above, it will not apply