



Outdoor  
Living Today

# ASSEMBLY MANUAL

## 8x12 Sunshed Garden Shed

Stock Code:

SSGS812-AK/FJ/-CEDAR

SSGS812-AK/FJ/-METAL

SSGS812-AK/FJ/-PLY

Version #1.3

Nov 5, 2025



### CONTACT

#### ADDRESS

9393 287th Street,  
Maple Ridge, British Columbia,  
Canada V2W 1L1

#### PHONE & FAX

Toll Free: 1-888-658-1658

Fax:

#### ONLINE

Email: [olmsupport@outdoorlivingtoday.com](mailto:olmsupport@outdoorlivingtoday.com)

Web: [www.outdoorlivingtoday.com](http://www.outdoorlivingtoday.com)

# What You Need to Know

---

Thank you for purchasing a 8x12 Sunshed.

*Please take the time to identify all the parts prior to assembly.*

## IMPORTANT INFORMATION

It is the sole responsibility of the customer to check with your local municipal or county by-laws before ordering this product to confirm it complies with building codes in your area.

If the product is elevated, any structural and building code requirements are solely the customer's responsibility, and should be abided by.

Snow load ratings vary by geographical location. If heavy or wet snowfall occurs, it is advisable to sweep snow off roof frequently. In areas with high or gusty wind conditions, it is advisable to install the structure securely to the ground.

Have a regular maintenance plan to ensure screws, doors, windows and parts are tightly affixed.

All structures purchased from Outdoor Living Today are covered for a period of one year for defects in manufacturing and workmanship. Costs incurred for customer installations are not included.

*Failure to use supplied parts included in this kit could result in poor product performance and may void your warranty. Please contact Outdoor Living Today's Customer Toll Free Line if you plan to deviate from our written instructions.*

## Warranty

---

In the event of a missing or broken piece, please contact Outdoor Living Today Customer Support at [olmsupport@outdoorlivingtoday.com](mailto:olmsupport@outdoorlivingtoday.com) within 30 days of the delivery of your purchase. It is our commitment to you to courier replacement parts, free of charge, within 10 business days of this notification. Replacement parts will not be provided free of charge after the 30 day grace period.

Customer agrees to hold Outdoor Living Today and any Authorized Dealers free of any liability for improper installation, maintenance and repair.

# What to do Before my Shed Arrives?



Become familiar with this assembly manual and determine if you can complete the project yourself or will require a professional contractor.



One helper is recommended to assist in constructing your shed. It generally takes two people two days to assemble a shed. If you're hiring a contractor, their rate should be in line with that duration of work.



Clear the construction area and ensure a clear pathway for delivery when the freight company arrives. Remove all debris: roots, grass, rocks, etc.



Excavate the site. Contact your local utilities company to ensure there are no gas or electric lines buried in the area before digging.



Decide on the type of foundation you will be using: Concrete slab, or 4-6 inches of crushed gravel with paver stones or 4x4 stringers.

You can find the footprint for your shed on Page 3 of your Assembly Manual.



If doing the assembly yourself, have all the necessary tools ready to go and in working condition. A list of required tools can be found after the parts list.

## Foundation Types for 8x12 Garden Shed

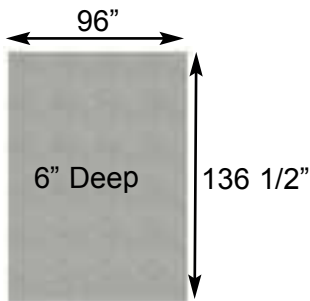

**Concrete Foundation**

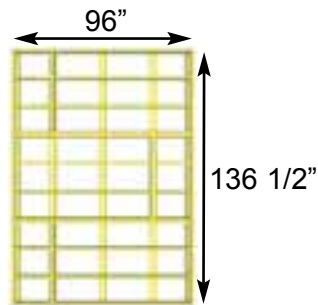

**Floor Frame**



**Completed Foundation**

### Concrete Slab Foundation:

- Slab must be at least the same size as assembled floor frame (136 1/2" x 96") or larger.
- 6" Deep foundation.
- 1.7 Cubic Yards of concrete required.
- A concrete slab will have the longest durability out of your foundation options.

**Once level, a concrete slab is the easiest surface to build on.**

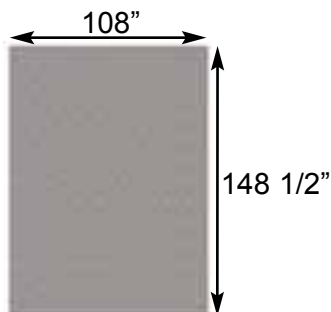

**Gravel Foundation**

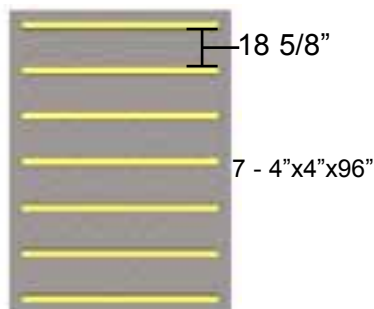

**Gravel Foundation with treated stringers**

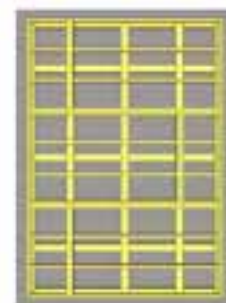

**Completed Foundation**

### Gravel with 4x4 Pressure Treated Stringers:

- Excavate at least 6" deep, and 6" wider than floor frame on each side.
- 2.1 Cubic Yards of gravel required, approximately 19 wheelbarrows.
- 7 - 4x4 Pressure Treated Stringers 8' long required.
- Evenly spaced, with one at each end of floor frame.

**Saves money on materials, easy to level and work with.**

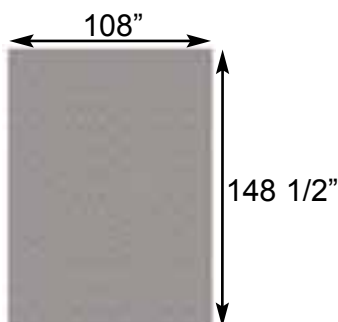

**Gravel Foundation**

25 Patio Stones



**Gravel Foundation with Patio Pavers**

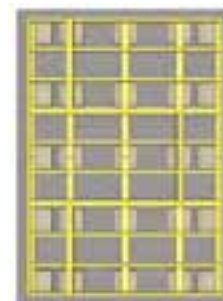

**Completed Foundation**

### Gravel with Patio Paver Stones:

- Excavate at least 6" deep, and 6" wider than floor frame on each side.
- 2.1 Cubic Yards of gravel required, approximately 19 wheelbarrows.
- 25 patio pavers (8" x 8" or larger).
- Center patio paver stones underneath floor runners and underneath seams in floor joists.

**Patio paver stones are widely available from most landscape stores.**

**Thank you for purchasing our 8x12 Sunshed.  
Please take the time to identify all the parts prior to assembly.**

<h1>Parts List</h1>	<h2>Steps</h2> ↓	<h3>D. Roof Section - METAL</h3>	<h2>Steps</h2>
<b>A. Floor Section</b>  <b>Floors</b> 3 - 45 1/2" x 75" - Floor Joist Frames (Interior Joist Unattached) 3 - 45 1/2" x 21" - Floor Joist Frames (Interior Joists Attached) 6 - 1 1/2" x 3 1/2" x 71 3/4" - Floor Joists 3 - 45 3/8" x 74 7/8" - Floor Plywood 3 - 45 3/8" x 20 7/8" - Floor Plywood 10 - 1 1/2" x 3 1/2" x 68 3/16" - Floor Runners	<b>A1 - A12</b>	12 - 3/4" x 3 1/2" x 48 1/4" Outside Roof Battens 6 - 3/4" x 3 1/2" x 45 1/2" Middle Roof Battens 4 - 3/4" x 1 1/2" x 13 1/2" - Batten Spacers Short 4 - 3/4" x 1 1/2" x 13 3/4" - Batten Spacers Long 4 - (39"w x 41") - Metal Roof Panels Short 4 - (39"w x 43") - Metal Roof Panels Long 3 - 60" Long - Metal Ridge Caps	<b>D1 - D16</b>
<b>B. Wall Section</b>  <b>Main Wall Panels</b> 4 - 45 1/2" x 75" - Solid Wall Panels 4 - 1 1/2" x 2 1/2" x 45 1/2" - Wall Plates 2 - 45 1/2" x 75" - Window Wall Panels 3 - 45 1/2" x 75" - Double Window Walls 1 - 12" x 73" - Narrow Wall Panel  <b>Door Jamb, Header &amp; Wall Extenders</b> 1 - 1 1/2" x 3" x 73" - Vertical Door Jamb - AK MODEL 1 - 2" x 3" x 45 1/2" - Door Header - AK MODEL 1 - 1 1/2" x 3 3/8" x 73" - Vertical Door Jamb - FJ MODEL 1 - 2" x 3 3/8" x 45 1/2" - Door Header - FJ MODEL 5 - 45 1/2" x 9" - Wall Extenders 2 - 47 1/2" x 9" - Angle Wall Extenders for Front & Back - L/R  <b>Top Wall Plates</b> 2 - 3/4" x 2 1/2" x 65 3/4" - Short Side - 22 1/2 degree cut on edge 2 - 1 1/2" x 2 1/2" x 65 3/4" - Tall Side - 33 3/4 degree cut on edge 2 - 3/4" x 2 1/2" x 73 3/4" - Front & Rear (33 3/4 degrees on 1 end / 22 1/2 degrees on other)  3 - 3/4" x 3 1/2" x 60" - Horizontal Wall Extender Brace 2 - 3/4" x 3 1/2" x 30" - Horizontal Wall Extender Brace (Front/Back) 1 - 3/4" x 3 1/2" x 71 1/2" - Horizontal Wall Extender Brace (Side)  <b>Gable Walls</b> 2 - Front and Rear Gable Walls - Triangular shaped (33 3/4 degrees on 1 side / 22 1/2 degrees on other)	<b>B1 - B13</b>	<b>D. Roof Section - PLYWOOD</b>  4 - 5/8" x 48" x 37 1/2"- Outer Plywood Roof Panels 2 - 5/8" x 45 1/2" x 37 1/2" - Center Plywood Roof Panels	<b>D1 - D8</b>
<b>C. Rafter Section</b>  9 - 1 1/2" x 3 1/2" x 77 3/4" - Long Roof Side Rafters (22 1/2 degrees) 9 - 1 1/2" x 3 1/2" x 37 3/4" - Short Roof Side Rafters (33 3/4 degrees) 1 - 3/4" x 4 5/8" x 52 1/2" - Ridge Boards (long roof side) 1 - 3/4" x 4 5/8" x 84" - Ridge Boards (long roof side) 1 - 3/4" x 5 1/8" x 52 1/2" - Ridge Boards (short roof side) 1 - 3/4" x 5 1/8" x 84" - Ridge Boards (short roof side) 3 - 3/4" x 3 1/2" x 72 - Gussets (angle cut on both ends) 2 - 1/2" x 3 1/2" x 68 1/4" - Short Roof Side Soffits 2 - 1/2" x 4 1/2" x 68 1/4" - Long Roof Side Soffits 12 - 3/4" x 3/4" x 44 1/2" - Polygal Support Cleats	<b>C1 - C14</b>	<b>D. Polygal Roof Section - CEDAR/METAL/PLYWOOD</b>  4 - 20 1/4"w x 44" - Polygal Panels	<b>D1 - D6</b>
<b>D. Roof Section - CEDAR</b>  2 - 51" x 40 1/2" - Right Side Roof Panels 2 - 45 1/2" x 40 1/2" - Center Roof Panels 2 - 51" x 40 1/2" - Left Side Roof Panels 8 - Long Shingles 4 - Short Shingles 21 - Long Main & 1 - 10" Center Roof Ridge Caps	<b>D1 - D15</b>	<b>E. Misc. Section</b>  <b>Bottom Skirting</b> 10 - 1/2" x 4 1/2" x 45 1/4" - Bottom Skirting  <b>Corner &amp; Wall Trim</b> 2 - 1/2" x 2 1/2" x 75" - Filler Trim Short Wall Side - AK MODEL 2 - 1/2" x 2 1/2" x 84" - Filler Trim Tall Wall Side - AK MODEL 2 - 3/4" x 2 1/2" x 75" - Filler Trim Short Wall Side - FJ MODEL 2 - 3/4" x 2 1/2" x 84" - Filler Trim Tall Wall Side - FJ MODEL 2 - Triangular Gable Trims - (L/R) Found stapled to inside of Gable in each corner - see step E5) 3 - 1/2" x 2 1/2" x 87" - Front Door Trim & Rear Wall Seam Trim 4 - 1/2" x 2 1/2" x 88" - Tall Wall Vertical Trim 4 - 1/2" x 2 1/2" x 79" - Short Wall Vertical Trim 2 - 1/2" x 4 1/2" x 82" - Corner Trim Short Wall Side 2 - 1/2" x 4 1/2" x 87" - Corner Trim Tall Wall Side 1 - 1/2" x 2 1/2" x 32" - Horizontal Door Trim (above Door) 1 - 1/2" x 2 1/2" x 8 3/4" - Horizontal Narrow Wall Trim (above Wall) 2 - 1/2" x 4 1/2" x 85 1/2" - Hor.Gable Trim (F & R) Angle cut 1 end 3 - 1/2" x 2 1/2" x 41 1/2" - Caps for Polygal 2 - 1/2" x 5 1/2" x 41 1/2" - Outside Caps for Polygal (w nailing strip) 2 - 1/2" x 4 1/2" x 41 1/2" - Caps for Polygal  <b>Facia Trim</b> 4 - 3/4" x 1 1/2" x 34" - F&R Facia Nailing Strips 2 - 3/4" x 3 1/2" x 78 3/4" - Angle Cut Front/Rear Facia Trim 2 - 3/4" x 3 1/2" x 38 1/4" - Angle Cut Front/Rear Facia Trim 4 - 3/4" x 3 1/2" x 71 1/2" - Side Facia 2 - Facia Detail Plates (Sides) 2 - Pentagon Detail Plates (Front and Back Facia)  <b>Door System</b> 1 - 31 1/2" x 72" Dutch Door - 2pcs (42" and 30" high) 2 - 1/2" x 2 1/2" x 72" - Interior Vertical Door Stops  <b>Window Inserts/Trim</b> 2 - Reg. Window Inserts 6 - Small Window Inserts 2 - Reg. Window Trim Pkgs: 1 x 24 1/16" Top, 3 x 23" Side & Bottom 6 - Narrow Window Trim Pkgs: 1 x 19 7/8" Top, 2 x 21 7/16" Sides, 1 x 18 3/4" Bottom  <b>Flower Boxes</b> 5 - Flower Box Kits  <b>Potting Shelves</b> 3 - 45" - Long Potting Shelves 1 - 41" - Short Potting Shelf 4 - 1 1/2" x 2 1/2" x 38" - Potting Shelf Legs  <b>**Miscellaneous Pieces</b> 1 pc - Spare Wall Siding 2 pcs - Spare Shingles - use to shim door, etc.	<b>E1</b>  <b>E3 - E13</b>  <b>E14 - E18</b>  <b>E19 - E23</b>  <b>E24 - E25</b>  <b>E26</b>  <b>E27 - E28</b>
<b>Note: Trim and Skirting pieces are graded with the best face being rough sawn. Rough sawn cedar is much easier to paint and stain.</b>		<b>Parts Used in FJ MODEL</b>  6 - 1/2" x 1 1/2" x 45 1/4" - Top Wall Trims - Bevel	<b>E4</b>

# 8x12 SUNSHED HARDWARE SHEET

## Hardware Kit (Provided)

2 1/2"  x 180

2"  x 76

2"  x 20  
Black Headed

1 1/4"  x 228

3/4"  x 22  
Silver

3/4"  x 14  
Black Headed

1 1/2"  x 450  
Finishing

 x 2  
Square Drive Bit

  
33.5° Single Rafter Bracket x2

  
33.5° Double Rafter Bracket x1

  
22.5° Single Rafter Bracket x2

  
22.5° Double Rafter Bracket x1

  
Silicon Caulking

  
Silver Barrel Bolt

  
Black Drop Latch

  
Door Handle

  
Tee Hinge x 4

  
Ridge Board Connector x 2

## Hardware Kit - CEDAR ROOF (Provided)

2 1/2"  x 20

1 1/4"  x 32

1 1/2"  x 12

1"  x 24  
Silver

1 1/2"  x 36  
Shingle

  
90° Metal Brackets x 8

## Hardware Kit - METAL ROOF (Provided)

1 1/4"  x 52

1/4" x 1 1/2"  x 36  
Metal Roof Screw

1"  x 36  
Silver

 x 1  
1/4" Nut Driver

  
Metal Roof Hanger x 3

## Hardware Kit - PLYWOOD ROOF (Provided)

2 1/2"  x 8

1"  x 24  
Silver

1 1/4"  x 68

3/4"  x 12  
Silver

  
90° Metal Brackets x 8

## Tools Required (Not Provided)



Hammer



Screw Gun/Drill



Tape Measure



Wood Clamp



3/8" Wrench



Level



Pliers



Ladder



1/8" & 3/8" Drill Bits



Utility Knife

## Safety Equipment Required (Not Provided)



Safety Glasses



Work Gloves

Assembly Manual shows instructions for the Sunshed with Architect Knotty (AK) Siding and three different roof options. Please proceed to correct roof section depending on your selected roof type after rafter installation. The Parts List shows differences in some part sizes between our different types of siding.



## Before/During Assembly:

- 1.) Paint each face and edge of your plywood floor with a latex exterior paint.
- 2.) Caulk wall seams if gaps appear.
- 3.) Caulk around window framing (if applicable).
- 4.) Caulk perimeter between floor plywood and bottom wall plate.
- 5.) Caulk channels in lap siding at the top of your door above the trim, just a drop in each channel.
- 6.) Caulk edge of door threshold (if applicable).
- 7.) Optional: Install a Sill Gasket between floor runners and foundation.
- 8.) Optional: Install an 8" strip of roofing paper below Cedar Ridge Caps for Cedar Roof Sheds.

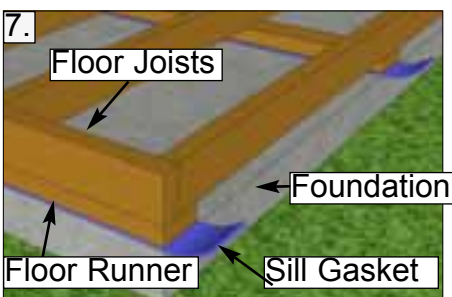
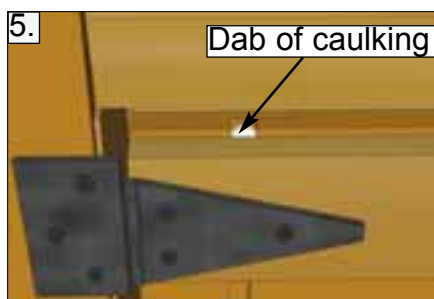
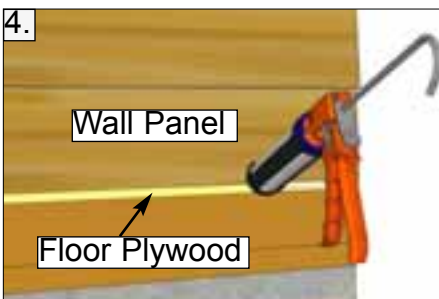
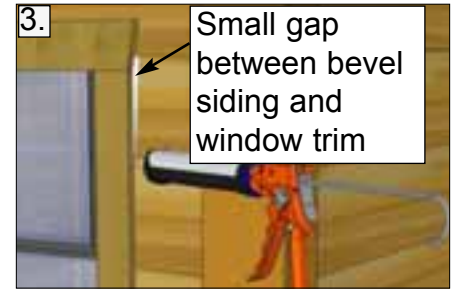
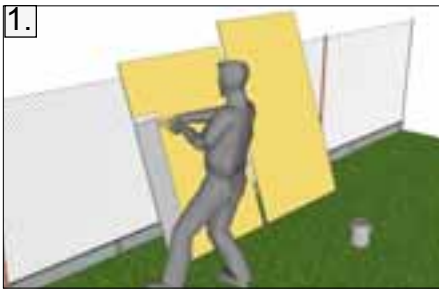

## Routine Maintenance:

- Routinely check all fasteners are tight (ex. Door Hinges, Nails)
- Brush off dirt from walls.
- Brush off snow from roof regularly.
- Routinely remove needles and leaves from roof.

## Painting/Staining

- Your cedar shed, if left untreated, will weather to a silvery grey colour.
- Painting or staining your structure is highly recommended and will prolong the life of your shed.
- You do not need to wait to paint or stain your shed, the wood in your kit has been dried and can be stained or painted immediately.
- Consult your local paint store for the best paint or stain for cedar.
- Optional: stain the inside of your shed. (Note: this will remove the fresh cedar smell.)

# A. Floor Section

Exploded view of all parts necessary to complete Floor Section. Identify all parts prior to starting. Note: Floor Footprint is 96" wide x 136 1/2" deep.

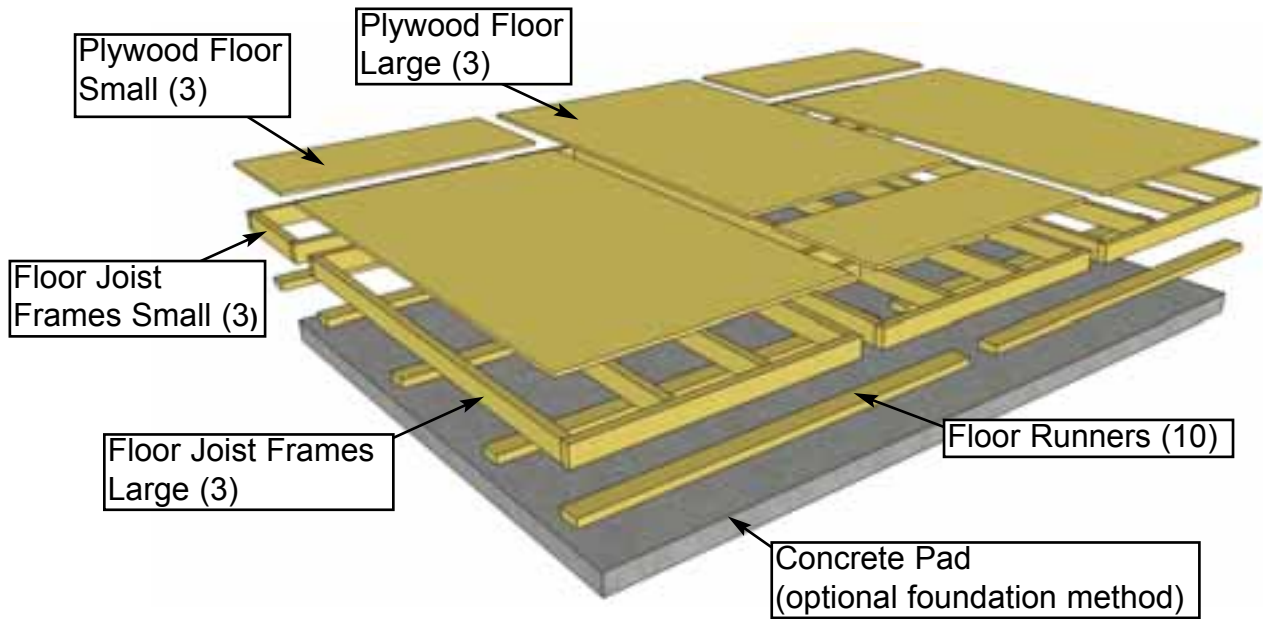

You can find the Square Drive Bit for the screws in with the Hardware Kit Bag.

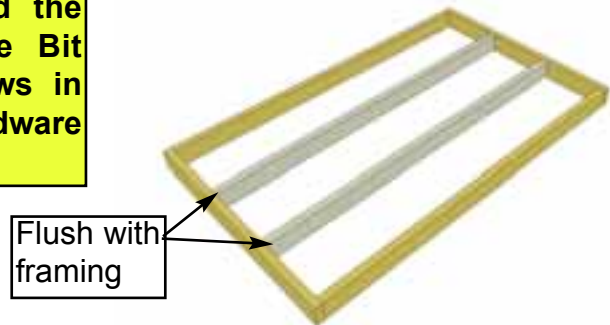

**A1.** Lay out a Large Floor Joist Frame and 2 Floor Joists as illustrated above. Position Joists equally in Floor Joist Frame. Position Joists flush with framing.

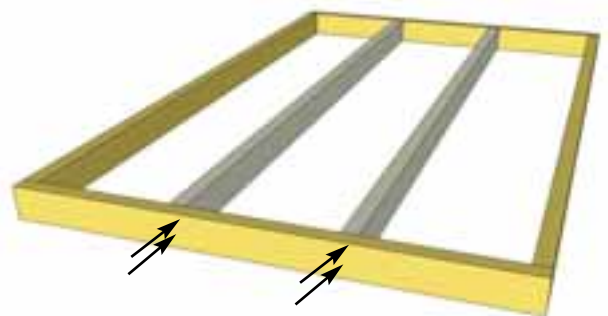

**A2.** Use a Small Floor Joist Frame as a template to determine joist position. When correctly positioned, attach each Joist with 4 - 2 1/2" Screws (2 per end). You can find the Square Drive Bit for the screws in with the Hardware Kit Bag.



**A3.** Lay out completed **Floor Joist Frames** as illustrated. There are 3 larger and 3 smaller Frame Sections. The Footprint for the floor when attached together will be 96" wide x 136 1/2" deep.

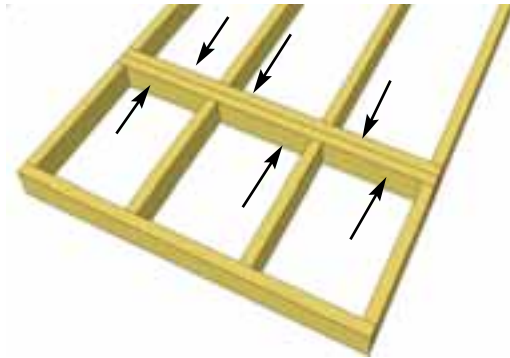

**A4.** Attach each large and small floor joist frame together with 6 - 2 1/2" Screws per section.

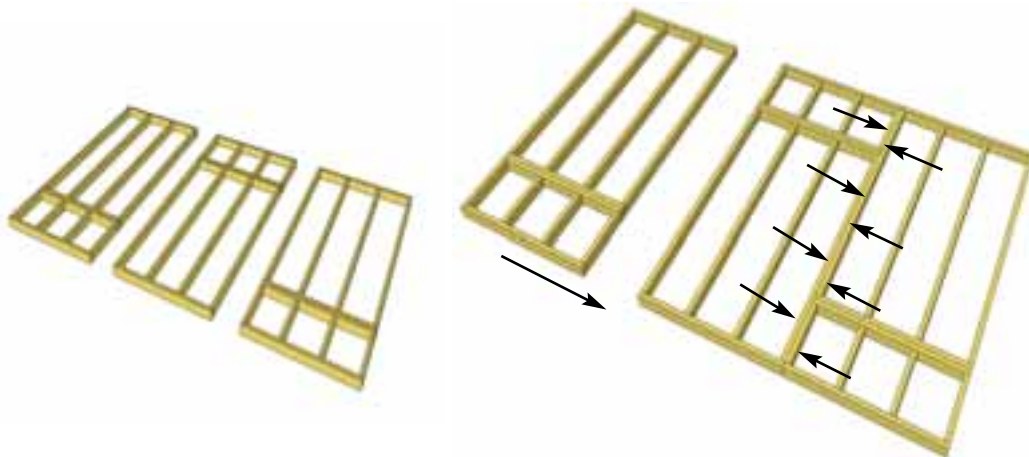

**A5.** Complete all large and small frame attachments. Screw each completed section together with 8 - 2 1/2" Screws.

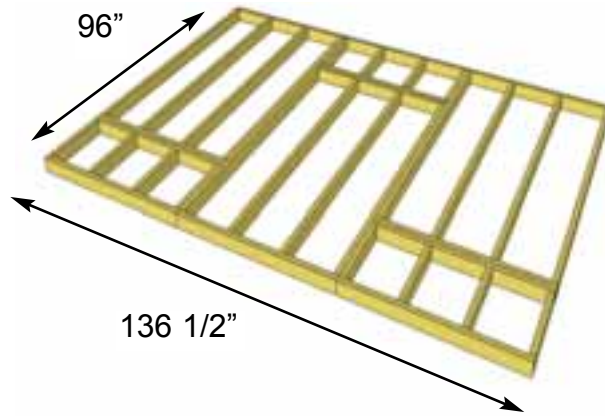

**A6.** When completed, your floor footprint should be 96" wide x 136 1/2" deep.

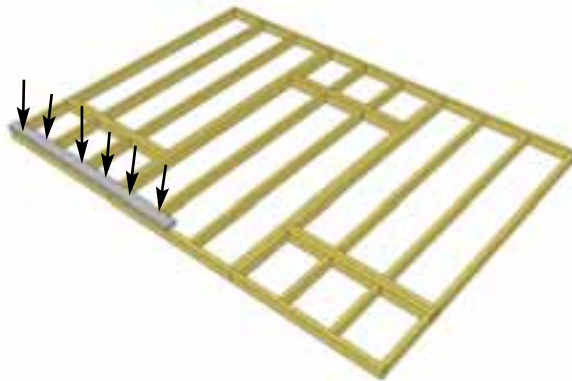

**A7.** Attach **Floor Runners** to completed floor frame. There are 2 floor runners per 136 1/2" side and 5 completed runners in total. Use **6 - 2 1/2" Screws** per Runner.

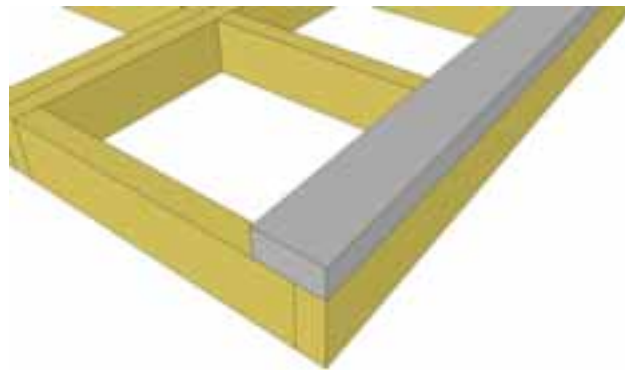

**A8.** Make sure Runners are flush with outside of framing, not overhanging.



**A9.** Complete all Floor Runners.

**Foundations**

**Note:** The floor will be flipped over and floor runners will sit on your foundation. It is important to note that having a level foundation is critical. Choosing a foundation will vary between regions. Typical foundations can be concrete pads or patio stones positioned underneath the floor runners.

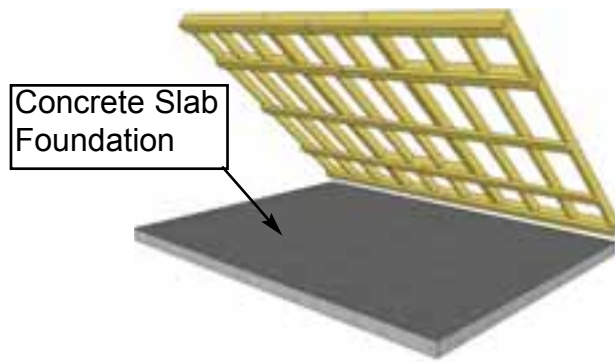

**A10.** With Floor Runners attached, carefully flip the floor over and place on your foundation. **Caution:** you will need 2 people to assist you. Be careful when laying floor down not to bend or twist floor. When in place, level floor completely.

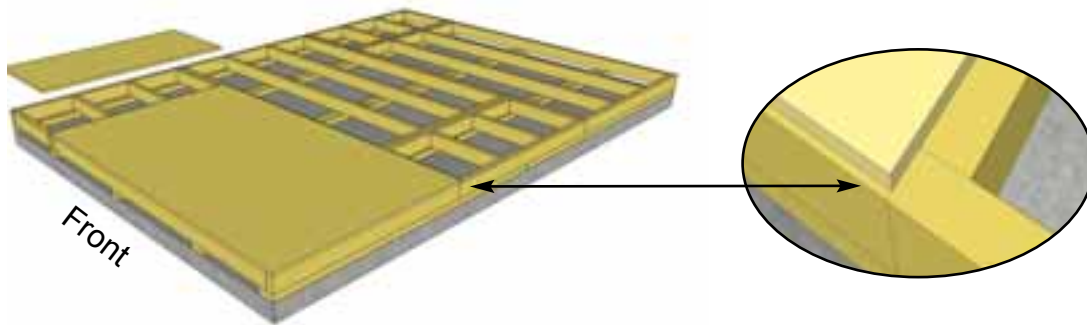

**A11.** Position **Plywood Floor** pieces (6) on top of completed Floor Joists. The Plywood is cut slightly smaller than floor framing and will sit slightly back from outside edge. Keep plywood seams tight.

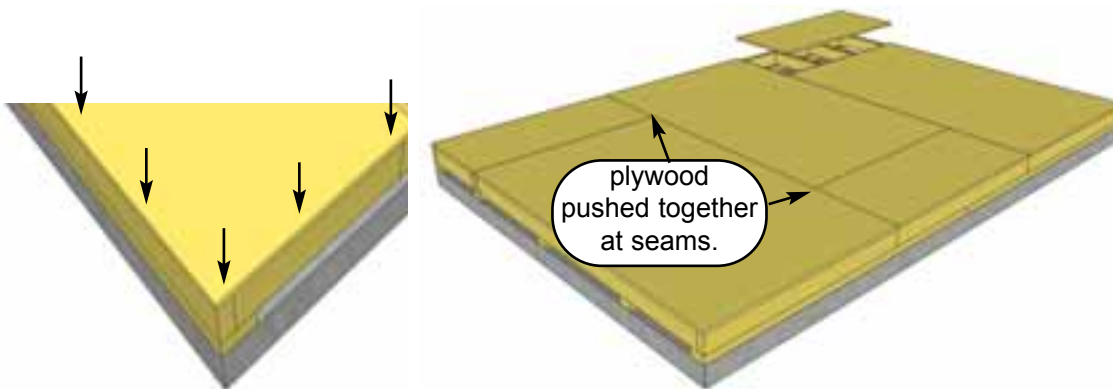

**Hint:** Use a chalk line to mark location of floor joists to determine screw placement.



**A12.** With Plywood positioned correctly on floor framing, attach with 1 1/4" Screws. Use screws every 16".

# B. Wall Section

Exploded view of all parts necessary to complete the Wall Section. Identify all parts prior to starting.

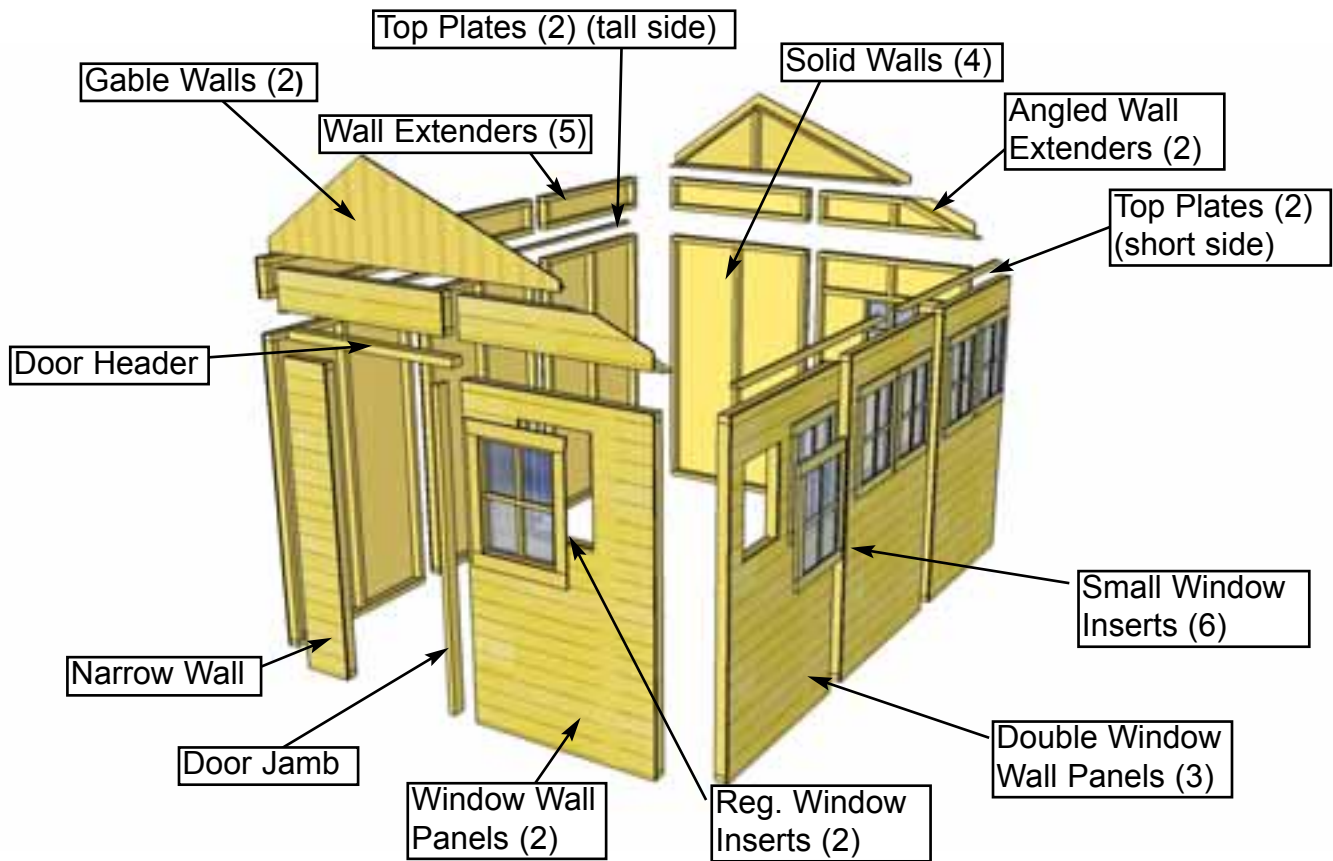

Lay out Panels and Pieces as illustrated below.

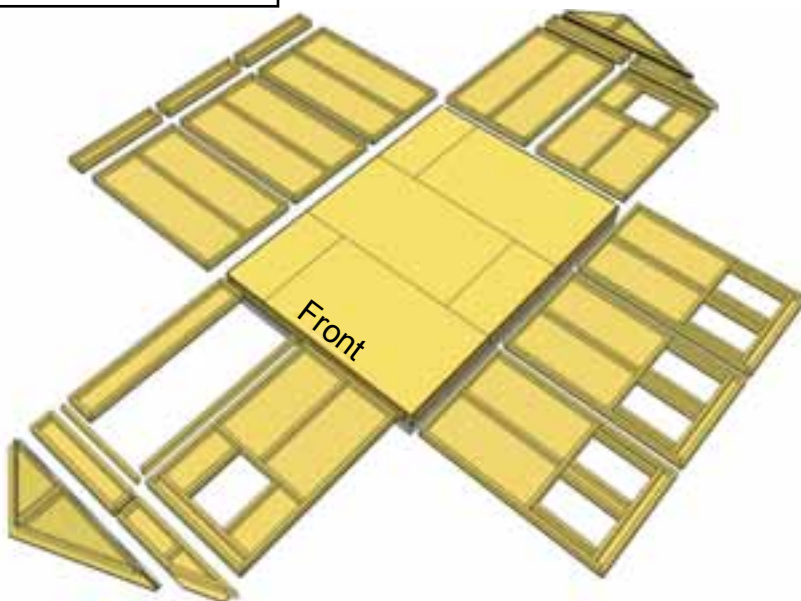

Left Side Polygal Roof Panel Orientation

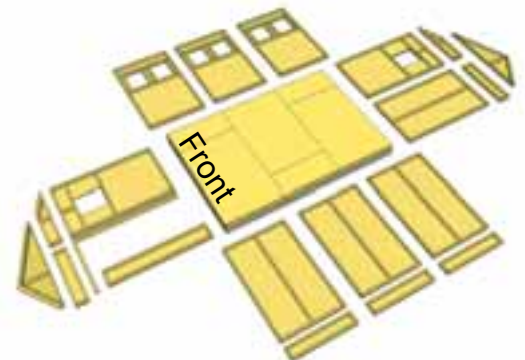

**Important:** If you prefer Polygal Roof Panels on left side when facing front, position wall panels as illustrated above. Follow general assembly directions but note opposite orientations.

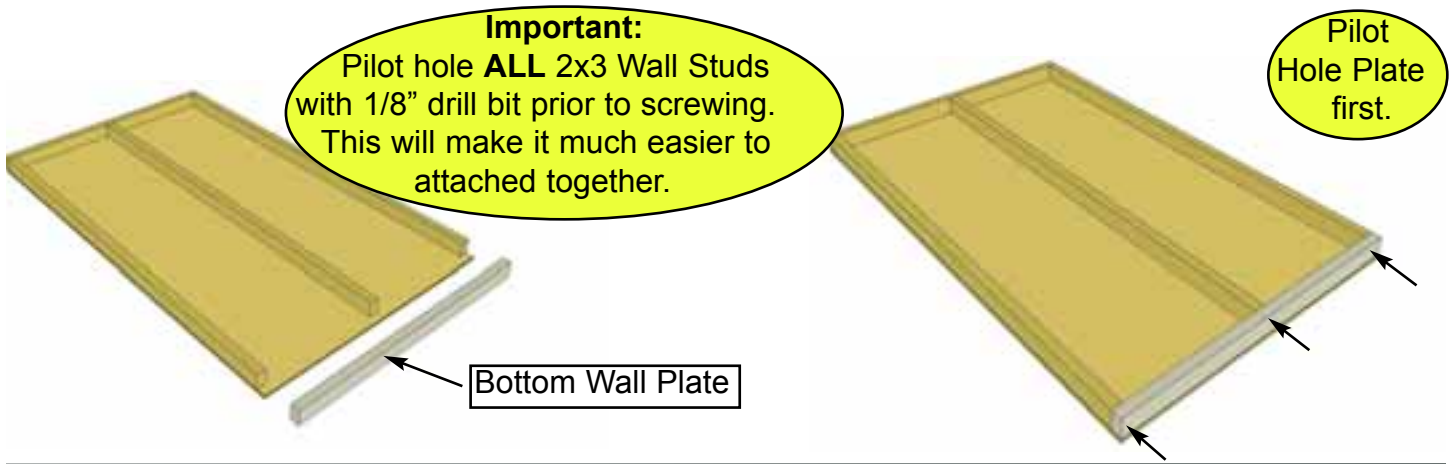

**B1.** Starting with **Solid Wall Panels**, carefully lay panel face down. Position and attach **Wall Plate** (1 1/2" x 2 1/2" x 45 1/2") to bottom of studs of each wall panel with 3 - 2 1/2" Screws. Position so plates are flush with framing.

**B2.** Starting at the Rear Left Side, position a **Solid Wall Panel** on top of plywood floor. The Wall Panel bottom framing will sit flush with floor framing. Wall siding will overhang the floor.

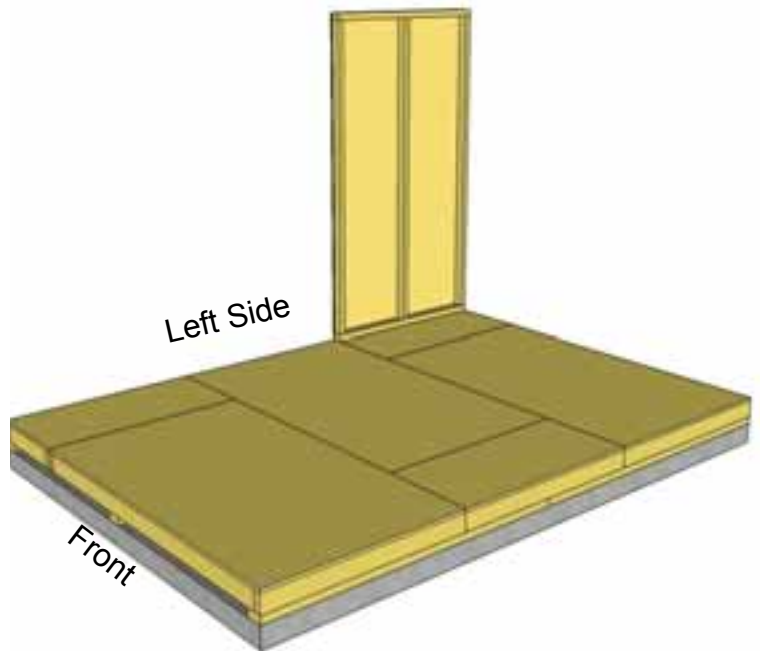

**Important:** Make sure all walls are aligned in their upright position. If not, water may leak into your shed. Unsure if panel is facing up or down? check siding on window wall panel to match alignment, or keep track of your recently attached bottom plates.

**Do Not Attach Walls To Floor until Step B16.**

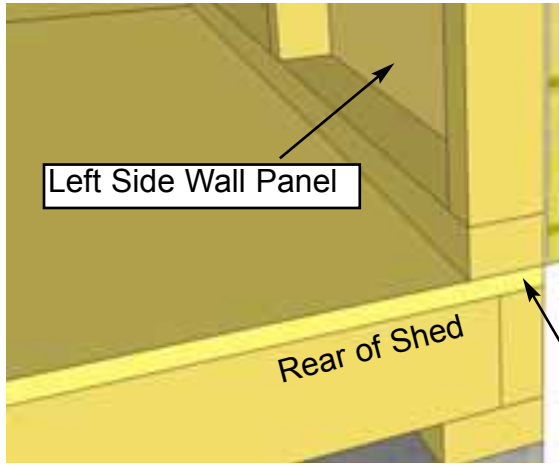

Outside 2x3 framing of wall panel is flush with outside of floor framing when properly aligned.

**B3.** The side panels will sit flush with floor framing in the corners, with the rear panels sandwiched between them. **Note:** Siding will overhang the floor by approx. 1/2".

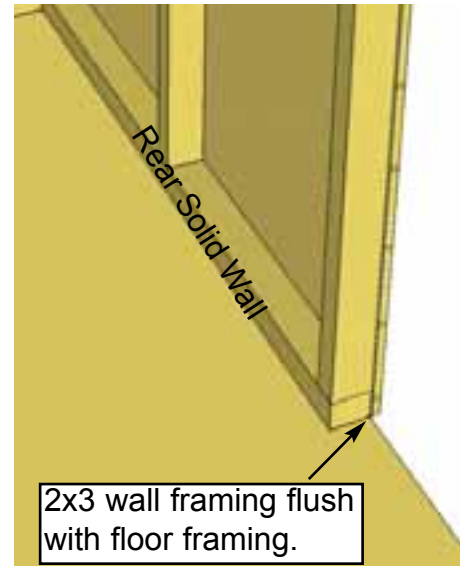
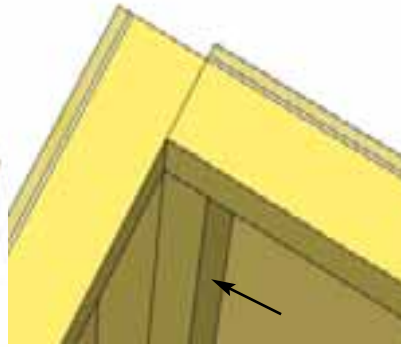

**B4.** Position rear **Solid Wall** on plywood floor. Butt both vertical wall studs of side and rear walls together and attach with **3 - 2 1/2" Screws**. Screw at the bottom, middle and top of stud to secure.

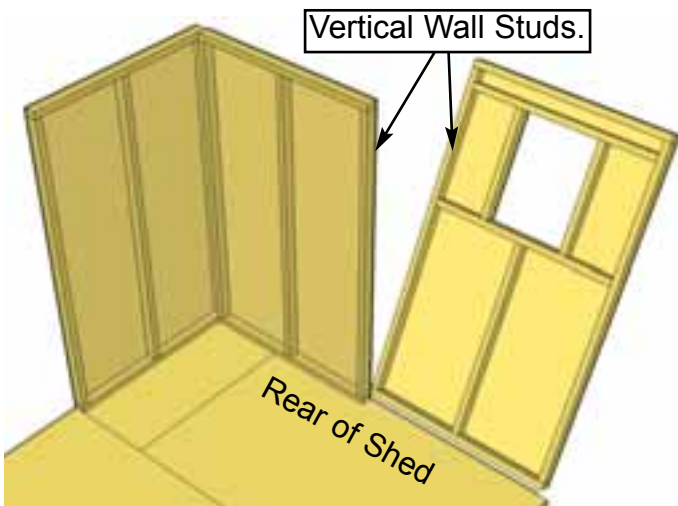

**B5.** With the corner wall attachment complete, position the **Rear Window Wall Panel** so vertical wall studs line up evenly. Use a level to confirm solid and window walls are the same height.

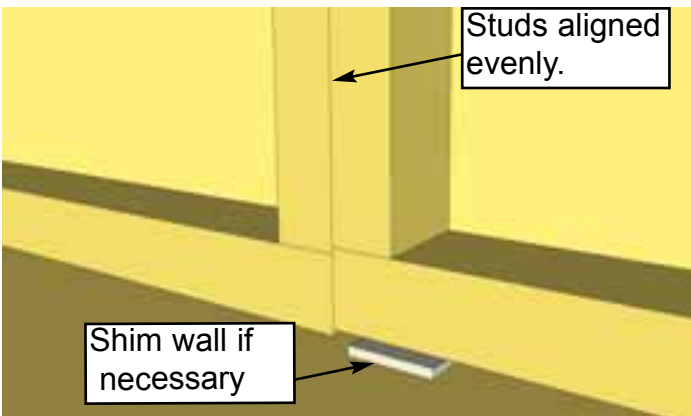

**B6.** With walls positioned correctly, attach Rear Window Wall Panel to Solid Wall Panel as per Step B4.

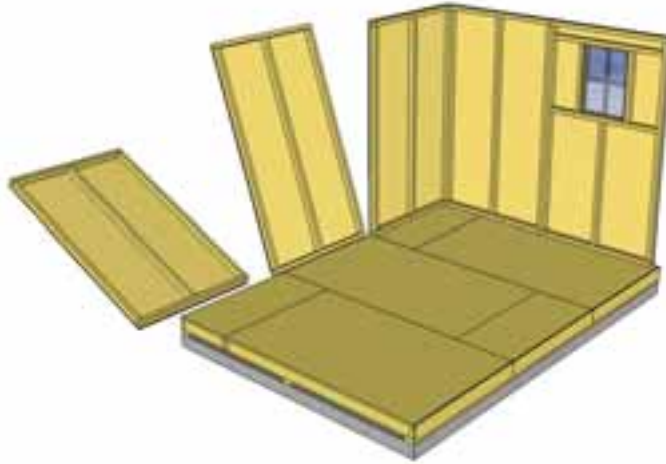

**B7.** Locate 2 Solid Side Walls and position on left side.

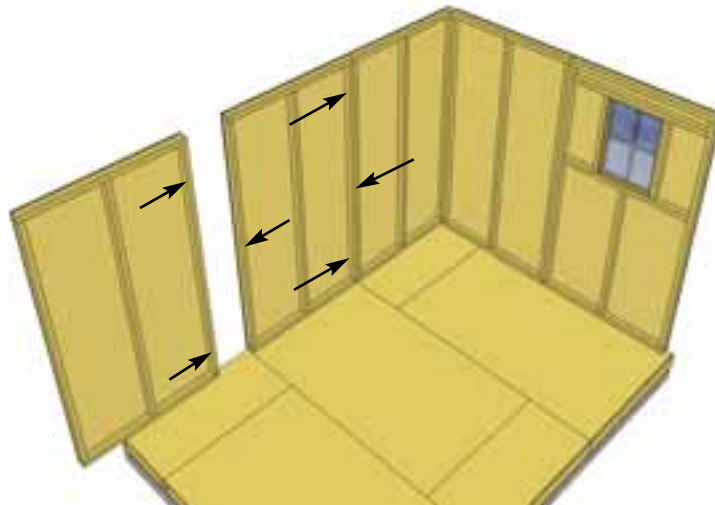

**B8.** Position and secure Wall Panel studs together as per Step B4.

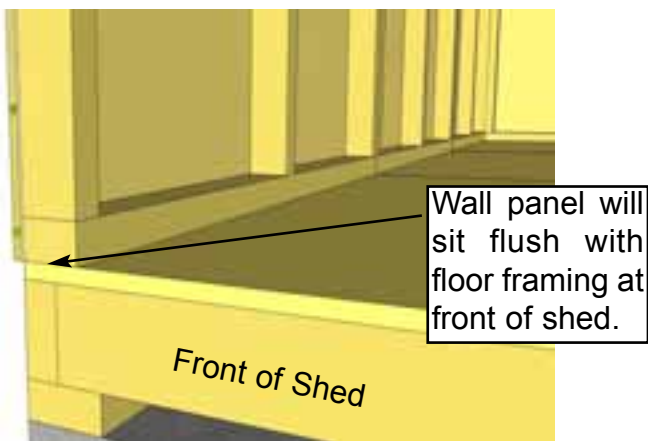

**B9.** Front Side Wall Panel will sit flush with floor framing in corner when positioned correctly. Position Rear Side Double Window Wall on floor.

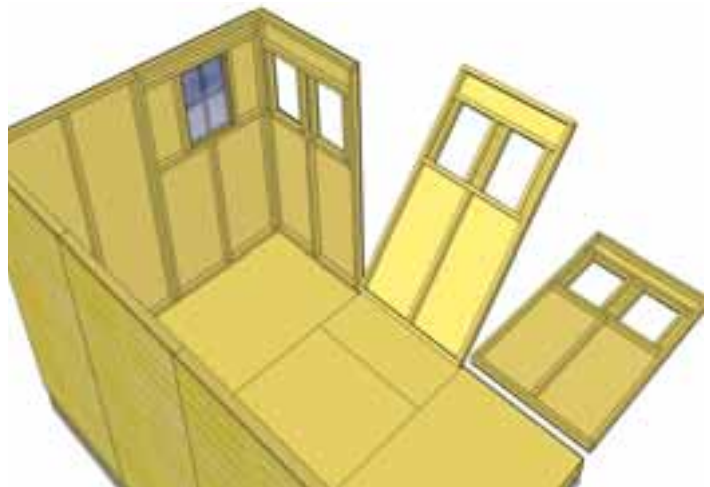
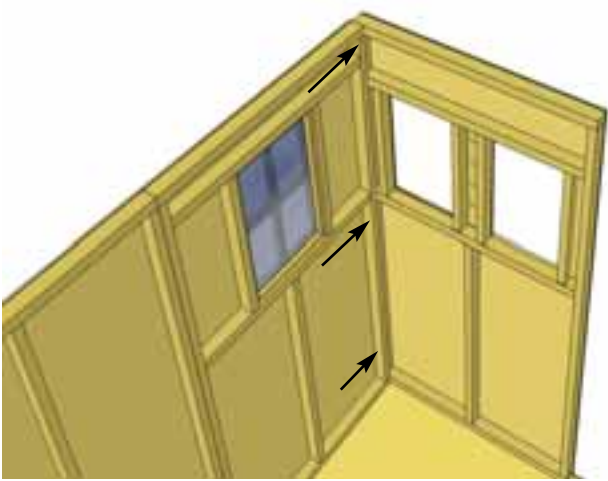

**B10.** Position and secure Wall Panel studs together as per **Step B4**. Locate and position remaining Double Window Walls on floor.

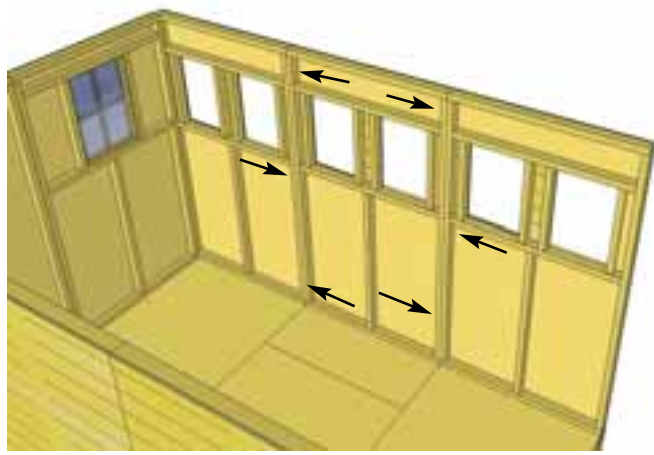

**B11.** Position remaining Double Window Walls and attach as per **Step B4**.



**B12.** Place 2nd Window Wall Panel in front and attach as per **Step B4**.

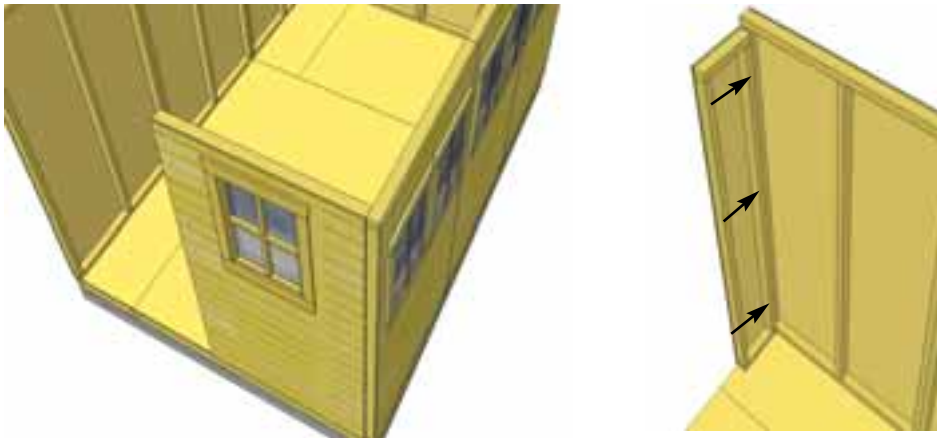

**B13.** Position and attach **Narrow Wall Panel** to left side wall stud with **3 - 2 1/2" Screws** as per **Step B4**. **Note:** Narrow Wall is 73" high (2" shorter than regular walls).

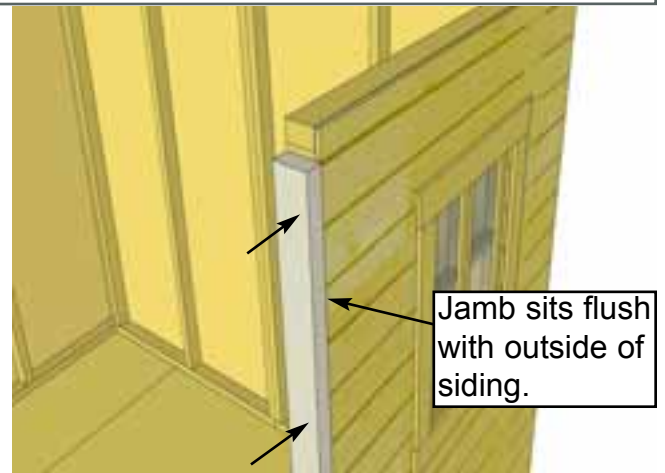

**B14.** Locate **Vertical Door Jamb** and position flush against right wall panel stud. The Jamb is 3" wide and will sit **flush to outside of wall siding**. When positioned correctly, secure Jamb using **4 - 2 1/2" Screws**. **Note:** Part size will vary depending on type of siding chosen for shed. See Parts List.

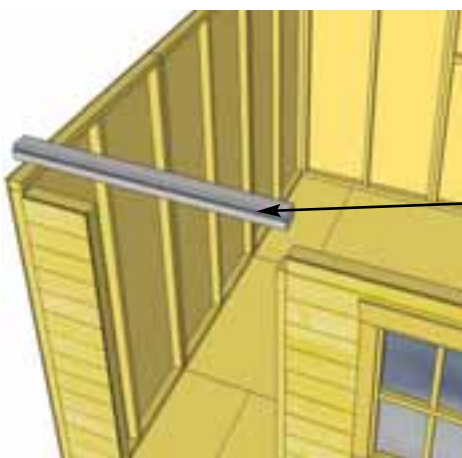

Dado cut on edge

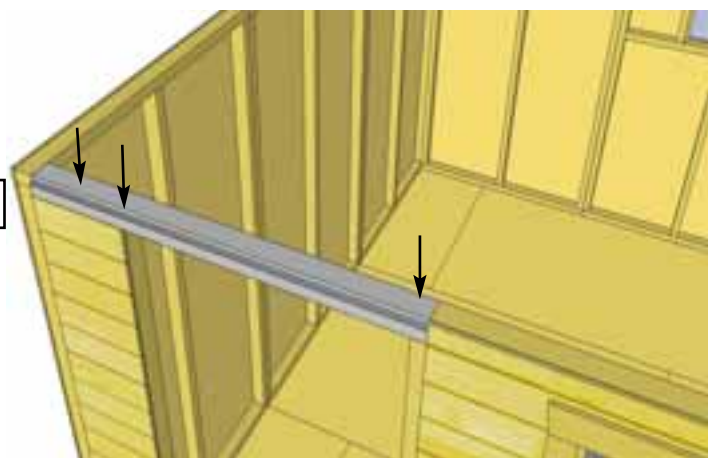

**B15.** Position and attach the **Door Header** to Door Jamb and Narrow Wall Panel top framing. Header should sit flush with Door Jamb and Outside of Narrow Wall Panel Siding. Attach with **3 - 2 1/2" Screws**. **Note:** Part size will vary depending on type of siding chosen for shed. See Parts List.

Confirm 32" wide Door Opening at bottom.

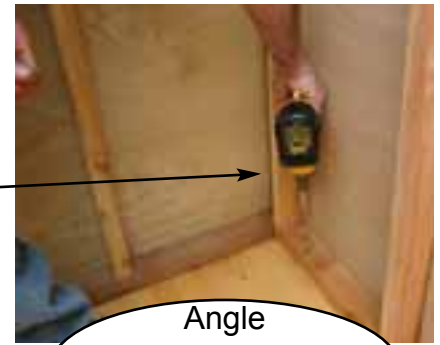
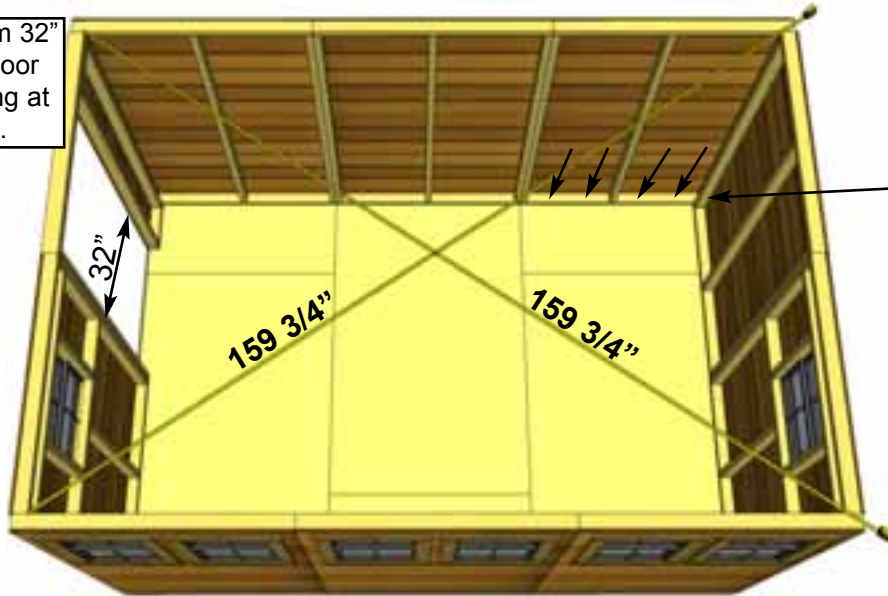

Angle screws into perimeter Floor Joists.

**Advice:** Prior to fastening walls and installing rafters, take time to confirm your walls are level, square and plumb. Measure diagonal at top and bottom of walls corner-to-corner. This should be approximately 159 3/4". More importantly, if measurements are not within 1/4", your walls are not square. Adjusting now will make it easier to the roof section later.

**B16.** When all walls are attached together, check alignment with the floor. Bottom wall framing should sit flush with outside of floor frame. When positioned correctly, fasten bottom wall plates to floor using 4 - 2 1/2" Screws per wall panel. **Important:** If walls are not lining up and appear higher or lower than each other, your floor may not be LEVEL. Please check the level of your floor. You may need to make slight adjustments to level your floor before proceeding.

**Optional:** Caulking seams will help prevent moisture from entering. Caulking is included to complete Polygal Windows only. Additional Caulking may be required.

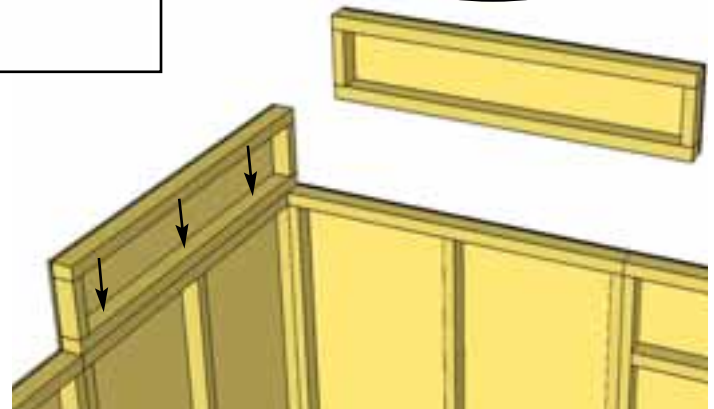
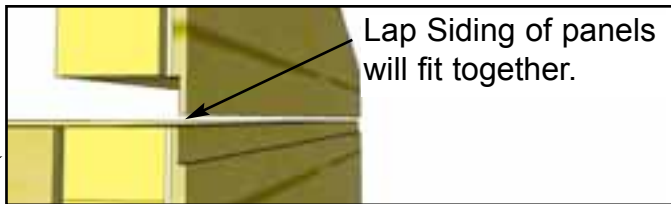

**B17.** Locate and place Side Extender Walls on top of Side Walls in rear corner. Align so 2x3 framing lines up with framing of regular walls. When correctly in place, secure with 3 - 2 1/2" Screws per piece.

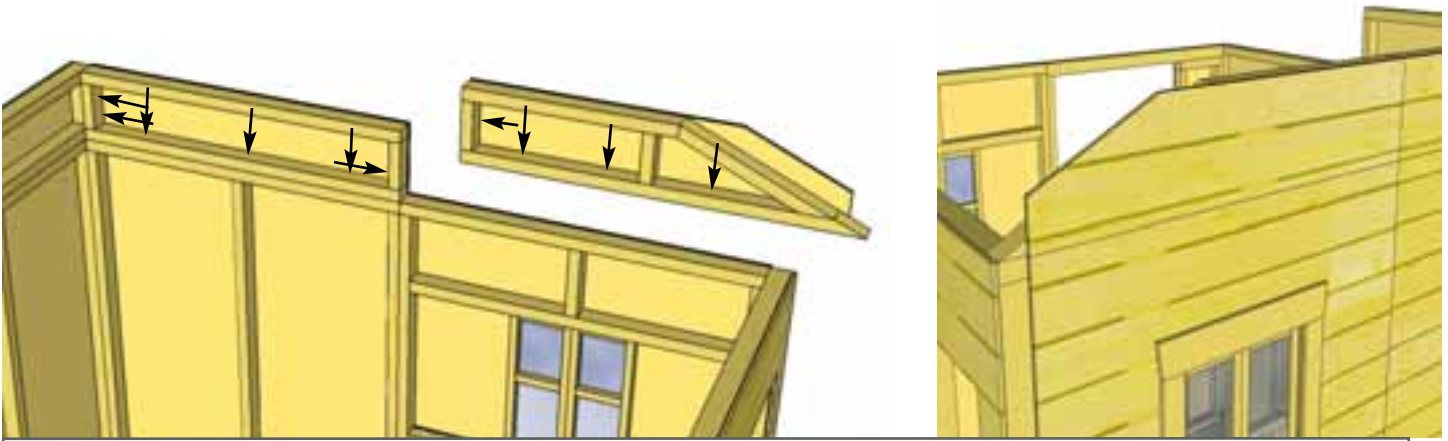

**B18.** Screw vertical framing of corner extenders together with 2 - 2 1/2" Screws. Locate and position an **Angle Extender Wall** on the rear wall of Sun shed. Align once again so 2x3 frame lines up with previously installed Wall Extender and regular wall panel. When correctly in place, secure with 3 - 2 1/2" Screws into Window Wall framing, and 2 - 2 1/2" Screws into adjacent extender.

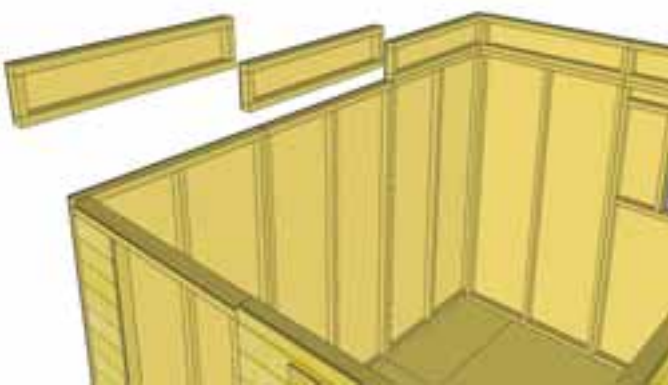

**B19.** Align and attach remaining Wall Extenders as per Step B17 - B18. **Note:** Wall Extenders are not required for the Short Side walls.

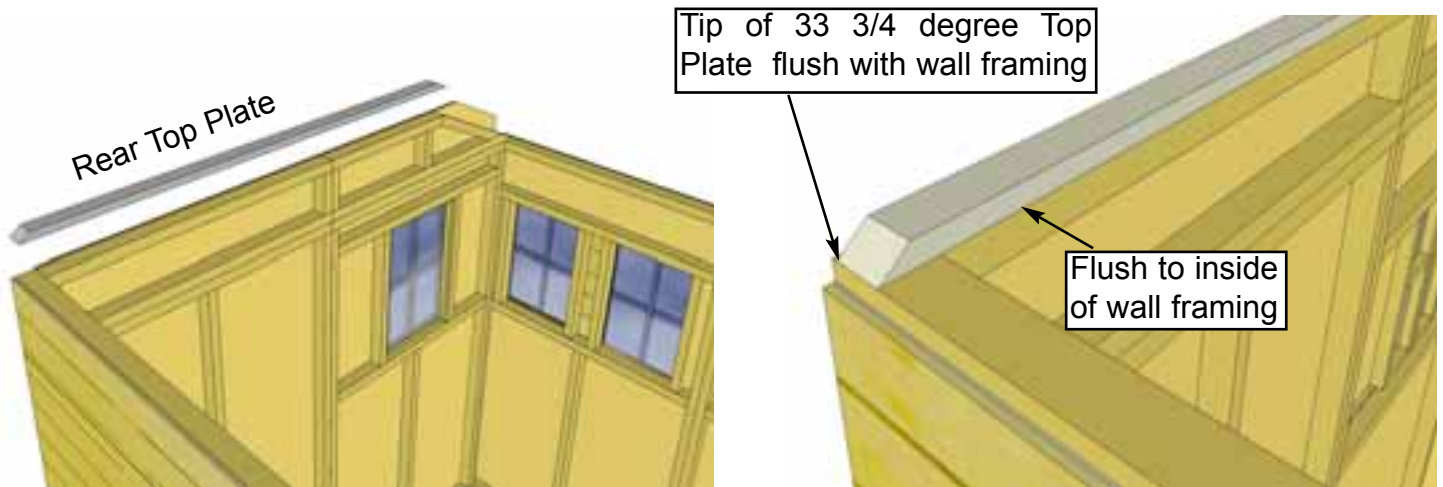

**B20.** Locate **Rear Top Plate** and position on wall framing flush on inside. Align so angle cut on 33 3/4 degree end is facing the high wall and 22 1/2 degree end is facing the short wall.

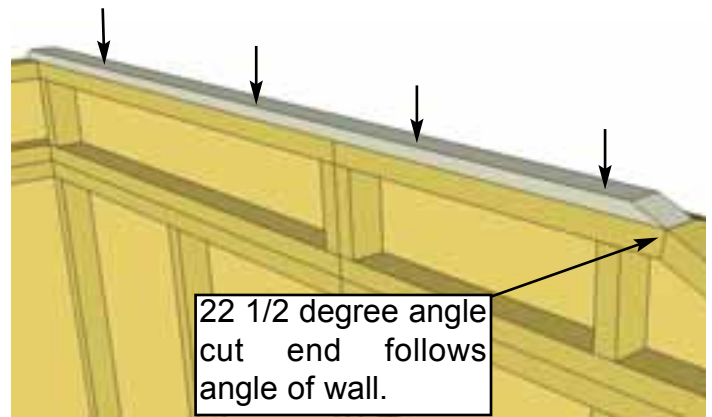
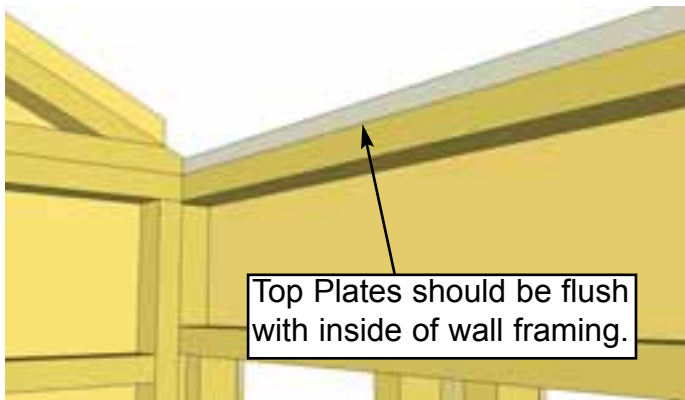

**B21.** When properly positioned, attach by screwing down into top wall framing with 4 - 2" Screws.

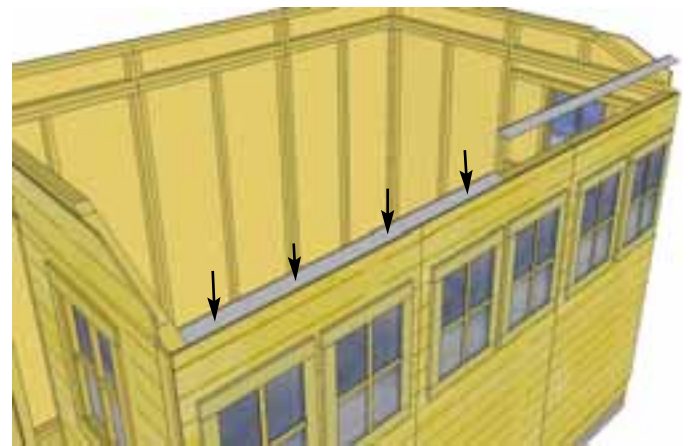
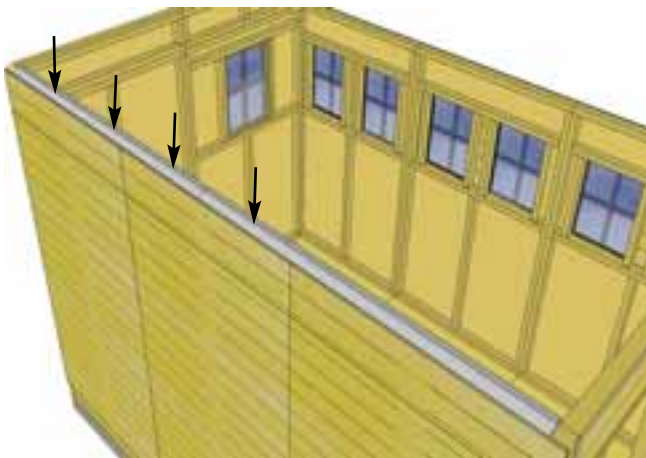

**B22.** Next, attach the Side Top Plates to high wall side. Once again, position top plate so it is flush with inside of wall plate. Side plate should also be flush with Rear Top Plate. Secure with 4 - 2 1/2" Screws per piece. Complete Short Side Top Plates.

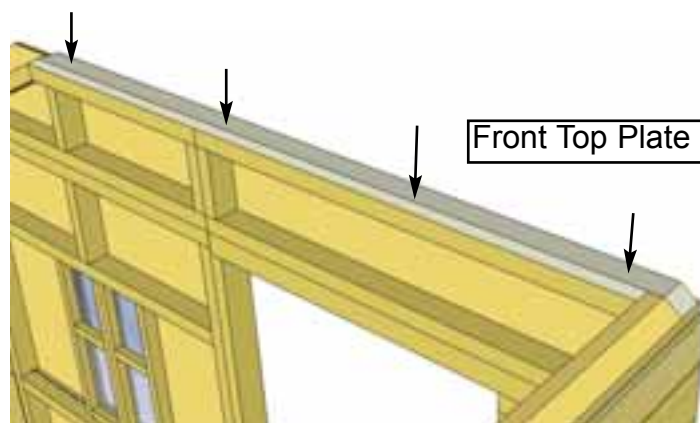

**B23.** Position remaining Front Top Plate on wall framing and secure with 4 - 2" Screws.

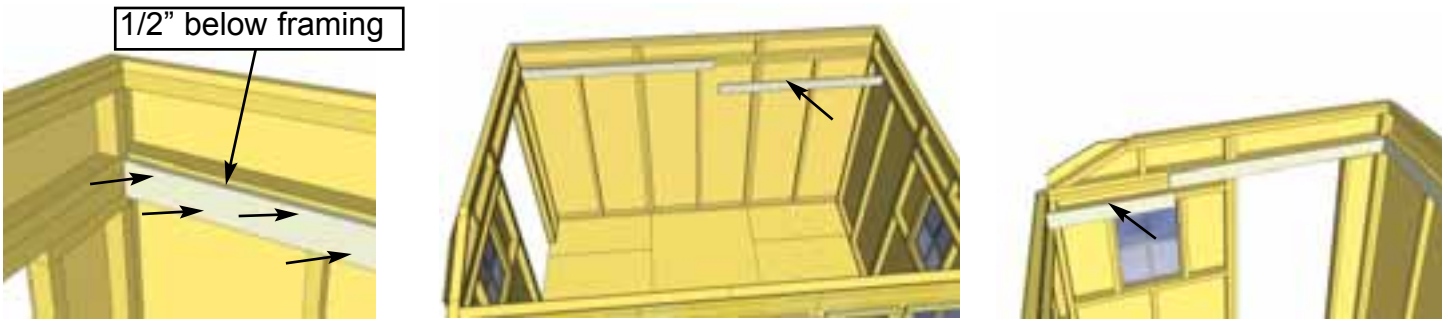

**B24.** Attach **Horizontal Wall Extender Braces** to Framing of Top and Bottom walls 1/2" below extender wall framing. Start with High Wall Side and attach 71 1/2" and 60" long pieces with 10 - 1 1/4" Screws per piece. Alternate screws into both pieces of framing. Complete Front and Rear walls (60" and 30" long pieces) using the same alignment.

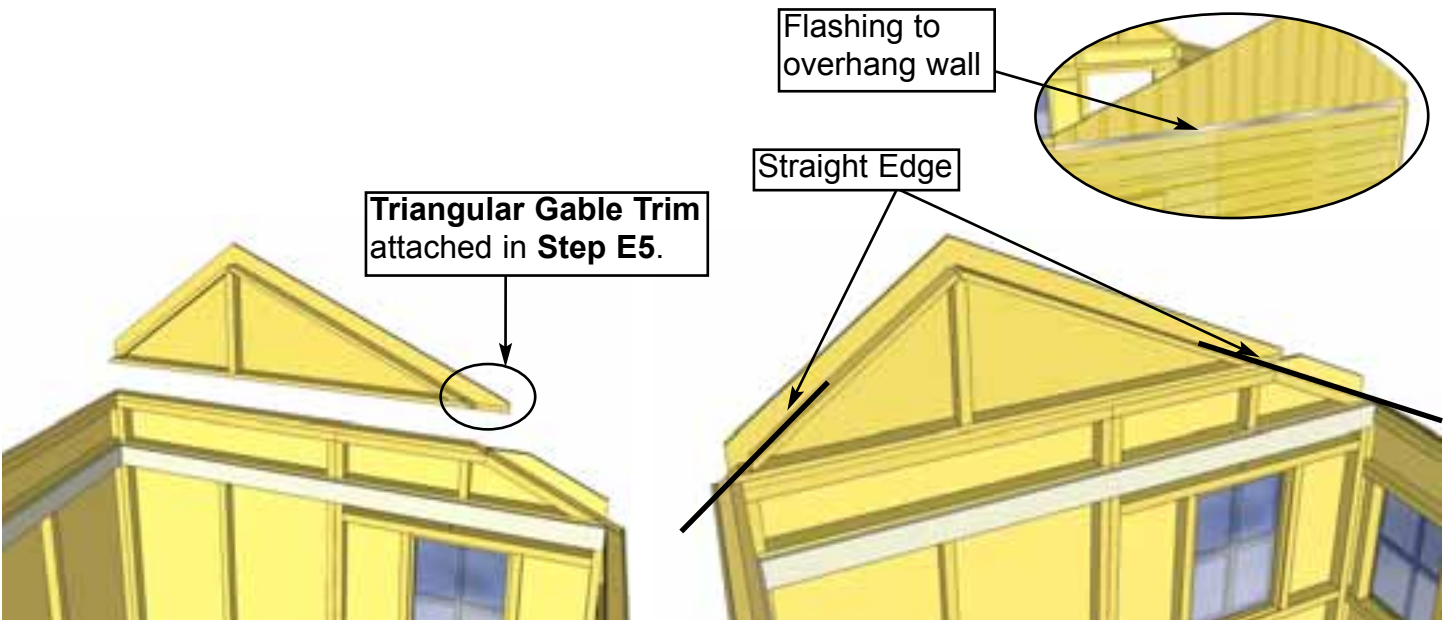

**B25.** Lift up **Gable Wall** and place on top of rear wall. Gable side with 33 3/4" degree cut will be aligned on high wall side. Slide Gable Wall side to side and use a straight edge to line up angled framing of gable with Top Plates and Walls. There is some tolerance, try for best fit on both sides.



**B26.** When Gable wall is positioned correctly, tack in place with 2 - 2" Screws. Adjustment to Gable may be required in **Step C10**, where it will be further secured. Complete other Gable Wall.

# C. Rafter Section

Exploded view of all parts necessary to complete the Rafter Section. Identify all parts prior to starting.

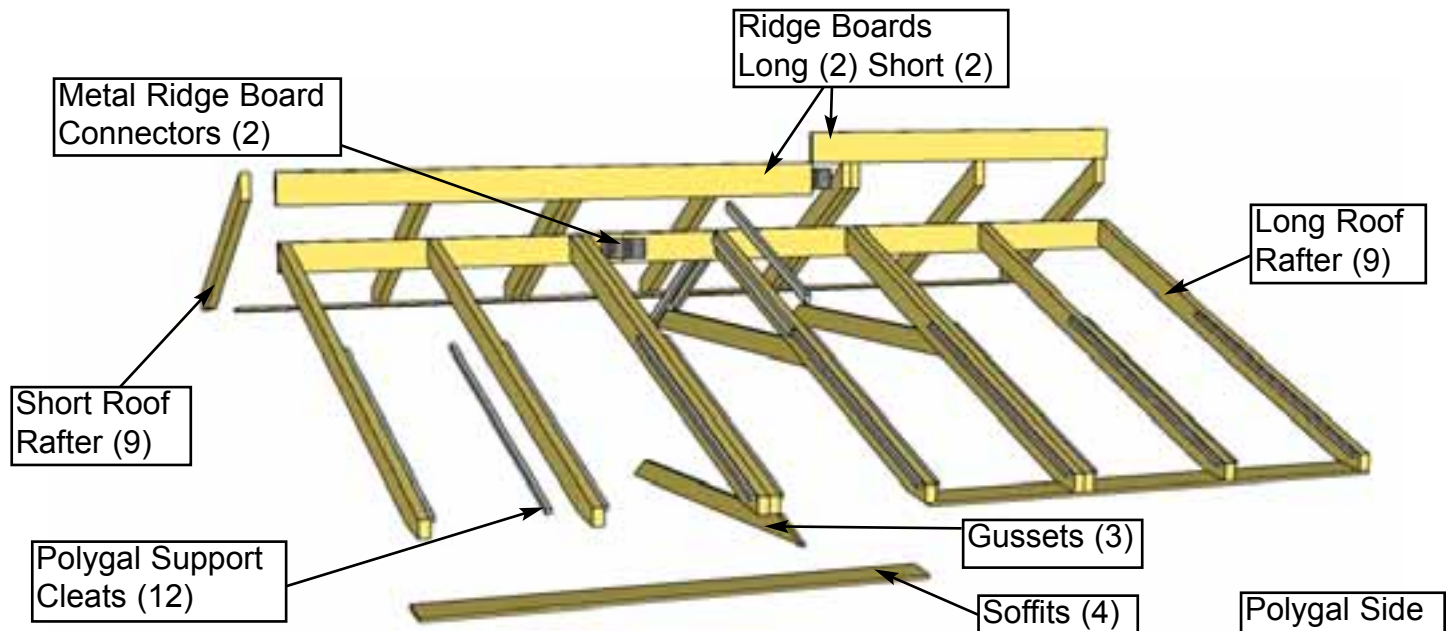

**Important:** Locate all parts necessary to assemble Long and Short Rafter Sections:

**Long Rafter Side:**  
 9 - 77 3/4" long 2x4 Rafters  
 1 - 3/4" x 4 5/8" x 52 1/2" - Ridge Board  
 1 - 3/4" x 4 5/8" x 84" - Ridge Board  
 1 - 1/16" x 3" x 7" - Metal Ridge Board Con.  
 2 - 1/2" x 4 1/2" x 68 1/4" - Soffits  
 12 - 3/4" x 3/4" x 44" - Polygal Support Cleats

**Short Rafter Side:**  
 9 - 37 3/4" long 2x4 Rafters  
 1 - 3/4" x 5 1/8" x 52 1/2" - Ridge Board  
 1 - 3/4" x 5 1/8" x 84" - Ridge Board  
 1 - 3/16" x 2 1/2" x 7" - Metal Ridge Board Con.  
 2 - 1/2" x 3 1/2" x 68 1/4" - Soffits

Follow **Steps C1 - C3** to Assemble Rafter Sections. Make sure to complete on a flat level surface. Please note the differences between the Long and Short Rafters Sides.

**Long Rafter Side**

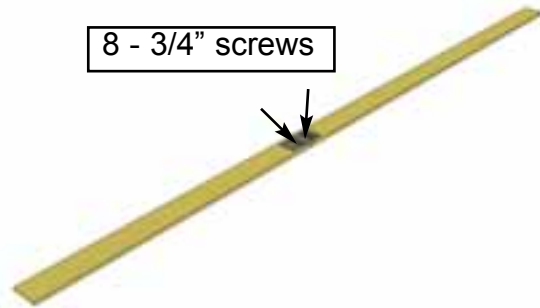
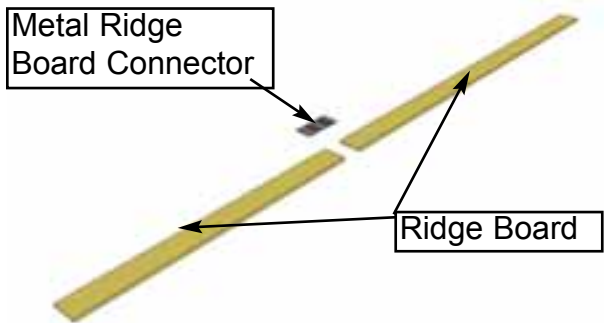

**C1.** Locate both 3/4" x 4 5/8" x 84" & 52 1/2" Ridge Boards (Long Rafter Side) and attach together with Metal Ridge Board Connector using 8 - 3/4" Screws evenly on boards. Total Length when connected is 136 1/2". Complete Short Rafter Side using same procedure only Ridge Boards are 5 1/8" wide.

**C2.** Locate 9 Rafters, 2 Soffits and completed Ridge Board. Lay out on level ground as shown to the right. Double up Rafters as illustrated. Screw doubled up Rafters together with 3 - 2 1/2" Screws per piece. **Note:** completed rafter section will be flipped over in Step C4.

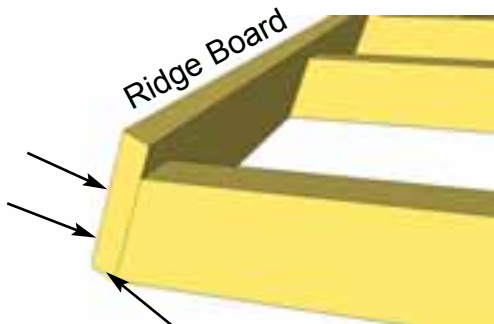
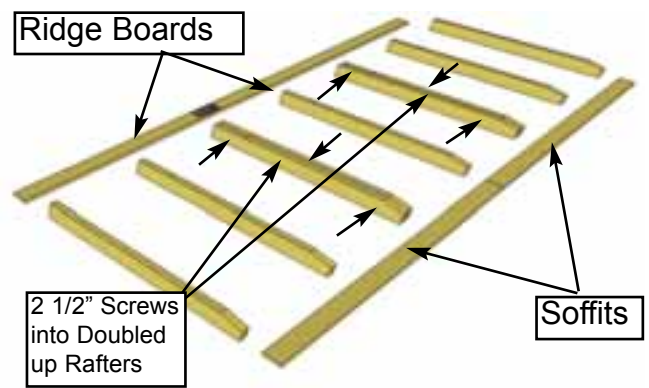

**C3.** Attach completed Ridge Board to ends of both outside rafters with 2 - 2" Screws per end. Measure and position interior Rafters as illustrated below. When positioned correctly, attach Ridge Board to remaining rafters with 2 - 2" Screws / rafter end.

**Important:** Pilot Hole Ridge Board and Soffit to prevent splitting!

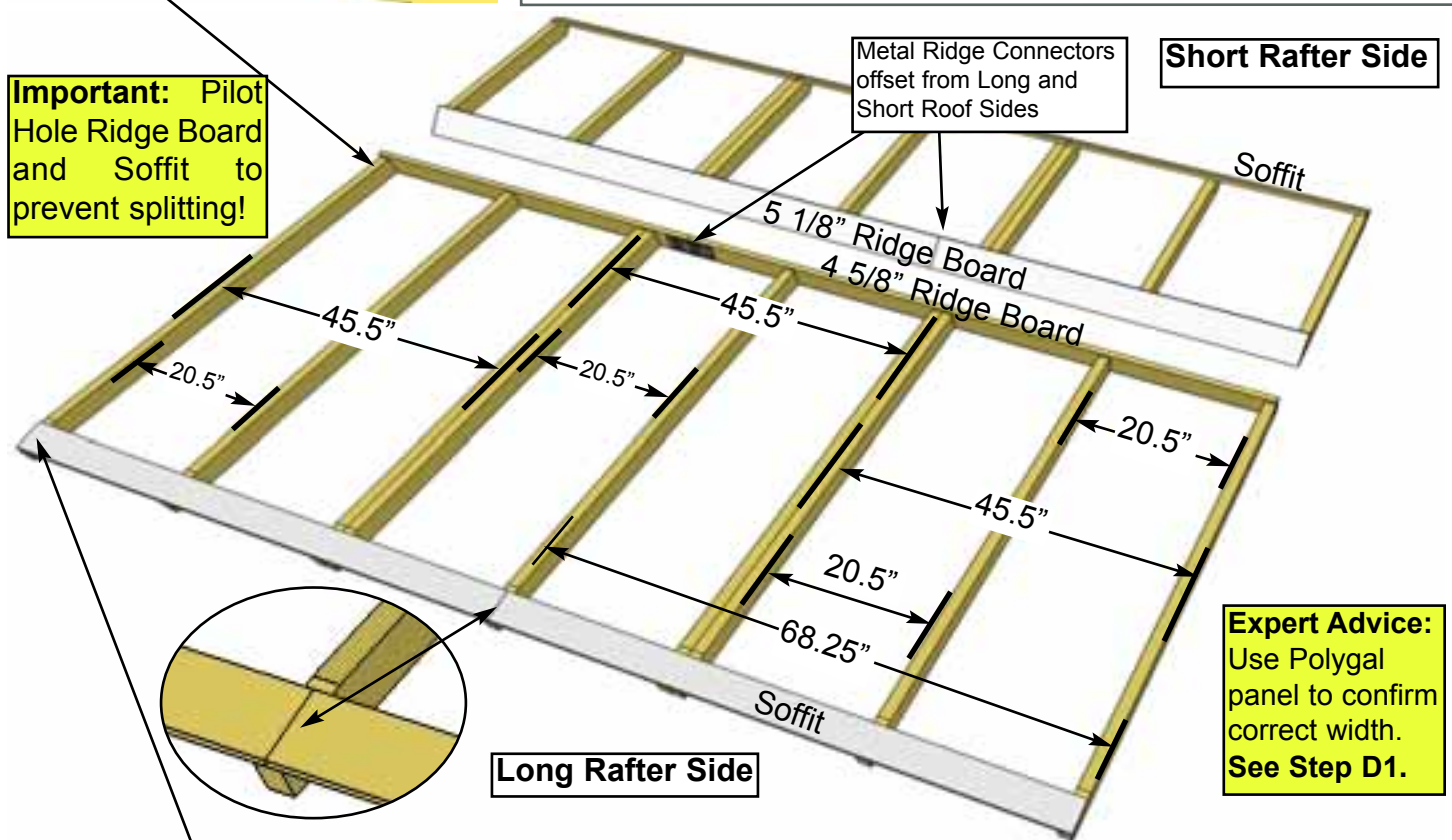

**Expert Advice:** Use Polygal panel to confirm correct width. See Step D1.

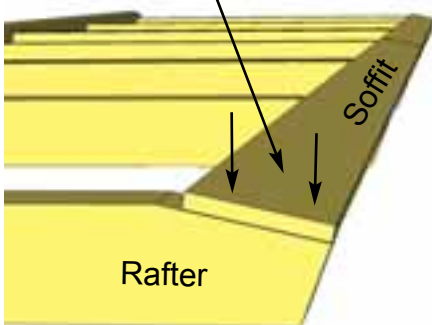

**C4.** Attach end of a 68 1/4" long Soffit Board flush to ends of outside rafters with 2 - 1 1/4" Screws per rafter end. **Drill pilot hole in Soffit ends to prevent splitting.** Complete both outside rafter / Soffit connections first. Measure and position interior Rafters as illustrated above. When positioned correctly, attach Soffits to remaining rafters with 2 - 1 1/4" Screws /rafter. Flip completed rafter section over. Complete Short Rafter Side as per Steps C2 - C4 with the following exception: **When attaching Ridge Board to Rafter ends, make sure Metal Ridge Board Connector is positioned so offset to first Rafter Section. See Step C9 for illustration.**



Slide Bottom of Ridge Board into notch of gable.

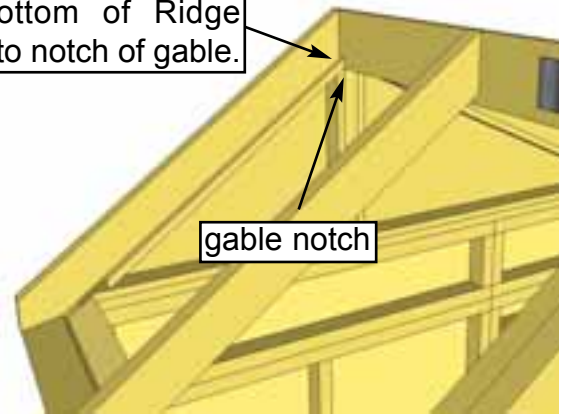

gable notch

**C5.** Starting with the Short Rafter Side, lift and flip completed section over so Soffit is facing down. Slide rafter up on gable framing until bottom of Ridge Board slips into gable notch. Position rafters so they sit evenly on Gable framing from side to side.

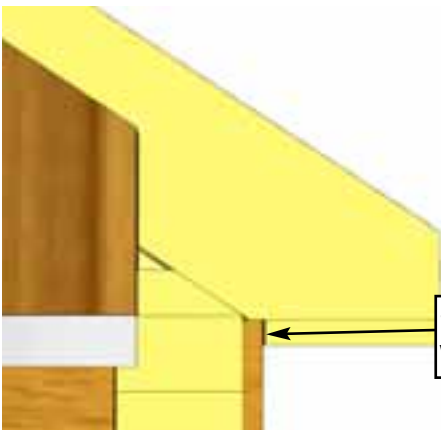

**Important:** make sure Metal Ridge Board Connectors on Long Roof Side and Short Roof side are offset. **See Step C9.**

Slight gap between wall and soffit.



**C6.** Where Wall and Soffit meet, a small gap may appear. Confirm all Rafters are resting on Top Plate.

**C7.** Lift and flip Long Rafter Side up and place on Gable framing. Make sure Metal Ridge Board Connectors of both Roof Sections are offset. See Step C9.

Bottom of Ridge Board fits in gable notch. Top of Ridge Board will sit 1/2" lower than short rafter side ridge board.

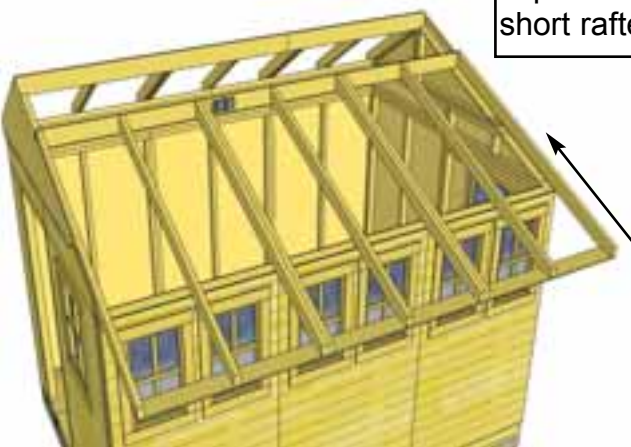

**C8.** Slide Long Rafter Side on Gable framing so bottom of ridge board slips into Gable notch. Soffit will sit approximately 1/8" away from wall as per Step C6.

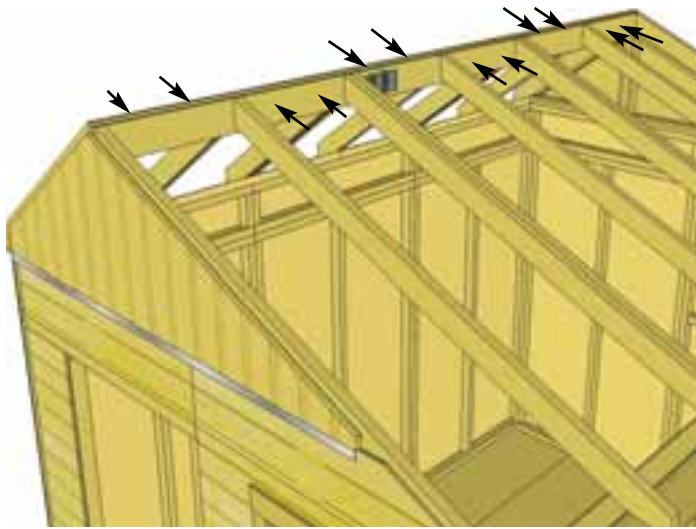

Offsetting Metal Ridge Board Connectors.

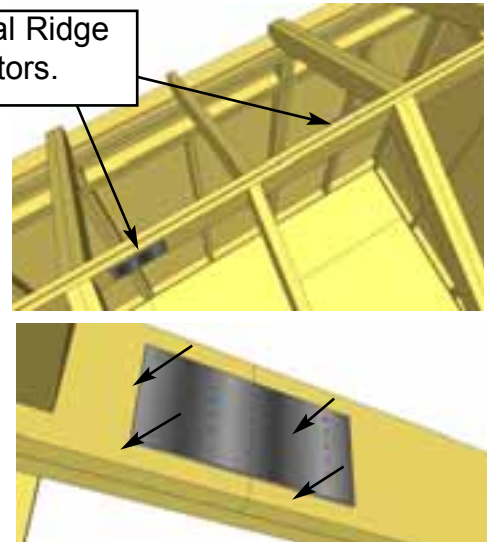

**C9.** Where Ridge Boards meet, press together and secure with 12 - 1 1/4" Screws. In addition, place 4 - 1 1/4" Screws into any of the remaining Metal Ridge Board Connectors holes. Complete both sides.

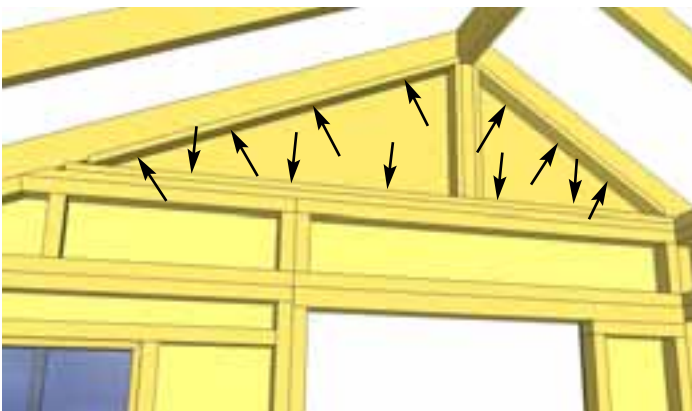

**Important:** If Gable framing does not line up with Rafters, remove temporary 2" screws from gable framing (B26), re-align gable and proceed to Step C10.

**C10.** When aligned, secure Gable framing to rafters with 7 - 2" Screws. Further secure to top plate with an additional 5 - 2" Screws (7 in total). Secure other Gable.



**C11.** Prior to securing the Long Rafter Side, make sure walls are aligned correctly. Have two helpers push on both side walls at the top from the outside until side top plates are 91" apart from the inside.

Rafter Brackets are bent to 22° and 33°. Use correct bracket for each side.



Leave a 1" gap from top of rafter

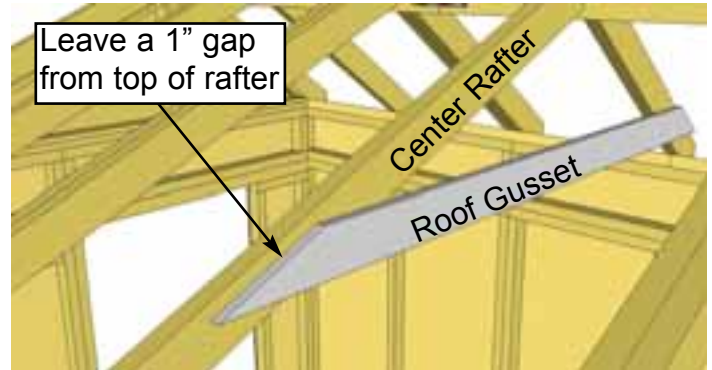

**C12.** Attach all **Single** and **Double Rafter Brackets** where rafters meet Top Wall Plates inside of shed. Attach with **2 - 1 1/4" Screws** and **2 - 2" Screws** per Single Rafter Bracket and **6 - 2" Screws** per Double Rafter Bracket. Position a Roof Gusset on the Center Rafter. Leave a 1" gap from the top side of the rafter.

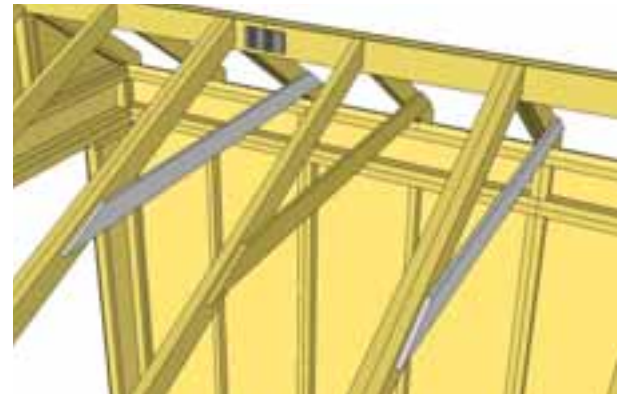

**C13.** With Gusset correctly positioned, attach to Rafter with **4 - 2" Screws** per side. Use a level to check for square. Pilot hole end of Gussets to prevent splitting. Complete installation of remaining Gussets.

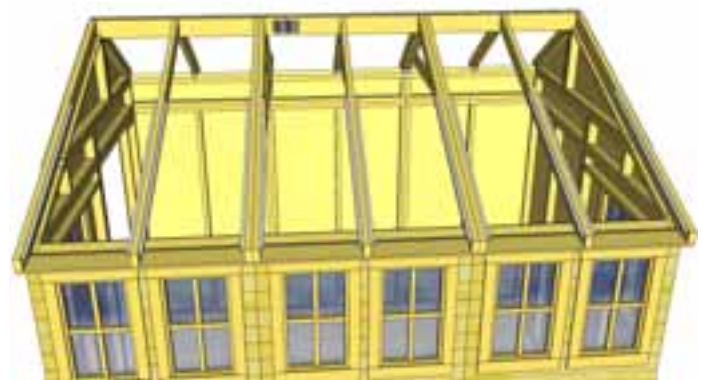
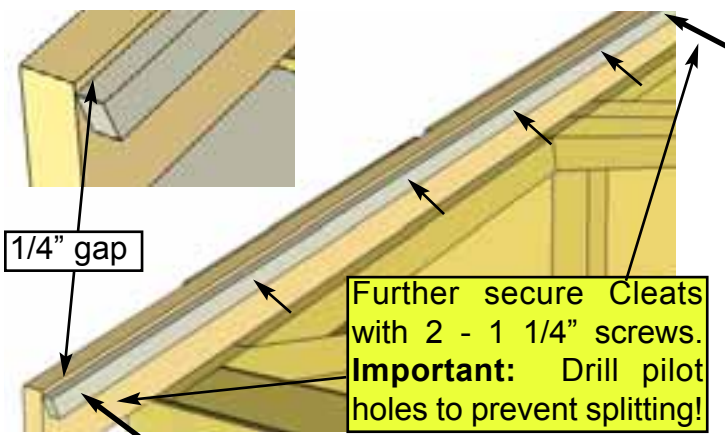

**C14.** Position **Polygal Support Cleats** on each Long Rafter flush to end and recessed 1/4" down from top of rafter. Pilot hole 1/8" in both ends and attach with **1 1/4" Screws**. Nail also to rafter using **4 - 1 1/2" Finishing Nails**. **Note:** Start nails in Supports on ground first. Complete remaining 11 Polygal Support Cleats.

# D. Roof Section - Cedar

Exploded view of all parts necessary to complete the Roof Section. Identify all parts prior to starting.

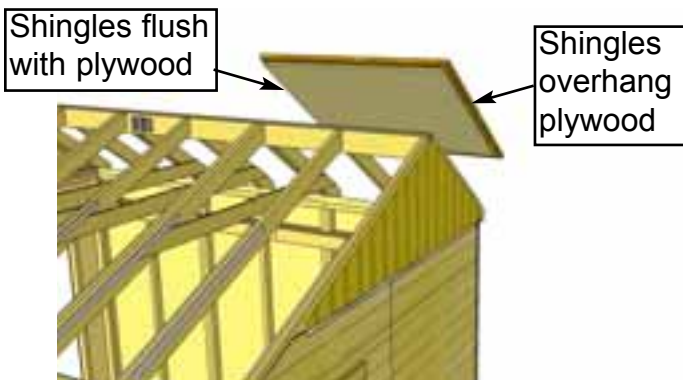
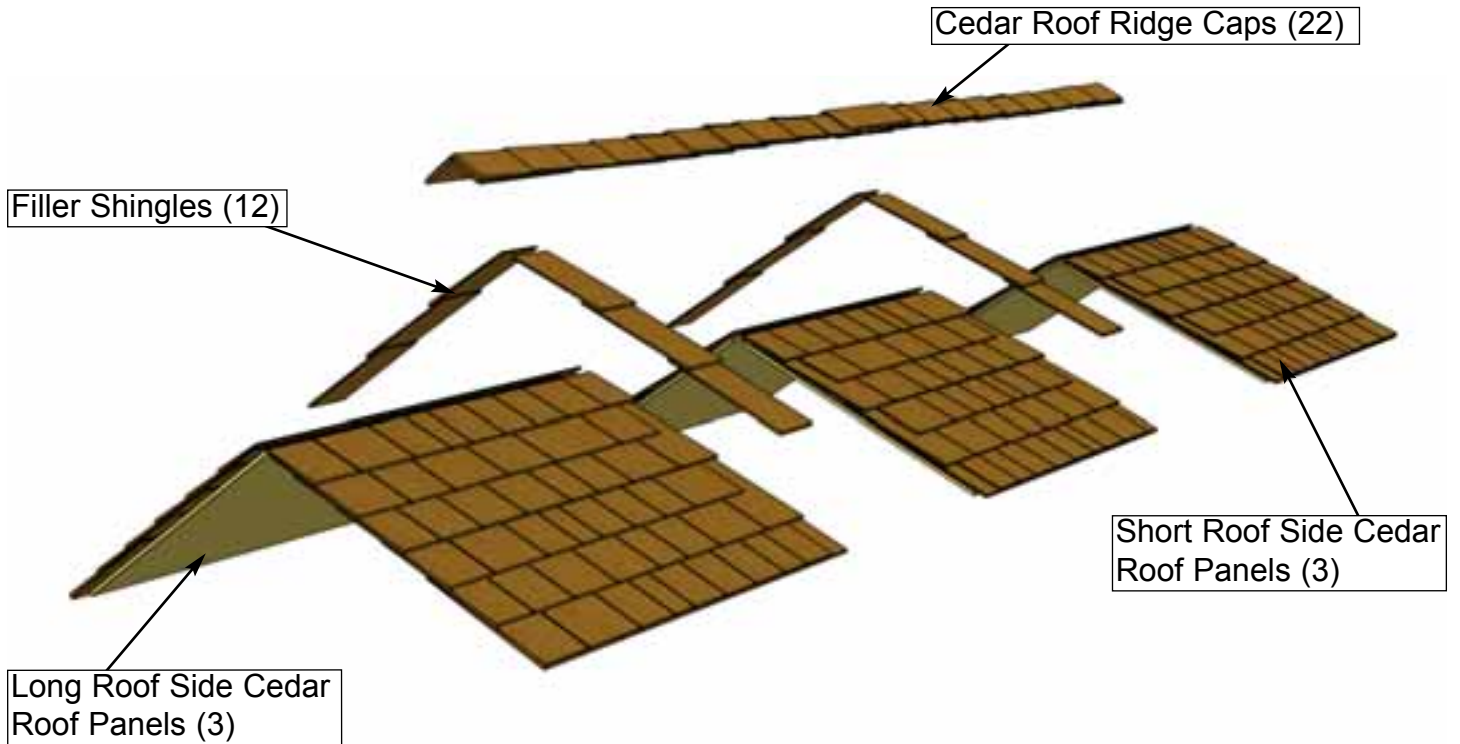

**D1.** Identify all **Roof Panels**. There are 2 Outside Right, 2 Center and 2 Outside Left Roof Panels. The outside of the panels will have shingles overhanging the plywood. Starting with an Outside Roof Panel on Short Rafter Side, lift up and place on rafters so centered on mid rafter. Plywood on roof should be flush with end of rafter at bottom.

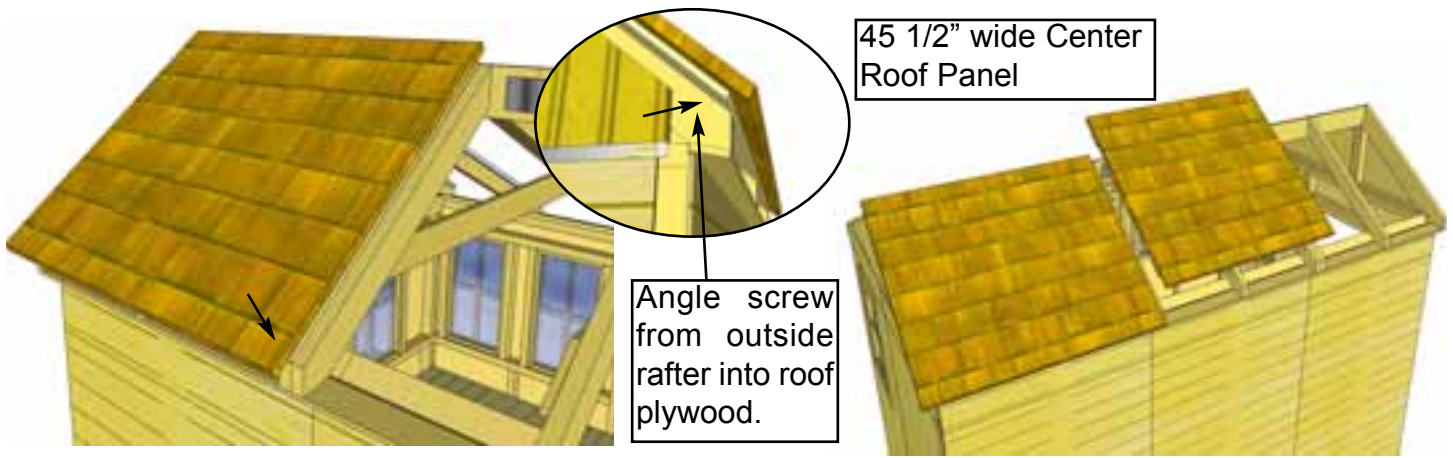

**D2.** Place Roof Panel so it sits flush on 3rd rafter from the outside (doubled up rafter). Plywood on roof should be flush with end of rafter at bottom. From the outside, screw down through bottom row of shingles into rafter with 1 - 2 1/2" Screw. Additionally, angle a 2 1/2" Screw from outside rafter into roof plywood. Position Center Roof Panel on both doubled up rafters.



**D3.** Position Center Roof Panel with plywood flush with bottom end of rafter as per Step D1 & D2. From side to side, make sure Roof Panel is sitting equally on rafters. When positioned correctly, screw down through bottom row of shingles into rafter with 2 - 2 1/2" Screws.



**D4.** Lift up and place an Outside Roof Panel on rafters. Again, plywood on roof should be flush with end of rafter at bottom.

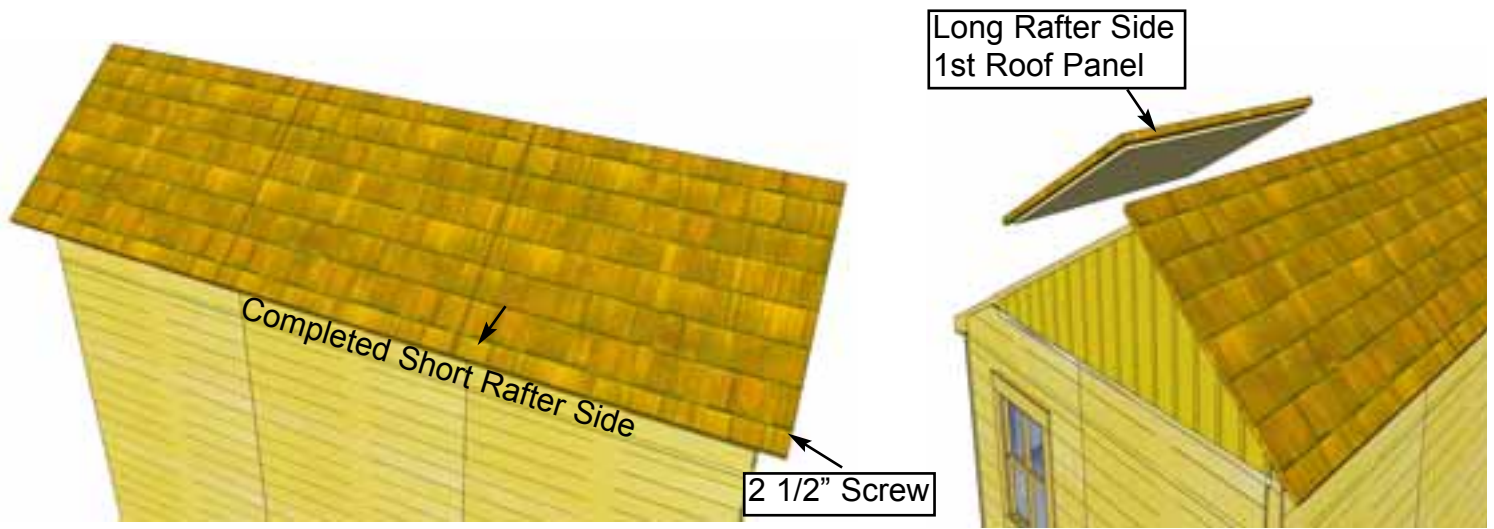

**D5.** When positioned correctly on rafters, secure as per **Step D2**. Lift and Place 1st Outside Roof Panel for Long Rafter Side.

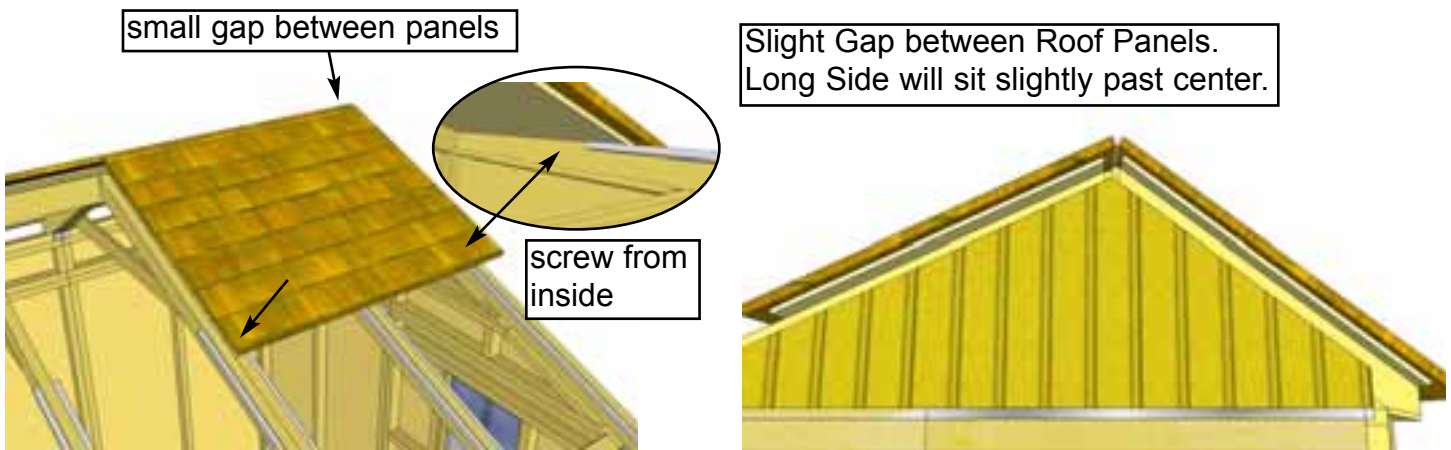

**D6.** Position Outside Roof Panel equally on rafters. Align Roof Panels at top so only a small gap between panels exists. When positioned correctly, screw down with 1 - 2 1/2" Screw in bottom row of shingles. Additionally, from inside, angle a 2 1/2" Screw from the roof rafter into the roof plywood to secure.

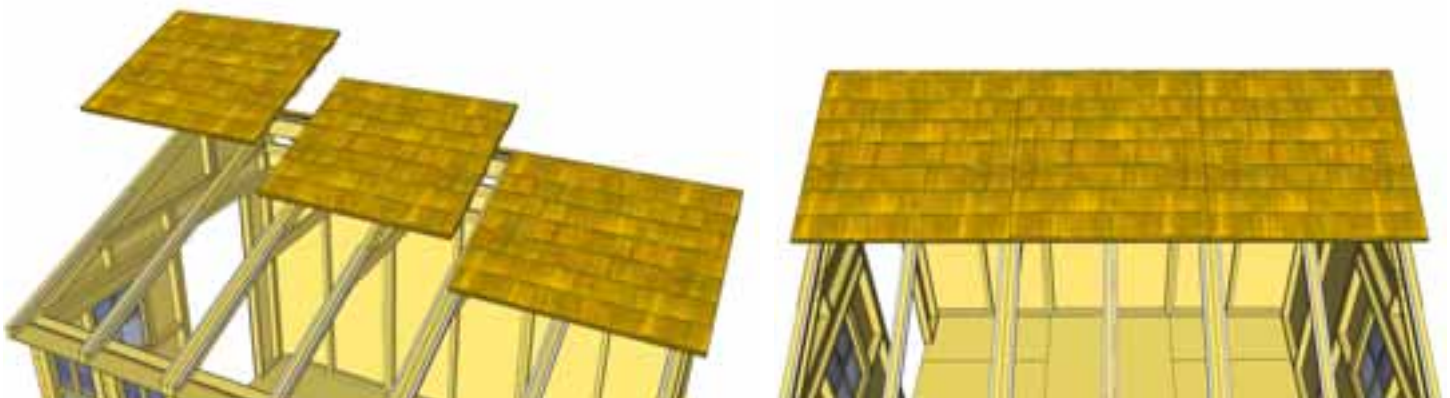

**D7.** Follow **Steps D1 - D6** for positioning and attaching Long Rafter Roof Panels. Work from inside the Sunshed when completing the Roof Panels.



**D8.** Next, install **Filler Shingles** to hide roof seams of shed. Starting at bottom on Short Roof Side, push a Long Filler Shingle underneath shingles directly above it until end is flush with bottom shingles.



**D9.** Screw first filler shingle down to rafters above the exposure line, using 1 - 2 1/2" Screw per panel (2 in total). Make sure to screw into both rafters.



**D10.** Slide in the next Long Filler shingle and attach as per **Step D9**. At the top, use smaller shingles to fit. Attach final shingle to roof with 2 - **Shingle Nails**. Complete Long Roof Side next. There are 2 - Long shingles and 1 Short shingle per roof seam.

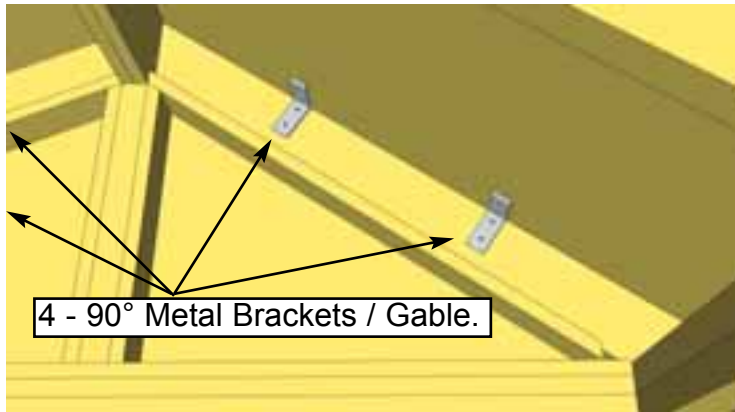

**D11.** Position **90° Metal Brackets** on plywood and outside rafters and secure with **4 - 1 1/4" Screws**. There are 4 brackets per gable.

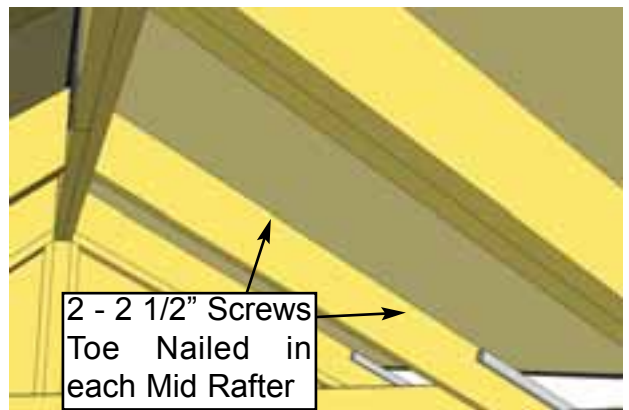
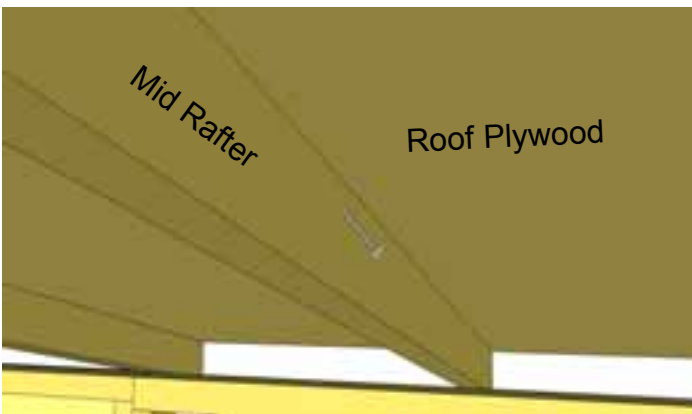

**D12.** To further secure roof panels, from the inside, drill pilot holes in each Mid Rafter (2 per Rafter) on an angle. Using **2 - 2 1/2" Screws**, secure rafters to roof plywood. **Note:** from outside, have a helper push roof panel down so plywood sits flush against rafter when securing.

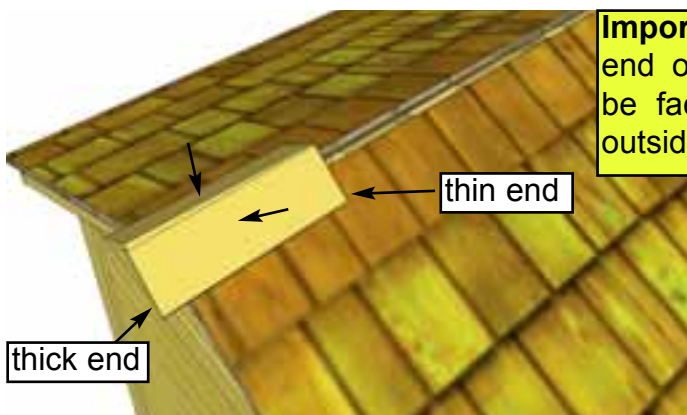

**Important:** Butt (thick) end of Ridge Cap will be facing towards the outside of shed.

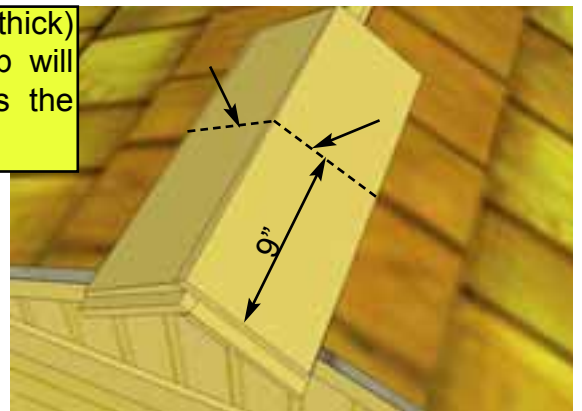

**D13.** Place First **Roof Ridge Cap** on roof peak overhanging shingles by approximately 1". Attach with **2 - 1 1/2" Shingle Nails** 9" from end. Place 2nd Ridge Cap 1" back from 1st cap. Attach with **2 - 1 1/2" Shingle Nails** 9" from end.

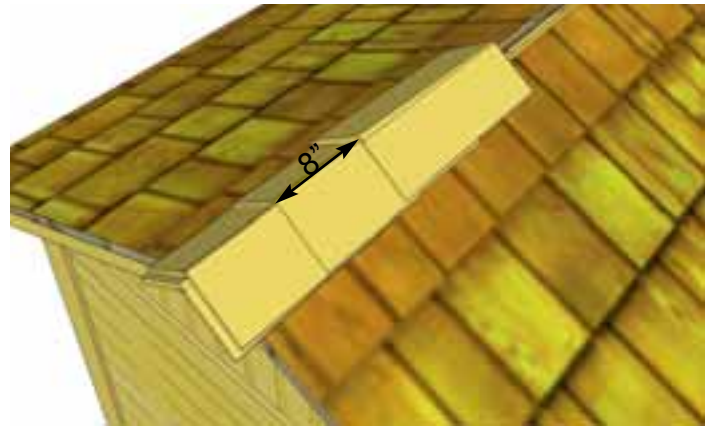
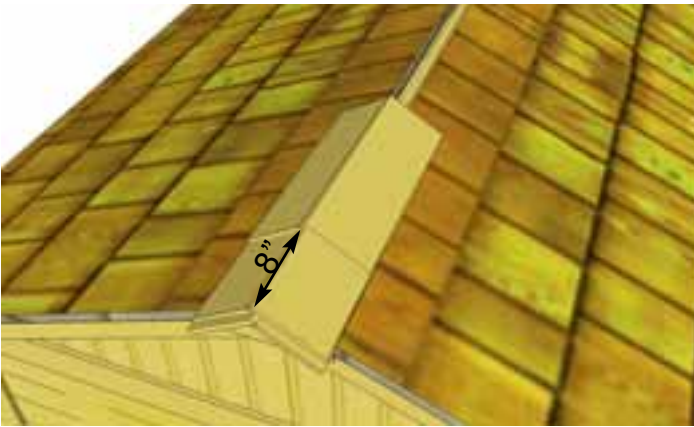

**D14.** Place 3rd Ridge Cap 8" back from 2nd (enough to cover shingle nails). Attach 3rd Ridge Cap down as per **Step D13**. Continue to position and attach Ridge Caps until half the roof is complete.

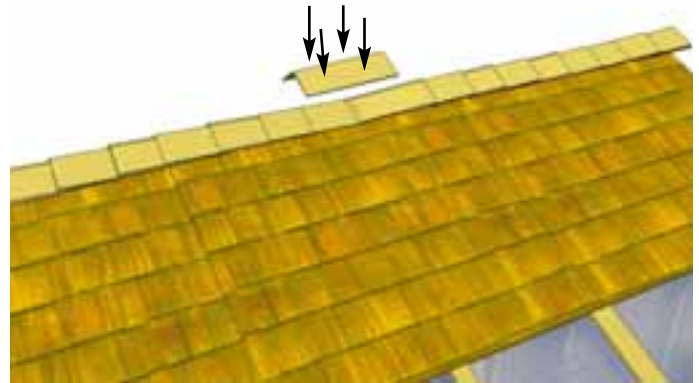
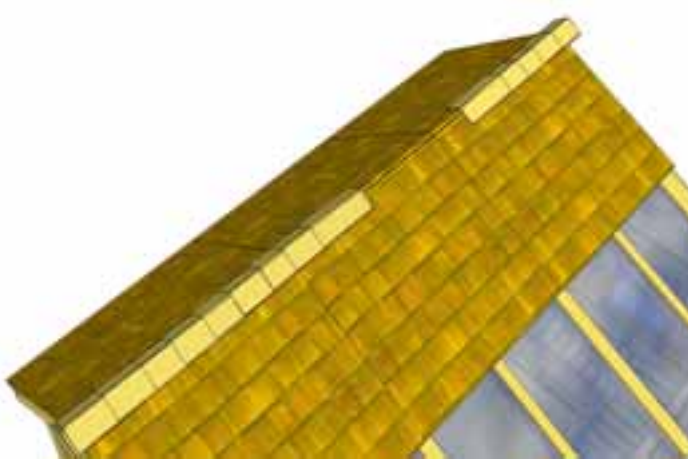

**D15.** From opposite side, position and attach Ridge Caps as described above. Score/cut 1 Ridge Cap to 12" or to fit in the center of roof. Attach center cap with 4 - 1 1/2" Shingle Nails.

# D. Roof Section - Metal

Exploded view of all parts necessary to complete the Roof Section. Identify all parts prior to starting.

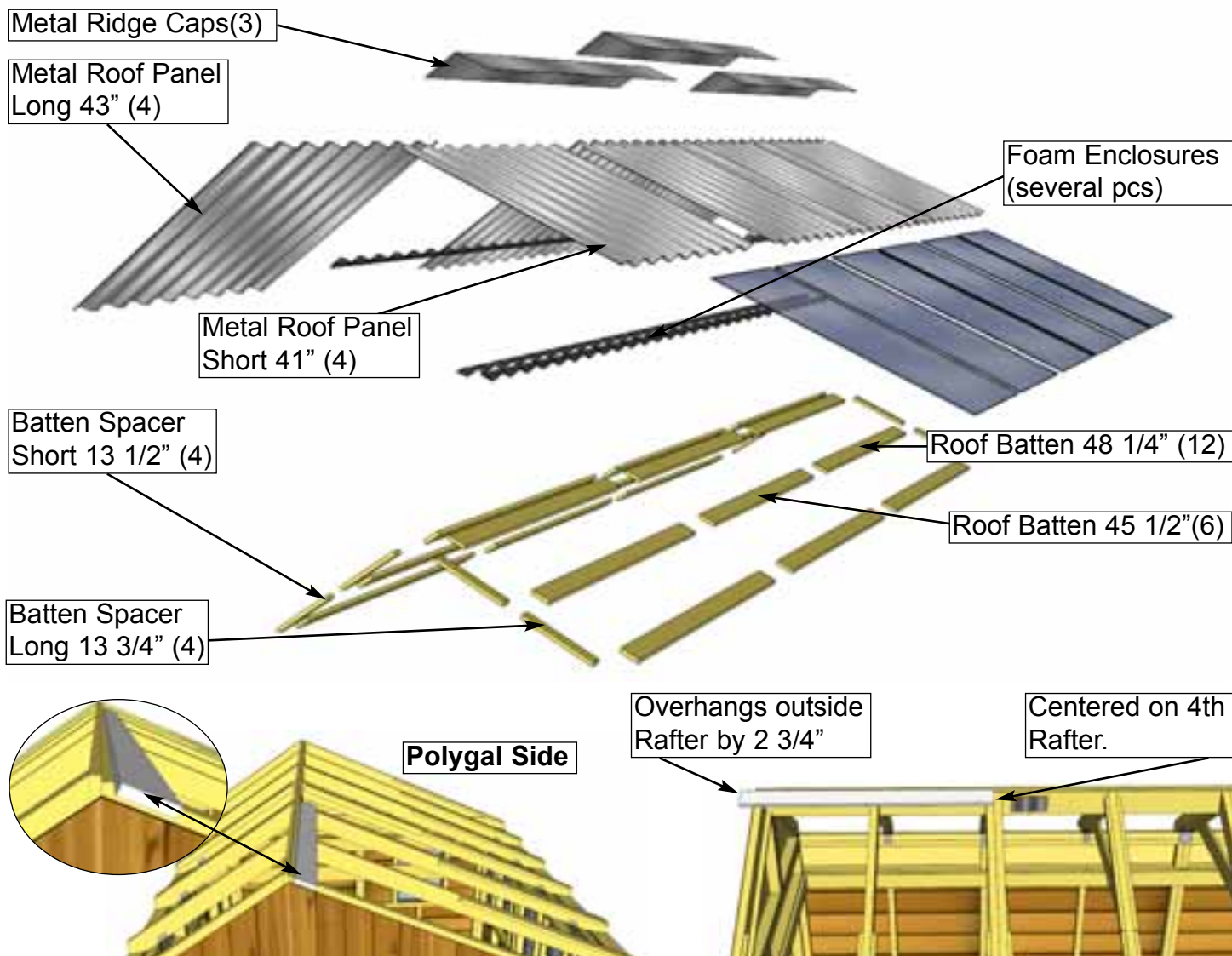

**D1.** Starting on the polygal side locate an **Outside Roof Batten (48 1/4" Long)** and place on roof rafters. Place at top of Rafter section where Rafter and Ridge Boards meet. Batten should be positioned evenly on 3rd rafter. Batten will overhang outside Rafter by 2 3/4".



**D2.** Attach **Batten** to Rafters with 3 - 1 1/4" Screws per Rafter section. **Important:** pre-drill pilot holes with 1/8" drill bit first to prevent splitting. Place **Middle Roof Batten (45 1/2" Long)** next to the first as per **Step 55** and attach with 3 - 1 1/4" Screws. Place **Outside Roof Batten (48 1/4" Long)** next to this middle batten as per **Step D1** and attach with 3 - 1 1/4" Screws.

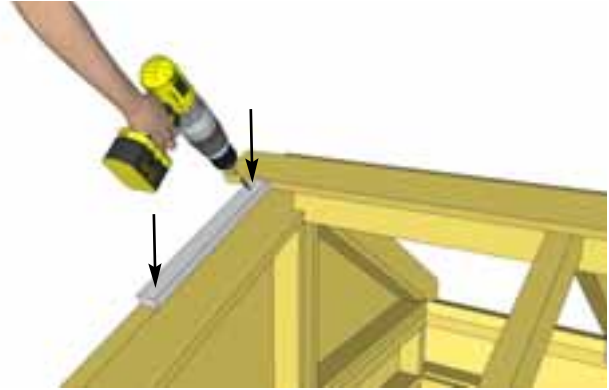
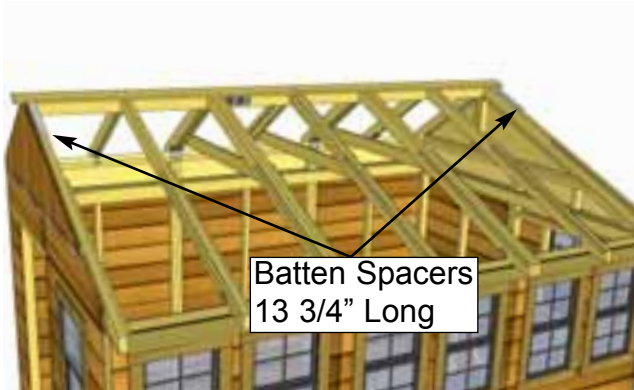

**D3.** Locate **Batten Spacers Long** ( $3/4'' \times 1\ 1/2'' \times 13\ 3/4''$ ). Place 1 spacer below each Batten lengthwise along outside Rafter. Attach each Spacer to Outside Rafter with 2 -  $1\ 1/4''$  Screws per spacer (4 total).

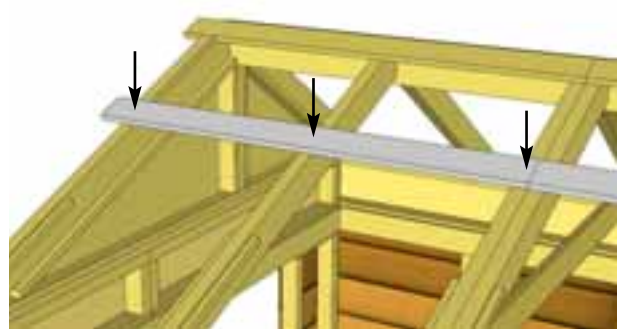
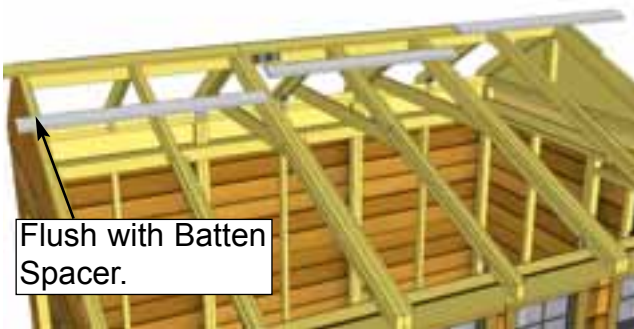

**D4.** Locate 2 **Outside Roof Battens** ( $3/4'' \times 3\ 1/2'' \times 48\ 1/4''$ ) and 1 **Middle Roof Batten** ( $3/4'' \times 3\ 1/2'' \times 45\ 1/2''$ ). Position and attach 2nd row of Battens  $13\ 3/4''$  from first row of Battens flush against Batten Spacer. Outside Battens overhang Outside Rafter by  $2\ 3/4''$  as per **Step D1**. Attach each Batten with 3 -  $1\ 1/4''$  Screws (9 total for the row).

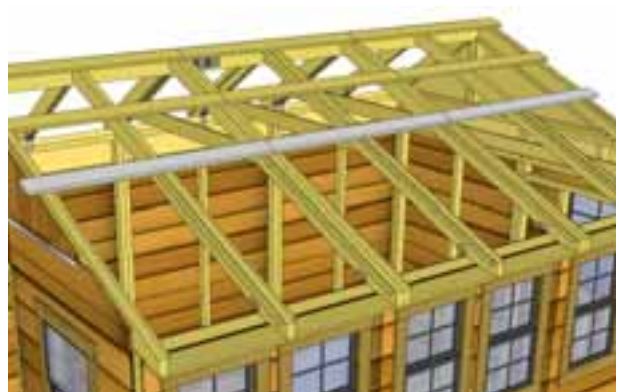
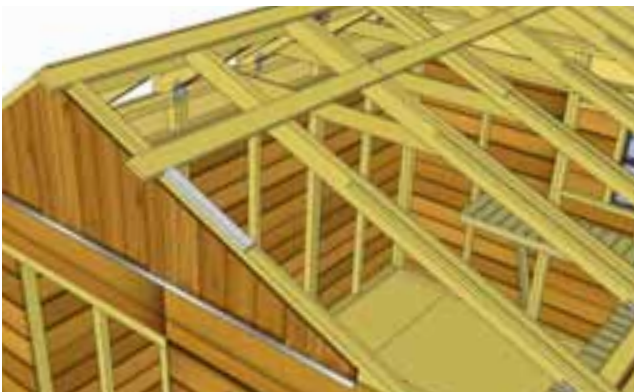

**D5.** Locate 2 more  $13\ 3/4''$  Long **Batten Spacers** and attach below 2nd row of Battens as per **Step D3** with 2 -  $1\ 1/4''$  Screws per spacer (4 total). Then locate 2 more **Outside Roof Battens** and 1 more **Middle Roof Batten** and attach as per **Step D4** with 3 -  $1\ 1/4''$  Screws per Batten (9 total).

**Short Roof Side**

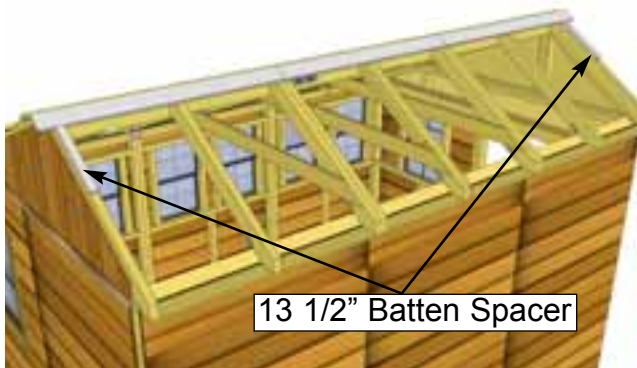

**D6.** Position first row of **Outside Roof Battens** (3/4" x 3 1/2" x 48 1/4") and **Middle Roof Battens** (3/4" x 3 1/2" x 45 1/2") on short roof side and attach as per **Steps D1 - D2**. Attach **Batten Spacer Short** (3/4" x 1 1/2" x 13 1/2") below first row of Battens. Continue attaching Spacers and Battens as per **Steps D3 - D5** until you complete all 3 rows.

**Important:** Do not fasten down Roof Panels with Hangers still in place. Metal Roof Hangers will temporarily help keep Metal Roof Panels in place before they are fastened.

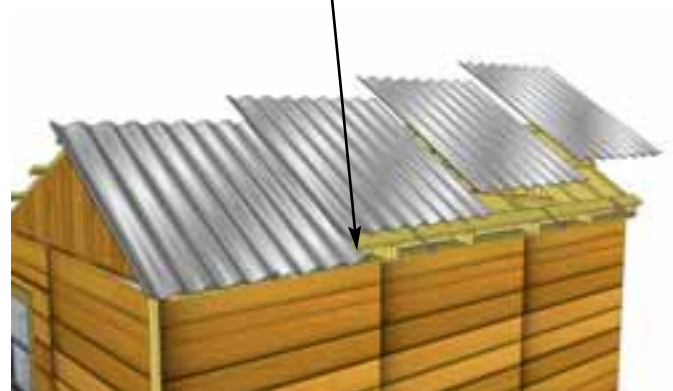
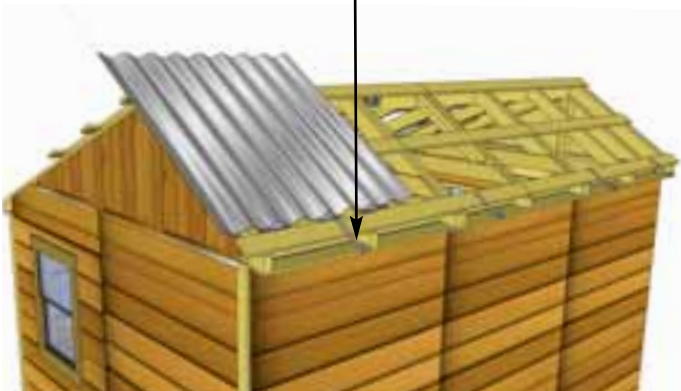
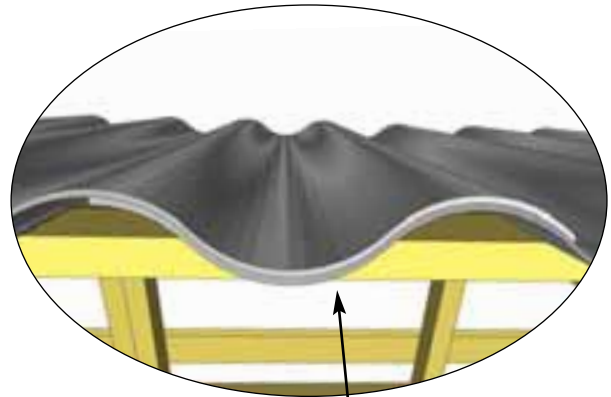
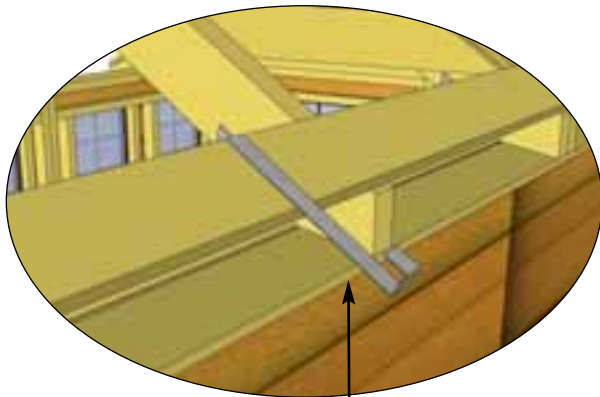

**D7.** Starting on the short roof side, locate 4 **Long Metal Roof Panels** (39" wide x 71" long) and 4 **Metal Roof hangers**. To temporarily hold the Metal Roof Panels in place, hook a Metal Roof Hanger onto the lowest Batten approximately where the center of the first panel will be. Place the first Metal Roof Panel on Battens and into Hanger. Do not fasten Panels down until **Step D12**. Place remaining 3 Panels and Hangers on the same way. Metal Roof Panels overlap each other.

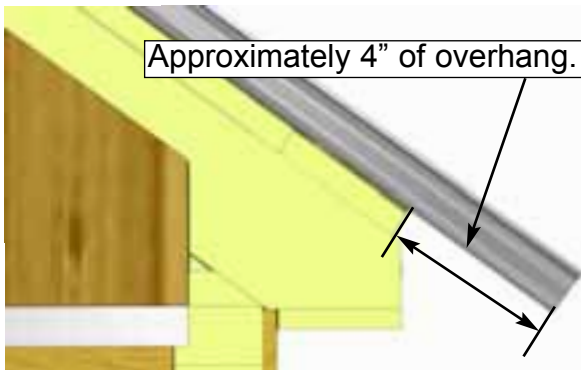

**D8.** Overhang the **Metal Roof Panels** past the **Battens** on sides by approximately 1". Adjust panels side to side to achieve desired width. Overall width past the Battens can vary from 1"- 3" depending on your preference. The overhang over the side of the shed will be set by the **Metal Roof Hangers**, but should be approximately 4" on the side of shed.

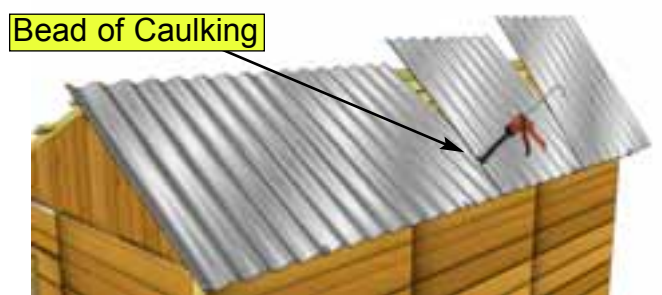

**D9.** Once Metal Roof is spaced correctly from side-to-side and top-to-bottom, lift 3 panels up and run a bead of caulking down the overlapping seams of each panel to seal the joints. Place panels down one by one once seam is caulked. You will likely need assistance from a helper for this step. Caulk each seam.

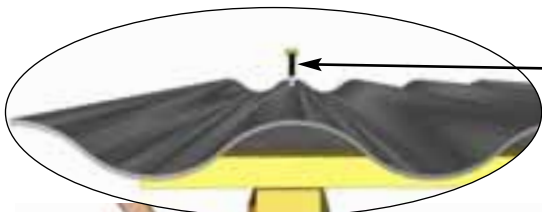

**Important:** When attaching metal roof panels, screw into peaks of roof panels and not valleys

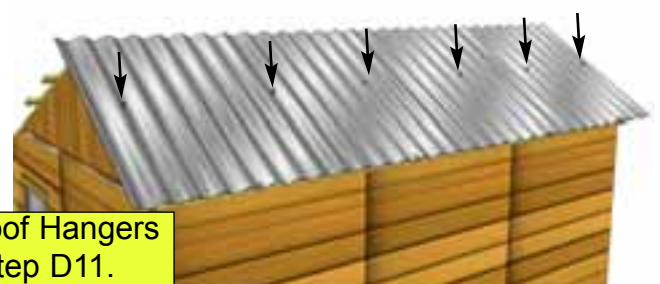

**Important:** Metal Roof Hangers will be removed in Step D11.

**D10.** Using 6 - 1 1/2" Metal Screws and 1/4" Nut Driver (included), partially secure Metal Roof Panels down to middle Batten row. Only fasten screws halfway so that Metal Roof Hangers can be removed. Metal screw is self-tapping, screw into center of Battens. Twelve more 1 1/2" Metal Screws will be required to further secure Metal Roof Panels and to complete Metal Ridge Caps in later steps once Metal Roof Hangers are removed.

**Important: Remove Metal Roof Hangers**

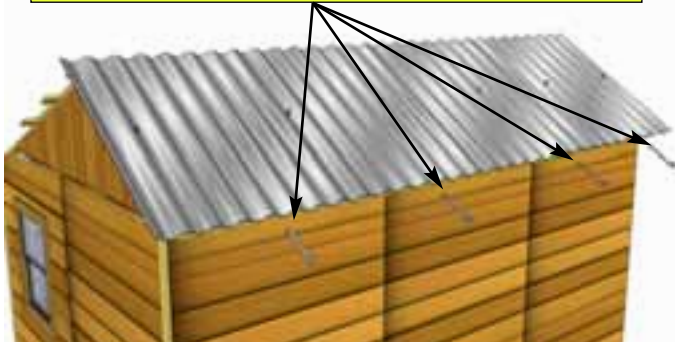

**D11.** Before fully fastening **Metal Roof Panels** down, remove the **Metal Roof Hangers** and insert **Foam Enclosures** between **Metal Roof Panels** and **Battens** at the bottom of the roof. Enclosures will prevent moisture and unwanted bugs, etc from entering your shed through here.

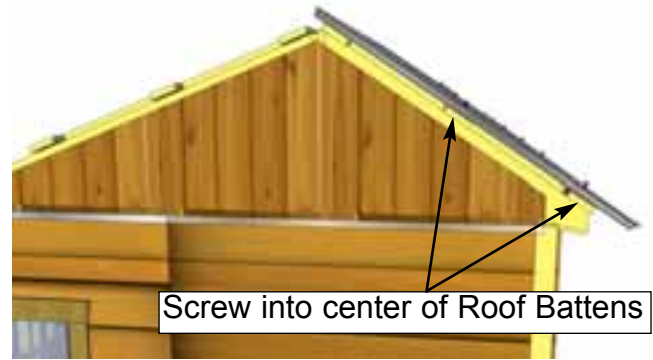
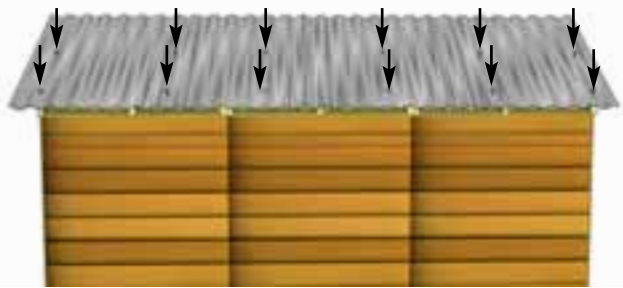

Screw into center of Roof Battens

**D12.** Using 6 - 1 1/2" Metal screws and 1/4" Nut Driver, secure **Metal Roof Panels** down to remaining lowest row of Battens. Leave the top row unsecured for now to secure Ridge Cap in **Step D16**. Tighten screws in middle row that were partially attached in **Step D10**. Do not overtighten!

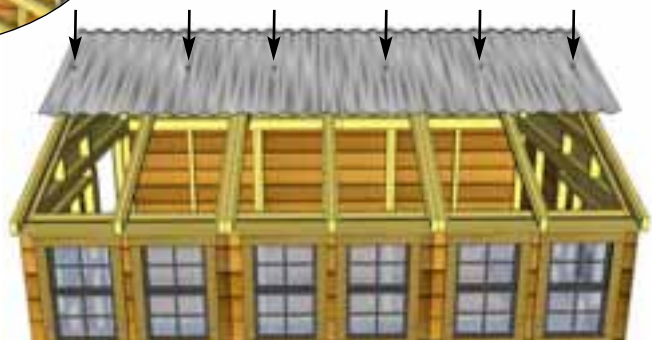
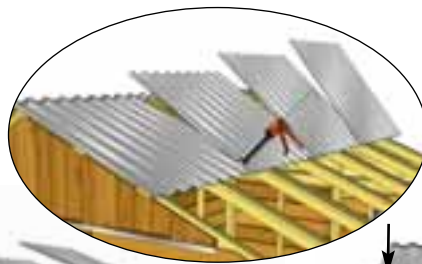

**D13.** Move to polygal side of Roof and locate **Short Metal Roof Panels (39" wide x 41" long)**. Space panels apart as per **Step D8** to match opposite side. **Short Metal Roof Panels** will overhang lowest Batten by approximately 2 1/4". Caulk seams between panels before fastening. Attach Panels to Middle row of Battens with 6 - 1 1/2" **Metal screws**. **Note:** Metal Hangers do not set length of short panel side. Use a helper to hold the short panels in place.

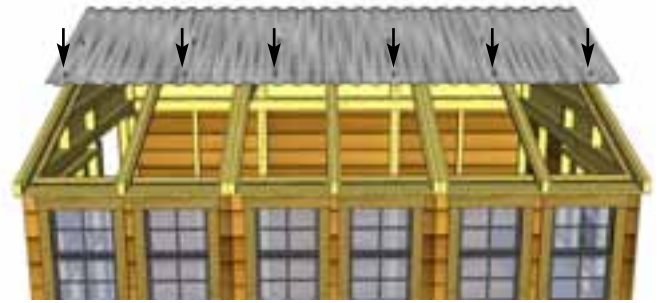

**D14.** Locate **Foam Enclosures for Metal Roof**. Insert Foam Enclosures between lowest Batten and Metal Roof Panels. Attach Roof Panel to lowest batten with **6 - 1 1/2" Metal screws**.



**D15.** Locate remaining **Foam Enclosures for Metal Roof** and **Metal Ridge Caps (60" long)**. Place Foam enclosures at the top of the roof panels. Foam Enclosures prevent moisture from coming in through the top of your shed. Place **3 - Metal Ridge Caps** onto apex of roof. Evenly space from front to back of shed. Caps will overlap each other. Overhang the cap approximately **1" - 2"** past each end.



**D16.** When Ridge Cap is correctly positioned, secure with **12 - 1 1/2" Metal Screws (6 per side)**. Screw into final Batten. Do not overtighten!

# D. Roof Section - Plywood

Exploded view of all parts necessary to complete the Roof Section. Identify all parts prior to starting.

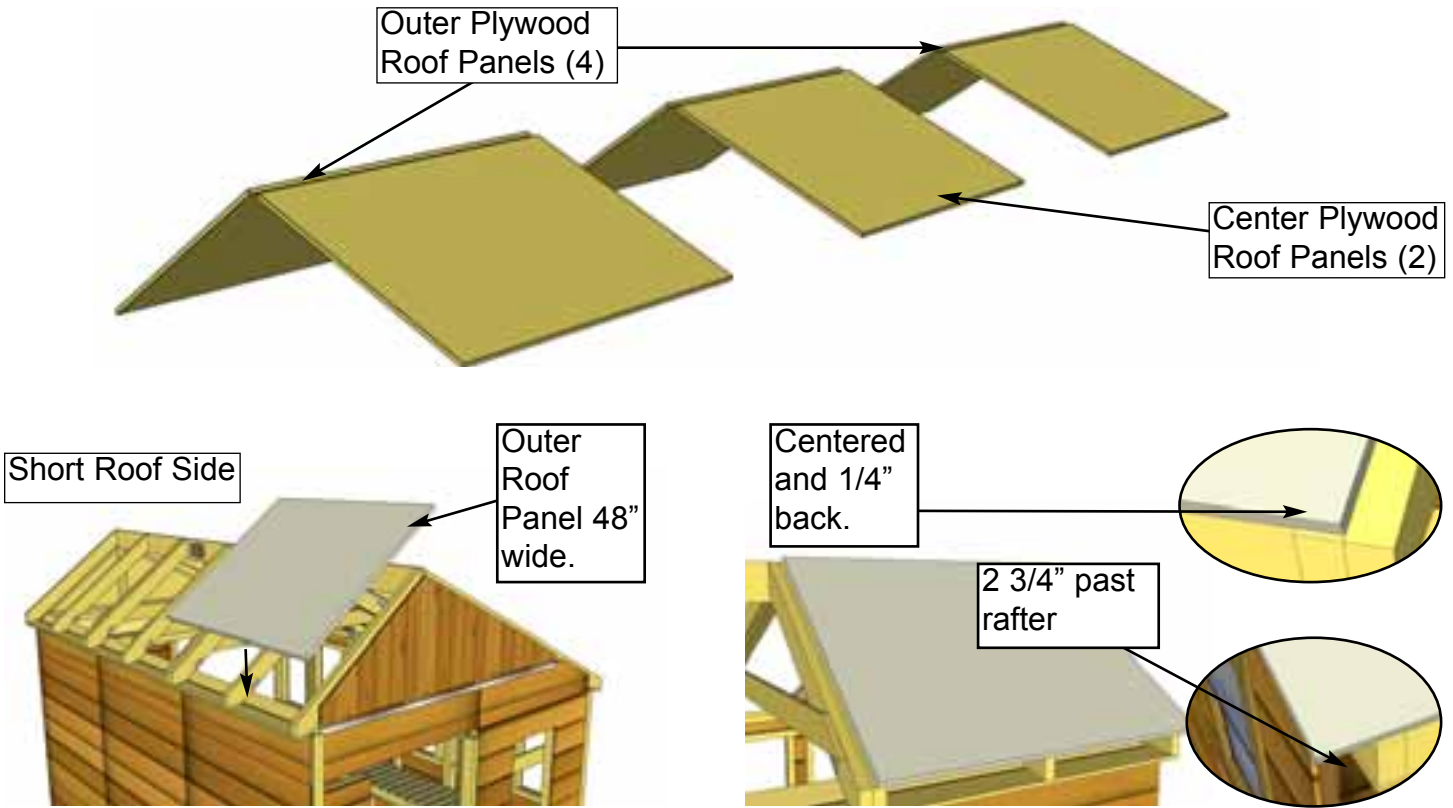

**D1.** Identify all **Roof Panels**. There are 4 Outside Panels and 2 Center Panels. The outside panels are (5/8" x 48" x 37 1/2") while the center panels are (5/8" x 45 1/2" x 37 1/2"). Starting with an Outside Roof Panel on Short Rafter Side, lift up and place on rafters so centered on mid rafter. Plywood on roof should be flush with end of rafter at bottom. Place Roof Panel so it sits flush on 3rd rafter from the outside (doubled up rafter). Plywood on roof should be flush with end of rafter at bottom. From the outside, screw down through plywood into rafter with 1 - 2 1/2" Screw. Additionally, angle a 2 1/2" Screw from outside rafter into roof plywood. Position Center Roof Panel on both doubled up rafters.

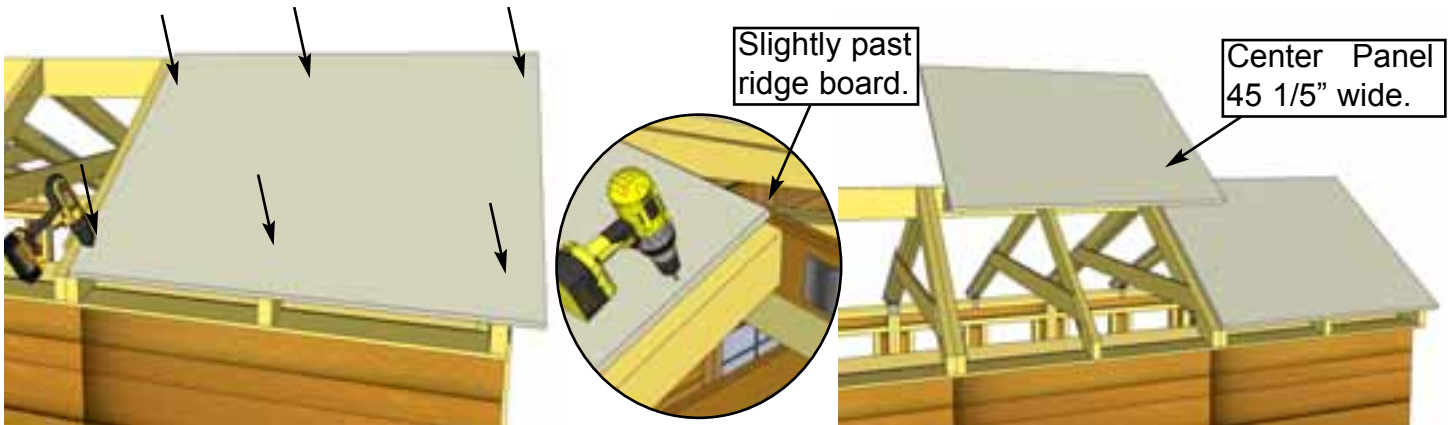

**D2.** Screw Panel to Rafters through with 6 - 1 1/4" Screw. Lift up and place a Long Center Roof Panel on Rafters (45 1/2" wide). Center Panel evenly on double rafters.

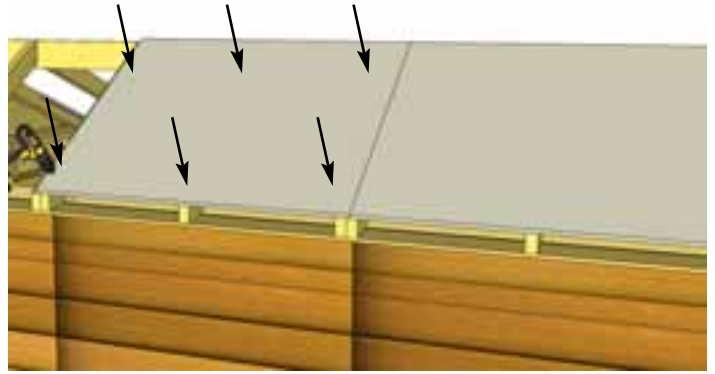
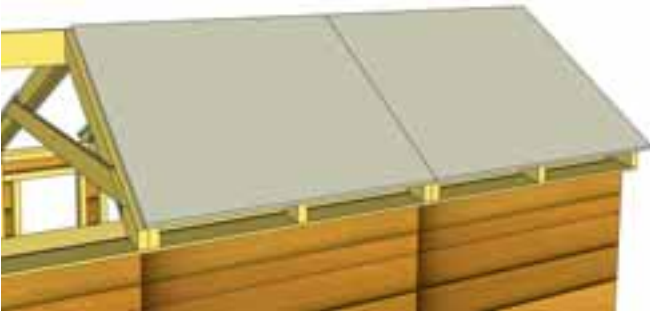

**D3.** Position Center Plywood Roof Panel so recessed back from the end of the rafters by 1/4" and attach to rafters as per **Step D2**.

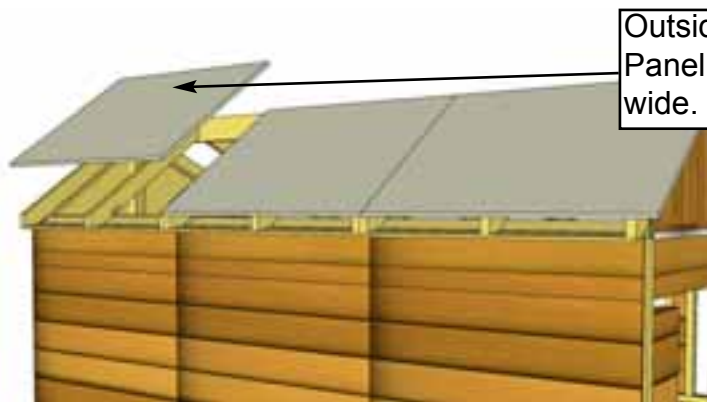

Outside Panel 48" wide.

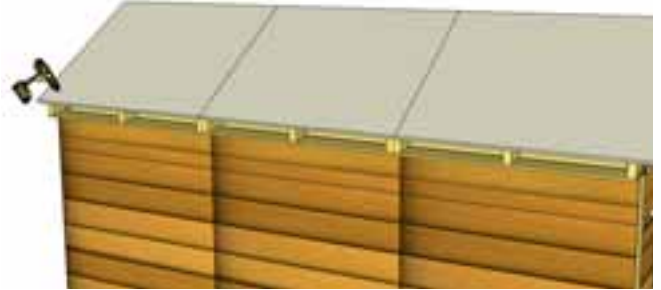

**D4.** Lift up and place remaining Outside Plywood Roof Panel on rafters. Position and attach as per **Steps D2 - D3**.

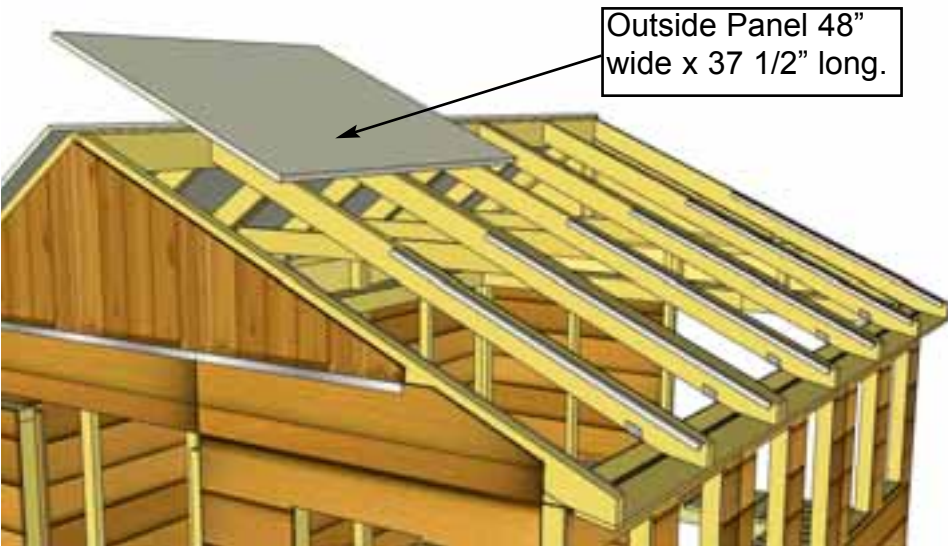

Outside Panel 48" wide x 37 1/2" long.



Small Gap

**D5.** Lift and place Outside Plywood Roof Panel (48" wide x 37 1/2" long) on Polygal Roof side. Position on rafters as per **Step D1**. Position panel so only a small gap exists at the apex of the shed.

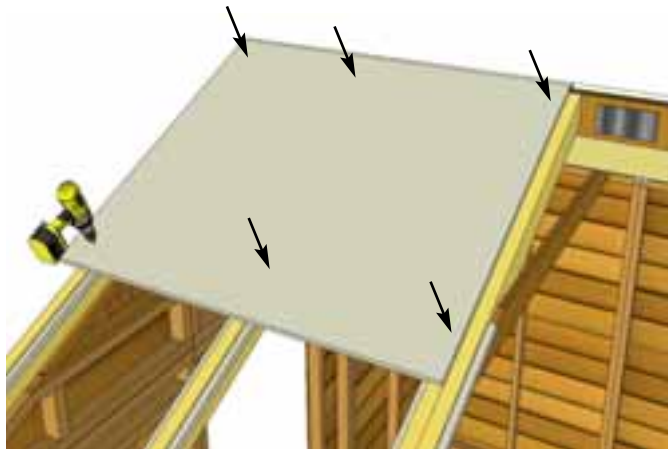

**D6.** When properly positioned, attach with 6 - 1 1/4" Screws.

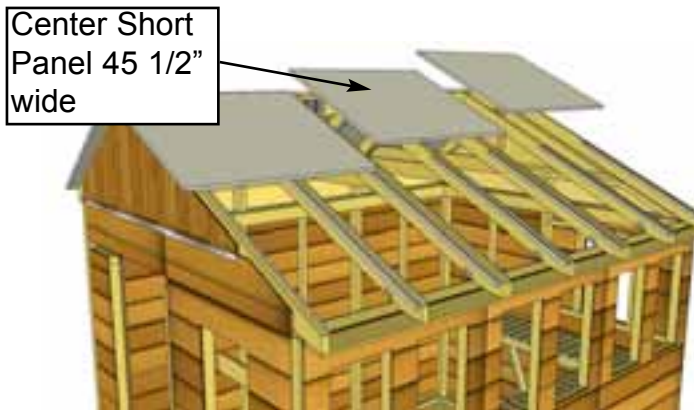

**D7.** Place Center Short Plywood Roof Panel on center double rafters as per Steps D1 - D3.

Completed Polygal Side Roof Panels

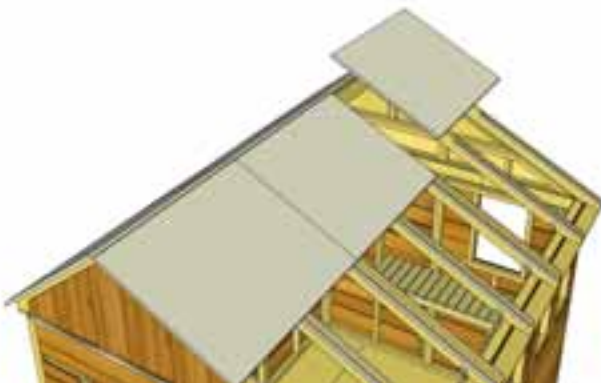

**D8.** Attach center panel as per Step 58. Position remaining Short Outside Roof Panel and attach as per Steps D2 - D3.

# D. Polygal Roof Section - Cedar/Metal/Plywood

Exploded view of all parts necessary to complete the Polygal Roof Section. Identify all parts prior to starting.

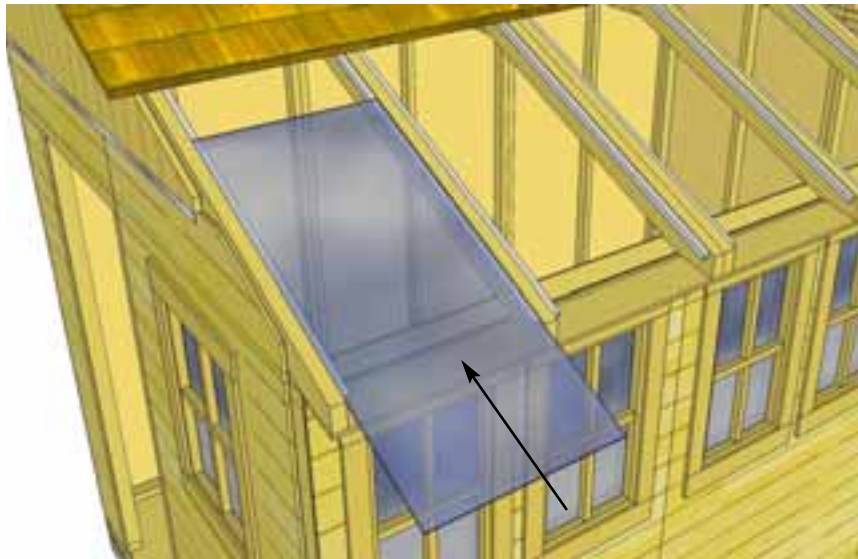
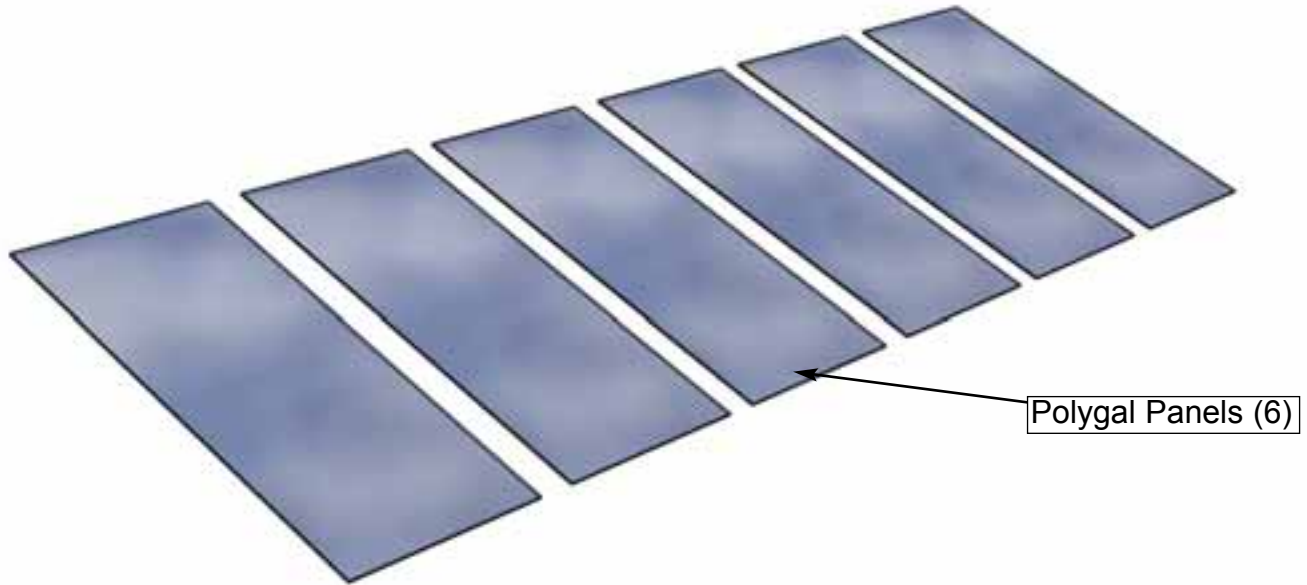

**D1.** Installation of 6 Polygal Panels is next. Start by removing protective plastic layer on each panel. Exterior/interior side of protective polygal film is printed on film, be sure to note the side and install accordingly. Slide 1st panel up between rafters so it rests on Polygal Support Cleats.

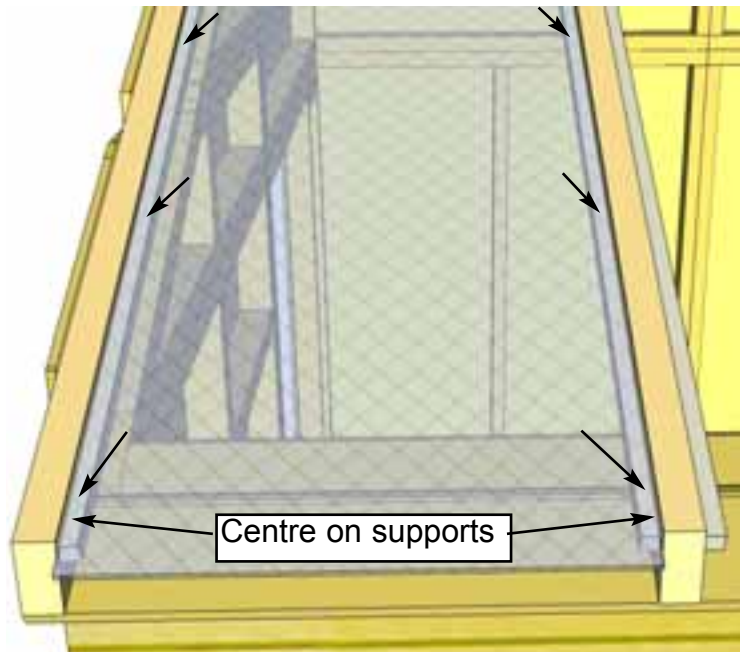

**D2.** From the inside, carefully slide end of panel underneath roof. Position Polygal Panel with equal gaps between rafters, and overhanging end of rafters by 1". With 6 - 1" Screws, secure panel to Polygal Support Cleats.



**D3.** Use 3 - 1 1/2" Finishing Nails to secure Polygal Panel to underside of roof plywood for Cedar Roof. Use 3 - 1" Screws to secure Polygal Panel to underside of Roof Batten for Metal Roof. Use 3 - 3/4" Screws to secure Polygal Panel to underside of roof for Plywood Roof.

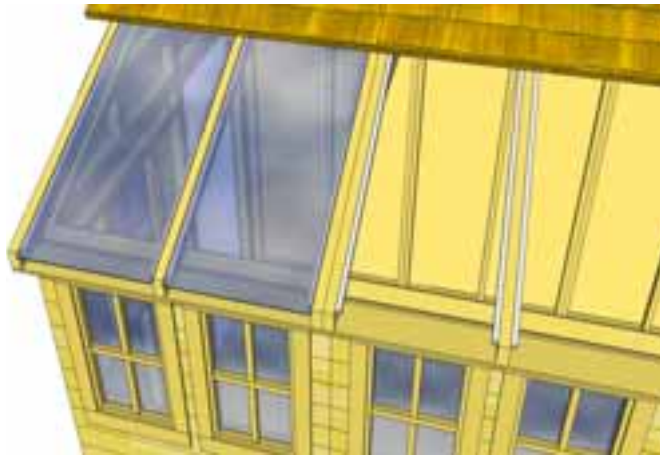

**D4.** Position and secure 2nd Polygal Panel as per Steps D1 - D3.

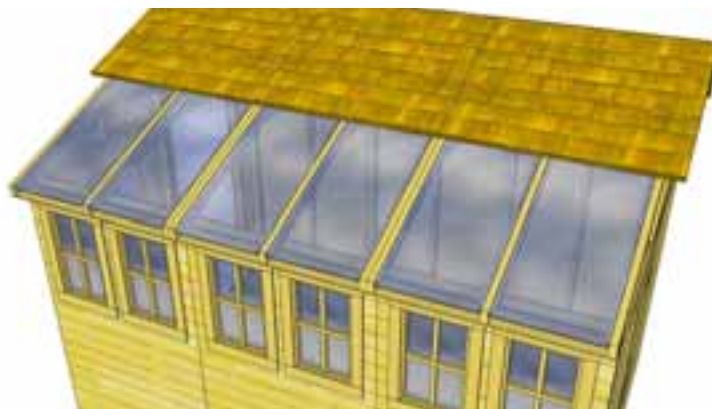

**D5.** Complete installation of remaining Polygal Panels.

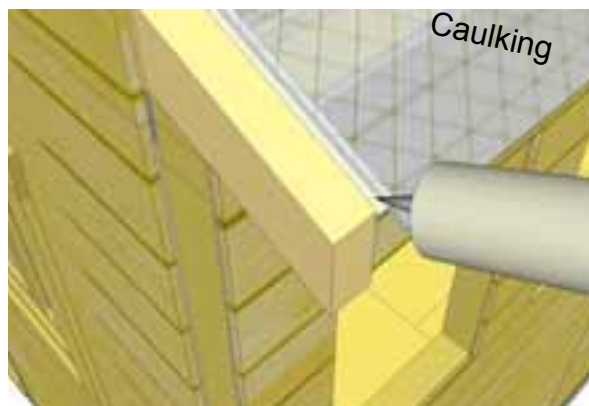

**D6.** With a Caulking Gun, apply **Silicone** to seal gaps between rafters and Polygal Panels. Apply Silicone down each side of rafter. Use liberal amounts to properly seal the gaps.

# E. Miscellaneous Section

Exploded view of all parts necessary to complete the Miscellaneous Section. Identify all parts prior to starting.

**Expert Advice:** When installing trim, sort pieces according to color and pieces that are most pleasing to the eye. Start with least visible side and use the least desirable pieces first. Install trim to most visible sides as your skill installing trim improves.

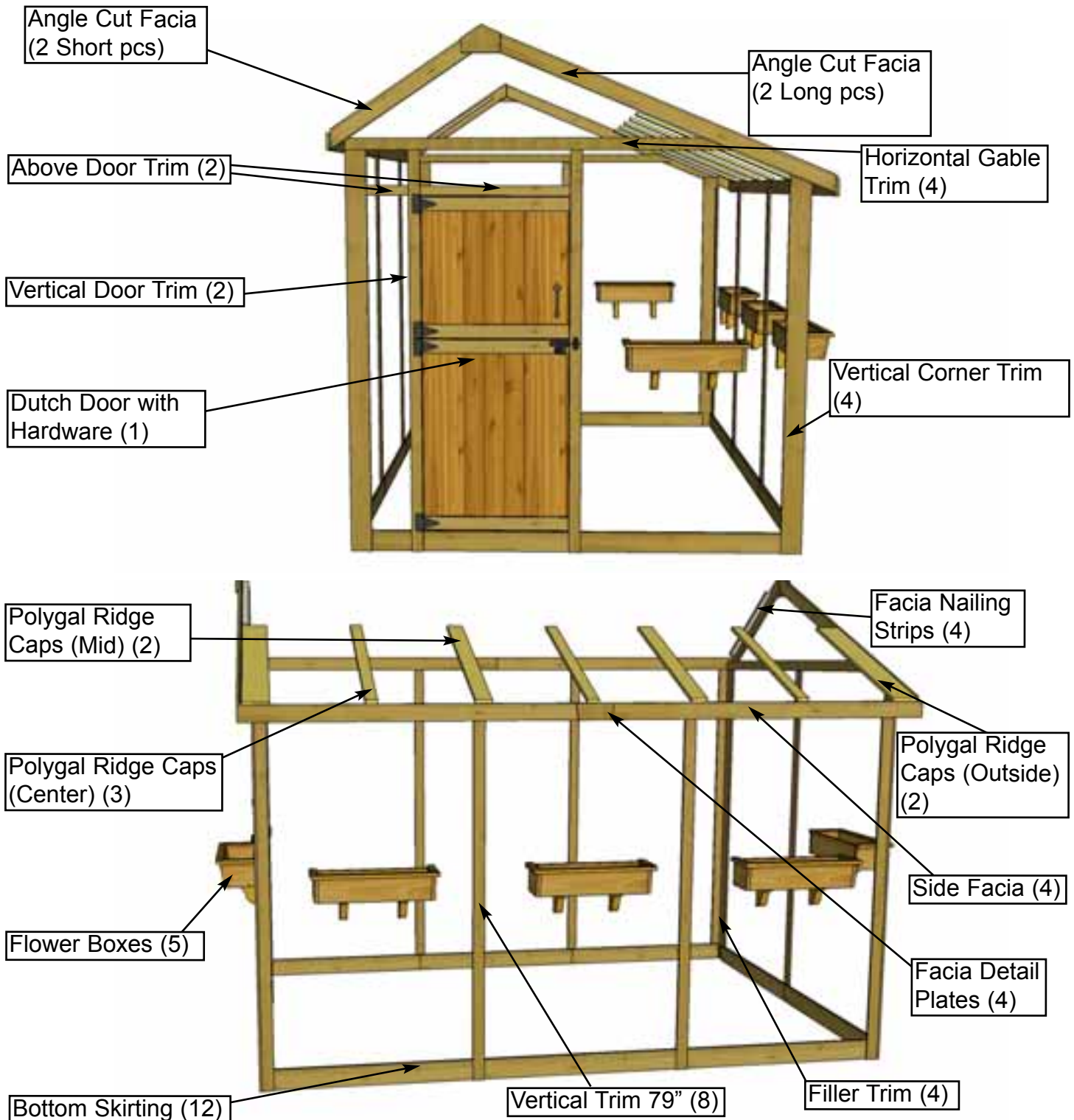

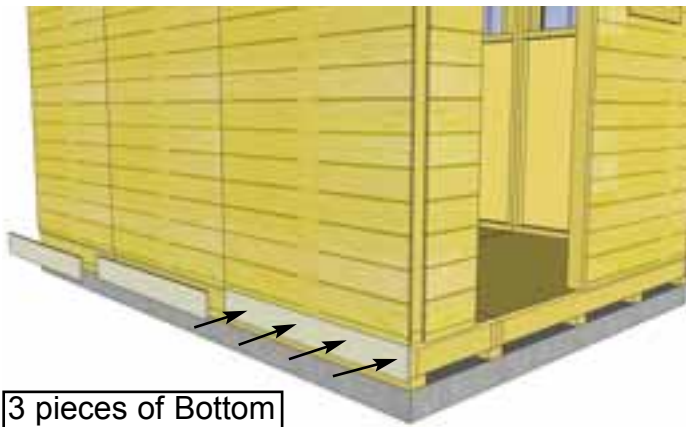

3 pieces of Bottom Skirting per side

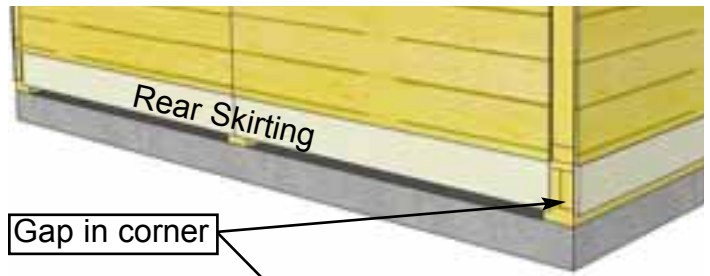

**E1.** Attach **Bottom Skirting** around the base of the shed. Skirting will hide floor framing. Gaps on outside of the front and rear walls will be covered by Wide Trim pieces later. Start with side pieces first and attach with 4 - 1 1/2" **Finishing Nails** per piece.



**E2.** Check the wall seams for visible gaps prior to attaching filler trim and apply caulk where needed. Caulking gaps will help prevent moisture from entering and will help the longevity of your shed. Caulking is included to complete Polygal Windows only. Additional Caulking may be required for gaps.

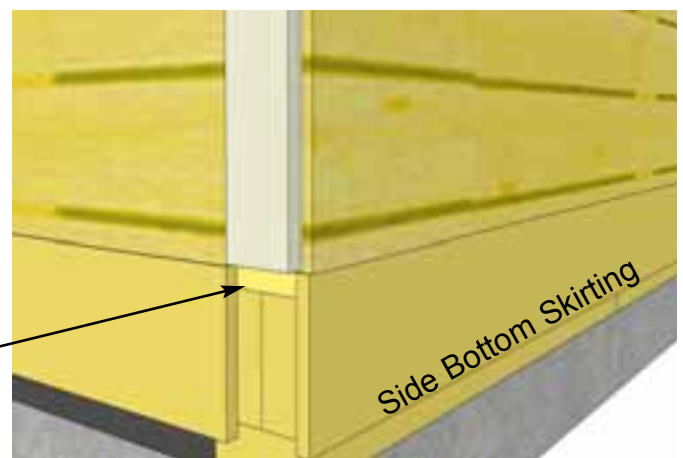

**E3.** Attach **Filler Trim - Tall and Short** to front and rear walls in each corner with 8 - 1 1/2" **Finishing Nails**. Strips are positioned flush with siding and bottom skirting. Note: Part size will vary depending on type of siding chosen for shed. See Parts List.

**COMPLETE THIS STEP ONLY FOR SHED WITH FJ SIDING**

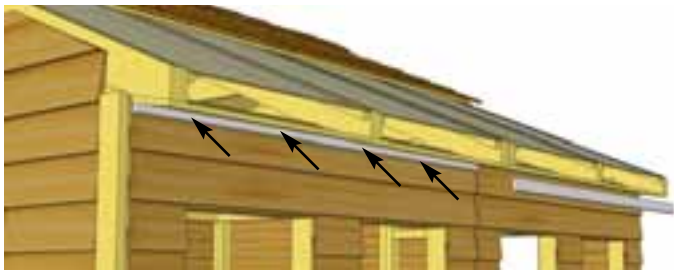

**E4.** To trim out side walls, locate Top Wall Trims. Position at top of side wall tight against roof soffit. Attach with 4 - 1 1/2" Finishing Nails per piece.

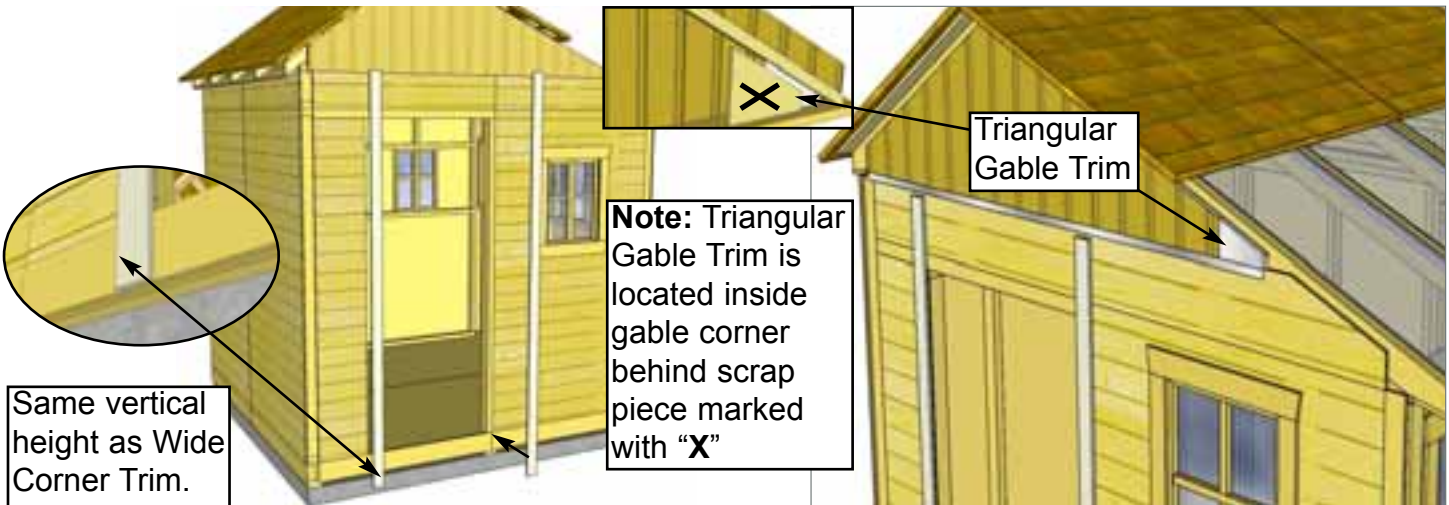

**E5.** Position 2 Door Trims on each side of door opening. Right side will sit flush with Door Jamb. Left side will sit flush on edge of Narrow wall. Attach with 8 - 1 1/2" Finishing Nails. Do a dry run with the Horizontal Gable Trim (Step E10) to confirm vertical location of Trims. Next, position Triangular Gable Trim over exposed cavity of Gable Wall on Long Roof Side. Use 2 - 1 1/2" Finishing Nails to secure into rafter. Complete for both front and rear Gables. **Important** - Gable Trim will be found stapled in the corners on inside of gables.

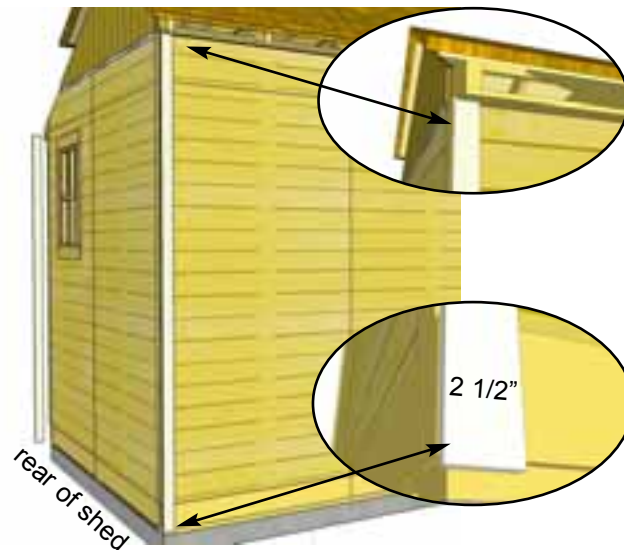

**E6.** Align and attach both Narrow and Wide Trims in each corner. Starting with a Narrow Trim (2 Short Wall & 2 Tall Wall) align tight underneath Soffit and Rafter. Position flush with Filler Trim so Wide Trim will cap it when attached in Step E7. Use 8 - 1 1/2" Finishing Nails to secure. Note that Narrow Trim will sit slightly below Bottom Skirting when correctly attached.

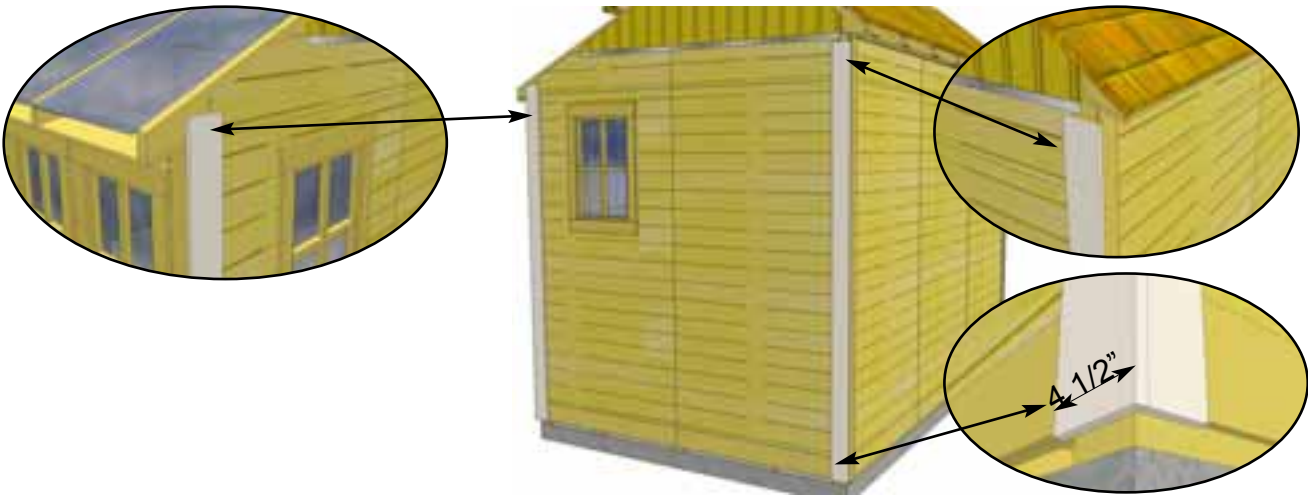

**E7.** Position **Wide Trim** (2 Short Wall & 2 Tall Wall) over Filler Trim and to cap Narrow Trim. Align Wide Trim at bottom with Narrow Trim so flush with each other. Secure trim with **8 - 1 1/2" Finishing Nails**. Complete remaining corner trims.



**E8.** Attach remaining **Narrow Wall Trims** where wall panels come together and leave a seam. **Note:** the Narrow Trim is 79" long on the Short Wall Side, 88" long on the Tall Wall Side, and 87" on the Rear Wall. Align Side Trims tight underneath Soffit and Rafter. Attach with **8 - 1 1/2" Finishing Nails** per piece. Align and attach Rear Trim as per Door Trims in **Step E5**.



**E9.** Attach both the **Horizontal Door Trim** and **Horizontal Narrow Wall Trim** with **4 and 2 - 1 1/2" Finishing Nails**.

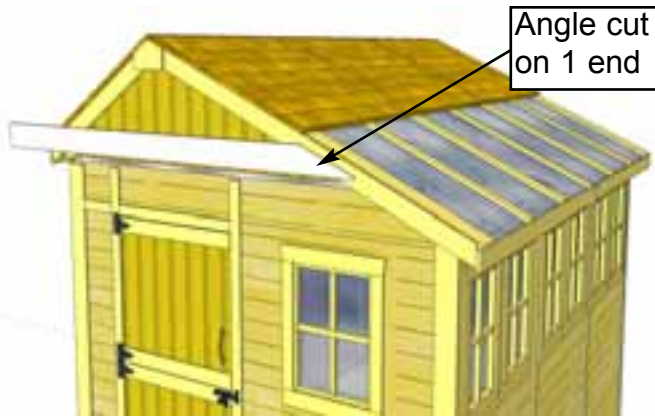

**E10.** Locate **Horizontal Gable Trim** for both front and rear of shed. Position Horizontal Gable Trim so flush with outside edge of Wide Trim and top of Vertical Door Trim. Use **8 - 1 1/2" Finishing Nails** per piece to secure. Complete both sides.

Ridge Cap slides under Roof Panel and has nailing strip attached to outside underside of it. Strips allows fascia to attach easier in **Step 86**.

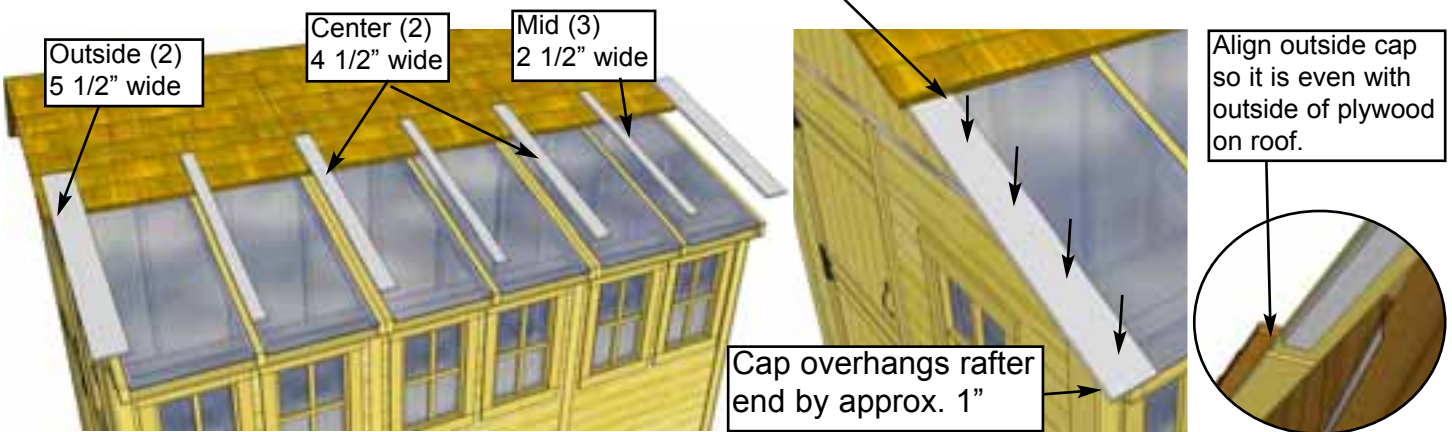

**E11.** Locate all **Ridge Caps** for Polygal Panels (3 Mid / 2 Outside / 2 Center). Starting from the outside, position both 5 1/2" wide caps so outside edge is aligned with edge of roof plywood and Cap end slides under roof. Use a straight edge to aid in alignment. When correctly aligned, attach Caps to center of outside rafter with **6 - 1 1/2" Finishing Nails**. Ridge Cap has nailing strip attached.

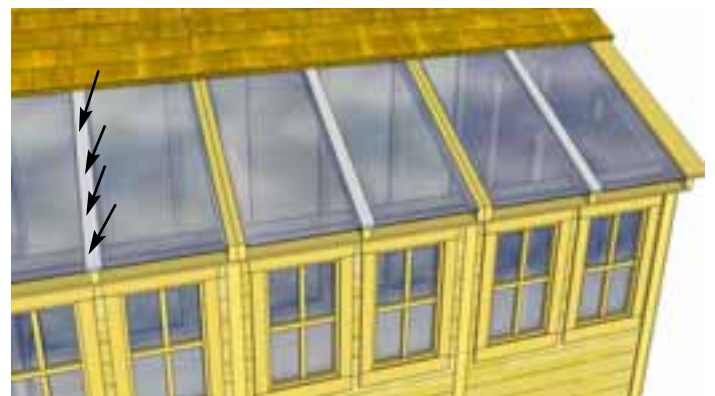
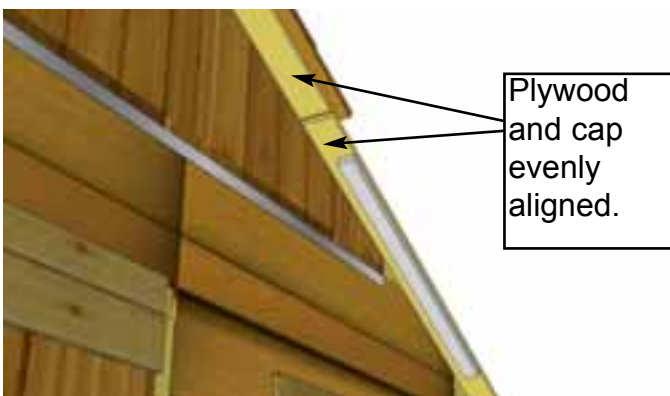

**E12.** Position and attach Mid Ridge Caps evenly spaced on mid rafters. Align top to bottom as per **Step E11**.

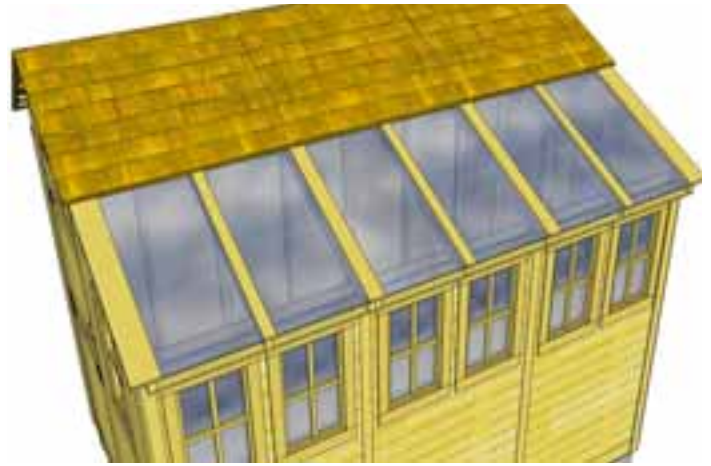
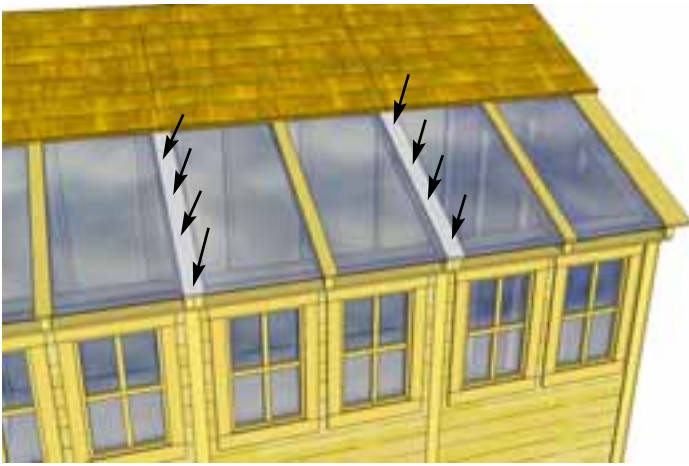

**E13.** Align and attach remaining Ridge Caps (4 1/2" wide) over Double Rafters as per Steps E11 & E12.

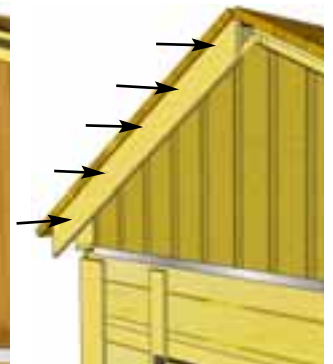

**E14.** Attach **Facia Nailing Strips** to the outside of plywood roof sheathing using **3 - 1 1/4" Screws** per piece. Do all outside roof panels. Starting with the **Short Roof** side, attach **Front and Rear Facia** to end of roof plywood with **5 - 1 1/2" Finishing Nails** per side. Facia end lines up with rafter ends. Do a dry run with side facia in **Step E15** before attaching.

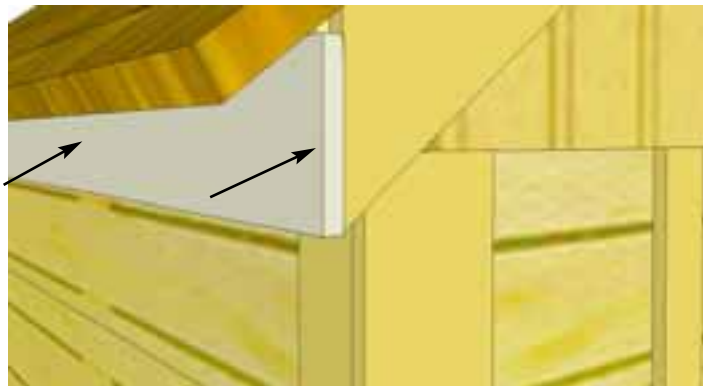
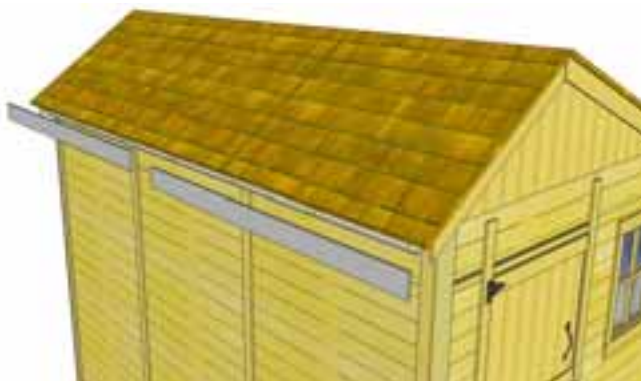

**E15.** Attach **Side Facia** to roof rafter ends. There are 2 pieces per side. Secure with **8 - 1 1/2" Finishing Nails** per piece. Side Facia will sandwich Front and Rear Facia. Do a dry run with Front, Rear and Side Facia to confirm correct positioning prior to attaching.

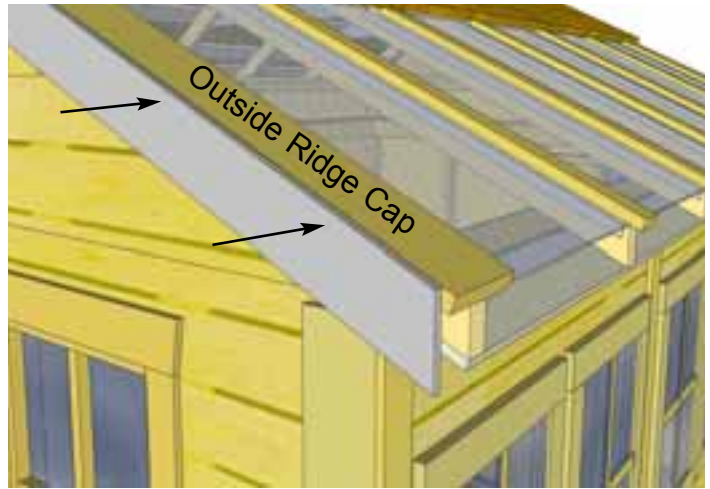

**E16.** Attach Long Front and Rear Facia to roof plywood and Outside Ridge Cap edge with 10 - 1 1/2" Finishing Nails and 2 - 1 1/2" Screws. Use screws where Outside Ridge Cap and Facia meet. Once again, Line Facia up so it is aligned with rafter ends. Do a dry run with Front, Rear and Side Facia to confirm correct positioning prior to attaching.

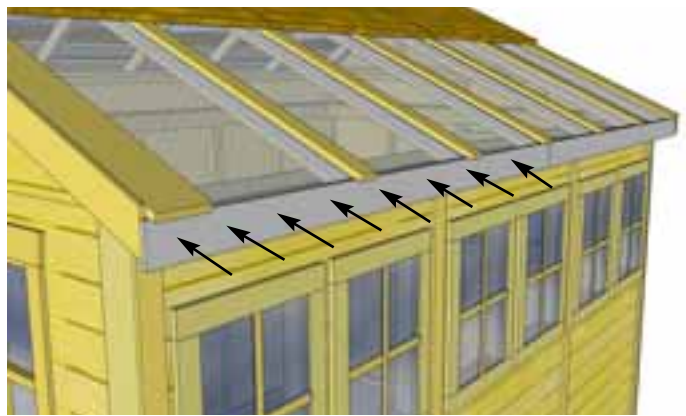
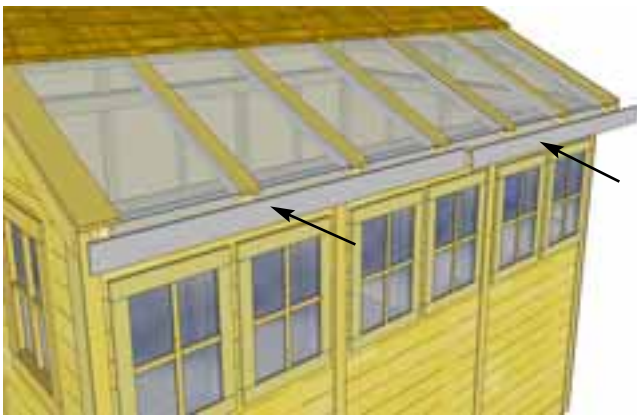

**E17.** Attach remaining Side Facia to roof rafter ends as per Step E15.

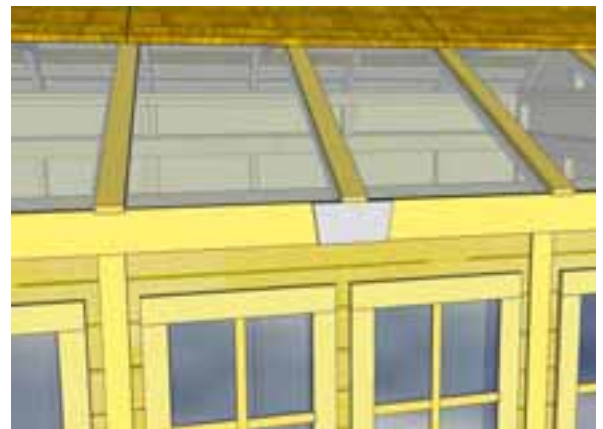

**E18.** Attach Facia/Trim Detail Plates and Pentagon Detail Plates to cover seams where facia trim pieces come together. Secure each with 4 - 1 1/2" Finishing Nails.

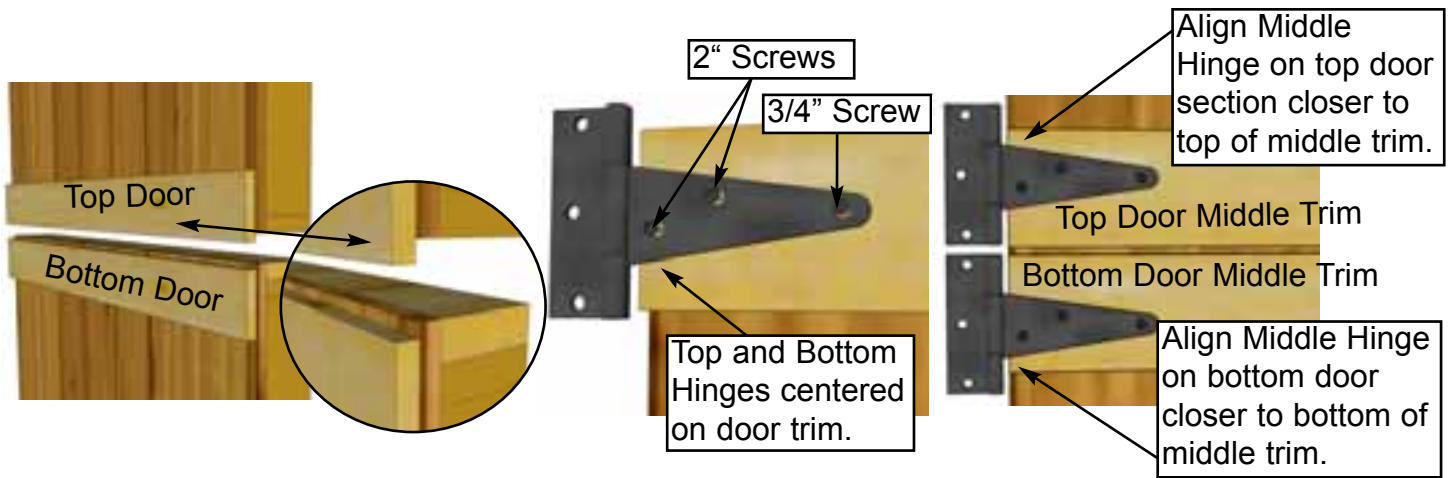

**E19.** Attach Door Hinges to **Top** and **Bottom Dutch Door** sections. Top Door section has middle trim overhanging door at bottom while bottom door section has middle trim recessed slightly. Top and Bottom Hinges should be centered on door trim. Align the middle hinge for the top door section closer to the top of the middle door trim. Align the middle hinge for the bottom door section closer to the bottom of the middle door trim. Middle hinges should not overlap. Position middle hinges accordingly. Use **2" & 3/4" Black Headed Screws** as shown above.

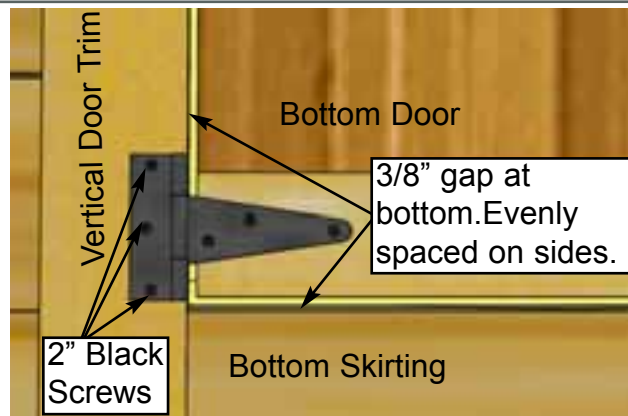

**E20.** Place Bottom Dutch Door panel into position. Gap  $3/8"$  on bottom, evenly space on sides, and attach hinge to doorway seam trim with **2" Black Headed Screws**. Use shim to help keep the door evenly spaced on bottom. One of the extra roof shingles (see parts list) can be used.

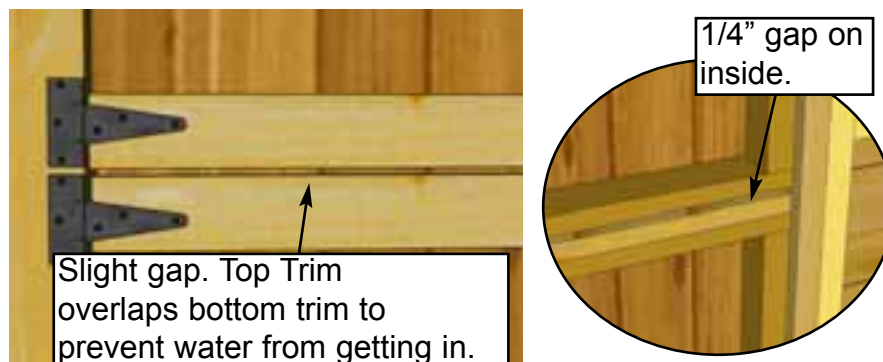

**E21.** Place the Top Dutch Door Panel into place and gap top and bottom trims on the outside about  $1/8"$  apart. On the inside, horizontal door frames should be about  $1/4"$  apart. Use a shim once again to help you. Attach hinges to trim with **2" Black Headed Screws** provided.

**Important:** Drill pilot holes with 1/8" drill bit prior to securing with screws to prevent wood splitting. On 3/4" screw, drill shallow pilot hole only.

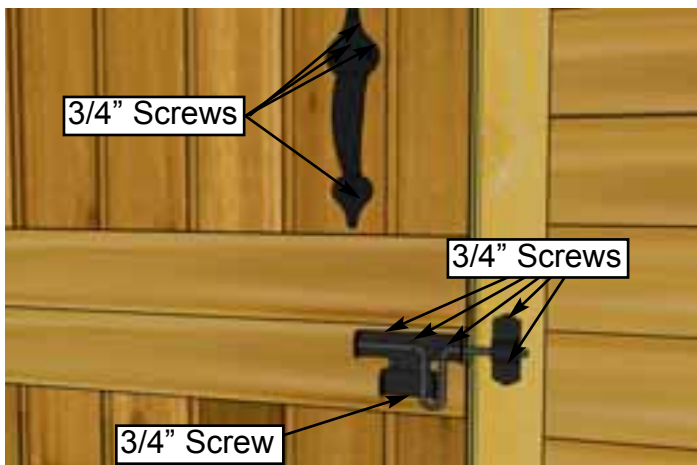

**E22.** Attach **Door Handle** and **Exterior Black Drop Latch** to door. Handle is positioned on top door, Drop Latch on bottom door. Attach Black Drop Latch as illustrated above with **6 - 3/4" Black Headed Screws**. Note how female part of Drop Latch is positioned higher than male. Do a dry run first to position Drop Latch correctly. Attach Handle with **4 - 3/4" Black Headed Screws**, ensure screws connect with inner door stud. Attach Interior **Silver Barrel Bolt** to inside of door as illustrated above. Use **3/4" Silver Screws** to secure.

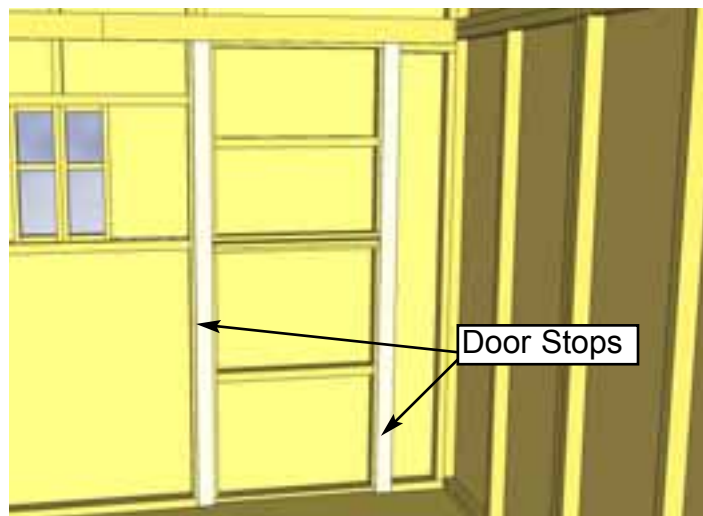
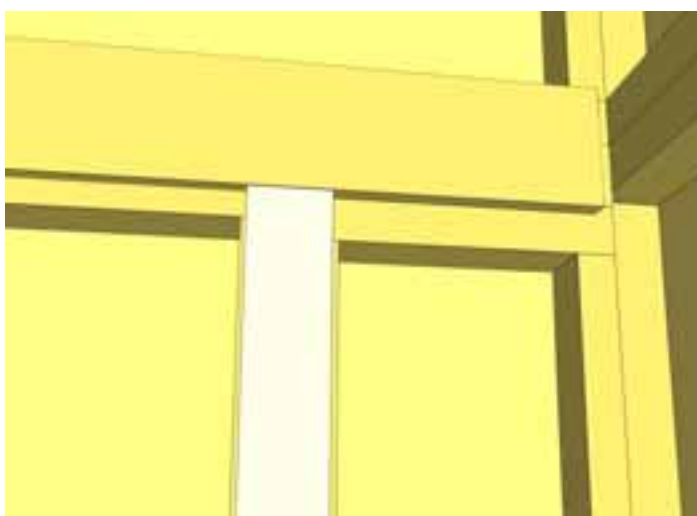

**E23.** Attach **Interior Vertical Door Stops** to door framing from inside of shed. Use **4 - 2" Screws** to secure each Stop. Stops should overlap door by approx. 1/2".



Dab caulk in siding channel on both sides of window.

Run caulk in siding gap at top. Requires a large amount.

**E24.** Locate **Window Inserts for Double Window Walls**. Before installing, dab caulk in channel on both sides of window opening. This will prevent water from getting in behind window. Position window in cavity. **Important:** Pre-drill holes in filler strip at top of window with 1/8" drill bit before fastening window inserts. Secure with **8 - 1 1/4" Screws**. Caulk gap between siding and window at top. This requires a large amount of caulking but is important to fill. Later, Window Trims will be installed to hide caulking. Complete for **Regular Window Walls**.

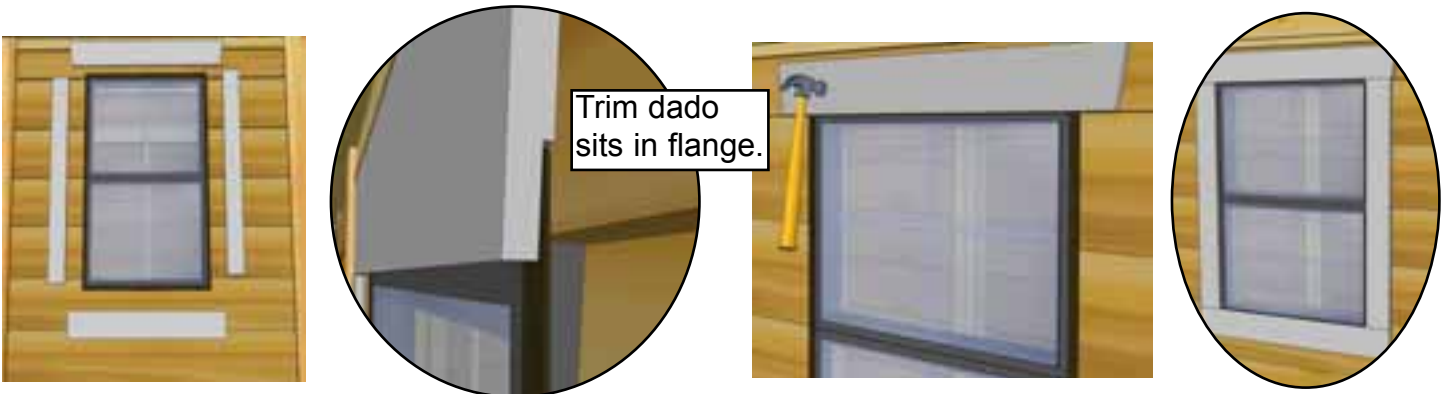

Trim dado sits in flange.

**E25.** Position Window Trim around window doing a dry run first and attach with **4 - 1 1/2" Finishing Nails** per piece. There are two Trim Kits (Regular / Narrow). The regular window kit = 1 x 24 1/16" = top (angle cut on ends) / 3 x 23" = Sides & Bottom. Narrow window kit = 1 x 19 7/8" Top, 2 x 21 7/16" Sides, 1 x 18 3/4" Bottom. Window trim has a small dado on reverse face. Outside flange of window will roughly sit in the dado to give a better fit.

**E26.** Assemble **Flower Box Kit** with Assembly Instructions included on Page 57. Position completed Flower Box below bottom of window trim and secure with **2 - 2 1/2" Screws**. Screw from inside of box into the center wall stud. Attach second screw 2" underneath first screw and once again into the wall stud. Install Flower Box Kits underneath each window.



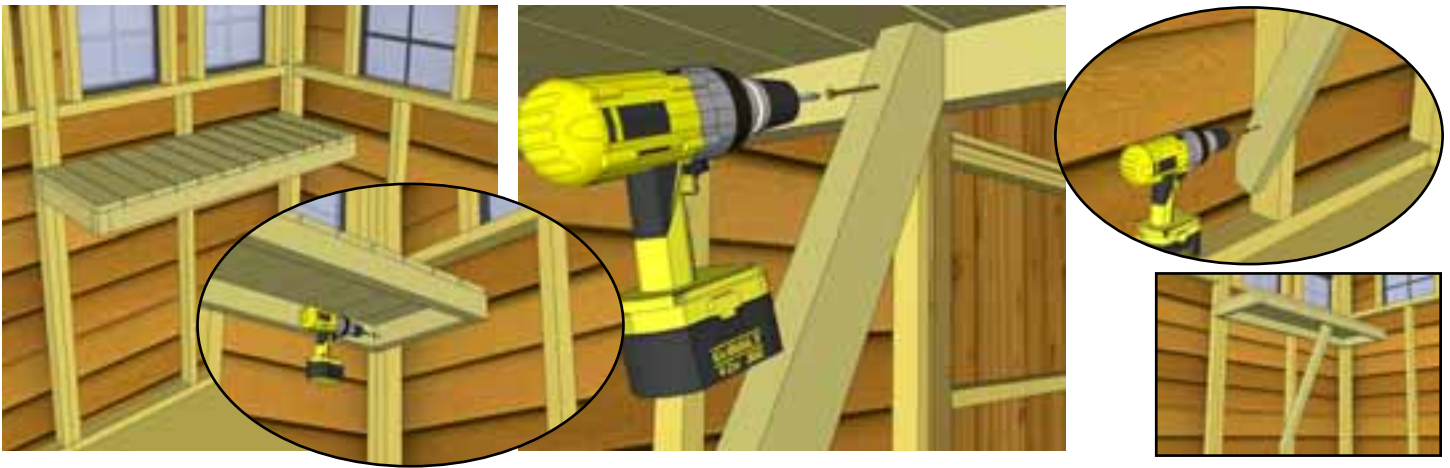

**E27.** Locate 1 Long Potting Shelf and 1 Leg. Position shelf in corner tight against wall framing. While supporting the shelf, attach shelf with 2 1/2" Screw. Place leg underneath shelf and attach to inside shelf frame and wall framing as illustrated above with 2 1/2" Screws.



Completed Potting Shelf

**E28.** Place Short Potting Shelf against wall framing and end of long shelf framing. Attach with 2 1/2" Screws as per Step E27. Use a level to confirm shelving is square and level. Attach leg as previously illustrated. Screw to wall stud and up into the underside of the of shelf framing. Complete attaching remaining long shelves as per Steps E27 & E28.

# Outdoor Living Today Flower Box Assembly Instructions

## Parts Lists:

<b>A - Base, Rear &amp; Front Box Frames (3pcs)</b>	3/4" x 5 1/2" x 23"
<b>B - End Cap Frames (2pcs)</b>	3/4" x 5 1/2" x 7" / 8"
<b>C - Front Trim (1 pc)</b>	3/4" x 1 1/2" x 26"
<b>D - Side Trims (2 pc)</b>	3/4" x 1 1/2" x 8 3/4"
<b>E - Brackets (2 pc)</b>	1 1/2" x 5 1/2" x 5 1/2"
<b>F - 1 1/4" Screws (15 pc)</b>	
<b>G - 1 1/2" Nails (10 pc)</b>	

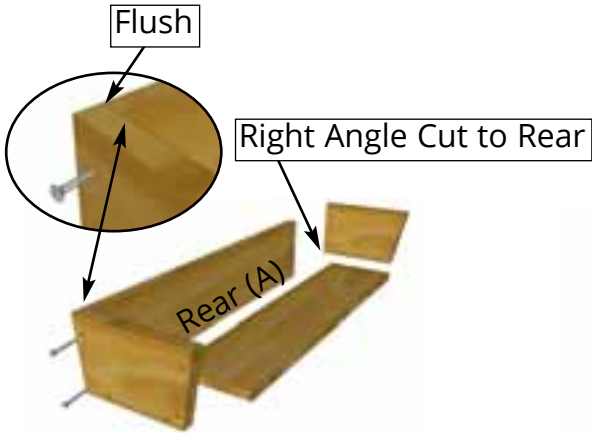
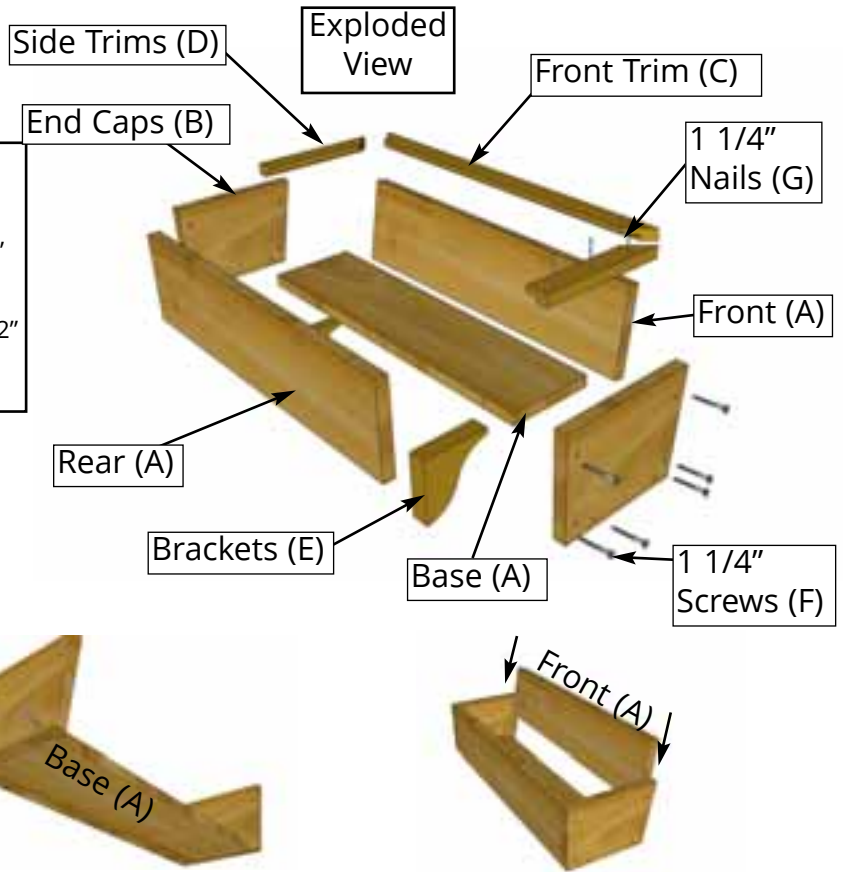

**1.** On a table position Rear Box and End Cap Frames together so flush at top. Fasten together with 2 - 1 1/4" screws. Place Base Frame tight against Rear and End Cap and flush at bottom. Secure with 2 - 1 1/4" screws. Complete attachment of

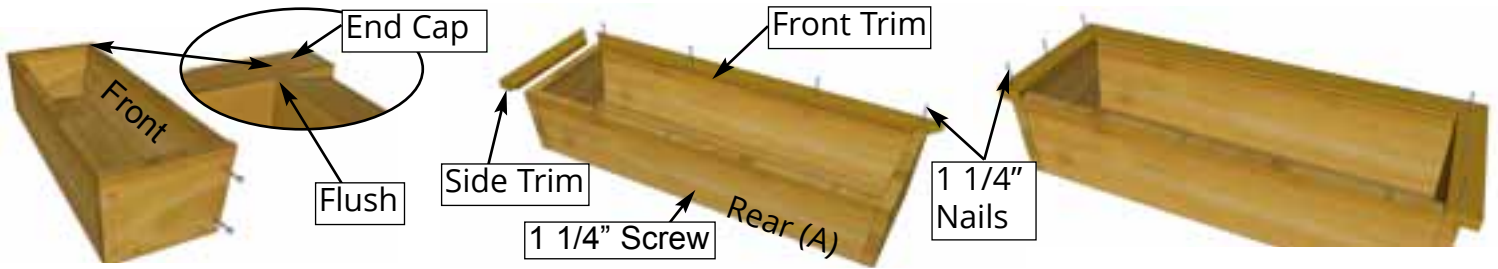

**2.** Position Front Frame Piece flush with End Cap. Attach both ends with 2 - 1 1/4" screws. Pilot hole Rear Box Frame near bottom center and secure to Base edge with 1 - 1 1/4" screw. Evenly position Front Trim (mitre cut on end and dado cut on inside bottom) tight against front frame and nail down with 4 - 1 1/4" nails. Position Side Trims as per Front and secure with

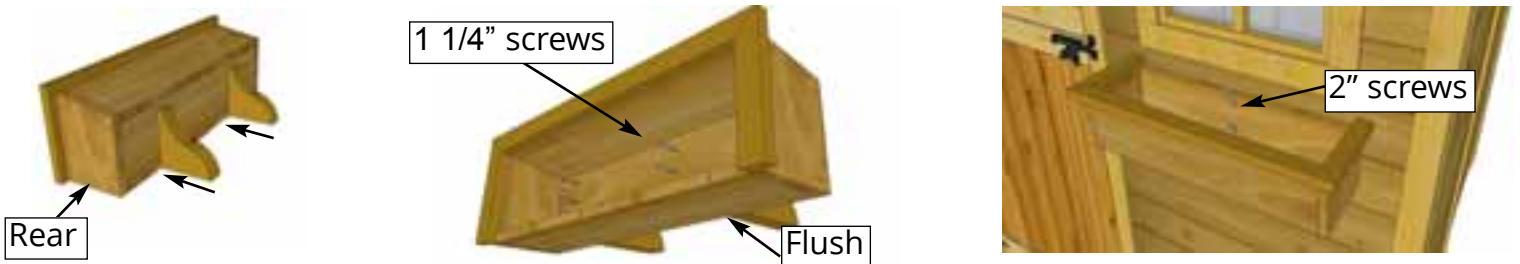

**3.** On a flat surface, flip Flower Box on it's rear face. Evenly space Brackets and secure through Base Frame and into the Brackets with 2 - 1 1/4" screws per Bracket. Position completed Flower Box beneath window trim and screw from inside of



# Outdoor Living Today



Congratulations on  
assembling your  
8x12 Sunshed!

**Note:** Our Sheds are shipped as an unfinished product. If exposed to the elements, the lumber will weather to a silvery-gray color. If you prefer to keep the lumber looking closer to the original color, we suggest that you treat the wood with a good oil base wood stain. You may also wish to paint your new shed rather than stain it. In both cases we recommend that you consult with a paint and stain dealer in your area for their recommendations.

We hope your experience constructing our **8x12 Sunshed** has been both positive and rewarding. We value your feedback and would like to hear back from you on how well we are doing in the following areas:

1. Customer Service
2. On Time Shipping
3. Motor Freight Delivery
4. Quality of Materials
5. Assembly Manual
6. Overall Satisfaction



The materials contained in this Assembly Manual may be downloaded or copied provided that ALL copies retain the copyright and any other proprietary notices contained on the materials. No material may be modified, edited or taken out of context such that its use creates a false or misleading statement or impression as to the positions, statements or actions.

Please call, write or email us at:

Canadian Address  
9393 287th Street  
Maple Ridge, British Columbia  
Canada V2W 1L1

United States Address  
P.O. Box 96  
Sumas, Washington  
USA 98295

Toll Line: 1.888.658.1658

| Fax: 1.604.462.5333

| [sales@outdoorlivingtoday.com](mailto:sales@outdoorlivingtoday.com)