

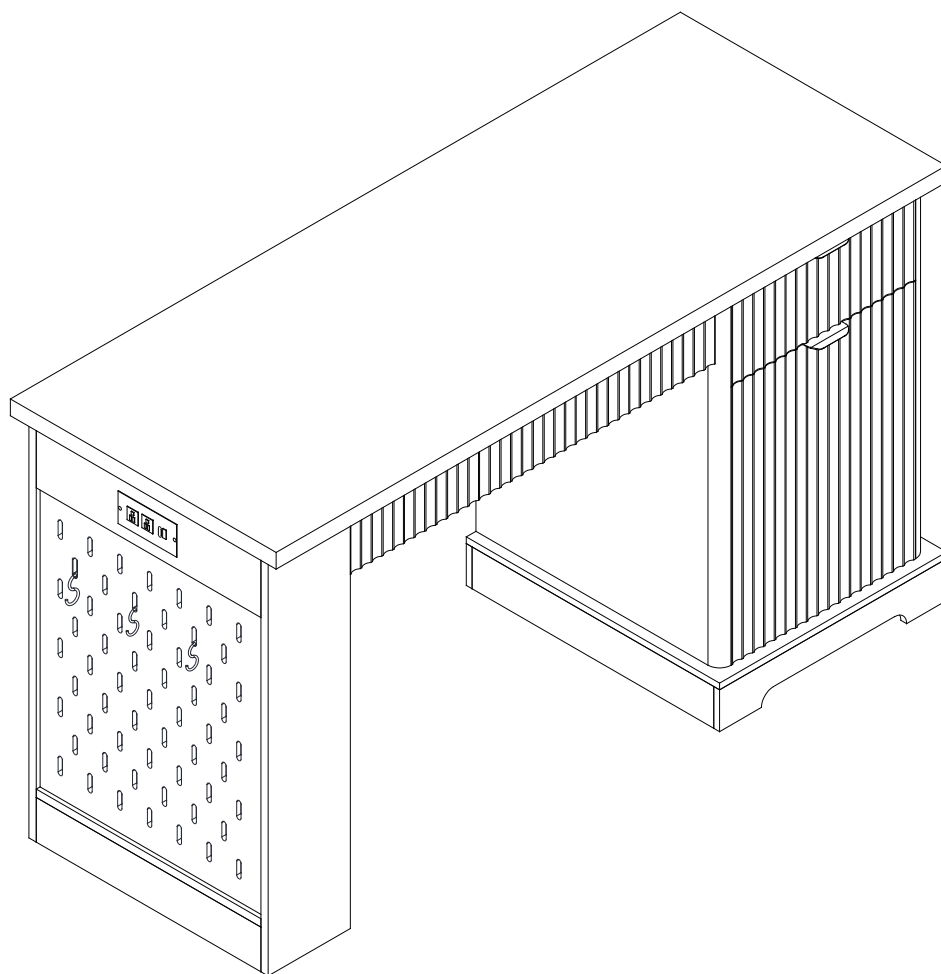

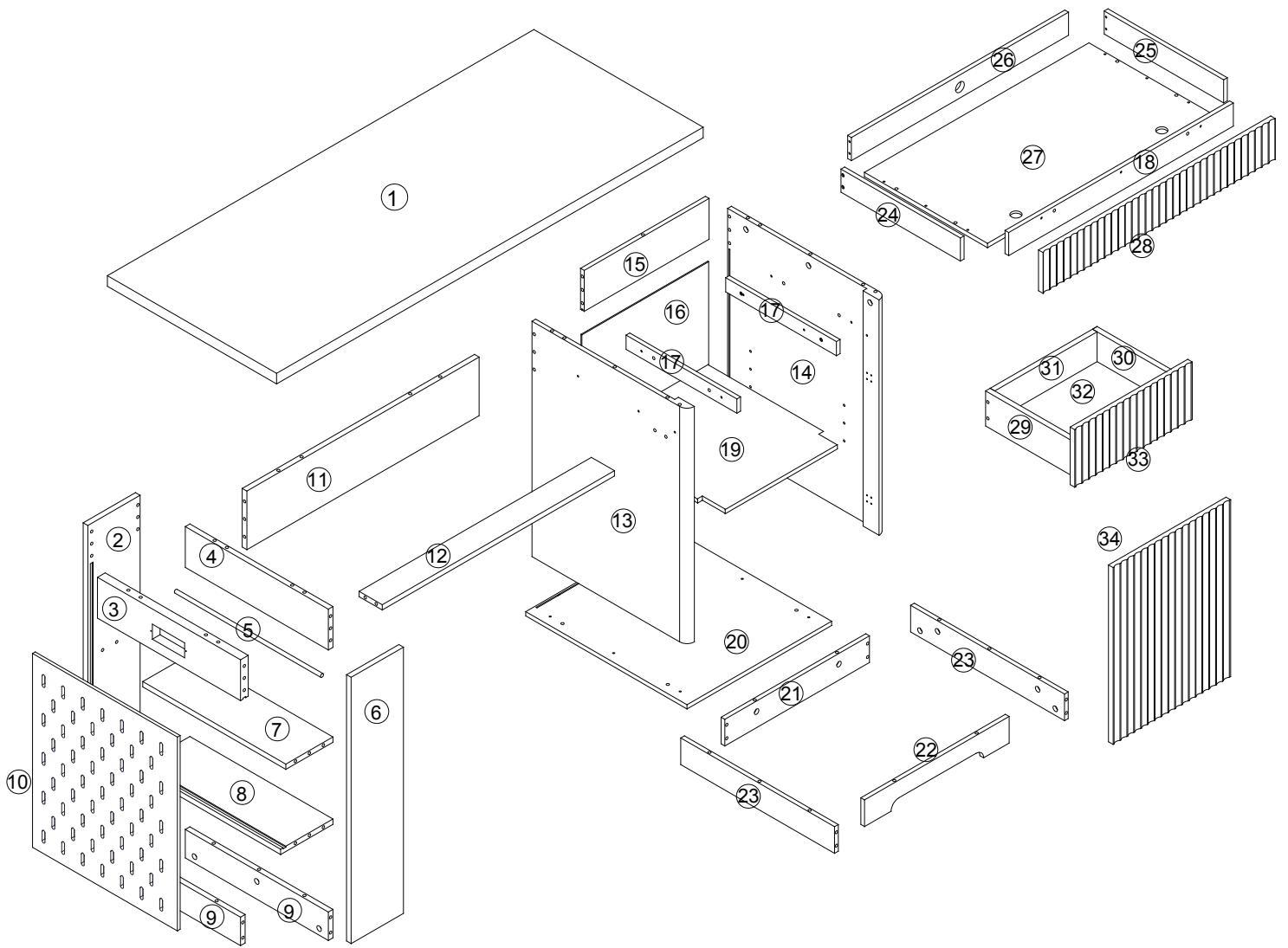

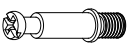







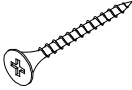
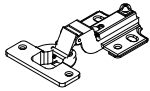

ASSEMBLY INSTRUCTION

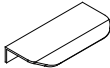
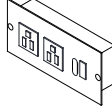

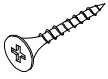
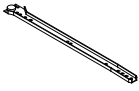
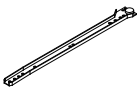
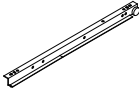
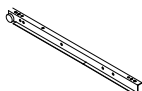

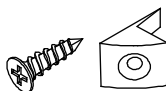

Hardware List

 A x 55+2	 B x 55+2	 6x30 C x 50+2	 3.5x12 D x 28+2	 4x40 E x 18+2	 F x 2	 G x 2
 4x12 H x 22+2	 6x20 I x 6	 4x20 J x 3	 K x 2	 L x 1	 M x 3	 4x25 N x 4
 CL x 2	 CR x 2	 DL x 2	 DR x 2	 O x 4	 P x 8	 R x 2

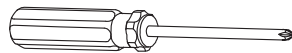
ASSEMBLY TOOLS REQUIRED(NOT INCLUDED)
OUTILS DE MONTAGE NÉCESSAIRES (NON INCLUS)



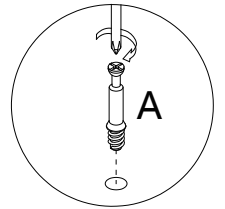
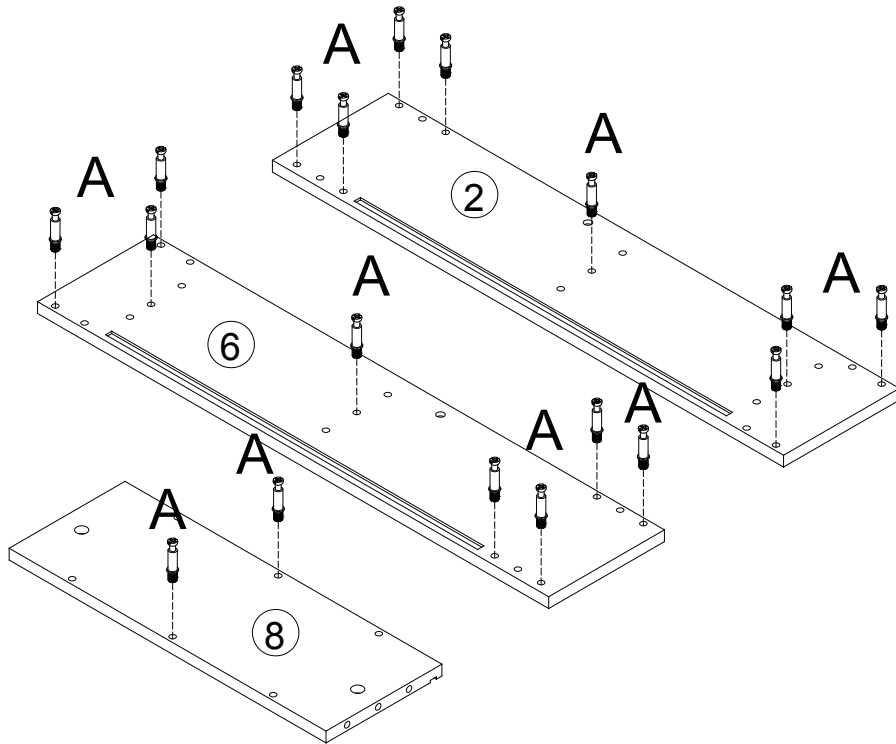

STEP 1

A		18
---	---	----



STEP 2

B		2
C		4

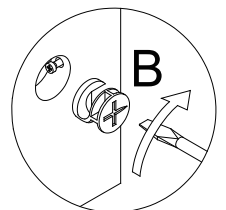
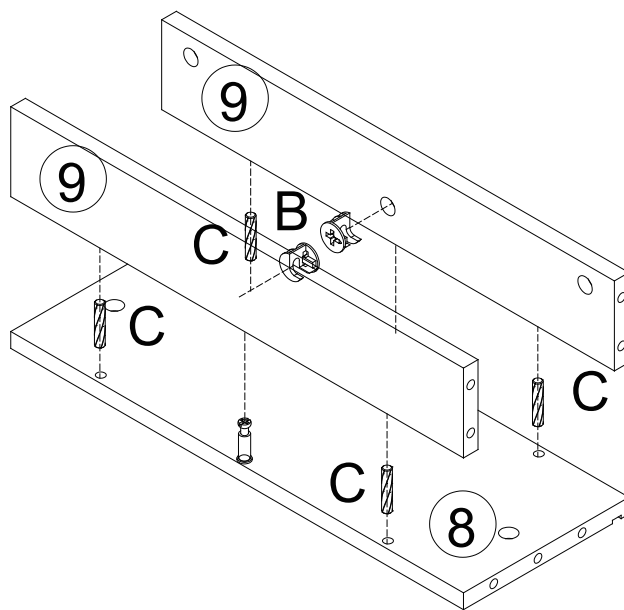

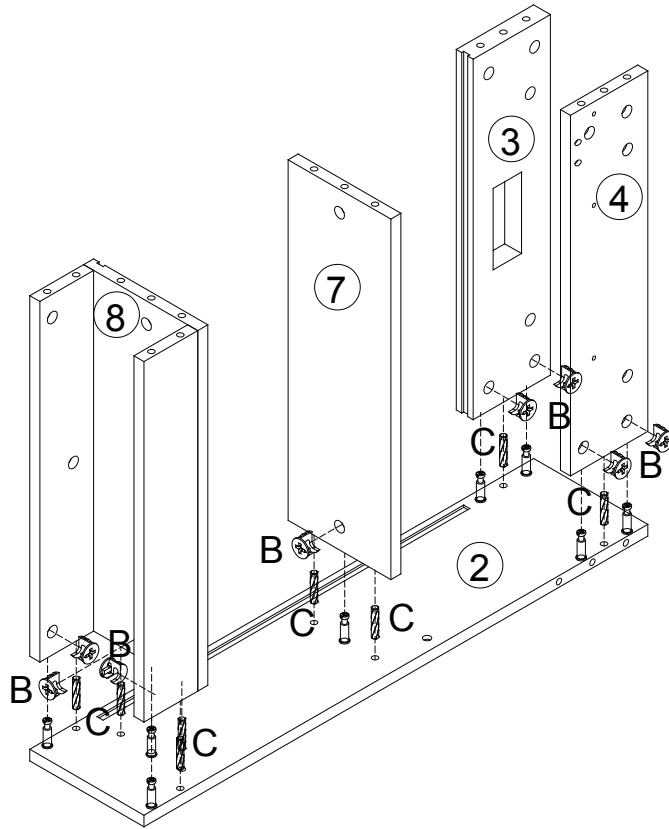

STEP 3

B		8
C		8



STEP 4

B		8
C		8

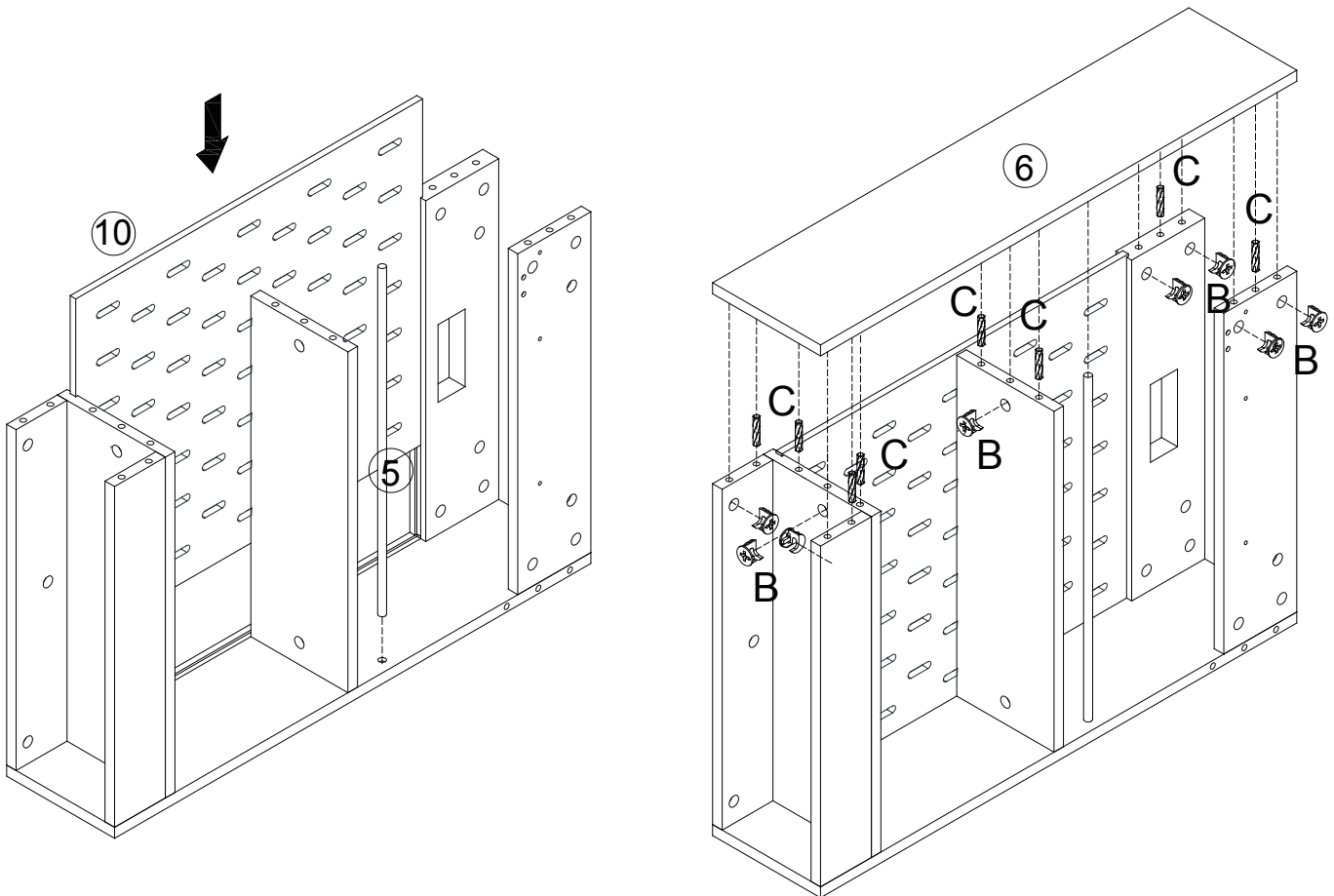

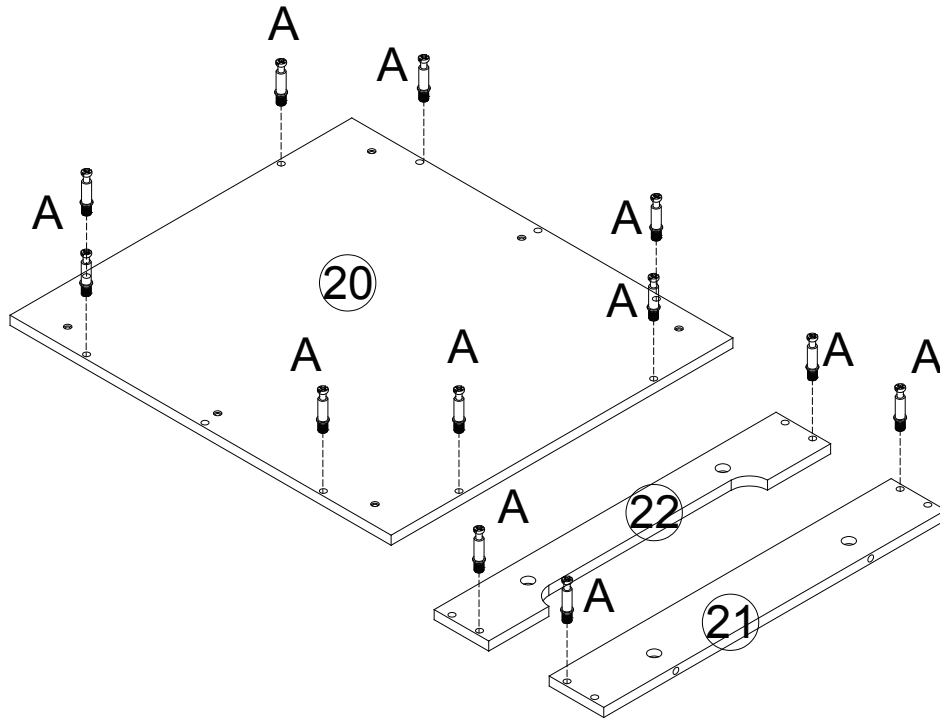

STEP 5

A		12
---	---	----



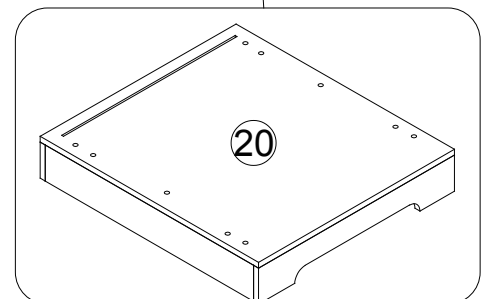
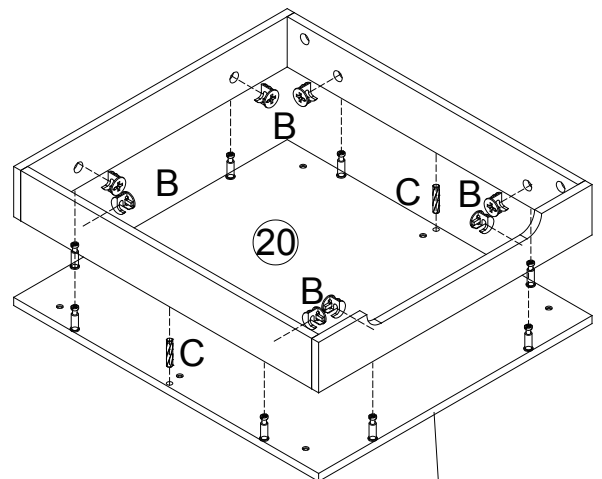
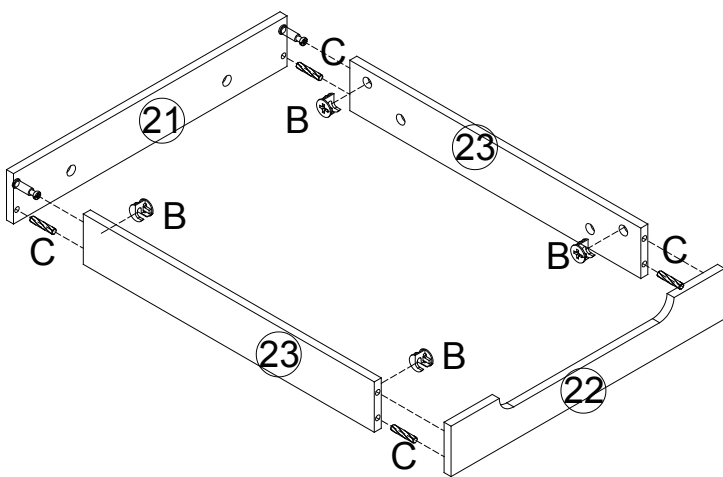

STEP 6

B		12
C		6





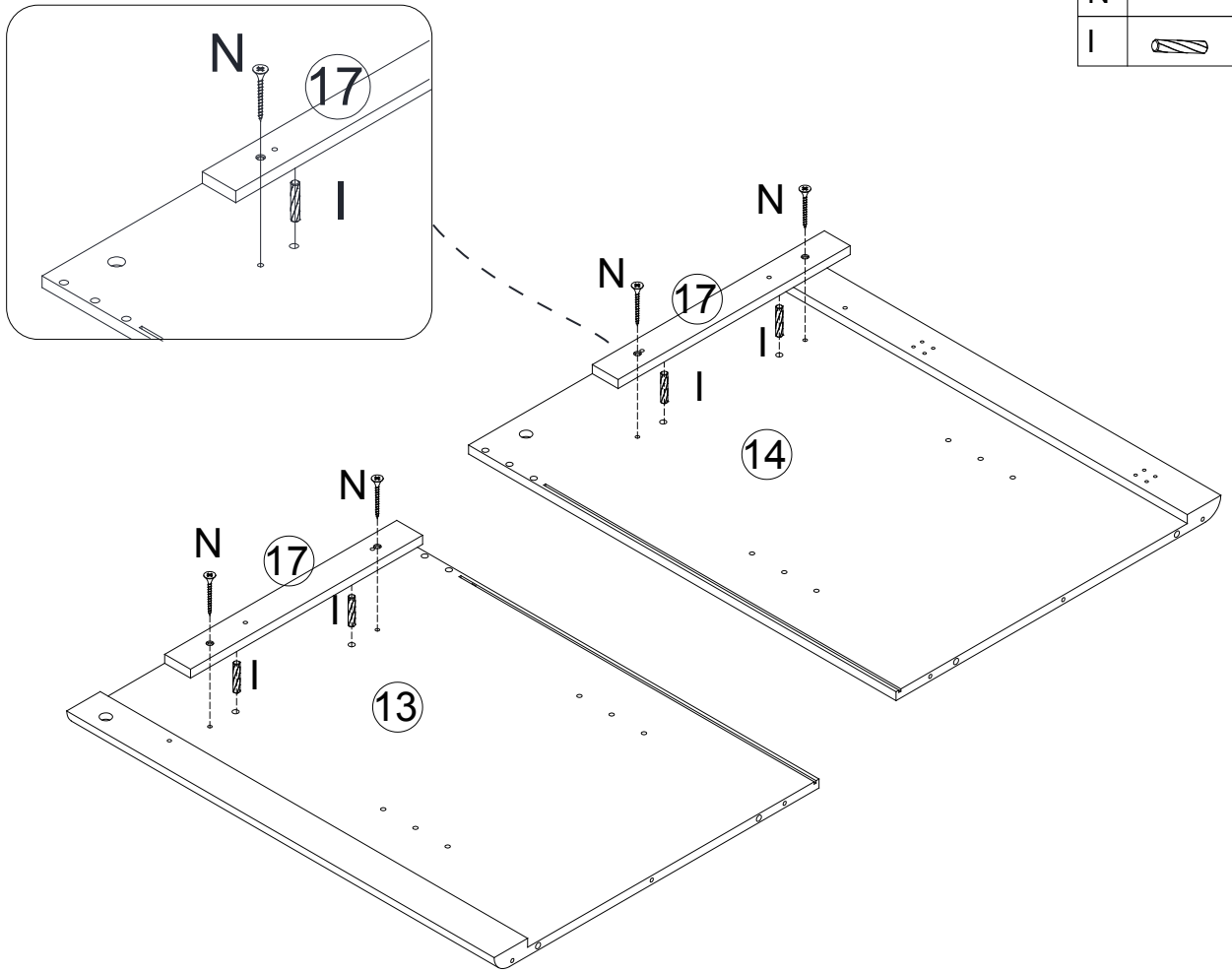

STEP 7

N		4
I		4



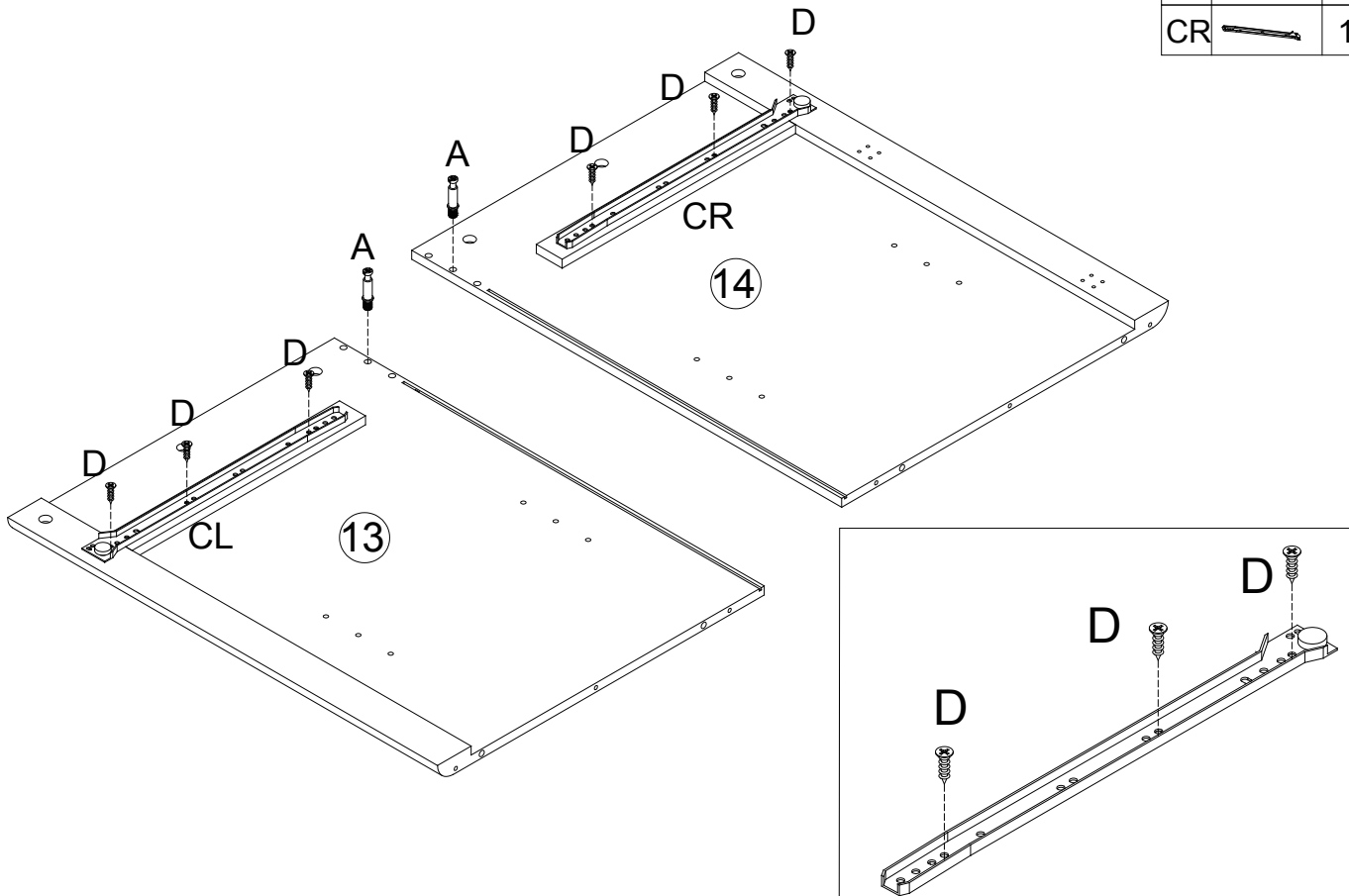

STEP 8

A		2
D		6
CL		1
CR		1



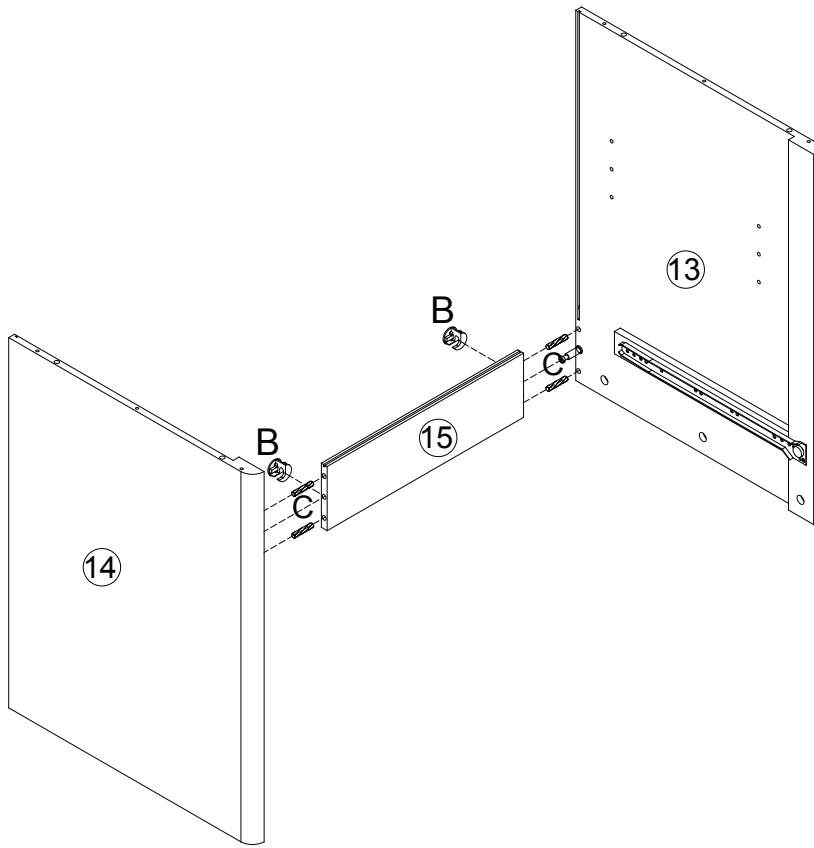

STEP 9

B		2
C		4



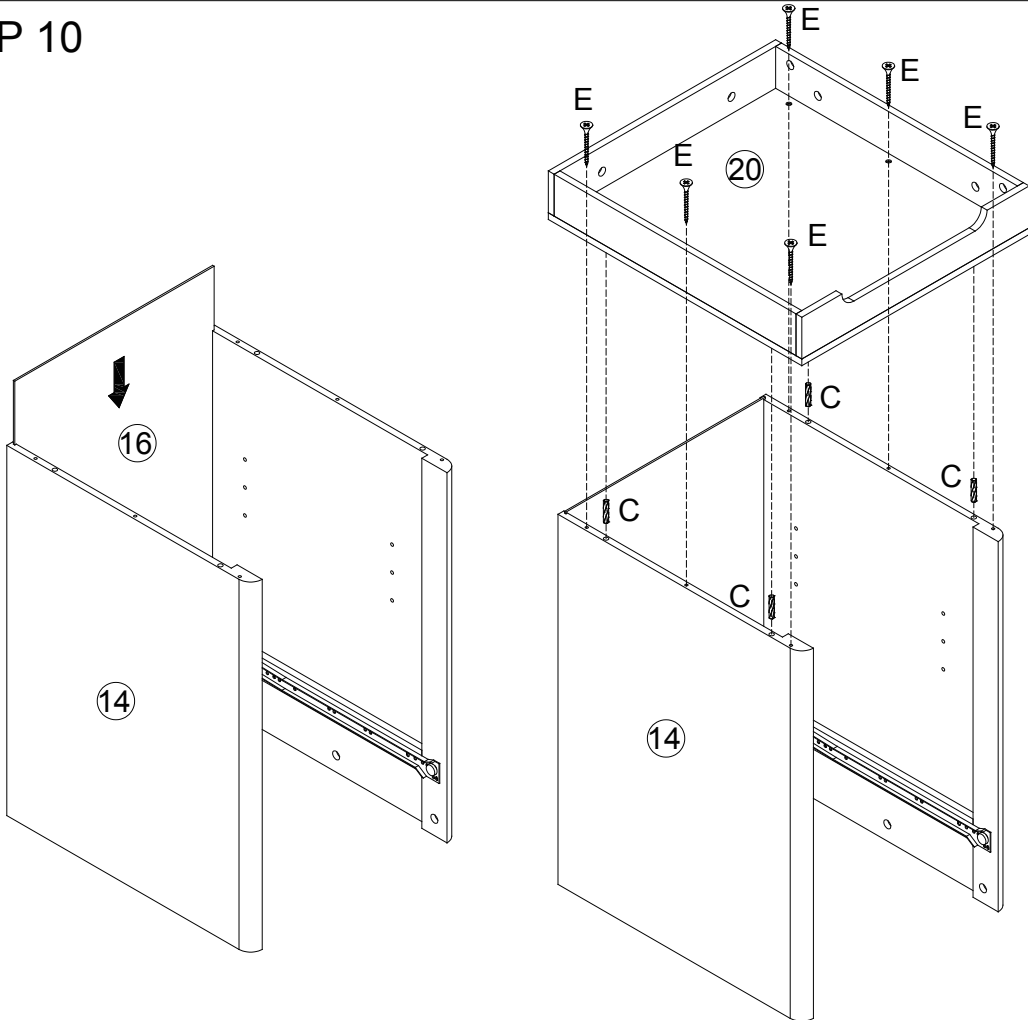

STEP 10

E		6
C		4



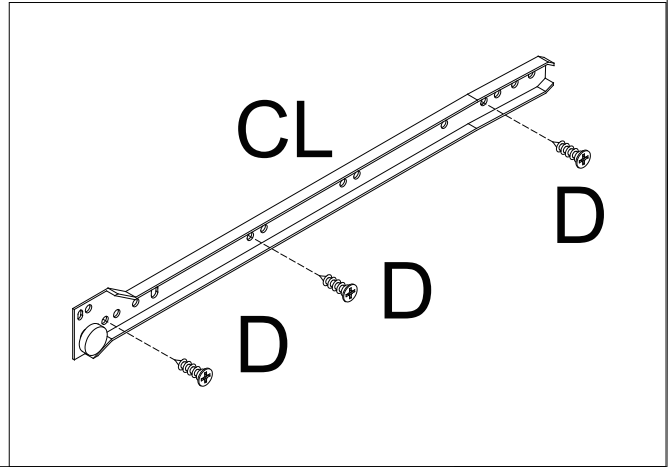
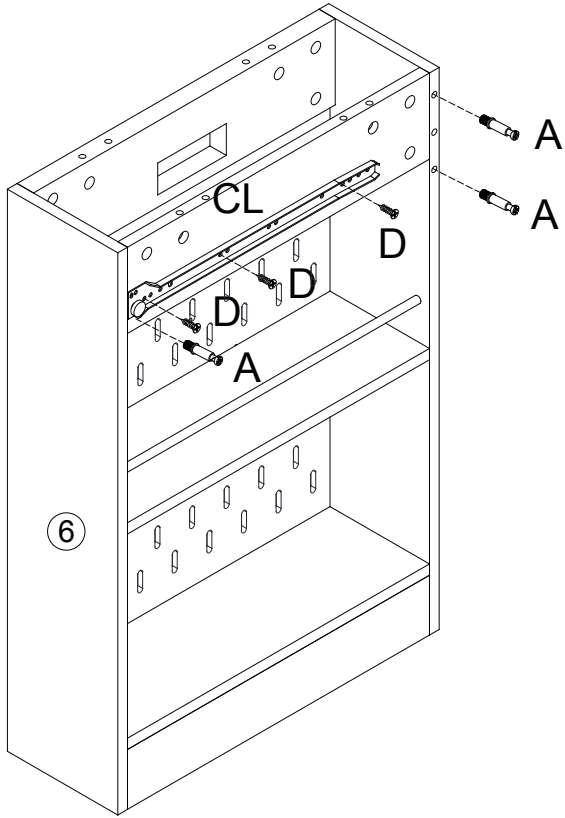

STEP 11

A		3
D		3
CL		1



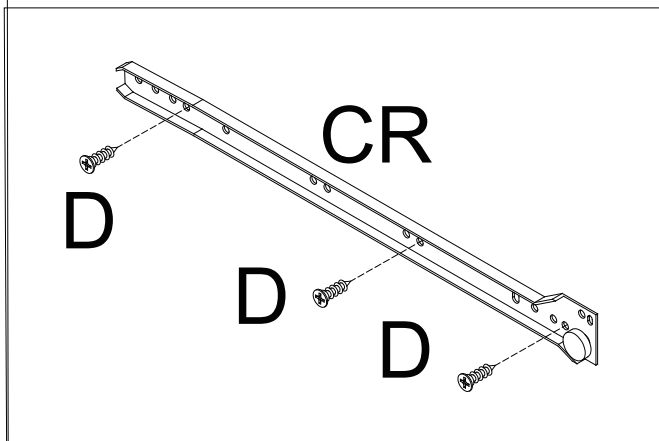
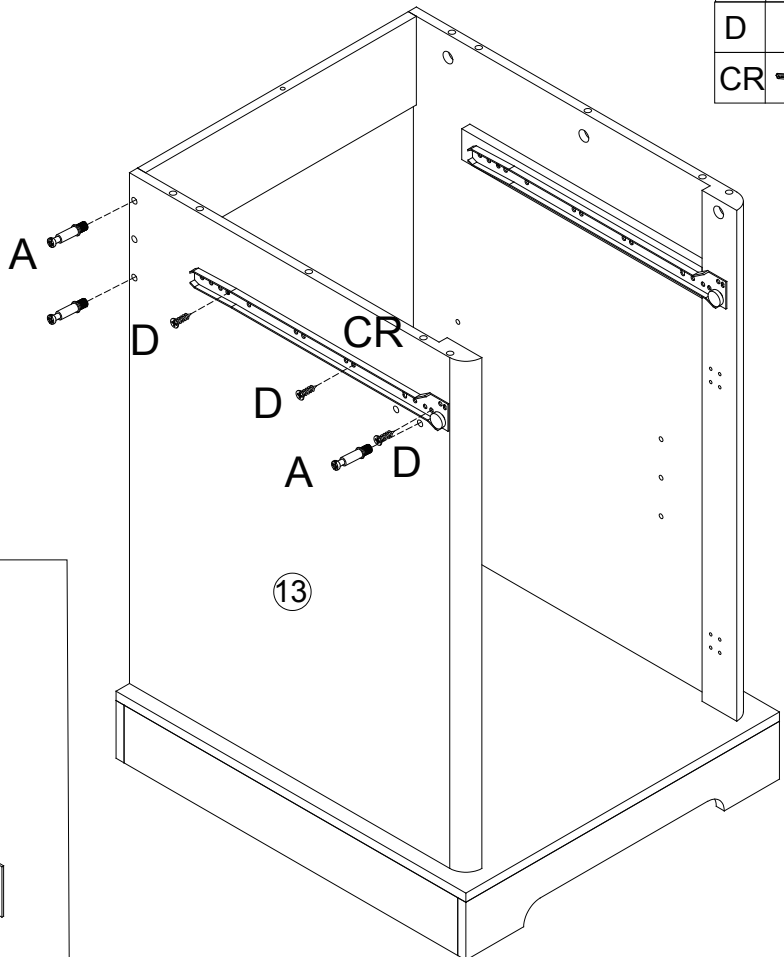

STEP 12

A		3
D		3
CR		1



STEP 13

B		6
C		4

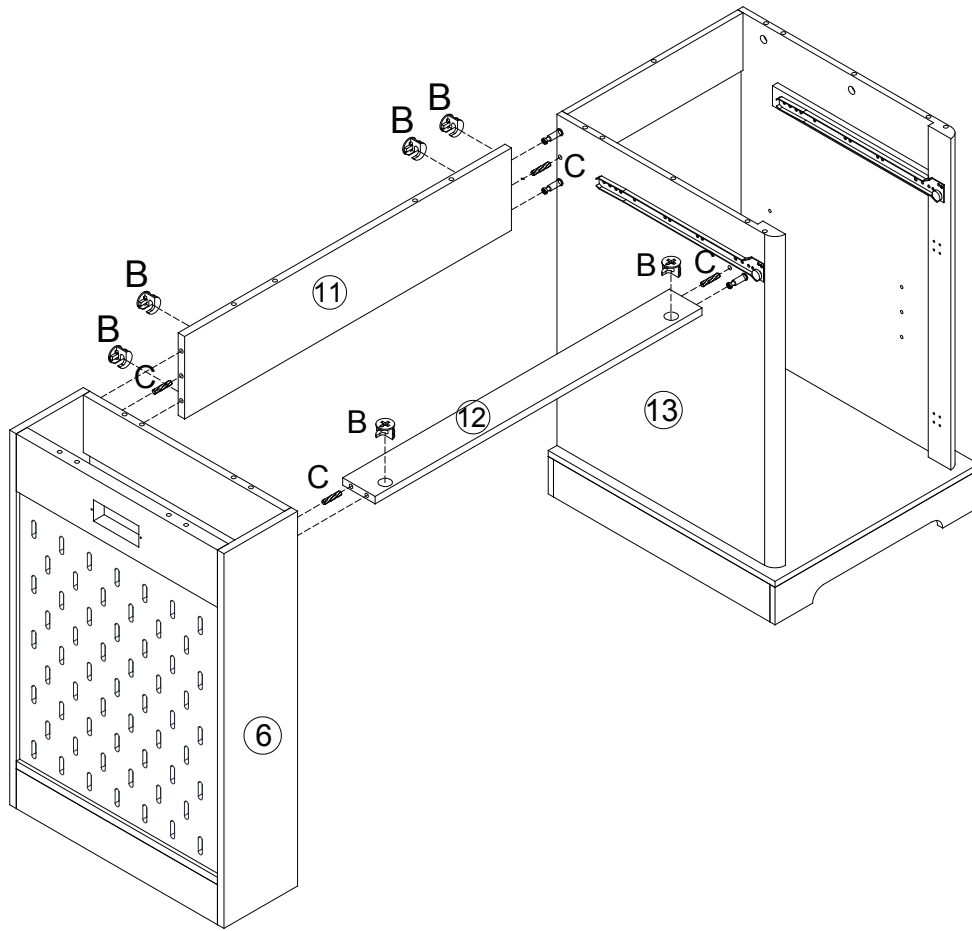

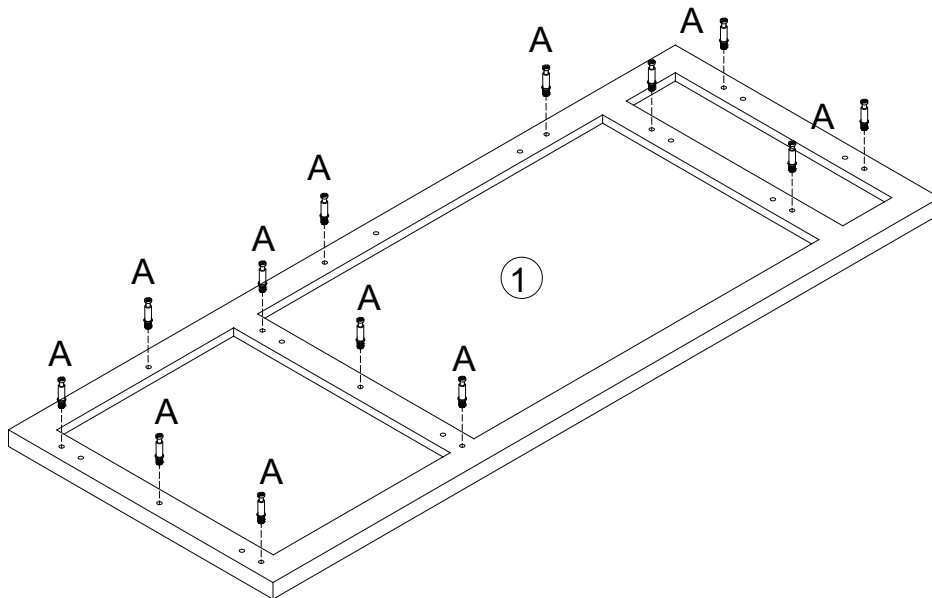

STEP 14

A		13
---	---	----







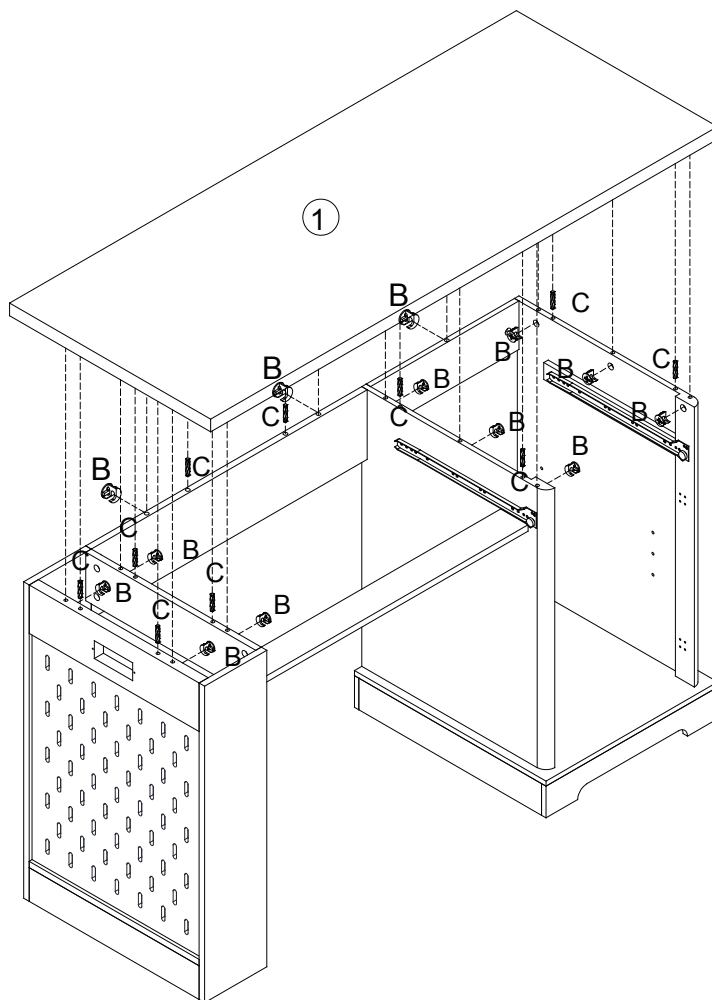



STEP 15

B		13
C		10



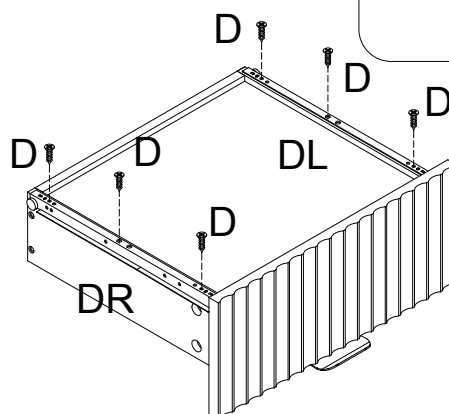
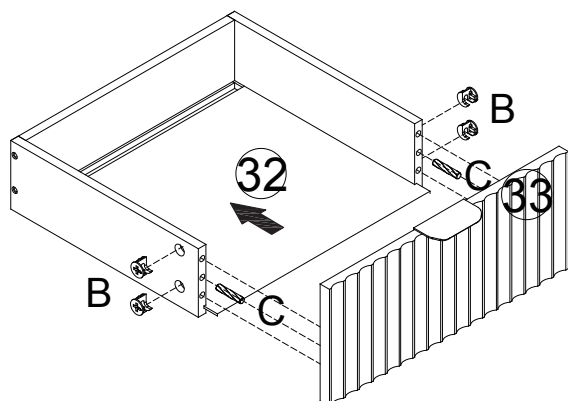
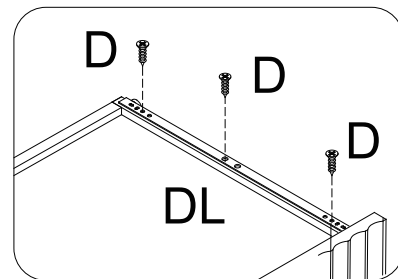
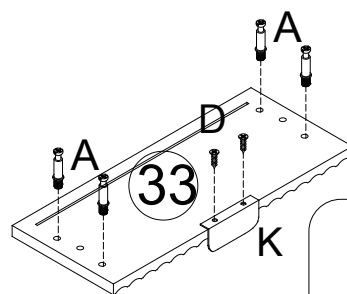
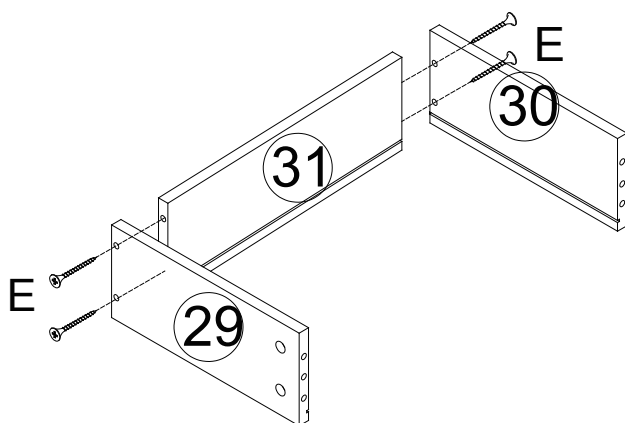

STEP 16

C		2	A		4
K		1	B		4
			D		8
			E		4
			DL		1
			DR		1



STEP 17

L		1
H		2

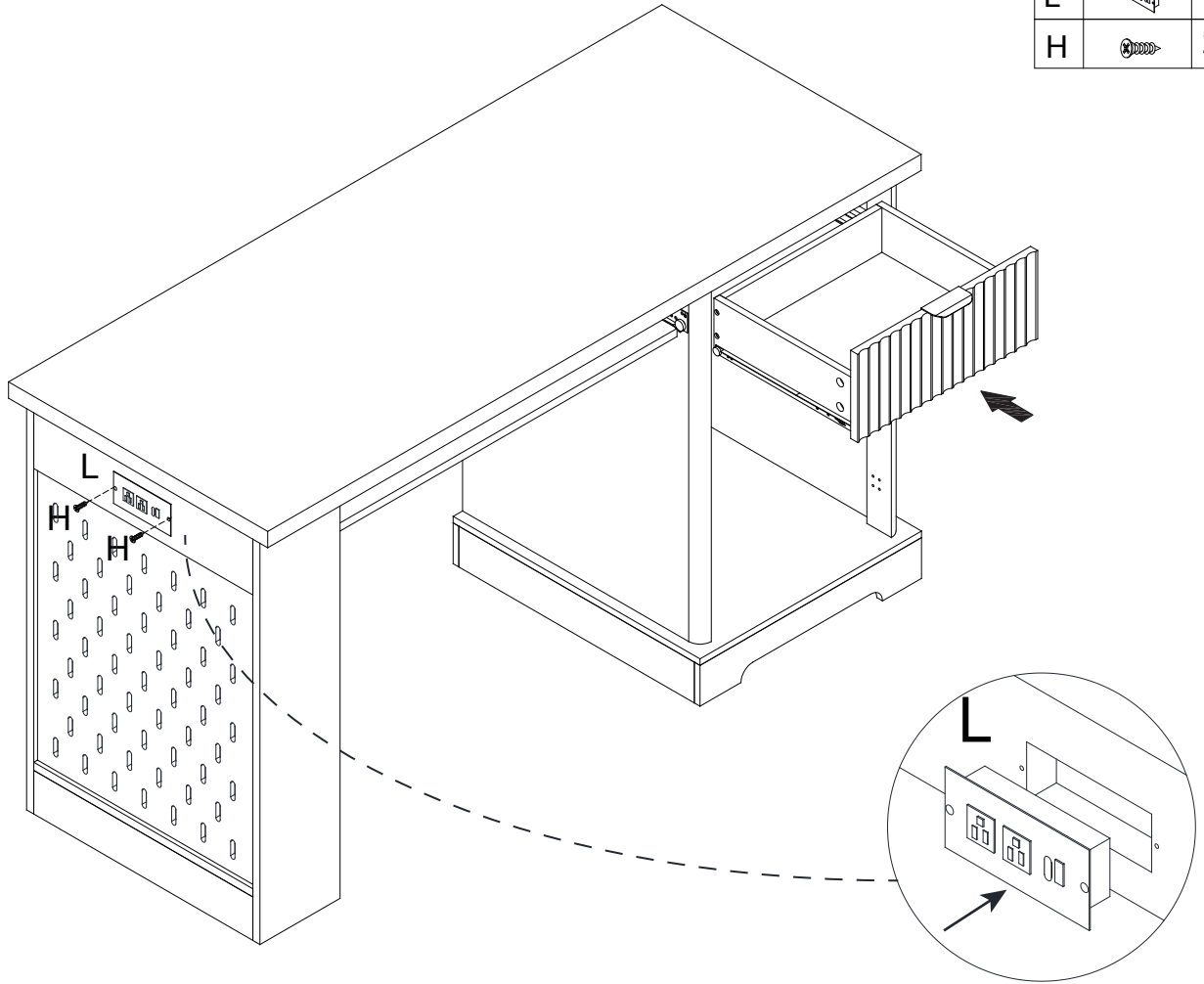



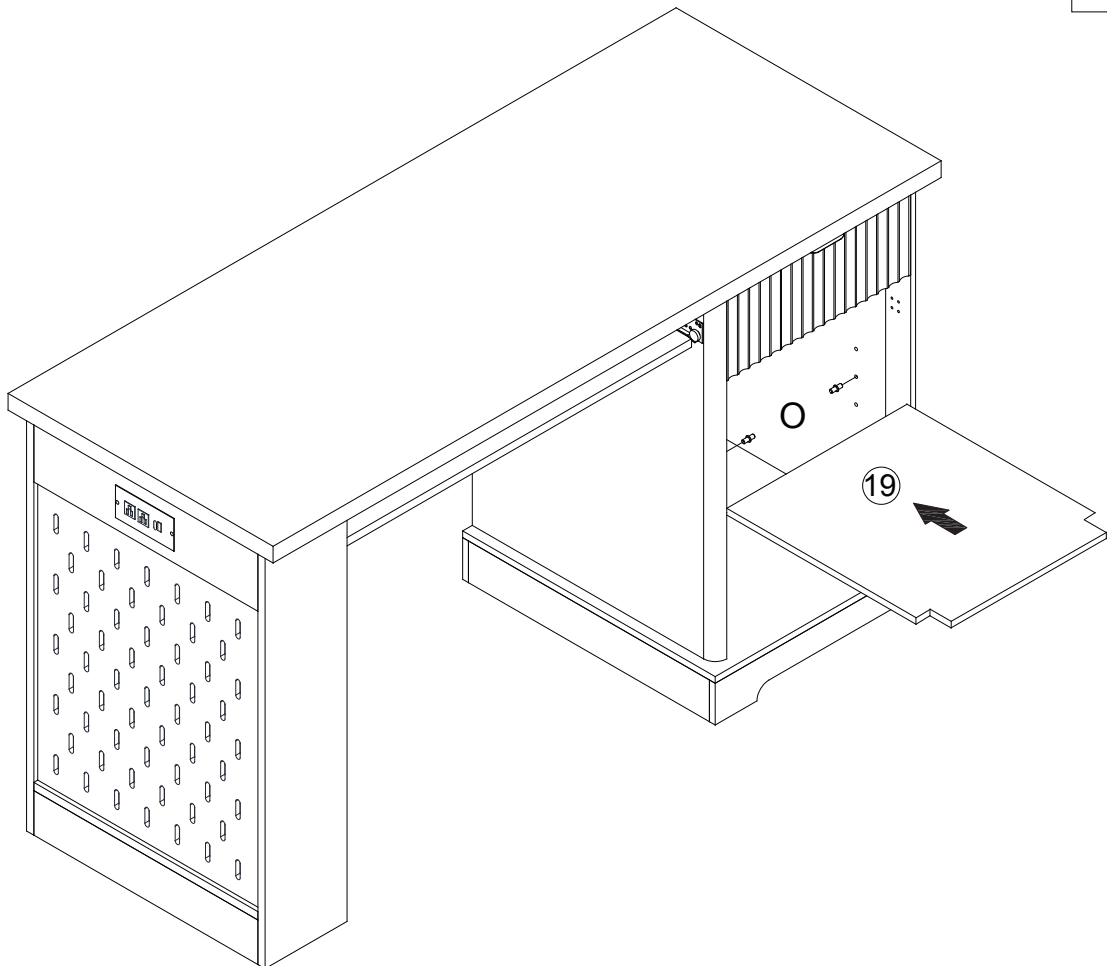

STEP 18

O		4
---	---	---



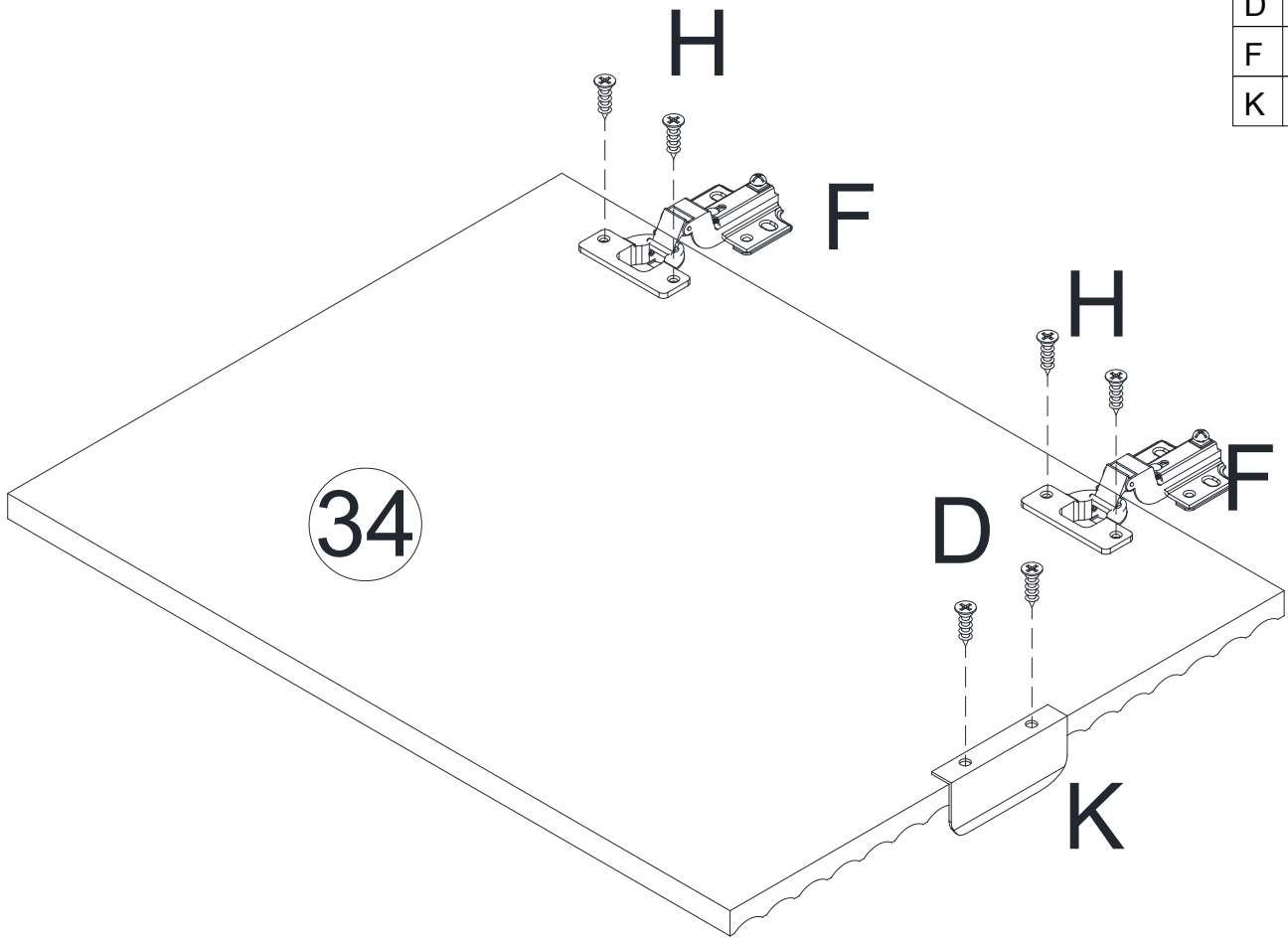

STEP 19

H		4
D		2
F		2
K		1



STEP 20

H		8
R		2

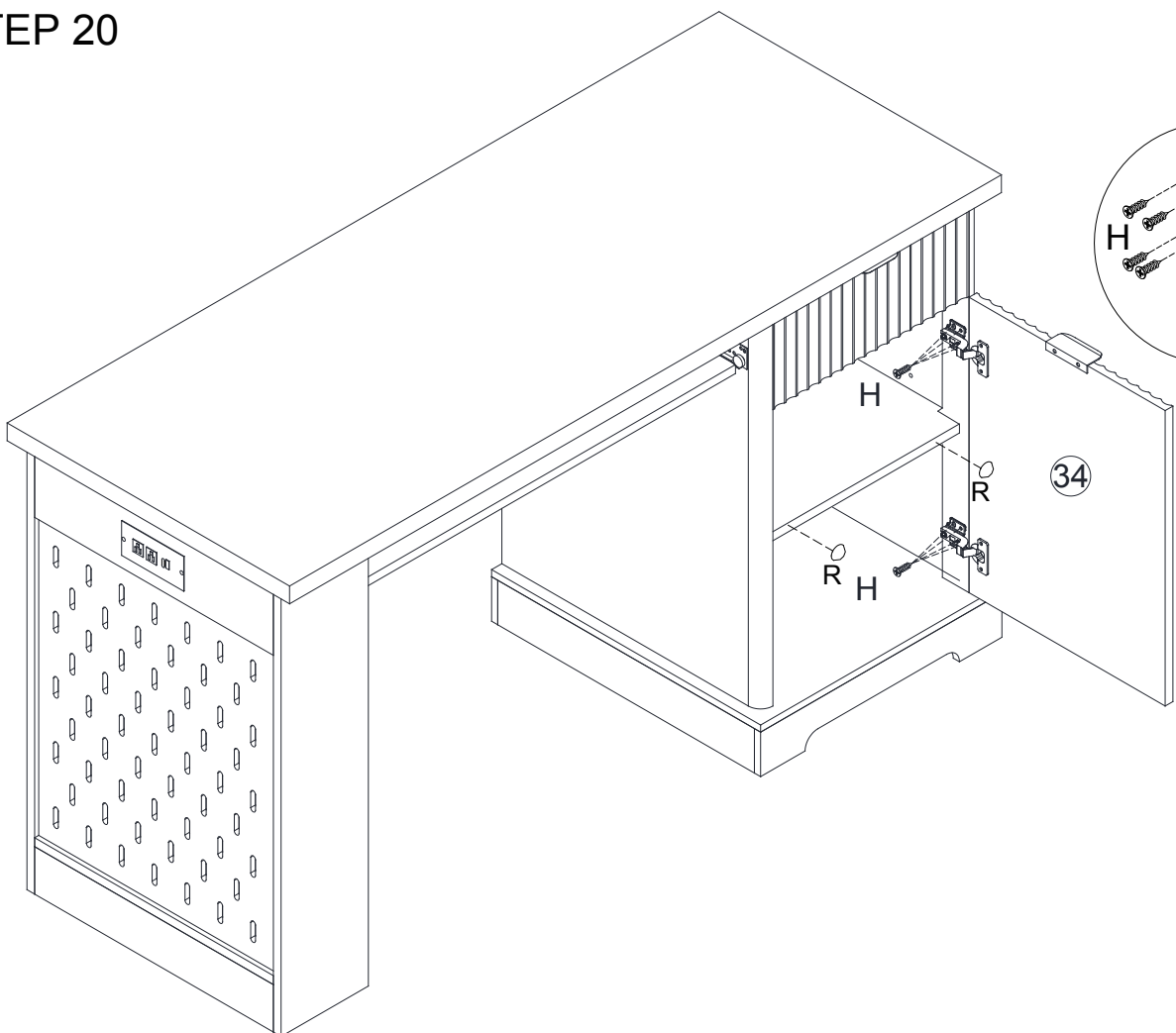





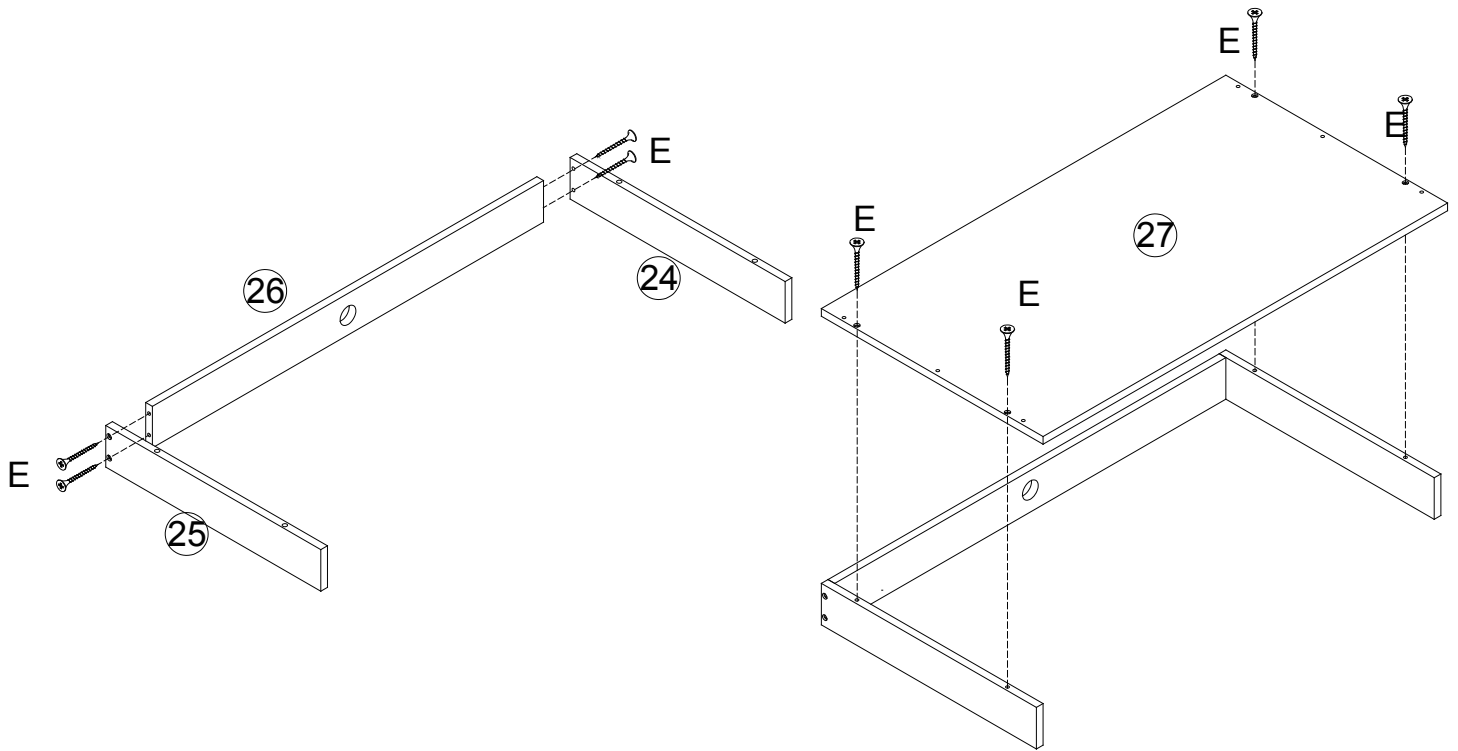

STEP 21

E		8
---	--	---



STEP 22

I		2
G		2
H		8
J		3
DL		1
DR		1
D		6

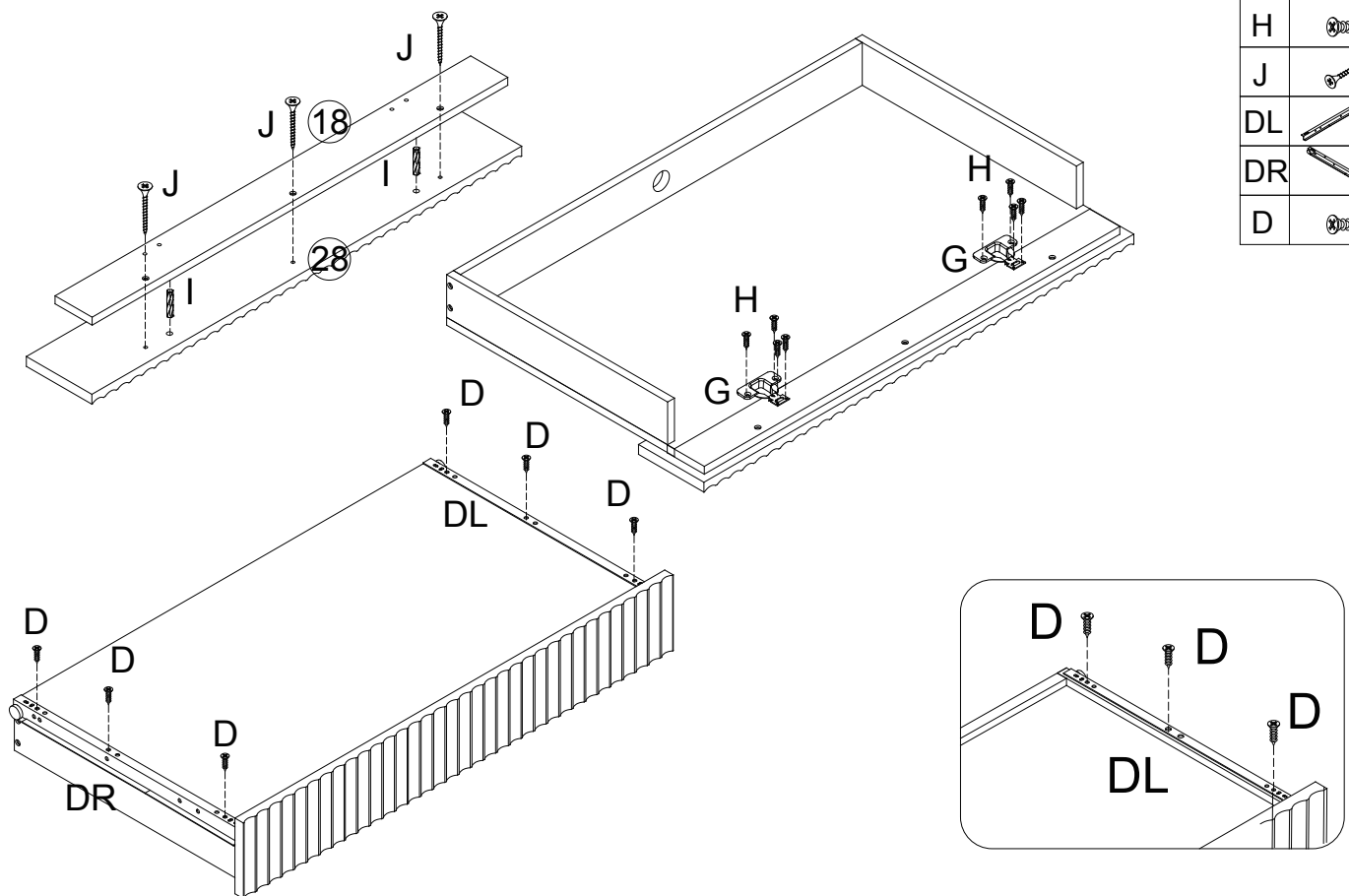

STEP 23

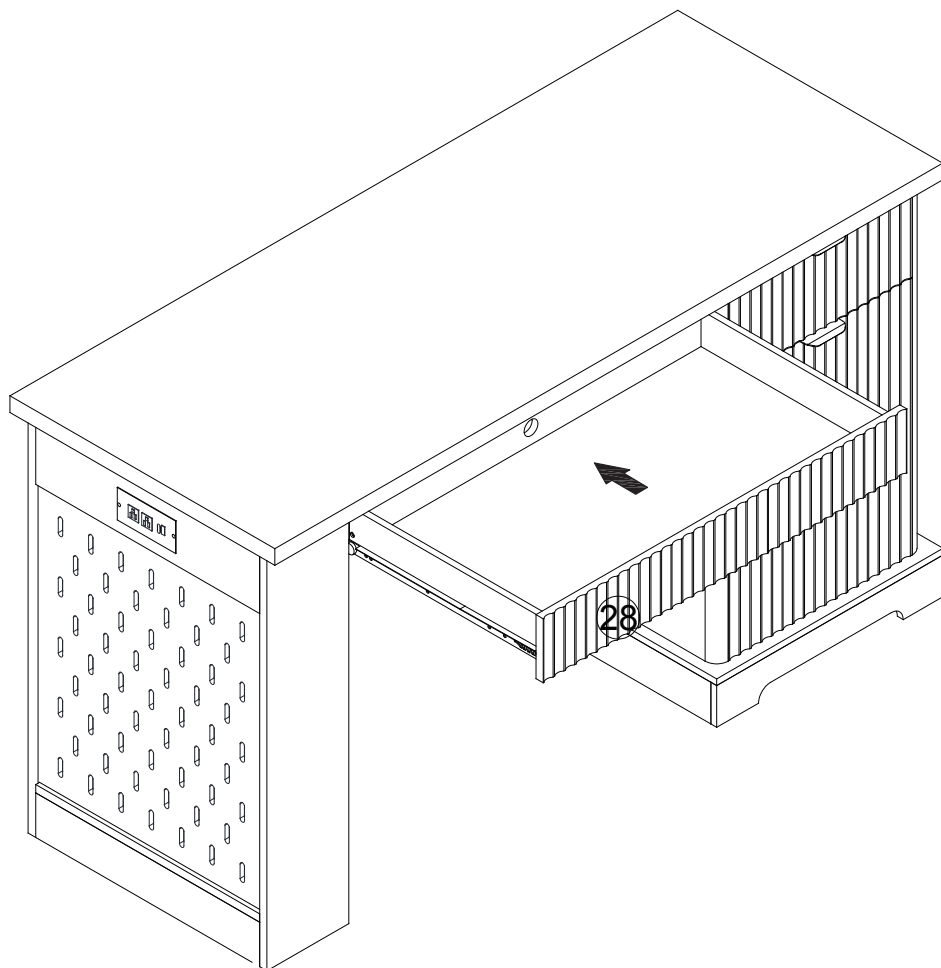

STEP 24

M  3

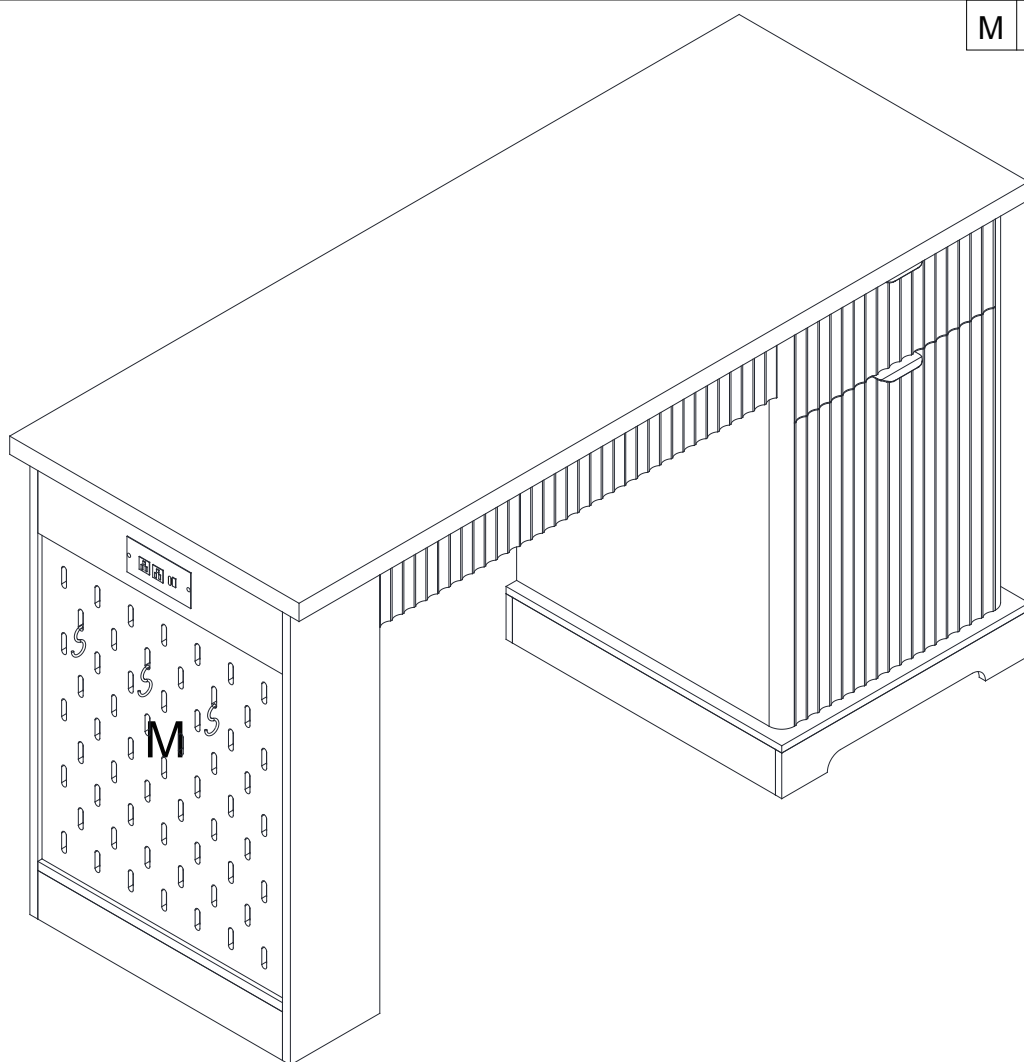

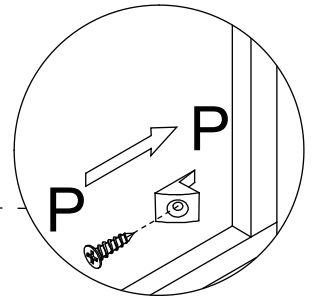
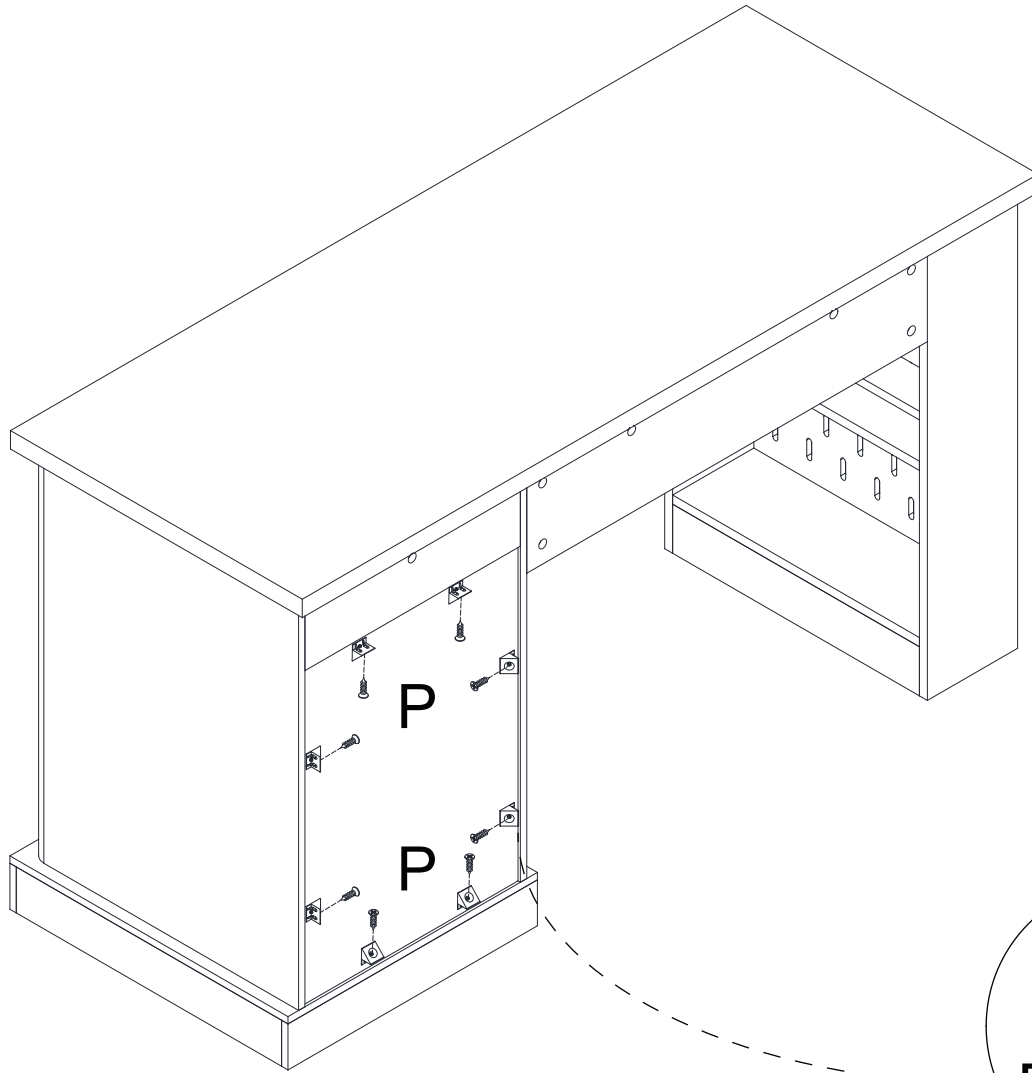

COMPLETE:

