

# ASSEMBLY INSTRUCTIONS

090-1110

## TOOLS REQUIRED:

Allen Wrench (Provided, Part K)  
Screwdriver (Not Provided)

## BEFORE YOU START:

1. Check the hardware against the hardware list to make sure all items are present.
2. Assemble your furniture on a soft, flat surface to avoid scratching the finish.
3. **CAUTION:** Do not over tighten screws, nuts or bolts during assembly.
4. Your furniture may require occasional tightening.

## INSTRUCTIONS:

Step 1. Locate Pneumatic Cylinder(E) on Metal Base(C) and tighten them as Figure 1 shown.

Step 2. Put Cover (F) on Pneumatic Cylinder (E) as Figure 2

Step 3. Place Caster(G) on Metal Base(C) and secure them as Figure 3

Step 4. Place Wood Cap(D) to Metal Base(C).

Step 5. Rest the Wood Cap(D) on top of each leg of the Metal Base (C) and secure them by using Screws(L) as Figure 4 shown.

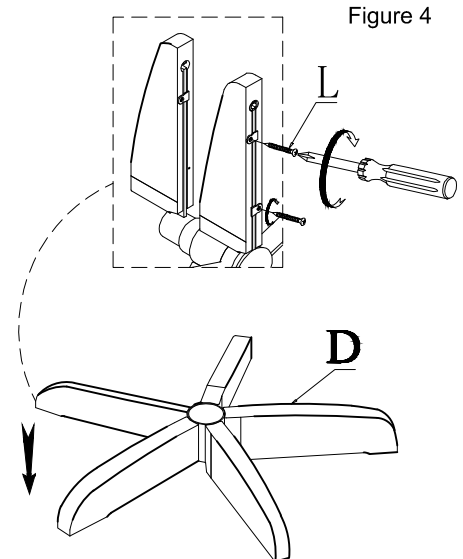
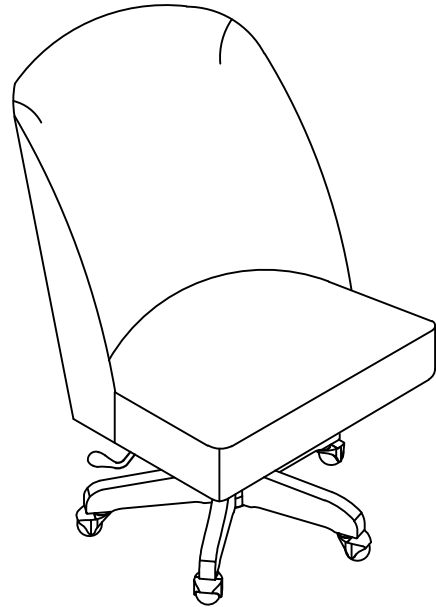

Figure 4

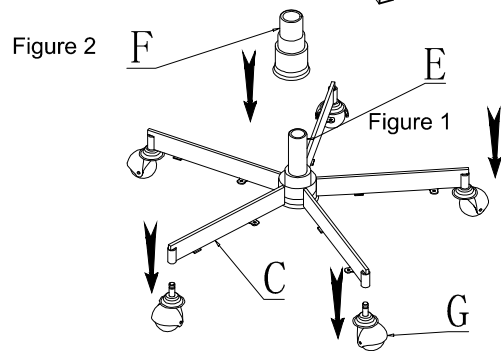

Figure 3

HARDWARE LIST			
A		Seat and Back Assembly	1pc
B		Chair Control Plate	1pc
C		Metal Base	1pc
D		Wood Cap	5pcs
E		Pneumatic Cylinder	1pc
F		Cover	1pc
G		Caster	5pcs
H		Bolt (Ø5/16"x1")	4pcs
I		Lock Washer (Ø5/16")	4pcs
J		Flat Washer (Ø5/16")	4pcs
K		Allen Wrench (100*50*4mm)	1pc
L		Screw (Φ8x1 1/4")	10pcs

# ASSEMBLY INSTRUCTIONS

090-1110

## TOOLS REQUIRED:

Allen Wrench (Provided, Part K)  
Screwdriver (Not Provided)

## BEFORE YOU START:

1. Check the hardwares against the hardware list to make sure all items are present.
2. Assemble your furniture on a soft, flat surface to avoid scratching the finish.
3. **CAUTION:** Do not over tighten screws, nuts or bolts during assembly.
4. Your furniture may require occasional tightening.

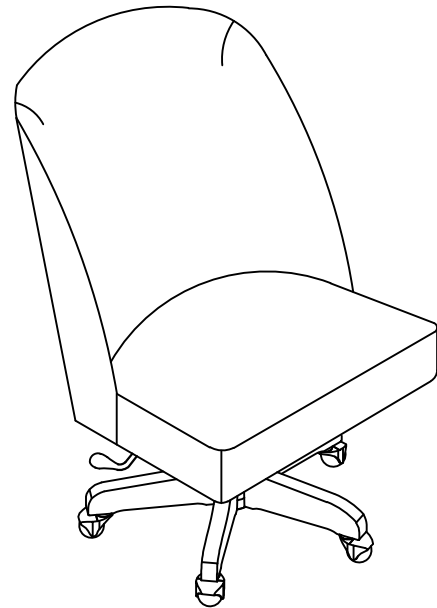

## INSTRUCTIONS:

Step 6. Attach the Chair Control Plate (B) to the Seat and Back Assembly (A) with Flat Washers(J), Lock Washer (I), Bolt (H) as shown. And tighten them by the Allen Wrench (K) as Figure 5 .

Step 7. Attach Pneumatic Cylinder (E) on Chair Control Plate(B), make sure it fitted as Figure 6.

Step 8. Tighten all bolts and assemble successfully as shown in Figure 7.

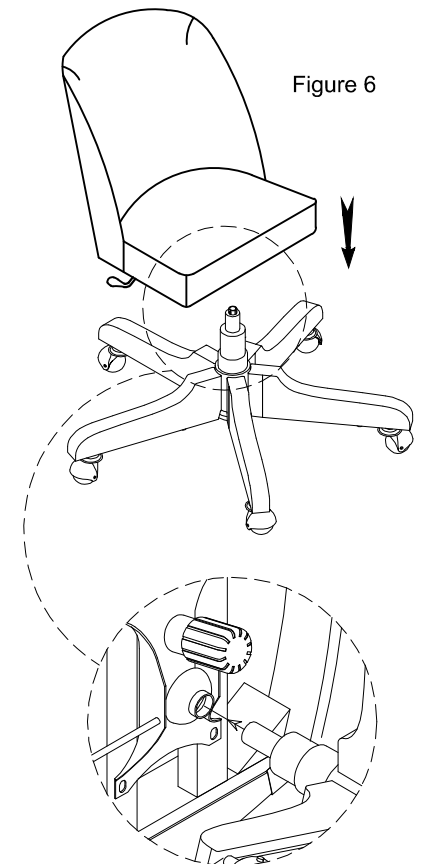
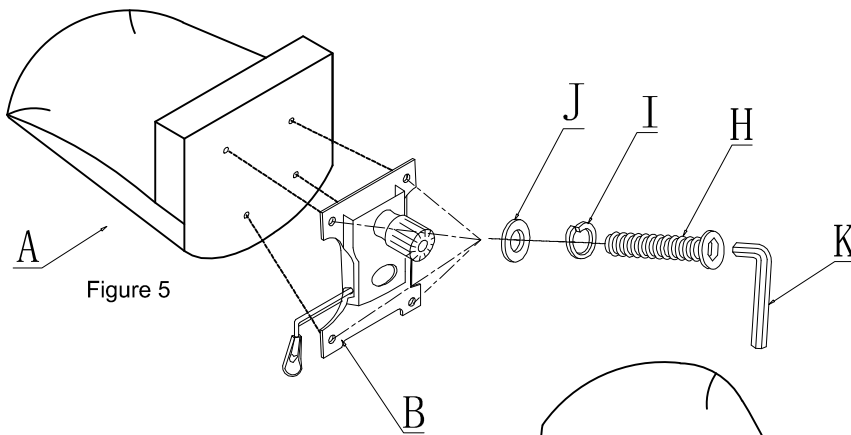

HARDWARE LIST			
A		Seat and Back Assembly	1pc
B		Chair Control Plate	1pc
C		Metal Base	1pc
D		Wood Cap	5pcs
E		Pneumatic Cylinder	1pc
F		Cover	1pc
G		Caster	5pcs
H		Bolt (Ø5/16"x1")	4pcs
I		Lock Washer (Ø5/16")	4pcs
J		Flat Washer (Ø5/16")	4pcs
K		Allen Wrench (100*50*4mm)	1pc
L		Screw (Φ8x1 1/4")	10pcs