

Assembly | Asamblea | Assemblage

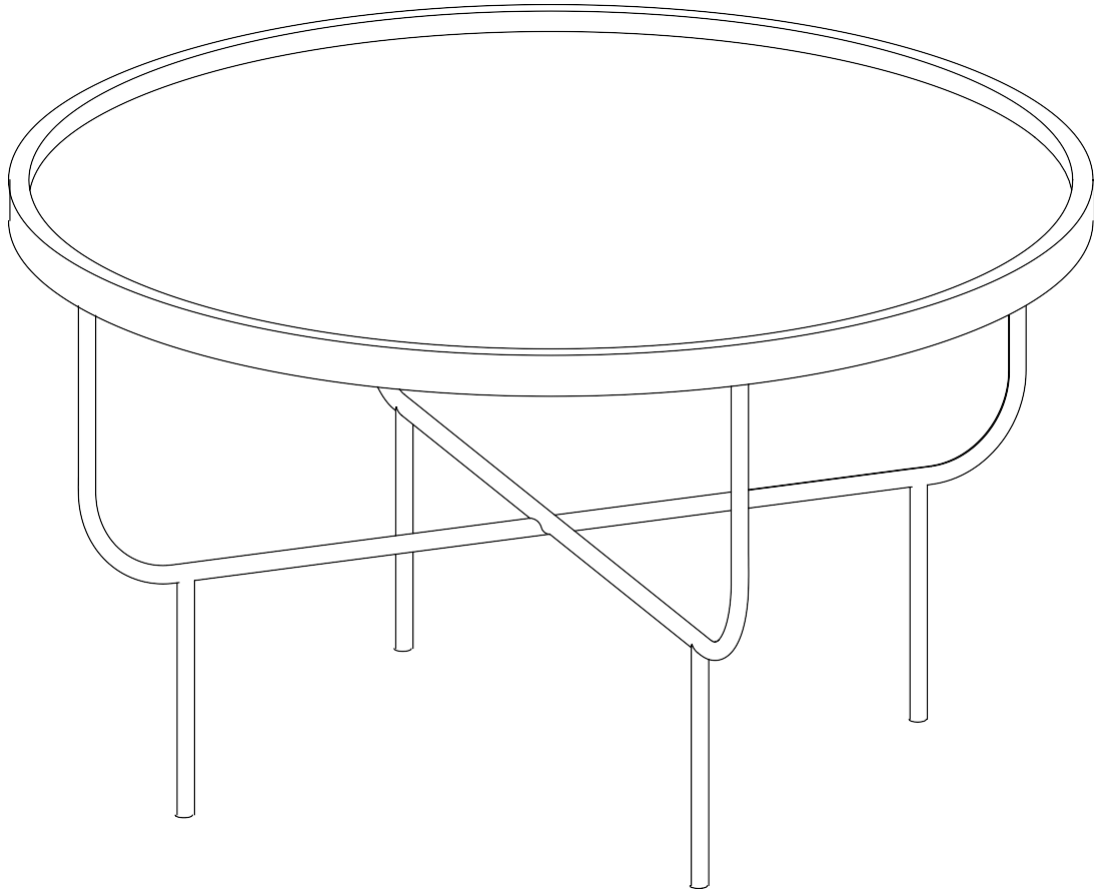

Assembly | Asambla | Assemblage

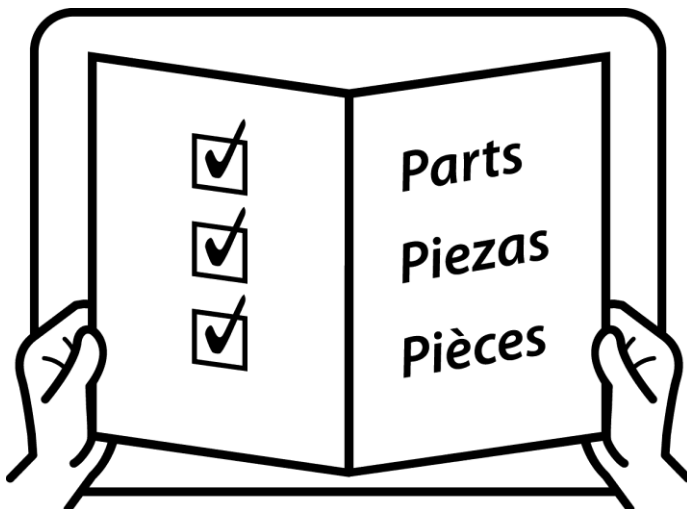
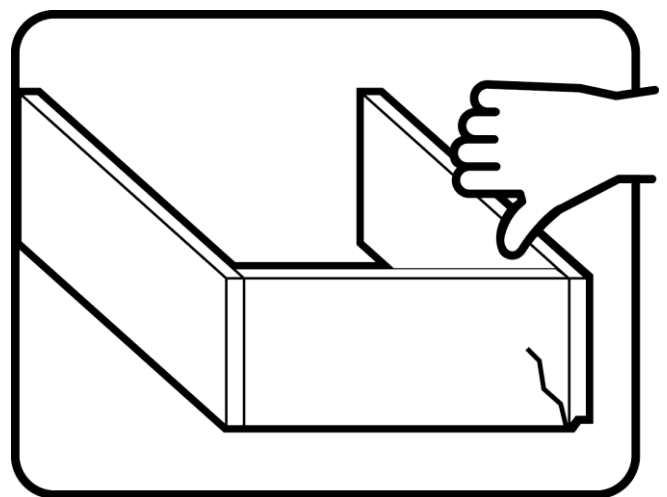
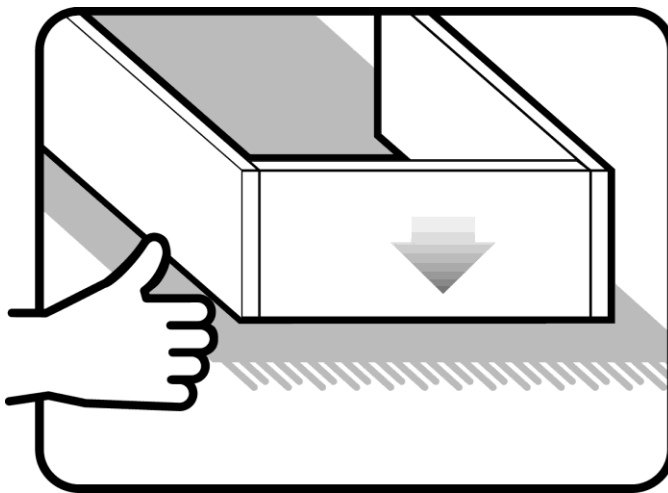
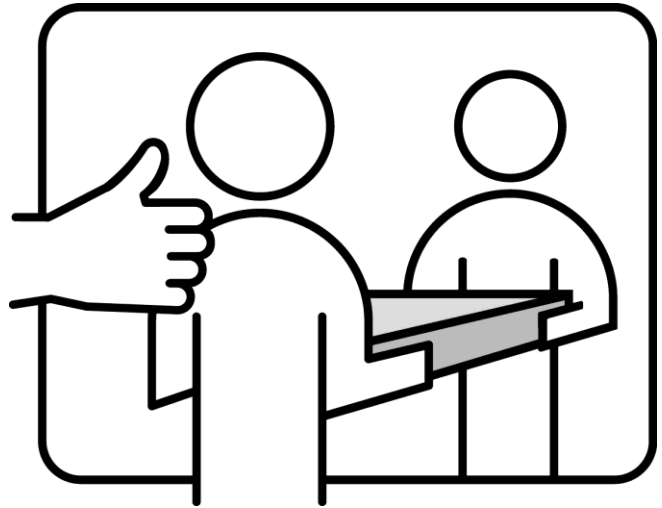
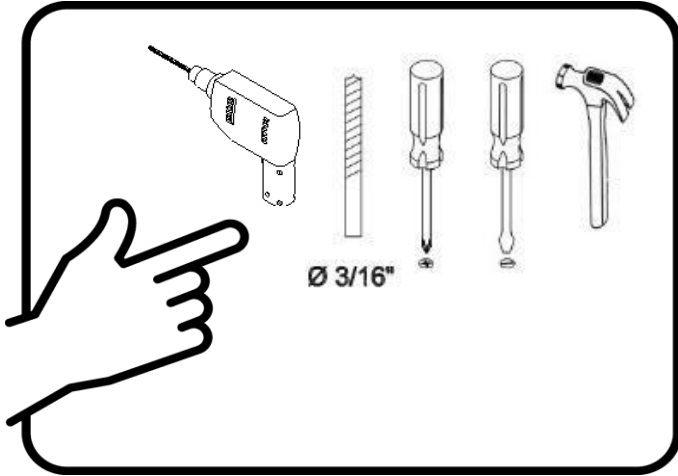

Assembly | Asamblea | Assemblage

Techniques | Técnicas | Techniques

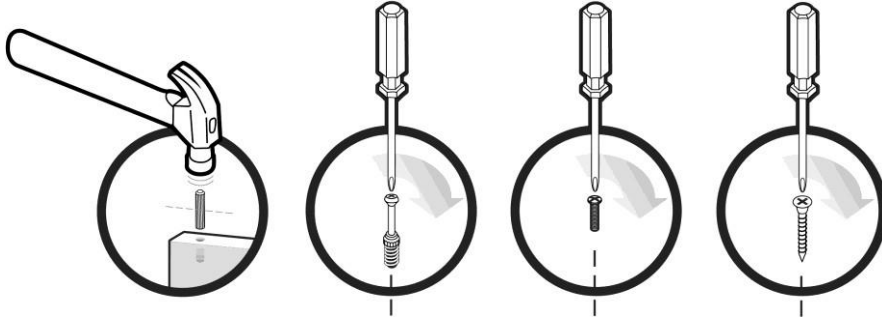

Care | Cuidado | Entretien

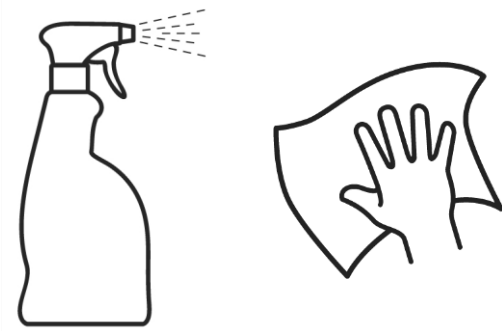

Safety | Seguridad | Sécurité



Note! | ¡Nota! | Remarque!

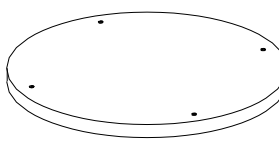
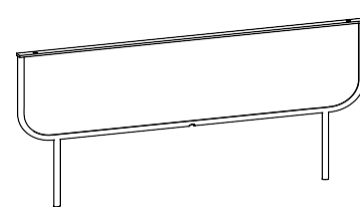
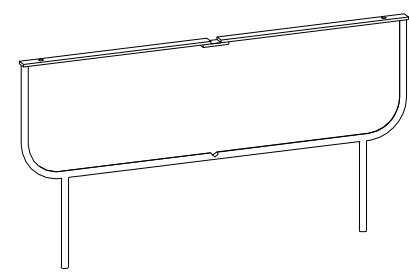

Assembly | Asambllea | Assemblage

<p>A x1</p>  <p>Wooden Top Plateau en bois Tapa de madera</p>	<p>B x1</p>  <p>Leg 1 Jambe 1 Pierna 1</p>	<p>C x1</p>  <p>Leg 2 Jambe 2 Pierna 2</p>
--	---	---

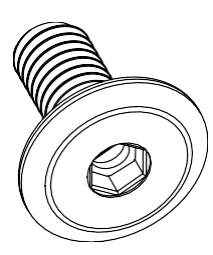
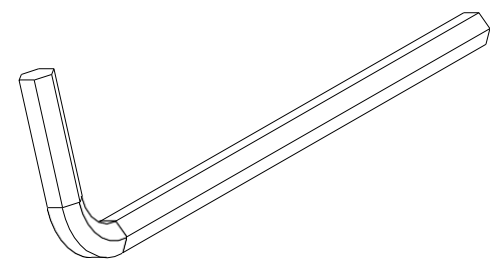
<p>1 x4</p>  <p>Screw Tornillo Vis</p>	<p>2 x1</p>  <p>Allen key Cle Allen Llave allen</p>
--	--

Assembly | Asambllea | Assemblage

STEP 1:

Attach the iron leg 1 to the top (A) using screws as shown in the picture.

PASO 1:

Fije la pata de hierro 1 a la parte superior (A) con tornillos como se muestra en la imagen.

ÉTAPE 1:

Fixez le pied en fer 1 sur le dessus (A) à l'aide de vis comme indiqué sur l'image.

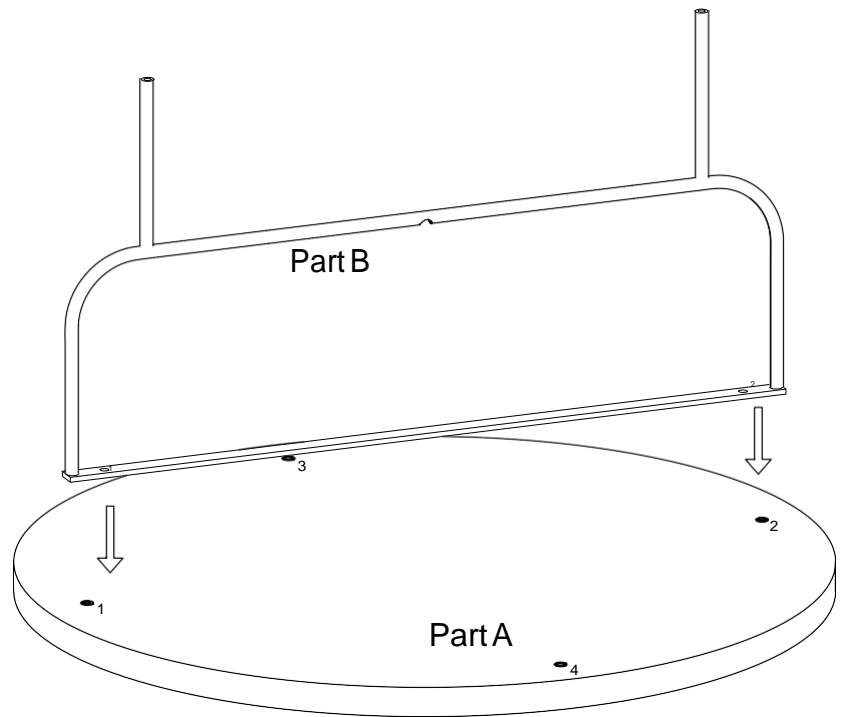

Place the wooden top upside down (on a protective mat).

Coloque la tapa de madera boca abajo (sobre una alfombra protectora).

Placez le plateau en bois à l'envers (sur un tapis de protection).

STEP 2:

Tighten the screws using the Allen key.

PASO 2:

Apriete los tornillos con la llave Allen.

ÉTAPE 2:

Serrez les vis à l'aide de la clé Allen.

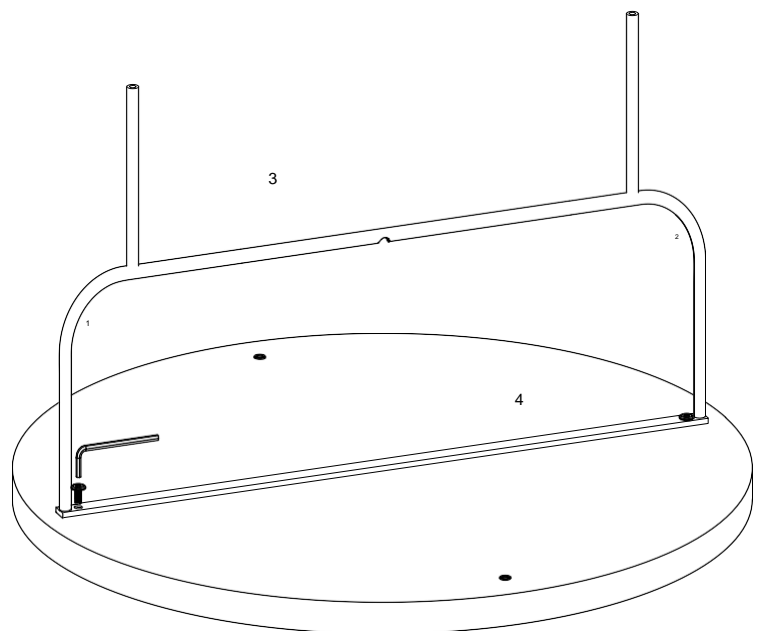

Assembly | Asamlea | Assemblage

STEP 3:

Turn leg 2 horizontally and insert under leg 1.

PASO 3:

Gire la pierna 2 horizontalmente e insértela debajo de la pierna 1.

ÉTAPE 3:

Tournez le pied 2 horizontalement et insérez-le sous le pied 1.

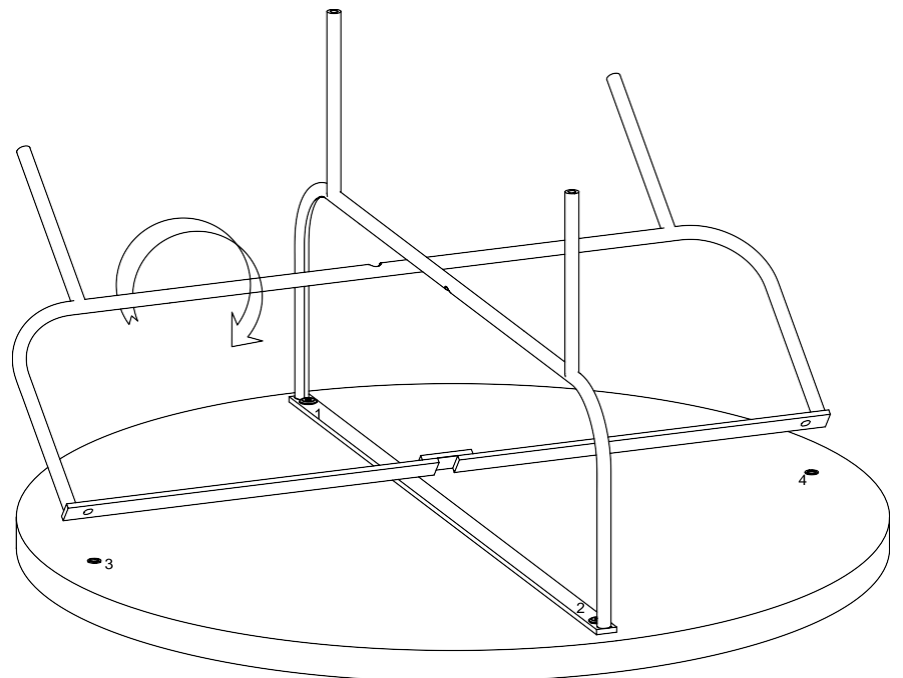
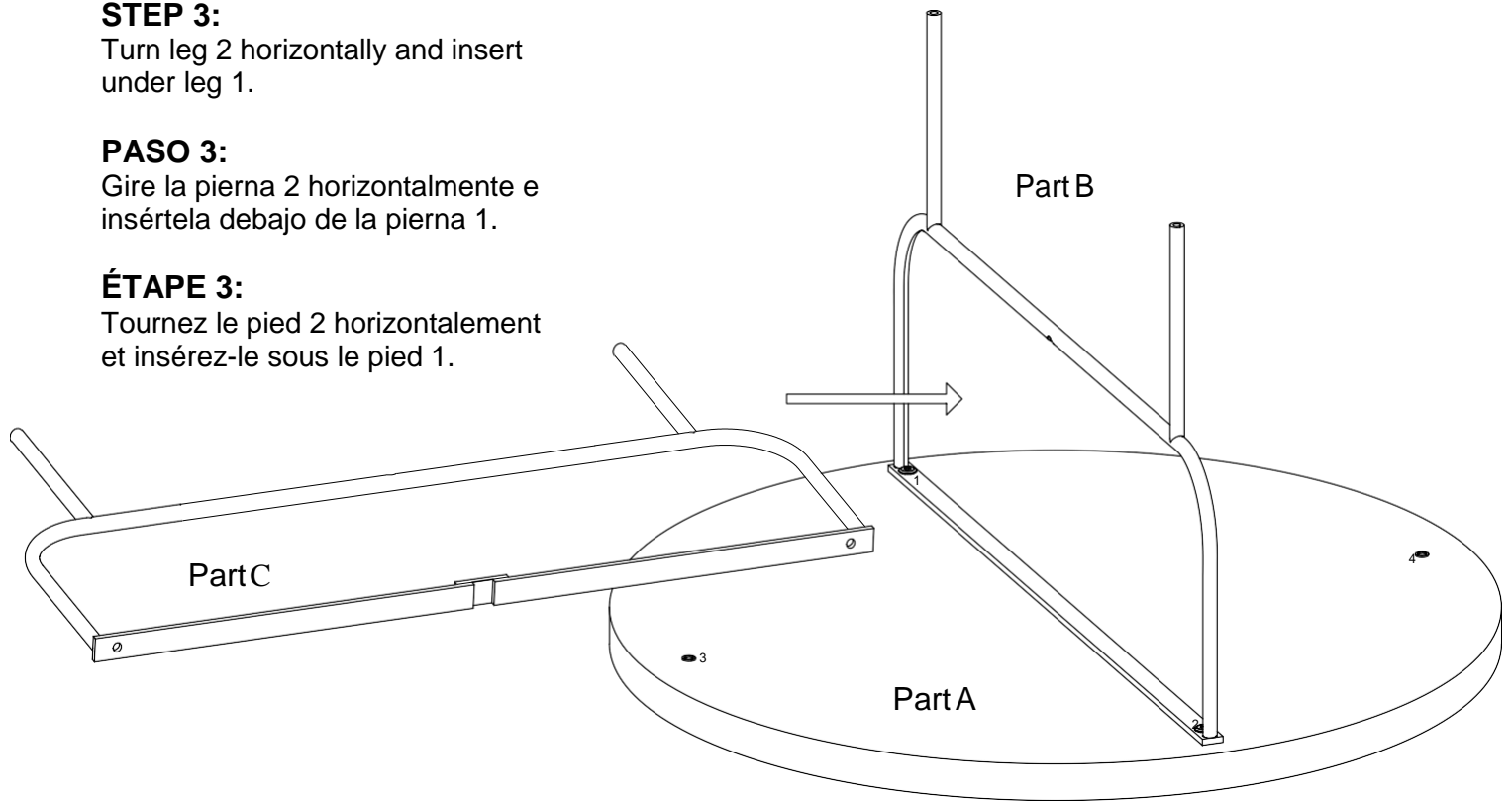

Overturn leg 2 carefully.

Voltee la pata 2 con cuidado.

Retournez la jambe 2 avec précaution.

Assembly | Asambla | Assemblage

STEP 4:

Tighten the screws again using the Allen key.

PASO 4:

Vuelva a apretar los tornillos con la llave Allen.

ÉTAPE 4:

Resserrez les vis à l'aide de la clé Allen.

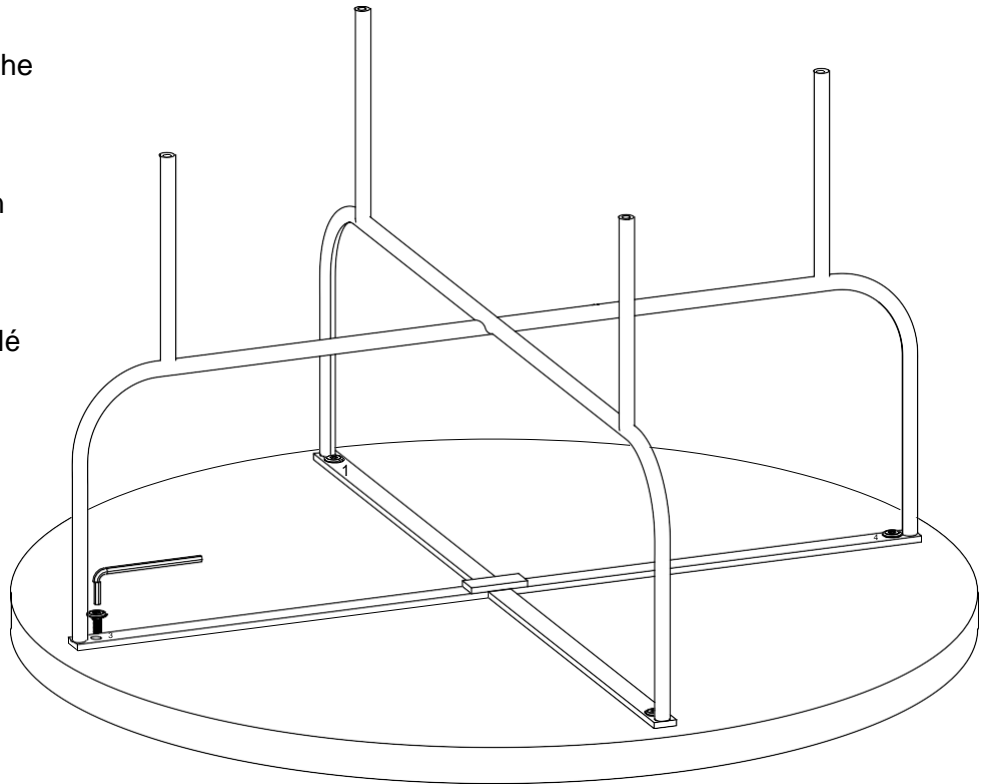

After attaching both legs, make sure they are fixed firmly and not shaking.

Después de sujetar ambas piernas, asegúrese de que estén bien fijadas y no tiemblen.

Après avoir attaché les deux jambes, assurez-vous qu'elles sont bien fixées et qu'elles ne tremblent pas.

Overturn the table carefully.

Voltee la mesa con cuidado.

Retournez la table avec précaution.

