

'XX' REPRESENTS HARDWARE FINISH CODE

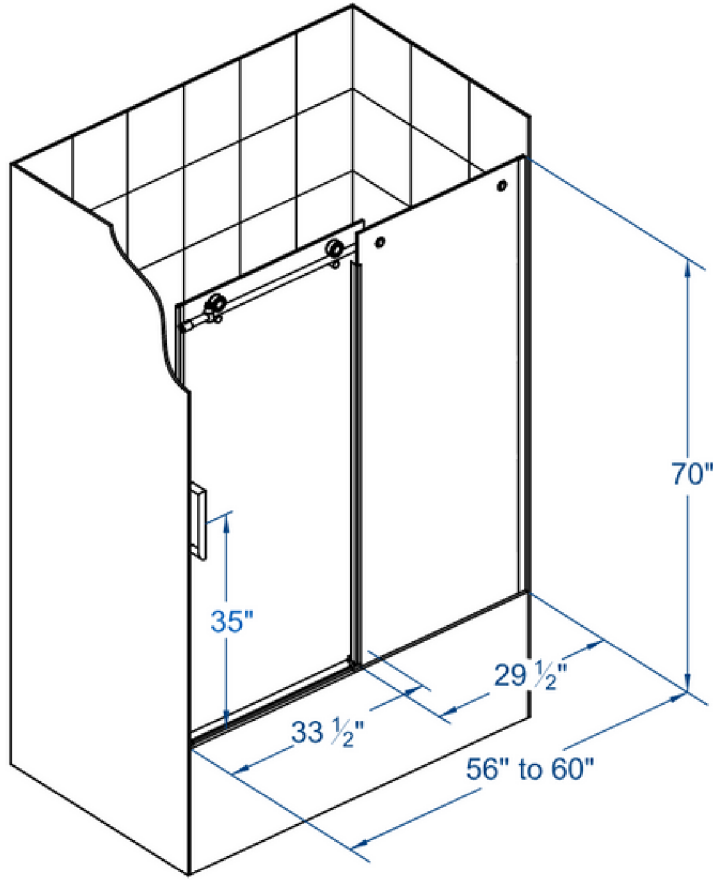

CLEAR GLASS WITH **STARCAST**
BY **ENDUROSHIELD** COATING



LANGHAM XL CLEAR GLASS MODELS INCLUDE PROFESSIONALLY APPLIED:

STARCAST
FROM **EnduroShield**

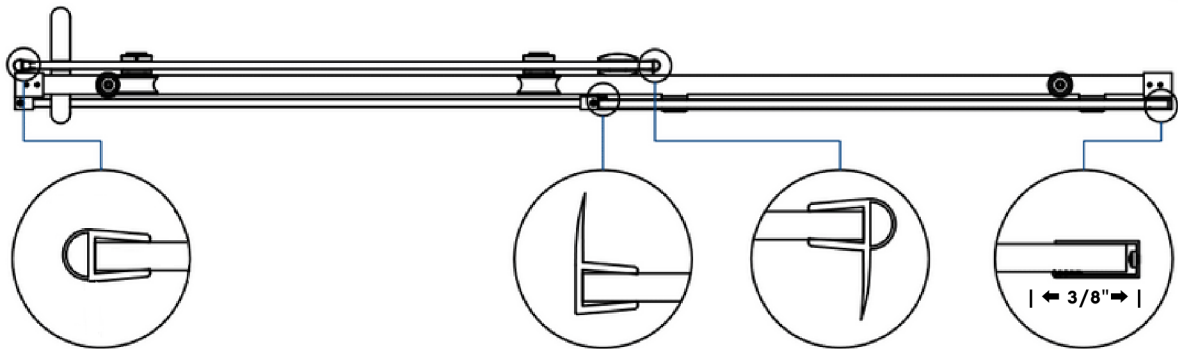

SLIDING PANEL SEAL (EXTERIOR)

FIXED PANEL SEAL

SLIDING PANEL SEAL (INTERIOR)

WALL CHANNEL PROVIDES UP TO 3/8" OF OUT-OF-PLUMB ADJUSTABILITY

PROFESSIONAL, LICENSED INSTALLATION IS HIGHLY RECOMMENDED WITH AT LEAST TWO ADULTS INVOLVED IN THE PROCESS.

DRAWING SHOWN IS REPRESENTATIVE OF ACTUAL PRODUCT AND NOT TO SCALE. ASTON GLOBAL RESERVES THE RIGHT TO MODIFY OR UPDATE THE MATERIAL OR HARDWARE PICTURED WITHOUT PRIOR NOTICE FOR THE PURPOSE OF PRODUCT IMPROVEMENT AND CUSTOMER SATISFACTION.

QUESTIONS & PRODUCT SUPPORT



SUPPORT@ASTONBATH.COM



1-877-424-9699 | OPTION
(8:30AM - 5:30PM CST; MON TO FRI)



ASTONBATH.COM