

Before Getting Started

- Read the instructions carefully prior to assembling the product.
- When you open the package with a sharp tool like a cutter knife, be careful not to damage the components inside.
- Carefully remove all packaging materials and retain for future use.
- Keep all hardware parts and packaging out of reach of small children.
- Choose a clean, level, spacious assembly area. Avoid hard surfaces that may damage the product.
- Ensure that you have all required contents for complete assembly.
- Take care when lifting. Assemble the product in close proximity to where you intend to position the item.

WARNING: -Risk of suffocation! Keep any packaging materials away from children.
-Make sure power is completely off at the fuse box.
-Have your fixture installed by a qualified licensed electrician.

Cleaning & Maintenance

- For respective shade surfaces, use the appropriate cleansers, i.e. glass cleaner, acrylic polish, and wood polish.
- Clean with soft cloth and a mild detergent. DO not use abrasive cleaner.
- Periodically (every 90 days) make sure that the screws are fully tightened.
- Prolonged exposure to heat sources may cause glazing, melting and scorching, or even cause color to fade.

NOTE



This luminaire can be dimmable if with an appropriate Triac dimmer.



Always use UL recognized wire connectors for connections.



For indoor or outdoor application.



Suitable for wet locations.

ilucezzo

INSTALLATION SHEET

640888

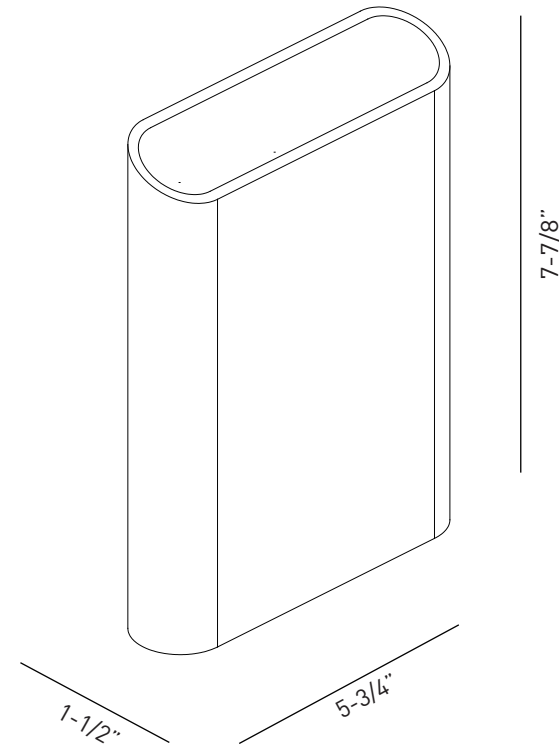

ZHONGSHAN GUZHEN LCZ LIGHTING & ELECTRICAL EQUIPMENTS FACTORY
NO.480, DONGAN NORTH RD., GUZHEN, ZHONGSHAN, GUANGDONG, CHINA
TEL: 86-760-22310601

ADDITIONAL PARTS (included)

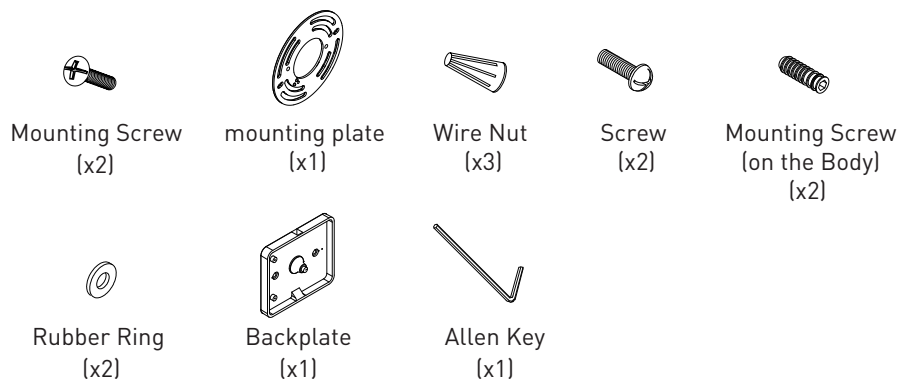

INSTALLATION INSTRUCTIONS

- 1** Install mounting plate to junction box with mounting screws supplied. Make sure black and white wires of junction box run through the middle opening of the mounting plate.

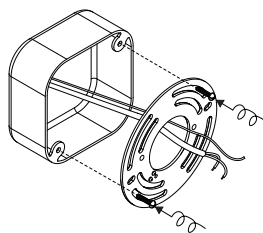

- 2** Remove the backplate from fixture by untightening the screws on top and bottom of fixture.

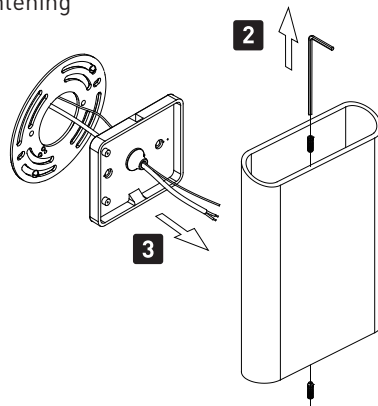

- 3** To ensure that there will be no moisture entering the fixture, pull the cables through the black rubber ring.
Note: black rubber ring needs to be pierced in advance.

- 4** Fix the backplate onto the mounting plate with the supplied screws and rubber rings.

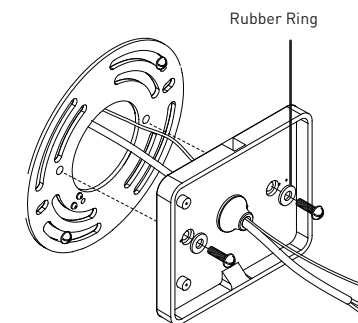

- 5** To make the connections in the compartment: use the included wire nut to match the white wire from the line feed with the white wire from the fixture, repeat with black wire and then connect copper wire (ground) to the green wire. (see connection details)

CONNECTION DETAILS

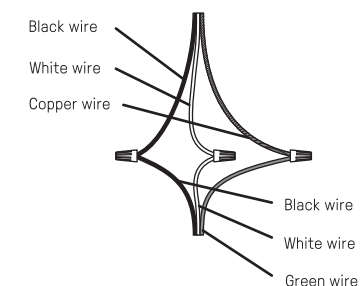

- 6** Secure the fixture on the backplate using the 2 screws.

