

Installation Instruction

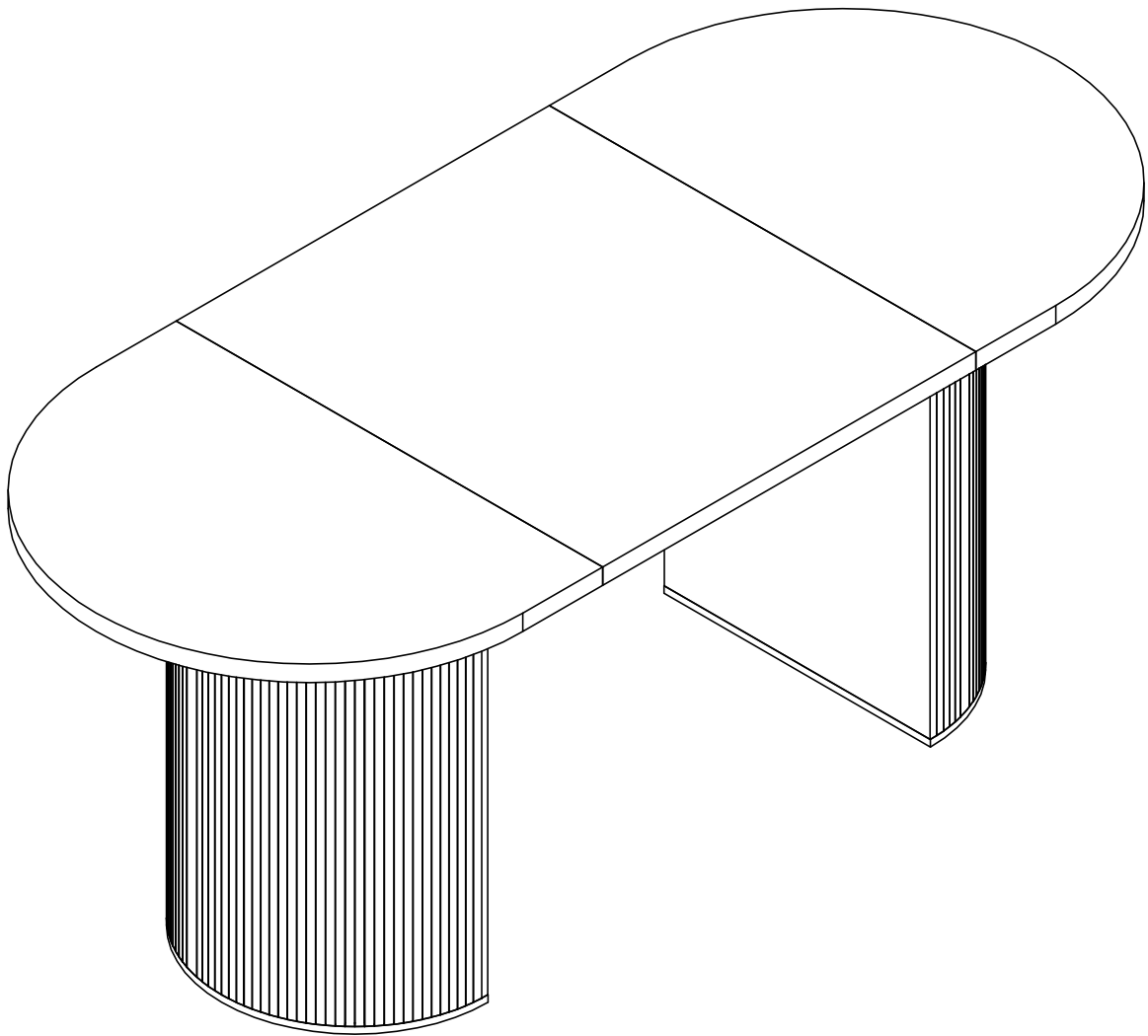

Before Assembly

Tips Before Your Start:

- Remove all wrapping material, including staples & packing straps before you start to assemble.
- DO NOT tighten all screws and bolts until the assembly is completely assembled
- Keep all hardware parts out of reach of children.

QUICKFIT

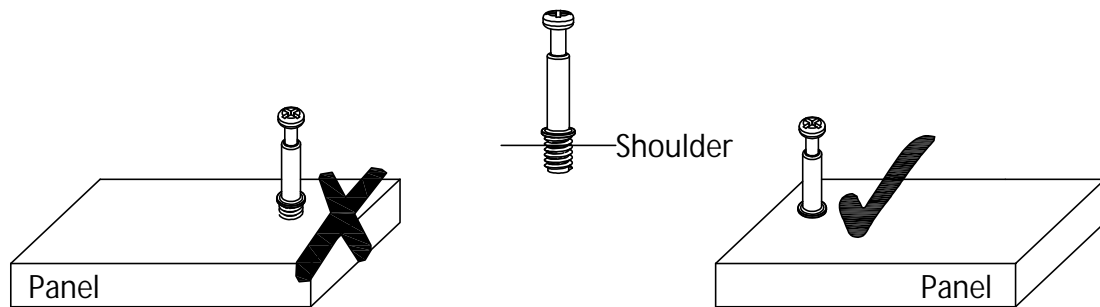

Tighten quickfit until shoulder is flush with panel. Do not overtighten or undertighten.

CAM LOCK

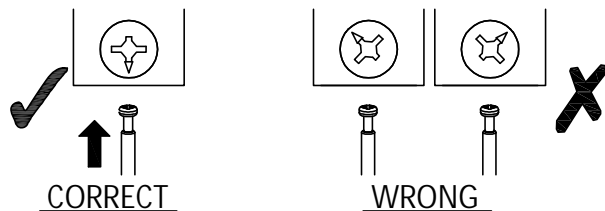

When fitting a cam lock, ensure the starting position is correct before inserting the connecting QUI CKFIT

Quickfit head should be in the centre of the cam lock when the two panels are joined.

Cam lock should be inserted before quickfit.

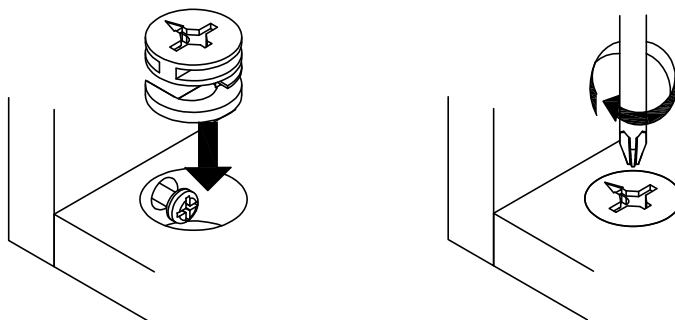

Turn cam lock clockwise to tighten.

Assembling

Estimated time for assembly



45 : 00

What you need

- Use the packaging carton as a working surface to prevent product damage during assembly
- Phillips head screwdriver

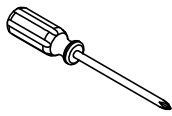

Weight Limitation



100 | **35**
lbs table top | lbs per

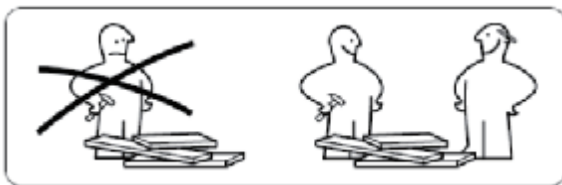

IMPORTANT:

1. Do not tighten bolts / screws completely until all bolts / screws are lined up and inserted into holes.
2. Do not over tighten screws and bolts to avoid stripping

	M6*35	Ⓐx 10pcs
	∅15*12	Ⓑx 10pcs
	M8*30	Ⓒx 8pcs
	∅4*40	Ⓓx 12pcs
	M6*35	Ⓔx 4pcs
	M6*24	Ⓕx 36pcs
	M6*30	Ⓖx 8pcs
	M6*45	Ⓖx 16pcs
	M6*10	Ⓗx 24pcs
	M4*55	Ⓘx 1pc
	∅35*5	Ⓚx 10pcs
	M6*45	Ⓙx 8pcs
	∅21	Ⓜx 10pcs
	①x 1pc
	②x 1pc
	③x 1pc
	④x 2pcs
	⑤x 2pcs
	⑥x 2pcs
	⑦x 2pcs
	⑧x 2pcs
	⑨x 2pcs
	⑩x 4pcs
	⑪x 6pcs

The Accessoriss

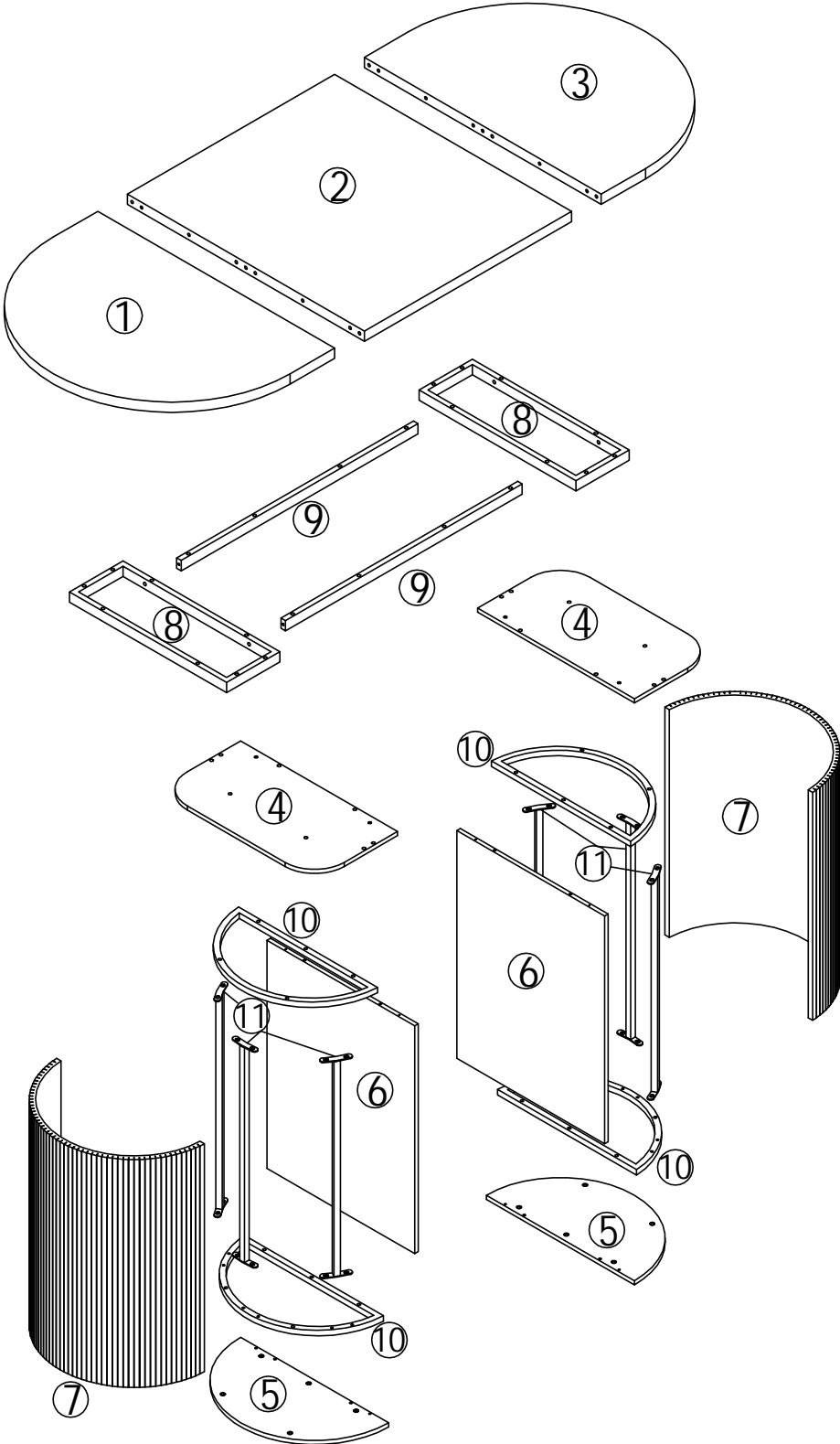

Step 1

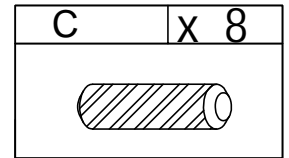
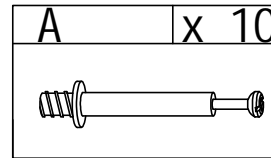

When assembling the panel, please do not touch the groundy directly to avoid scratching the table top

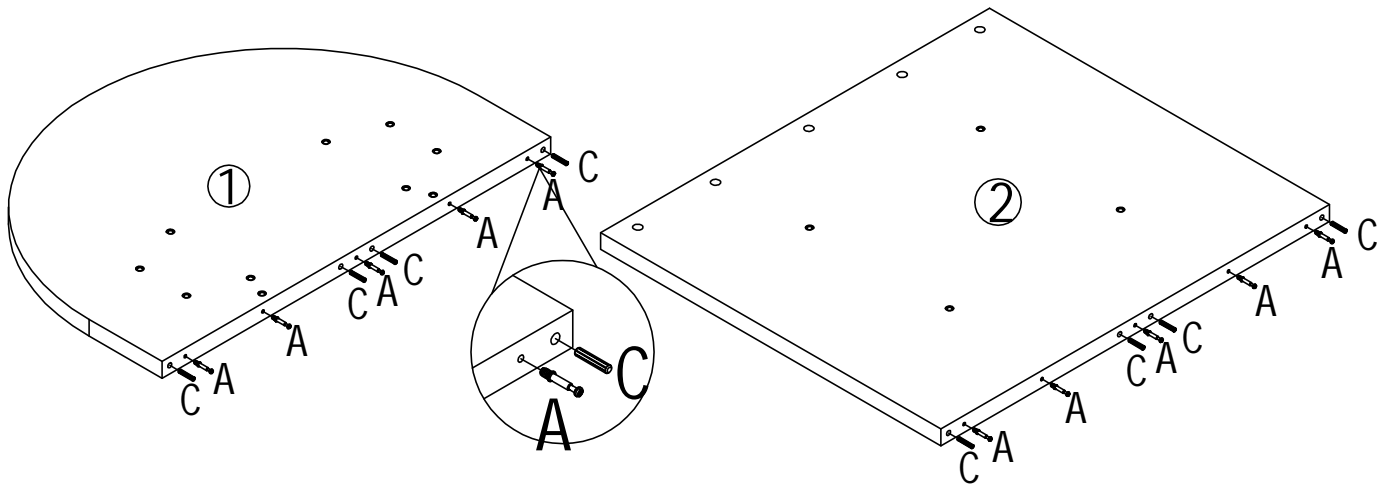

Step 2

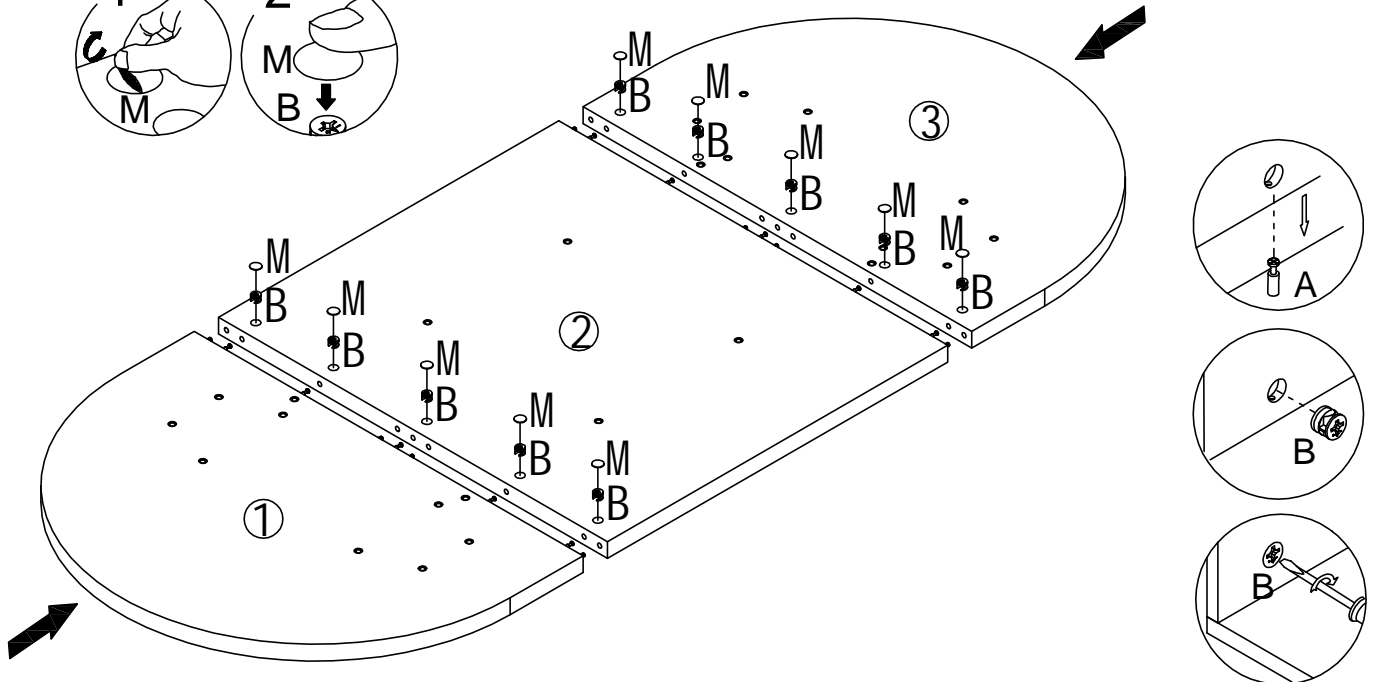
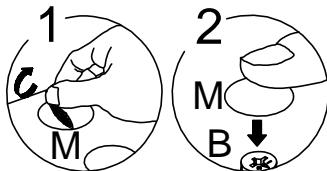
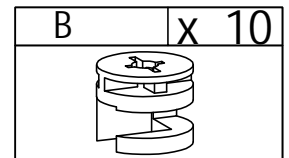
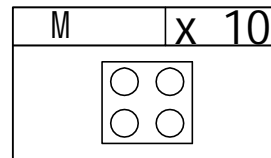

Step 3

J	x 1

E	x 4

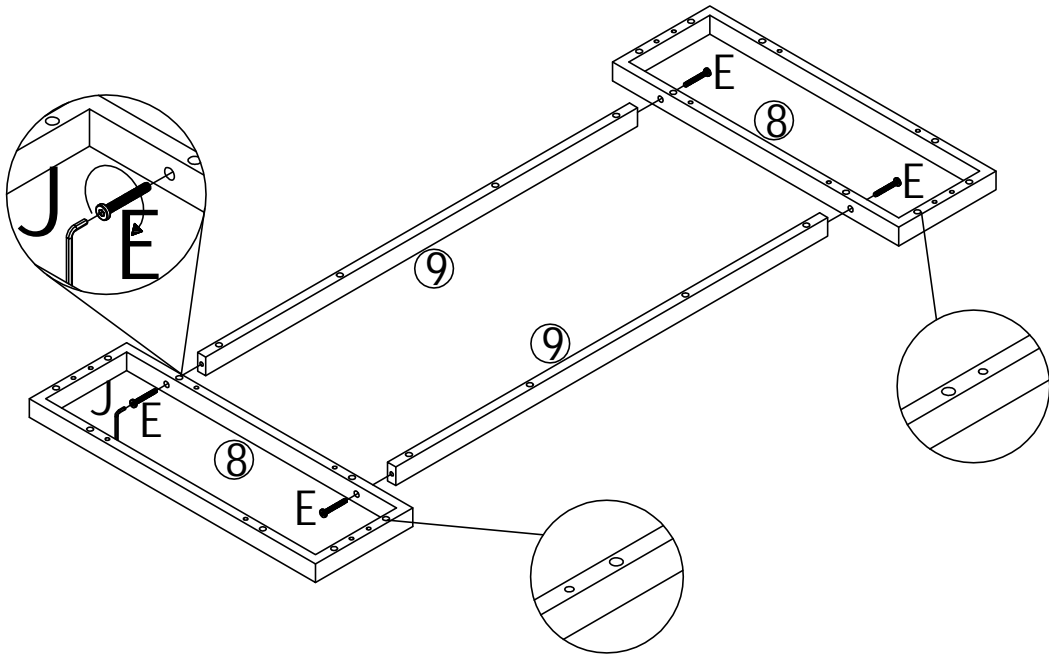

Step 4

L	x 8



H	x 16

J	x 1

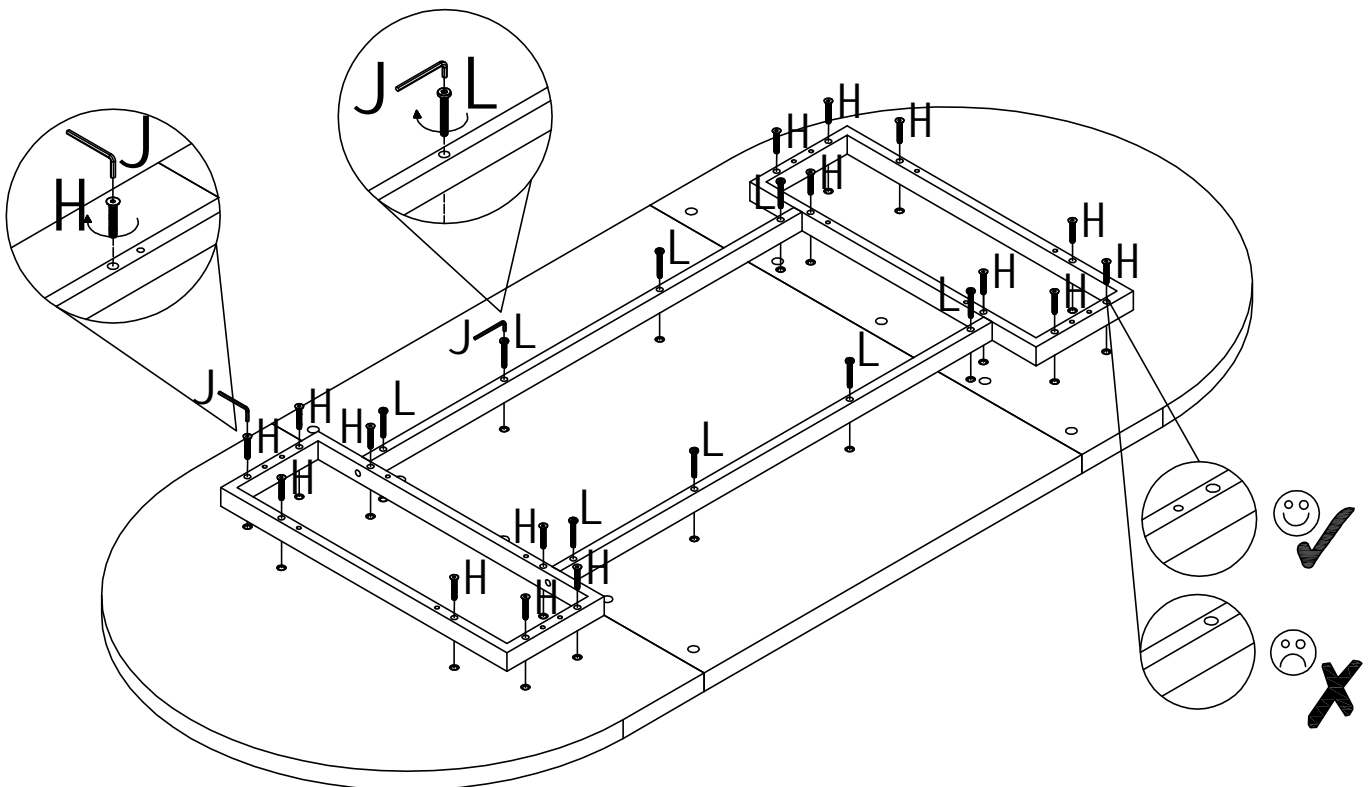
Please attach the iron frame to the plate before proceeding to the next step



Step 5

J	x 1	I	x 24
			

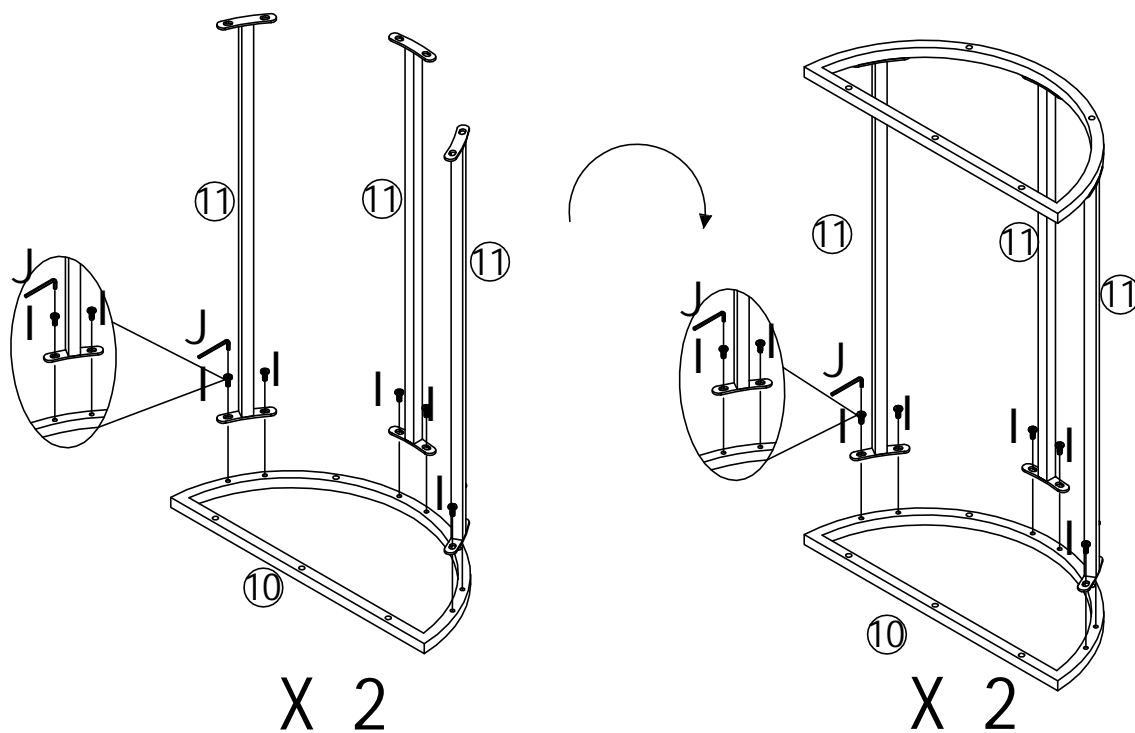

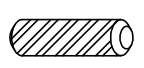
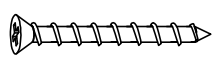

Step 6

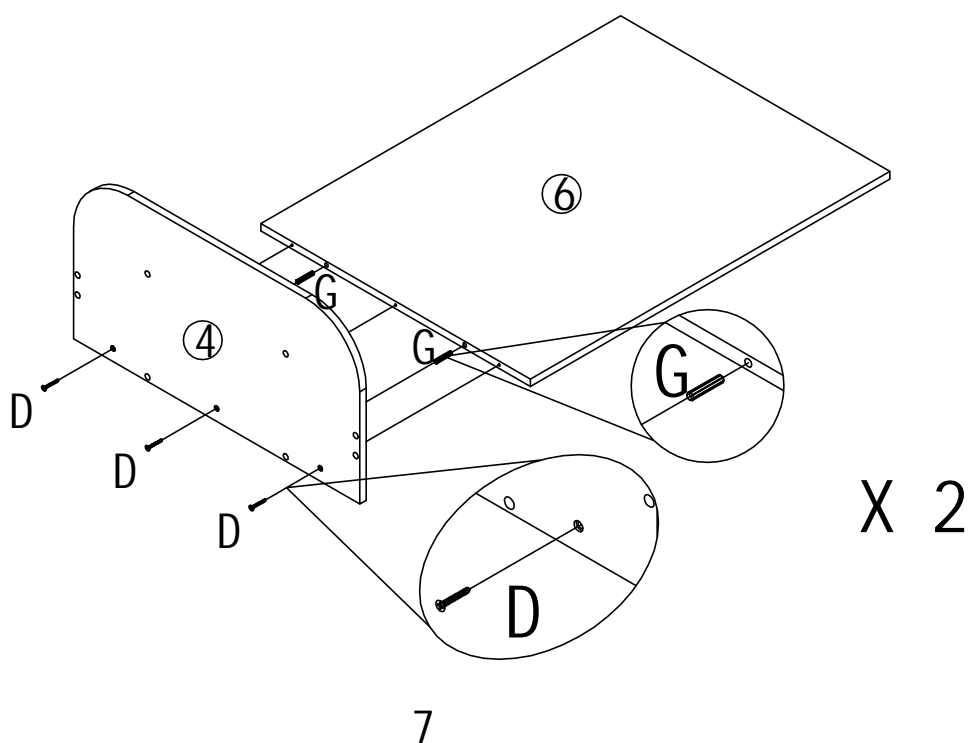
G	x 4	D	x 6
			



Step 7

J	x 1
	

F	x 10
	

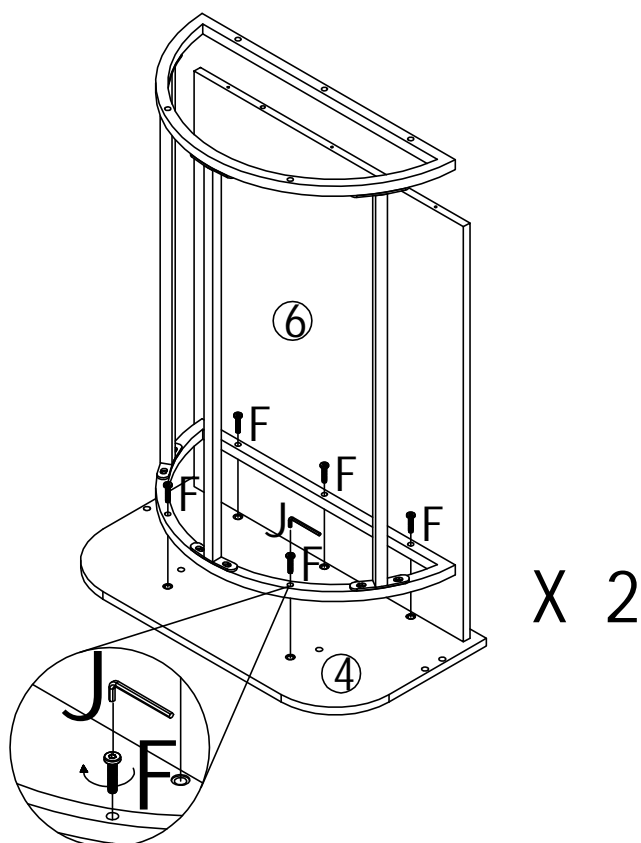

Step 8

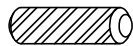
G	x 4
	

F	x 10
	

J	x 1
	

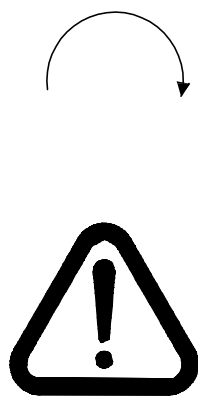

Bottom plate with embedded teeth facing down

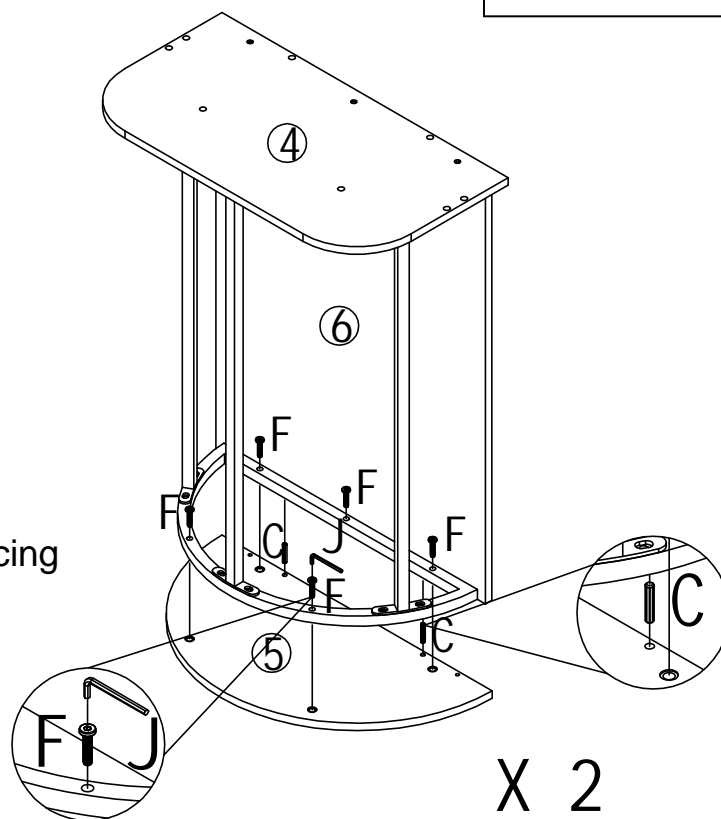

Step 9

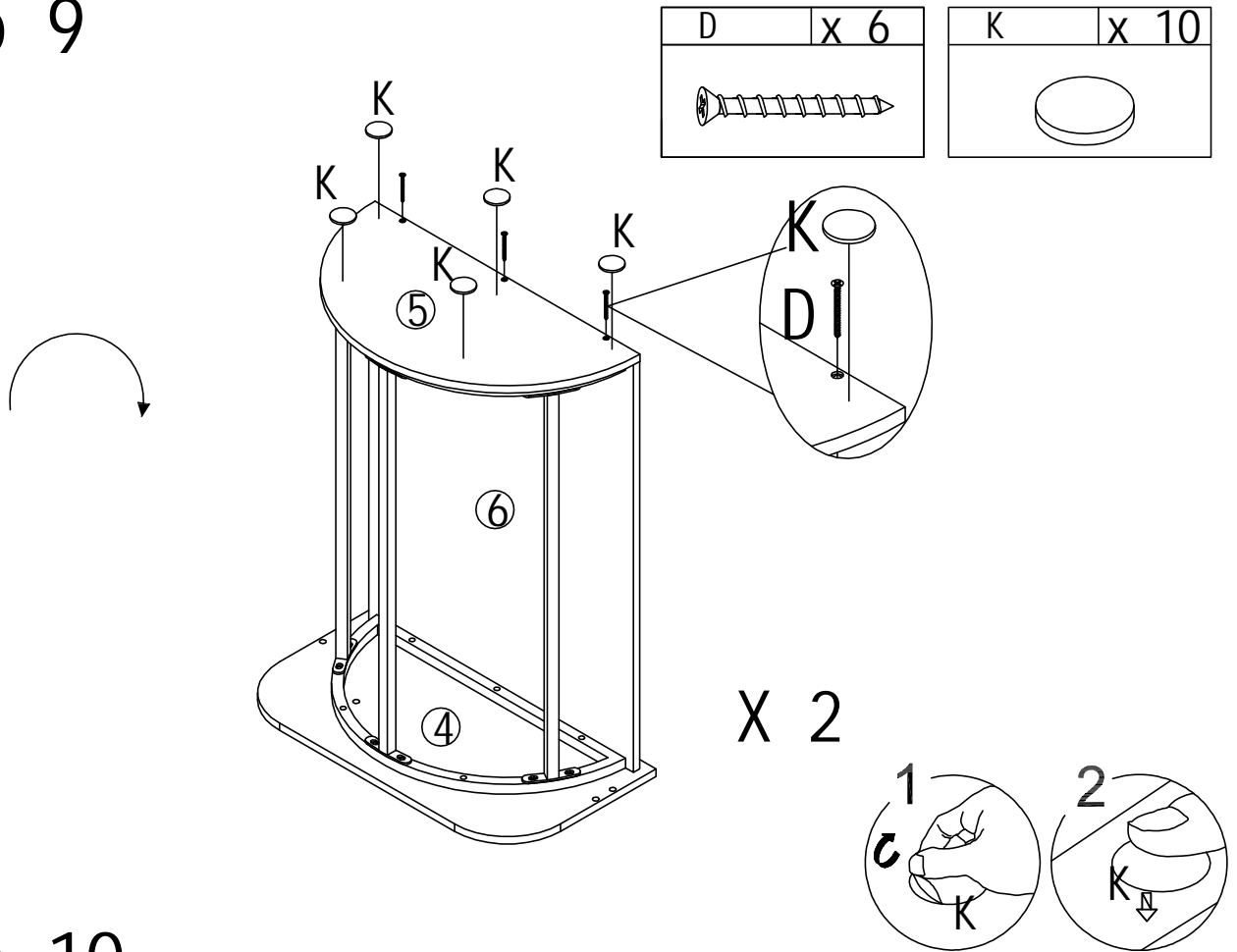

Step 10

Note that there are 16 places where screw F needs to be installed. Be sure to lock all screws tightly

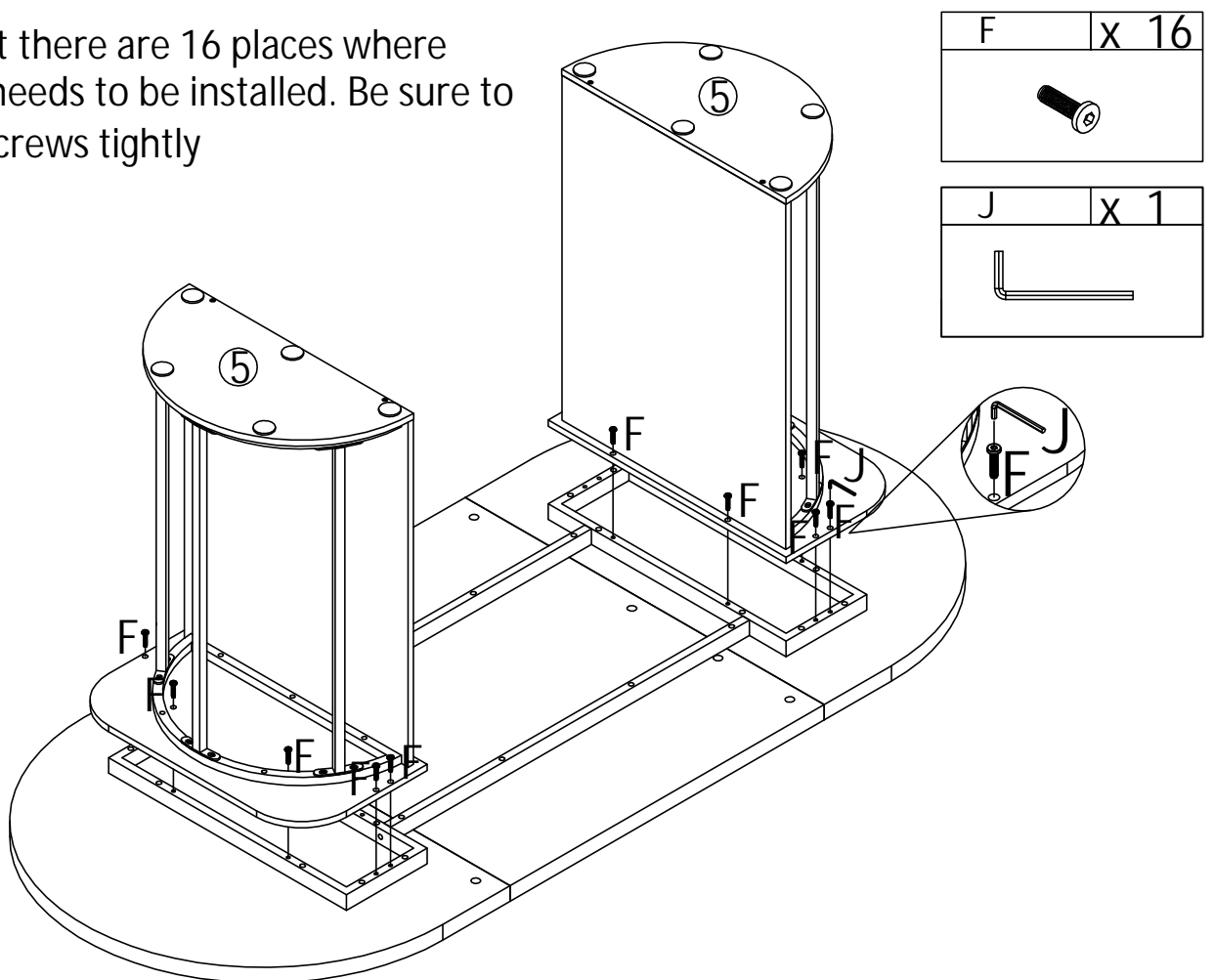

Step 11

Attach Board 7 neatly to the Velcro of iron 10 (Attention: Please fully stretch part 7 and then stick it tightly along the Velcro to avoid gaps that affect the appearance. If there are obvious gaps, tear them off and stick them again.)

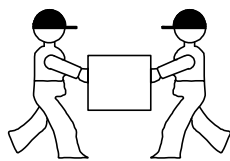
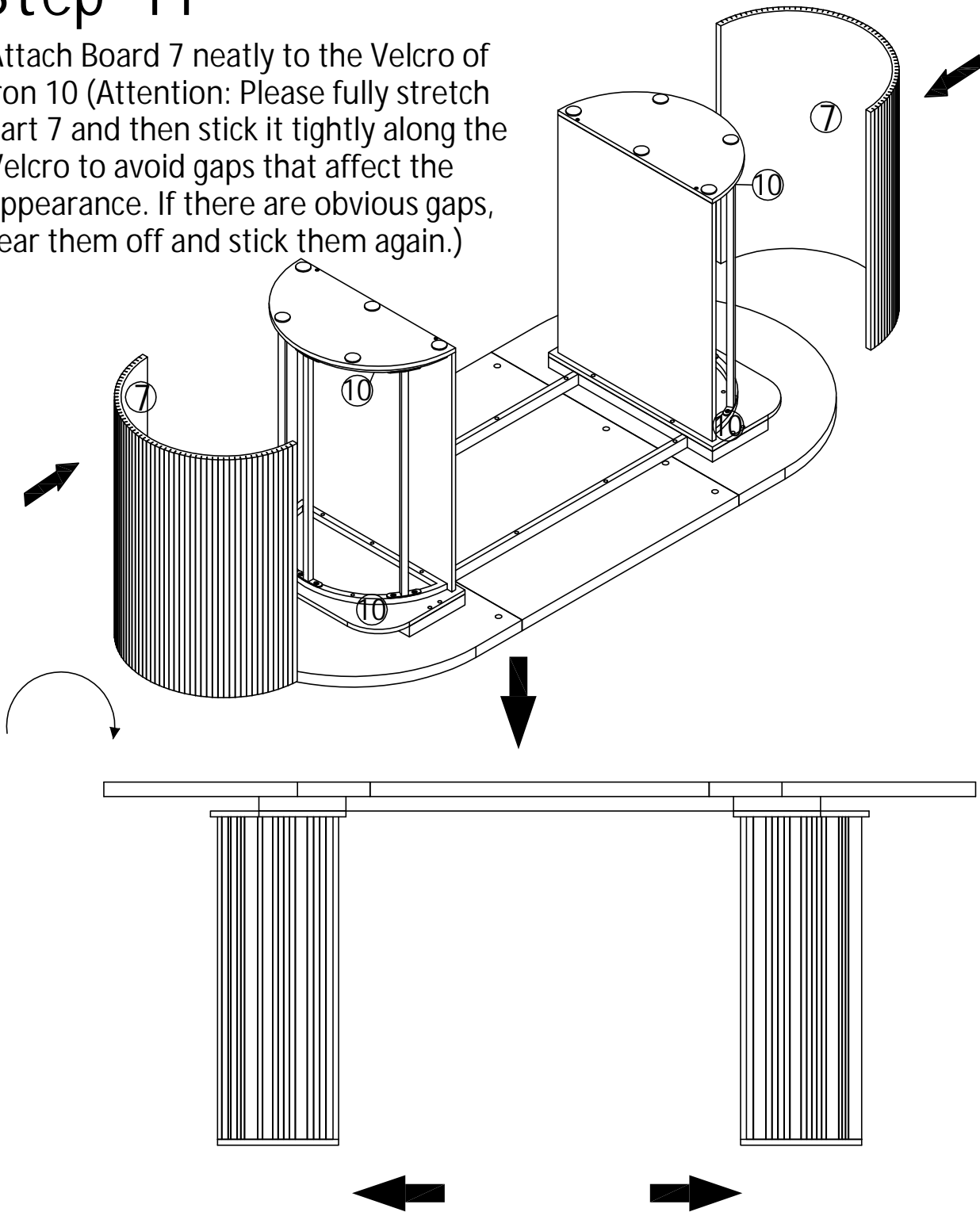

Two people work together to move the table.
Make sure you lift it off the ground.
Don't push and pull.