

2 DRAWER BEDSIDE

ASSEMBLY INSTRUCTION - Please Keep For Future Reference

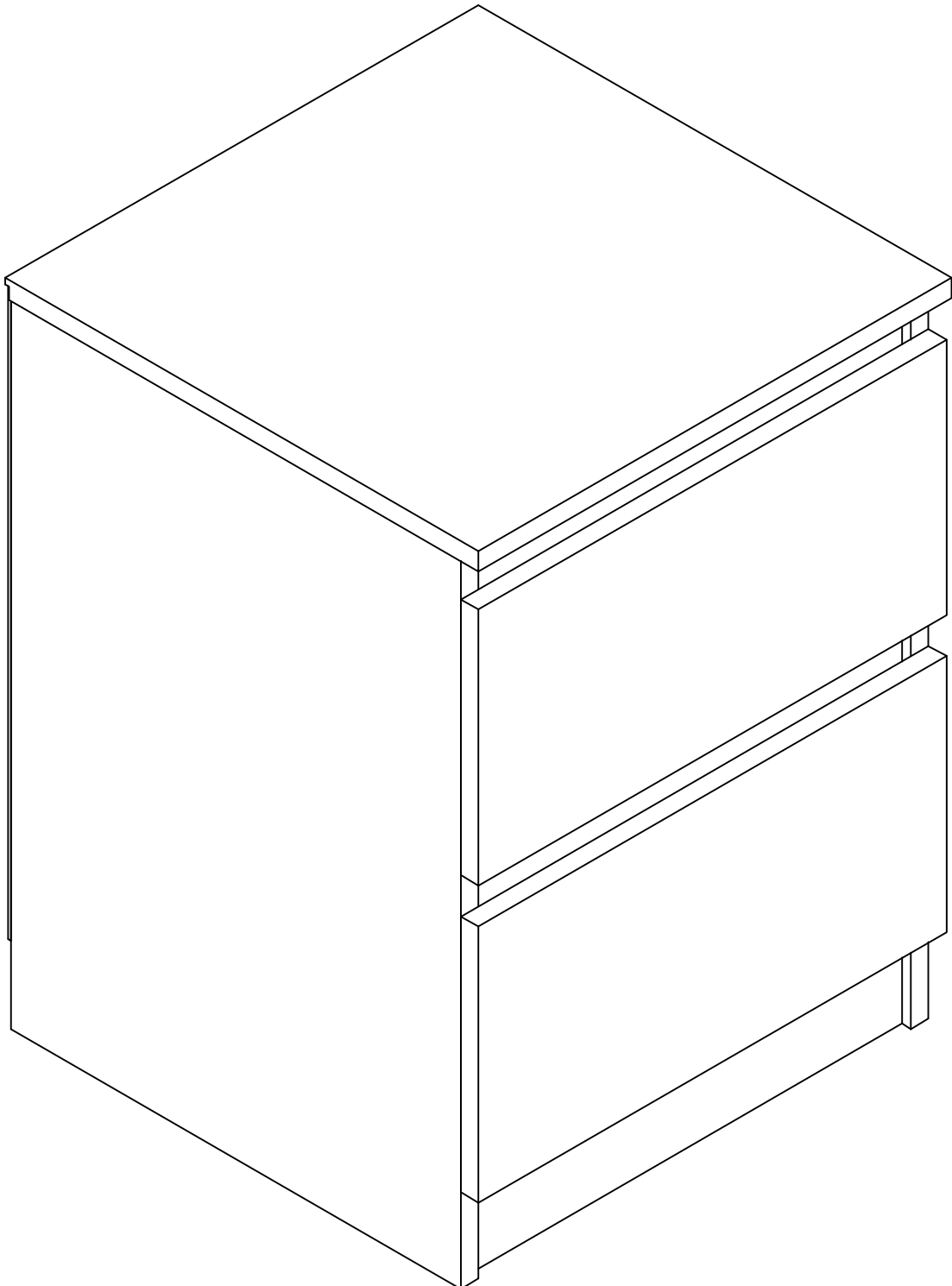

Safety and Care Advice

IMPORTANT - Please Read This Instruction Carefully Before Assembly.

- Check you have all the components and tools listed on page 3.
- Do not stand or put weight on the product, this could cause damage.
- Do not use power drill/drivers for assembly, or the unit may be damaged.
- Remove all settings from the plastic bags and separate them into their groups.
- Assemble the item as close to it's intended position(in the same room) as possible.
- Assemble on a soft level surface to avoid damaging the unit.
- Dispose of all packaging carefully and responsibly.
- Keep children and animals away from the work area, small parts could choke if swallowed.
- Make sure you have enough space to layout the parts before assembly.
- Parts of the assembly will be easier with 2 people.

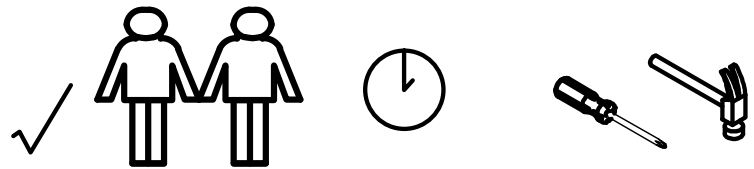

CARE and MAINTENANCE

- Only clean using a damp cloth and mild detergent, do not use bleach or abrasive cleaners.
- From time to time check that there are no loose screws on this unit.
- This product should not be discarded with household waste. Take to your local authority waste disposal center.

General Hints & Tips

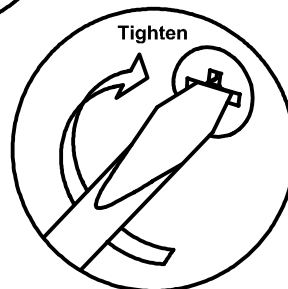
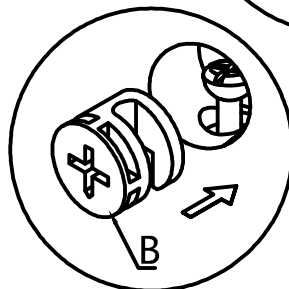
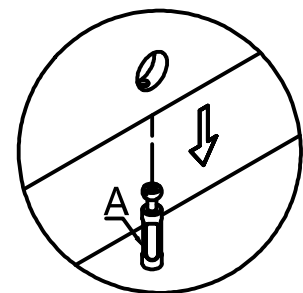
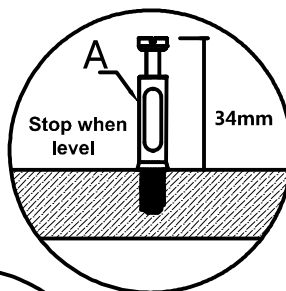
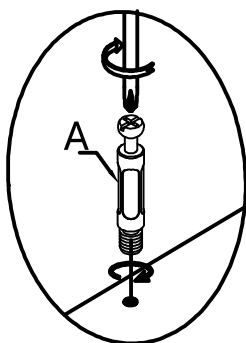





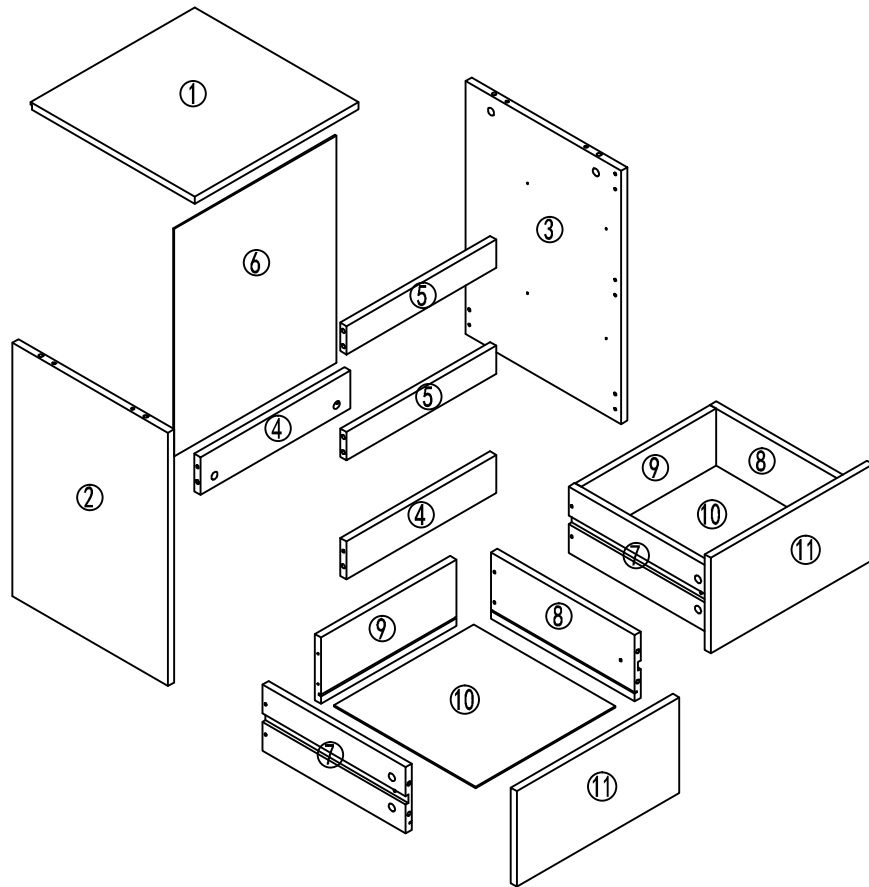

Components and Tools

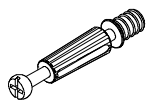
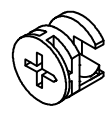
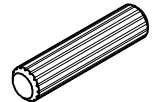
IMPORTANT - Please Check If You Have All The Components and Tools.

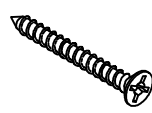
Note: The quantities below are the correct amount to complete the assembly. In some cases more pieces may be supplied than are required.

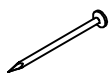
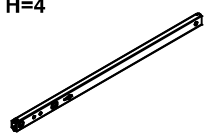

<p>A=24</p>  <p>Peg M6*34mm</p>	<p>B=24</p>  <p>Lock M15*12mm</p>	<p>C=8</p>  <p>Dowel M6*30mm</p>	<p>D=8</p>  <p>Screw M3.5*14mm</p>	<p>E=8</p>  <p>Screw M4*38</p>	<p>F=4</p>  <p>Plastic Feet</p>
<p>G=9</p>  <p>Pin</p>	<p>H=4</p>  <p>Drawer Runner</p>	<p>J=4</p>  <p>Screw M4*12mm</p>			

Assembly Instruction

Step 1

A=12

C=4

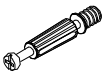

Peg

Dowel

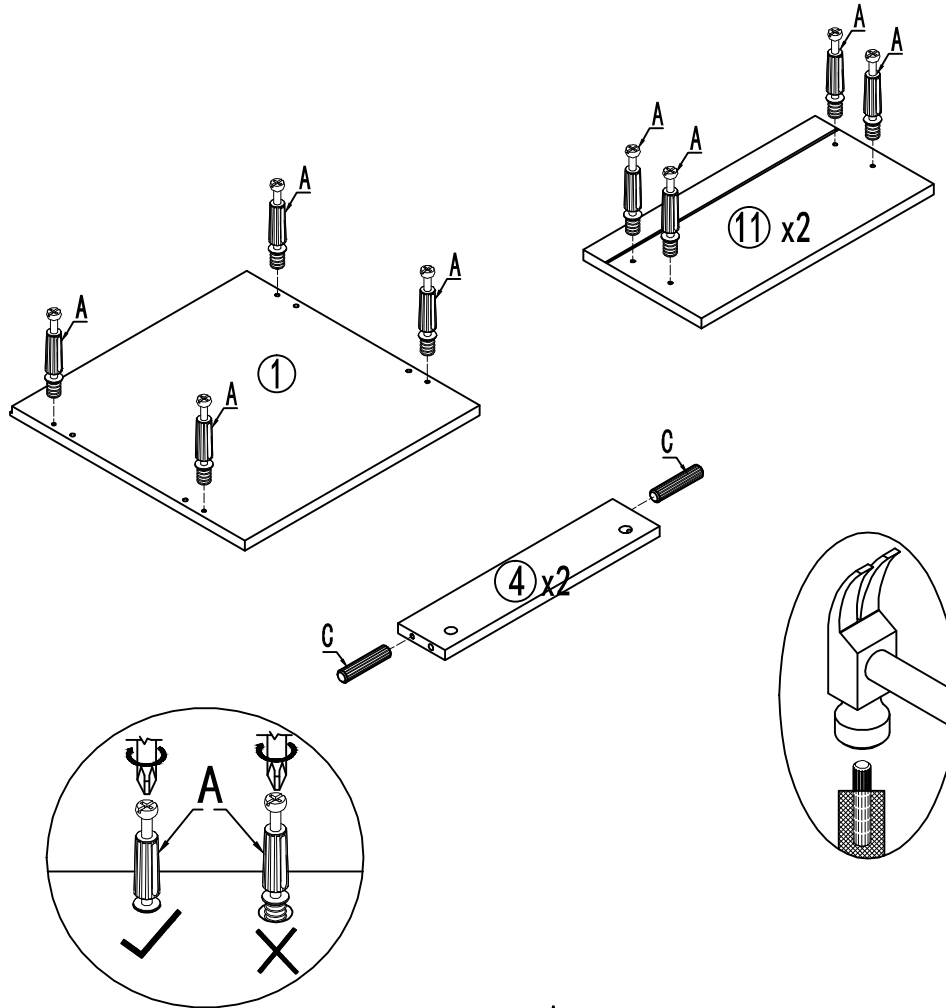

Step 2

A=6

C=2

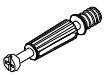

Peg

Dowel

H=2

D=4



Drawer Runner

Screw M3.5*14mm

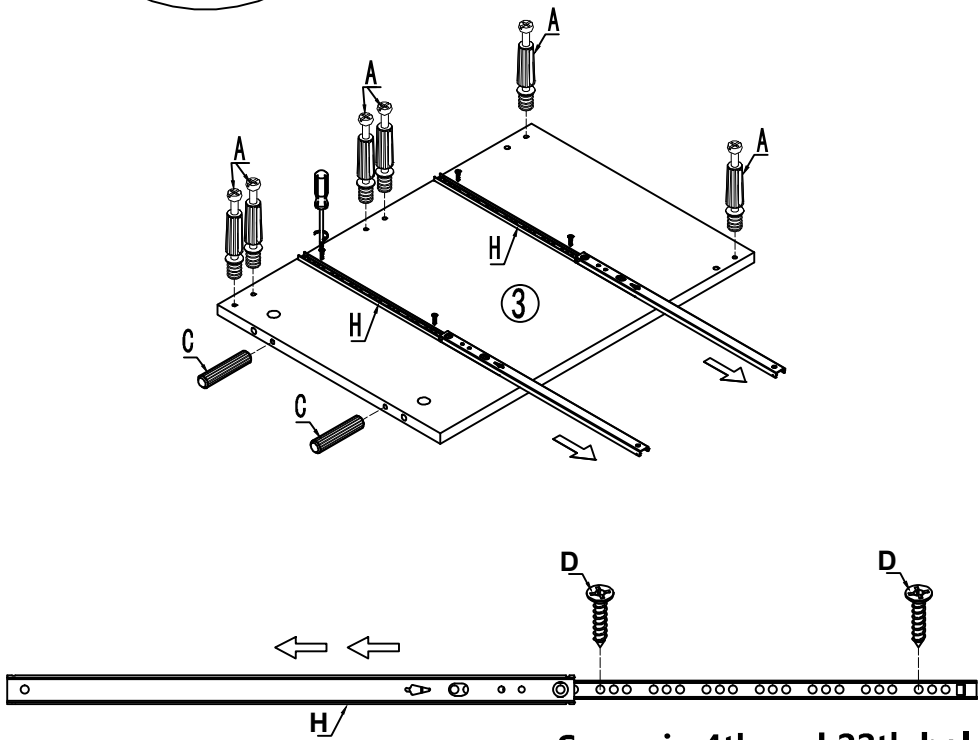

Screw in 4th and 22th holes.

Assembly Instruction

Step 3

A=6 C=2

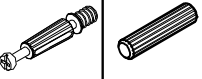

Peg H=2 Dowel D=4

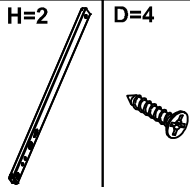

Drawer Runner Screw M3.5*14mm

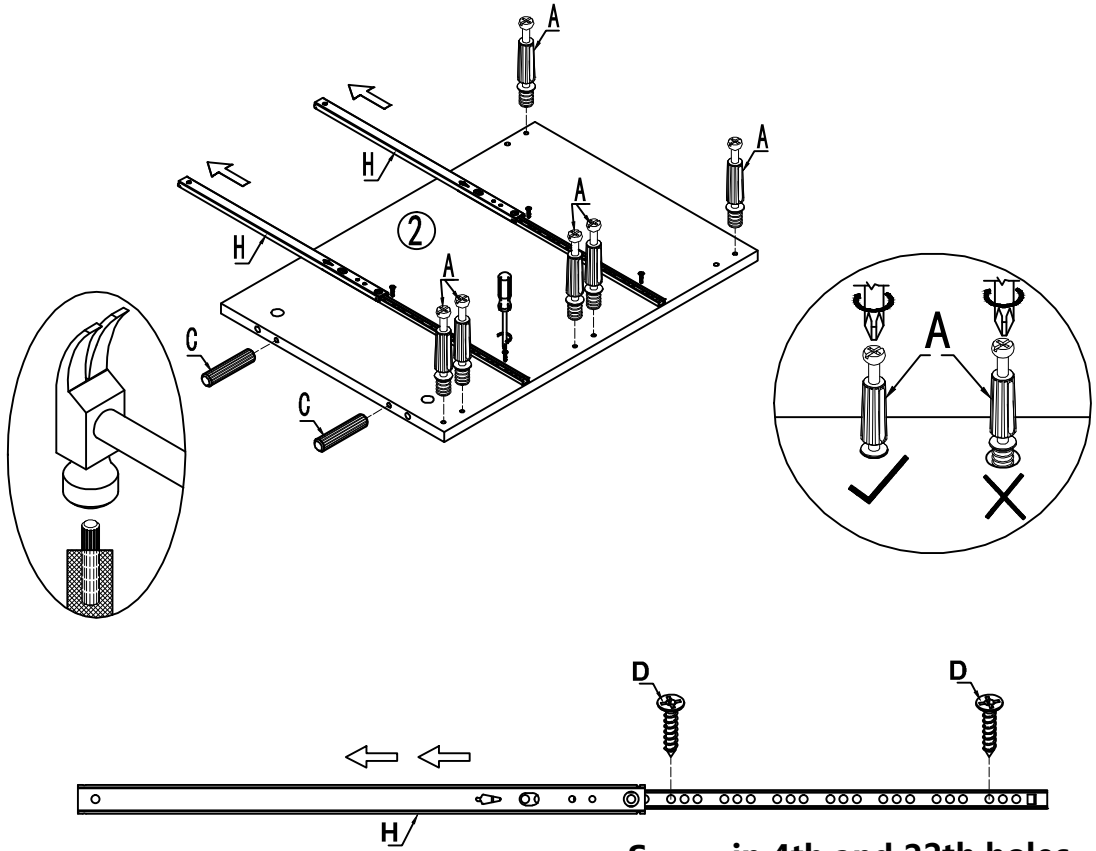

Screw in 4th and 22th holes.

Step 4

B=6



Lock

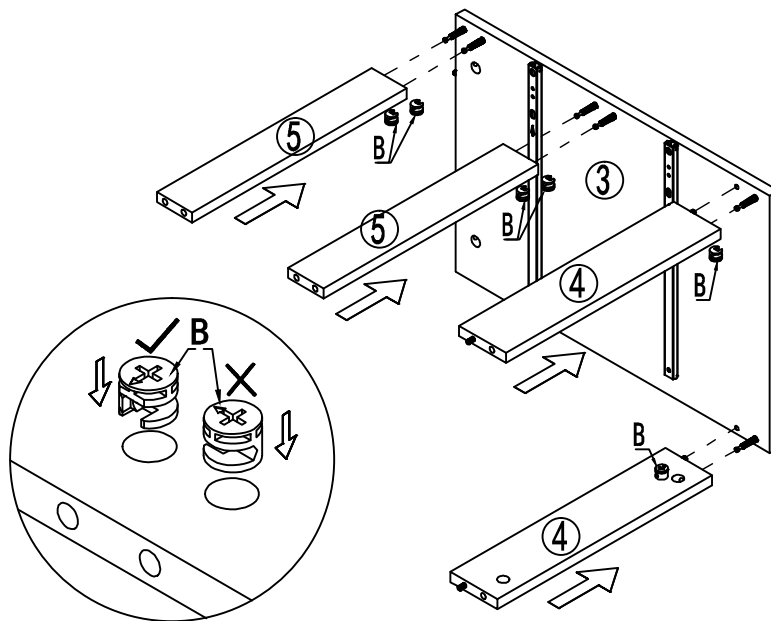

Assembly Instruction

Step 5

B=6



Lock

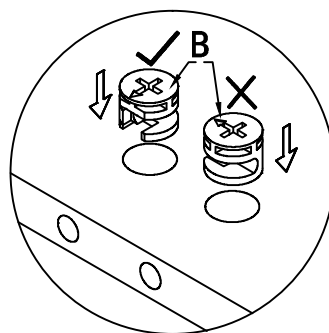
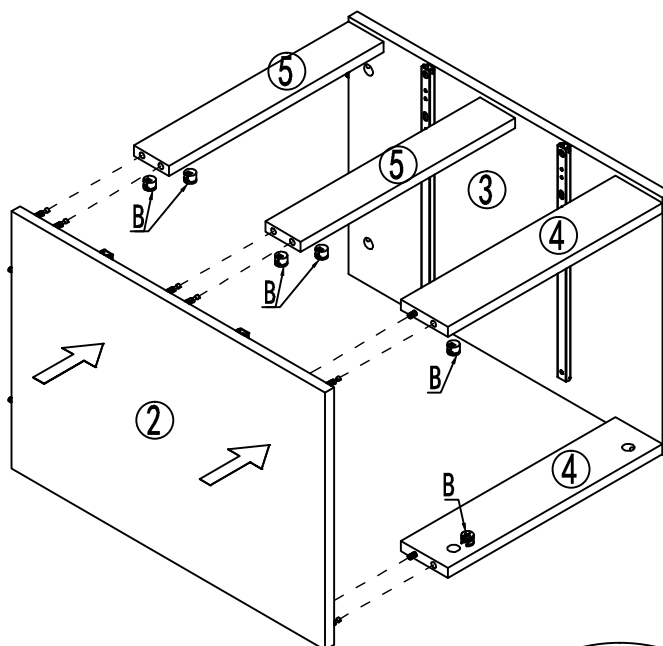

Step 6

B=4



Lock

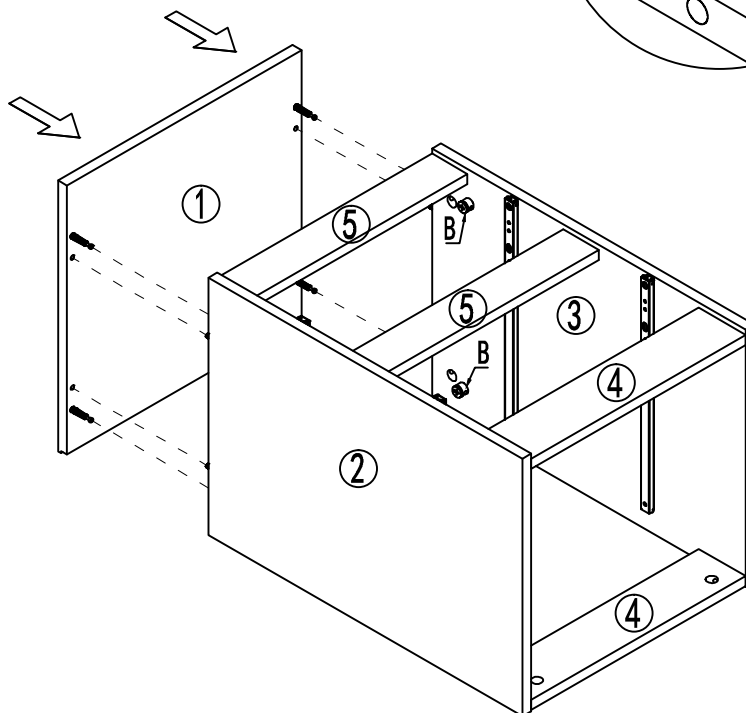

Assembly Instruction

Step 7

G=9

F=4



Pin

Plastic
Feet

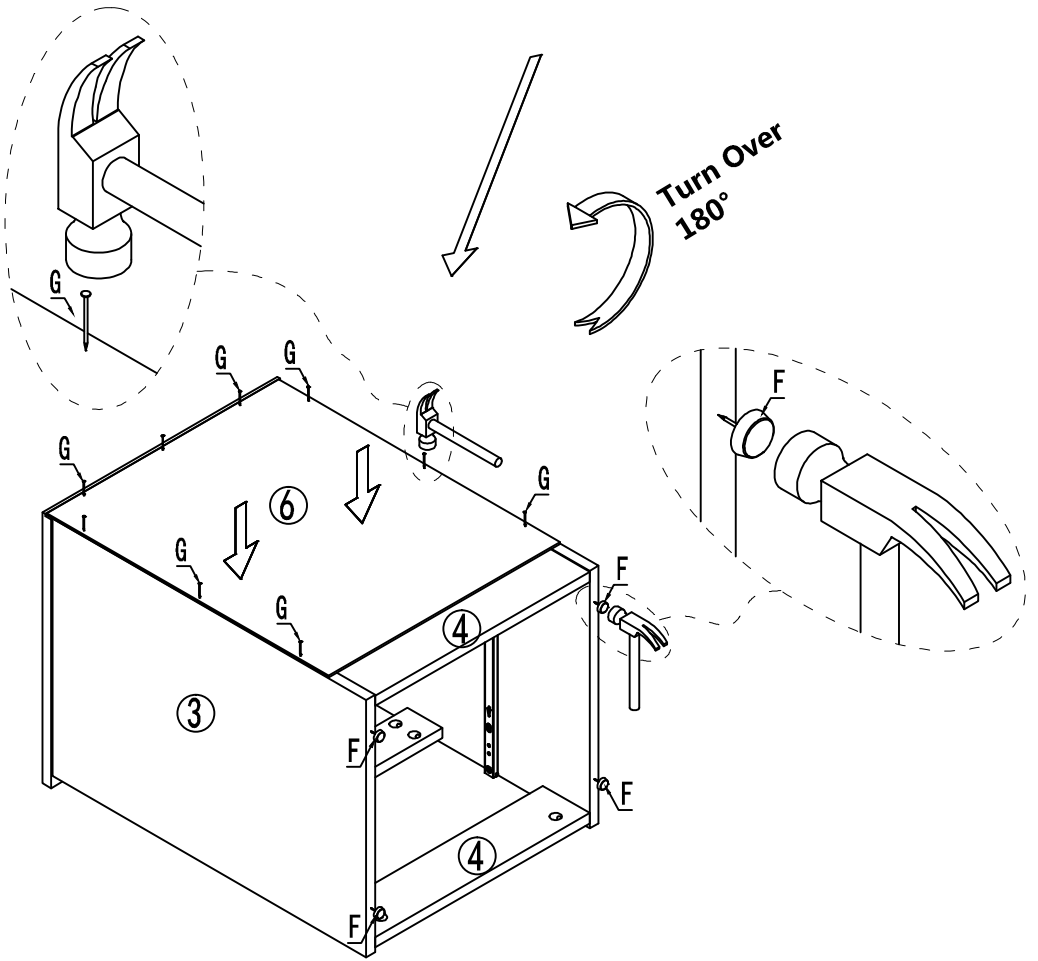

Step 8

B=8



Lock

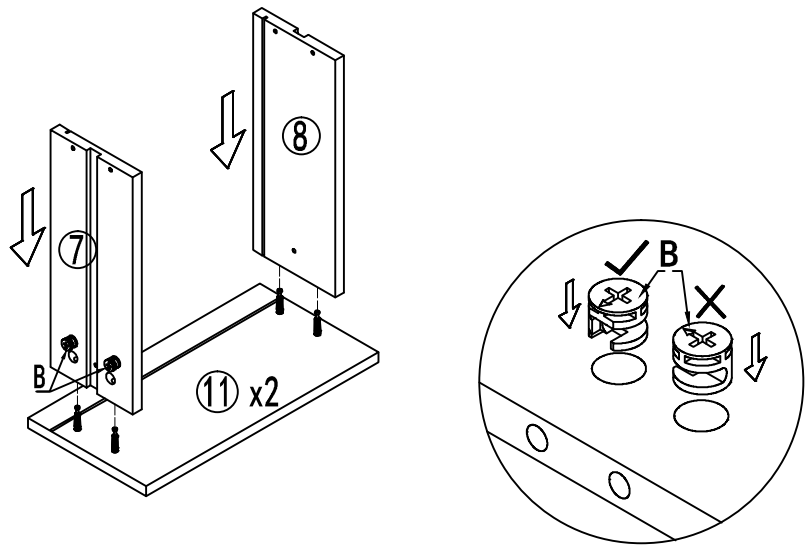

Assembly Instruction

Step 9

E=8



Screw
M4*38

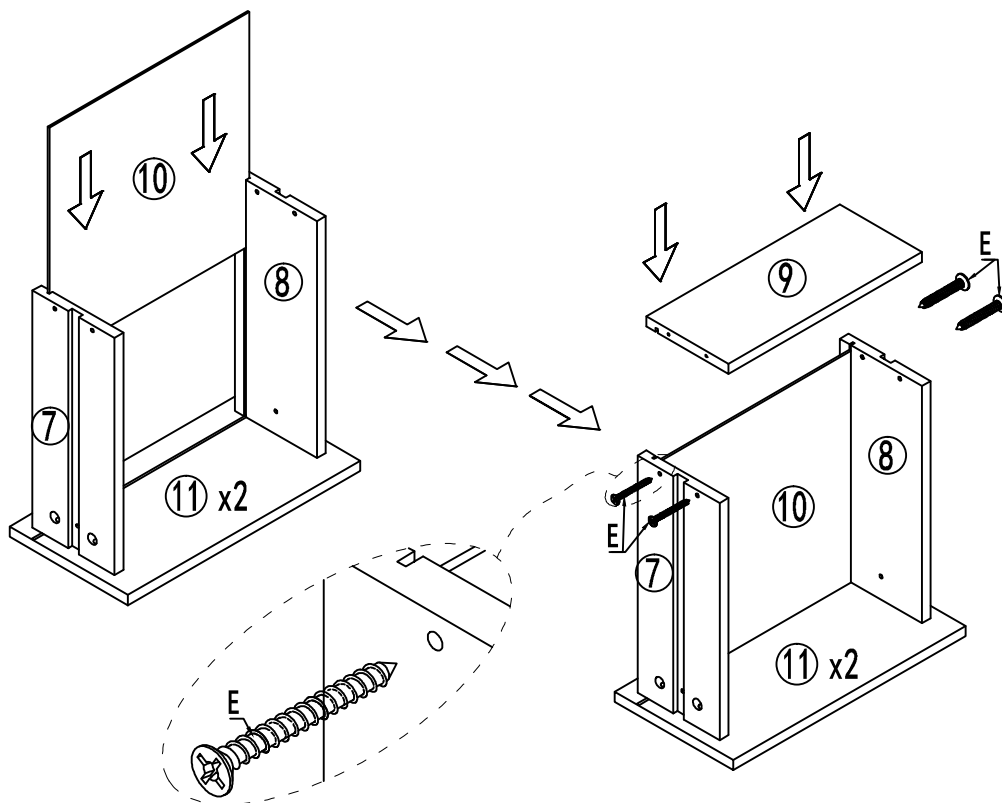

Step 10

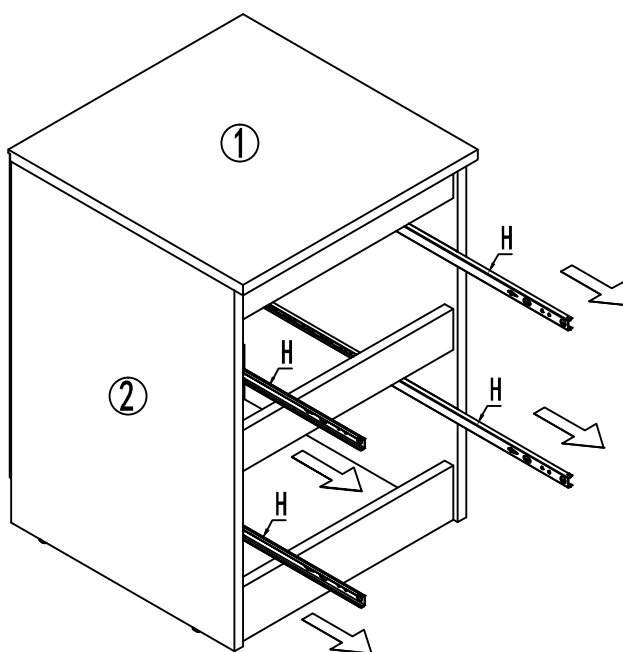

Assembly Instruction

Step 11

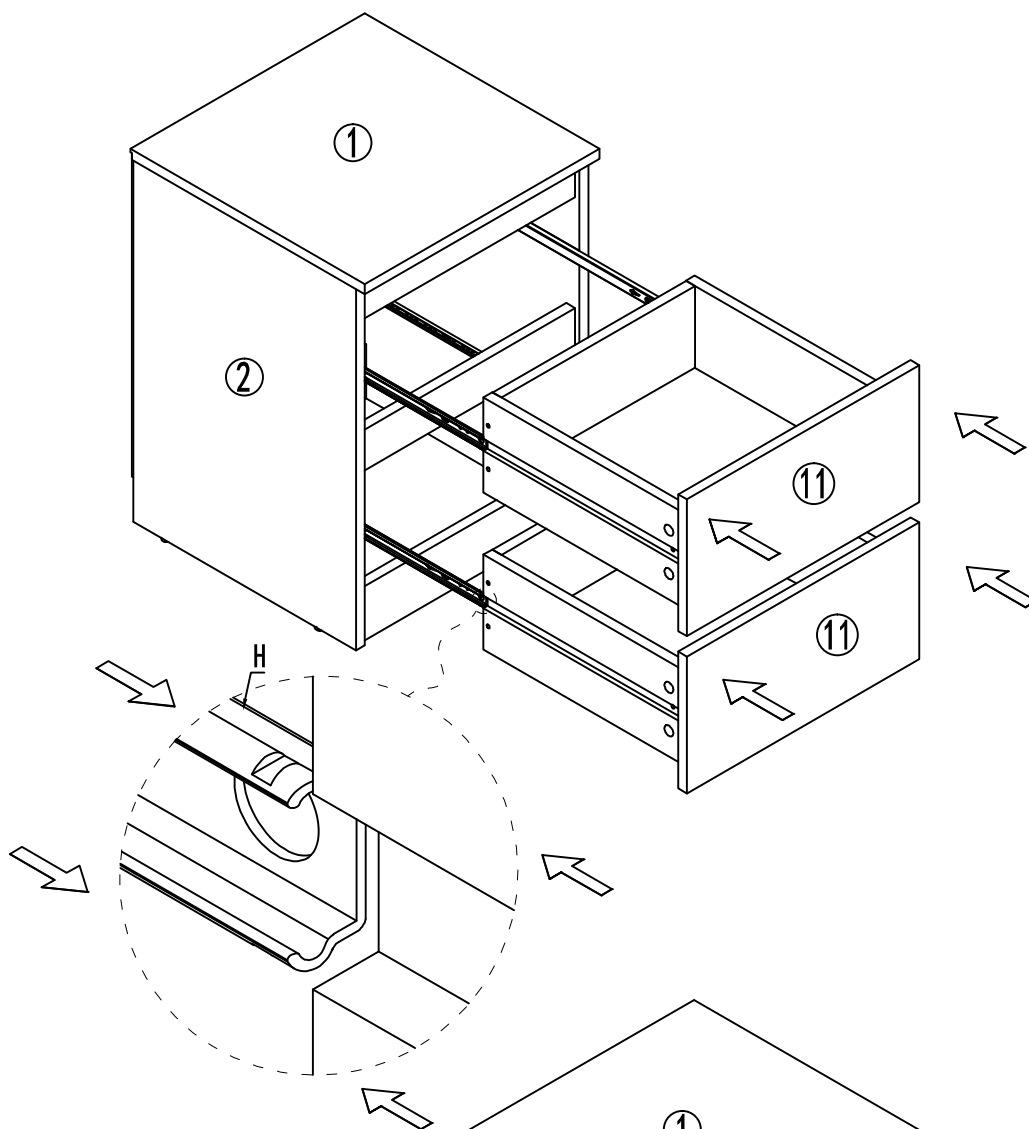

Step 12

J=4



Screw
M4*12mm

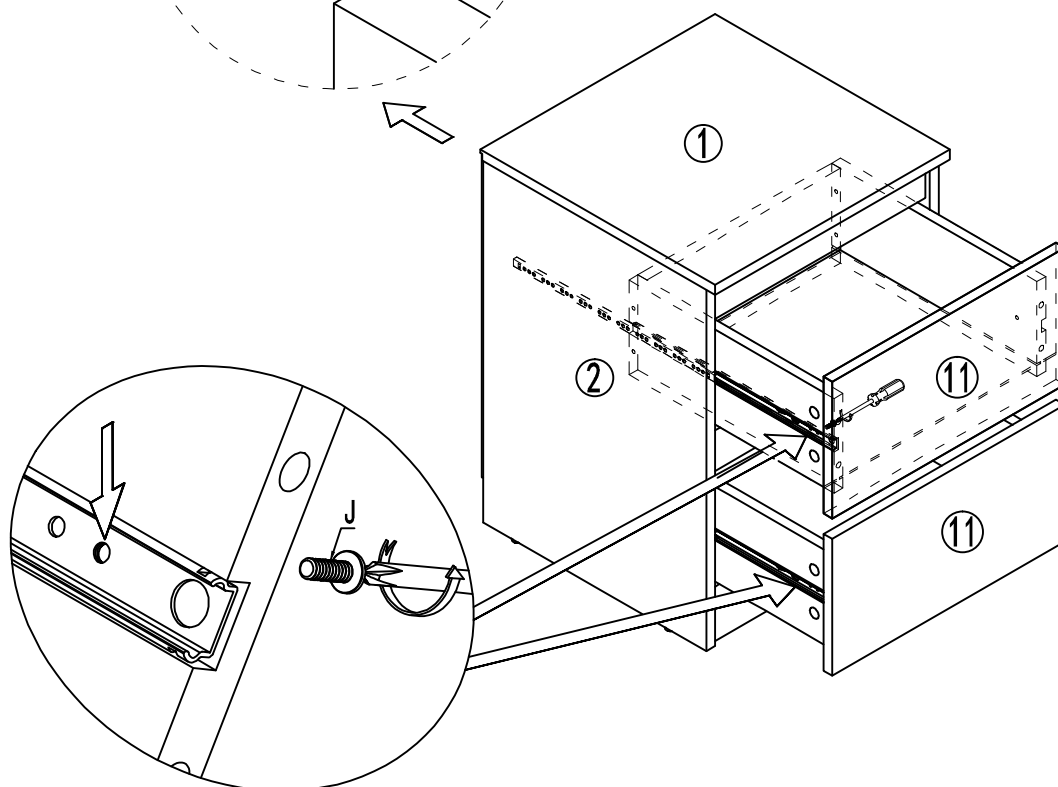

Assembly Instruction

Step 13

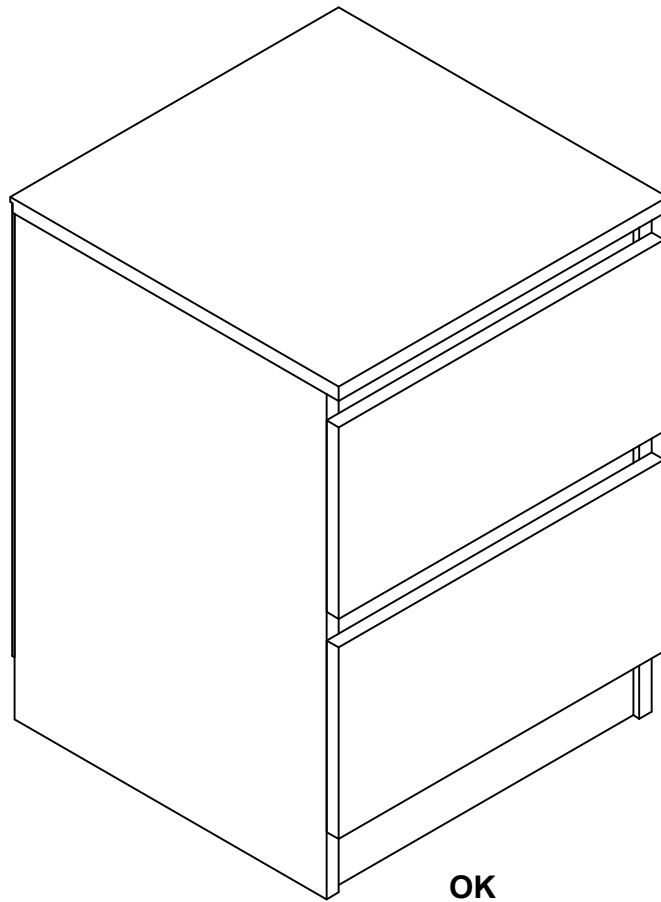

OK