

# LOUVERED PERGOLA INSTRUCTION MANUAL

## 10\*13FT

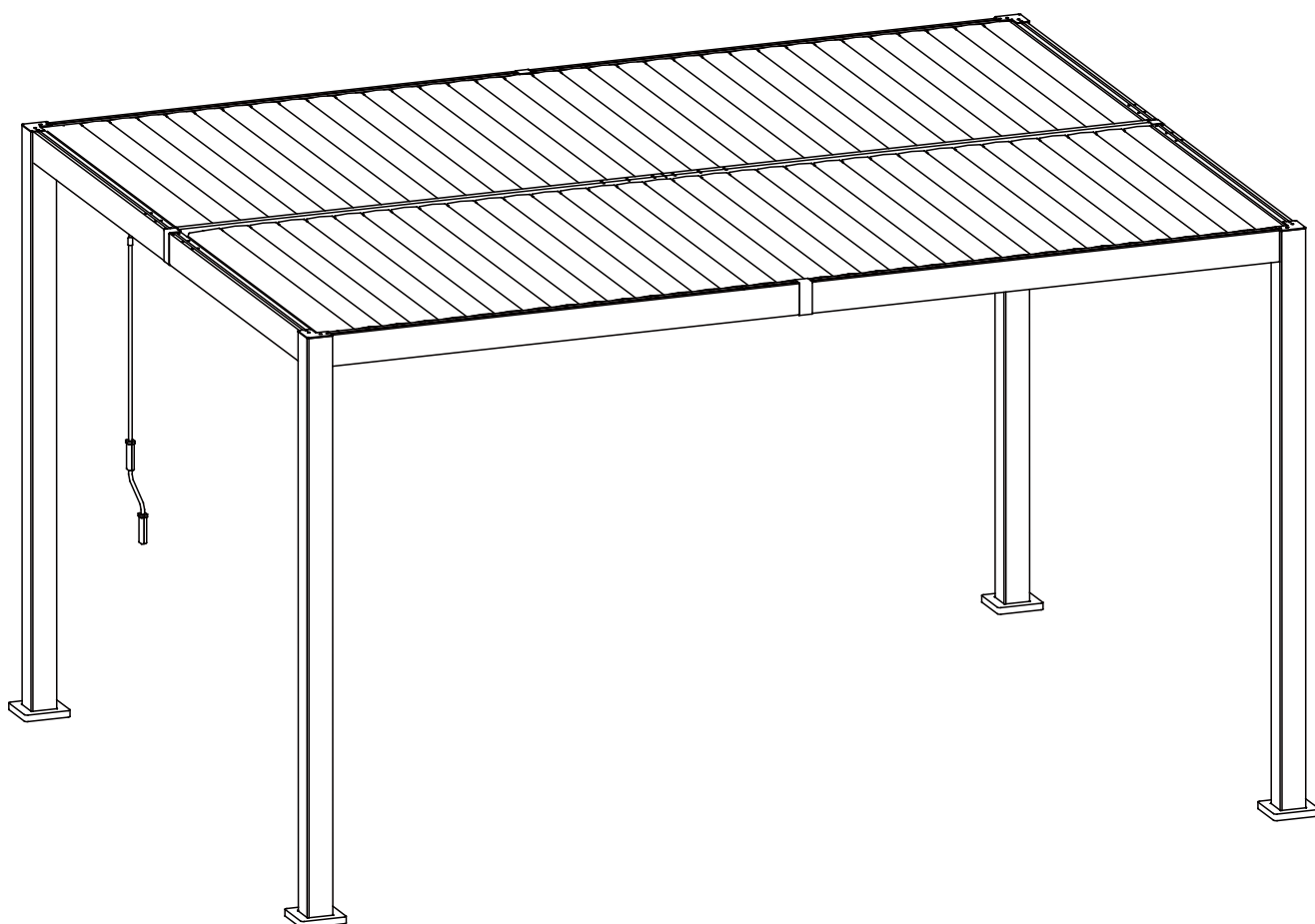



### Note:

Note: The pergola needs to be installed in cooperation with two people. The following tools are not included and needed for assembly:

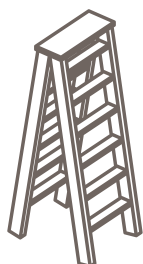

2m Adjustable Ladder

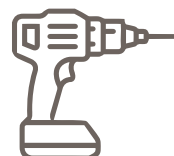

Pistol Drill



Tape Measure













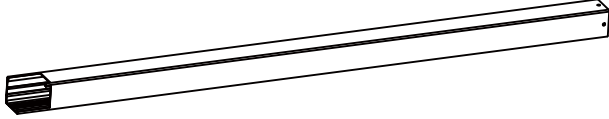
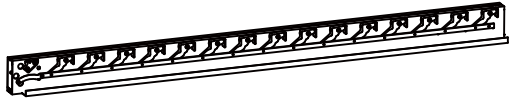

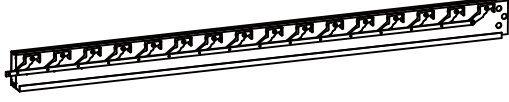

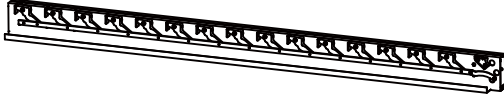

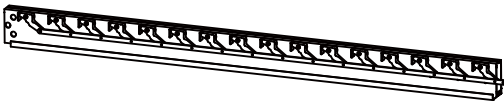

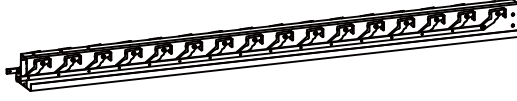

2 people









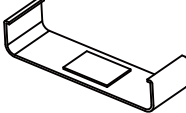
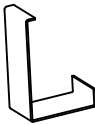



## ! Warning

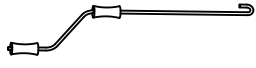



1. Two person assembly is required for this louvered pergola.
2. Please take appropriate actions as heavy rain, wind and snow can damage the gazebo. If necessary please disassemble and store for later use.
3. In snowy conditions, please do not allow the thickness of the snow to be more than 1.97 inches on the roof, this should be cleared as soon as possible for your safety. When the wind speed reaches 61.2km/h, please take measures to avoid the wind.

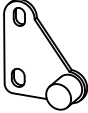





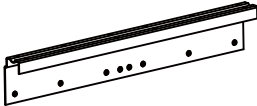
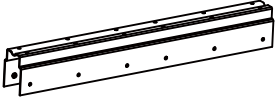

## **! ATTENTION:**

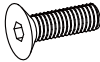
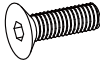
1. Please check the manual carefully and make sure you have received all the parts.
2. If there is any missing, please let us know the letter of the parts you need.
3. If there is any damage, please send clear photos to us, we will check and offer you the best solution soon.

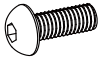
PART NO	DESCRIPTION	QTY	PART NAME
A		4	STANDING POLE
B	 	1	BEAM (LEFT)
B1	 	1	BEAM (LEFT)
C	 	1	BEAM (RIGHT)
C1	 	1	BEAM (RIGHT)
D	 	1	BEAM (MIDDLE)
D1	 	1	BEAM (MIDDLE)
E	 	1	BEAM (BACK)
E1	 	1	BEAM (BACK)
E2	 	1	BEAM (FRONT)
E3	 	1	BEAM (FRONT)
F		1	Middle beam flume covered
F1		4	SIDE BEAM FLUME COVERED

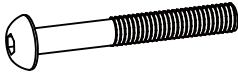

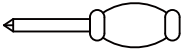
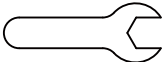
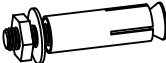

PART NO	DESCRIPTION	QTY	PART NAME
G		2	LOUVER BOARDS
H		66	LOUVER BOARDS
I-1		2	JOINT LEVER
I-2		2	JOINT LEVER
J		1	CRANK
K		4	CORNER POST COVER
L		2	MIDDLE BEAM FITTING
M		2	TURBINE (LEFT)
N		2	TURBINE (RIGHT)
O		4	FOOT PLATE
Q		2	FIXTURE (LEFT)
R		2	FIXTURE (RIGHT)
S		4	SIDE BEAM U TUBE

PART NO	DESCRIPTION	QTY	PART NAME
T		2	MIDDLE BEAM U TUBE
U		4	FLAT ALUMINUM BAR CONNECTOR
V		4	SIDE BEAM CONNECTOR
W		1	MIDDLE BEAM CONNECTOR
X		1	GLUE
Y		4	FOOT PLATE COVER

PART NO	DESCRIPTION	QTY	PART NAME
AA	 M6*18	44	
BB	 M6*15	16	
CC	 M6*13	4	
DD	 M4*12	4	
EE	 M6*10	104+2	
FF	 M6	8	
GG	 M6*40	4	
HH	 M5*12	12	
II	 5mm  4mm  4mm	3	
JJ		1	
KK	 10mm	1	
MM	 M6*50	16	

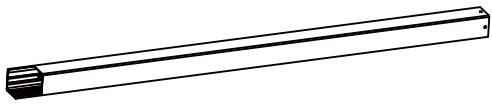
# STEP 1



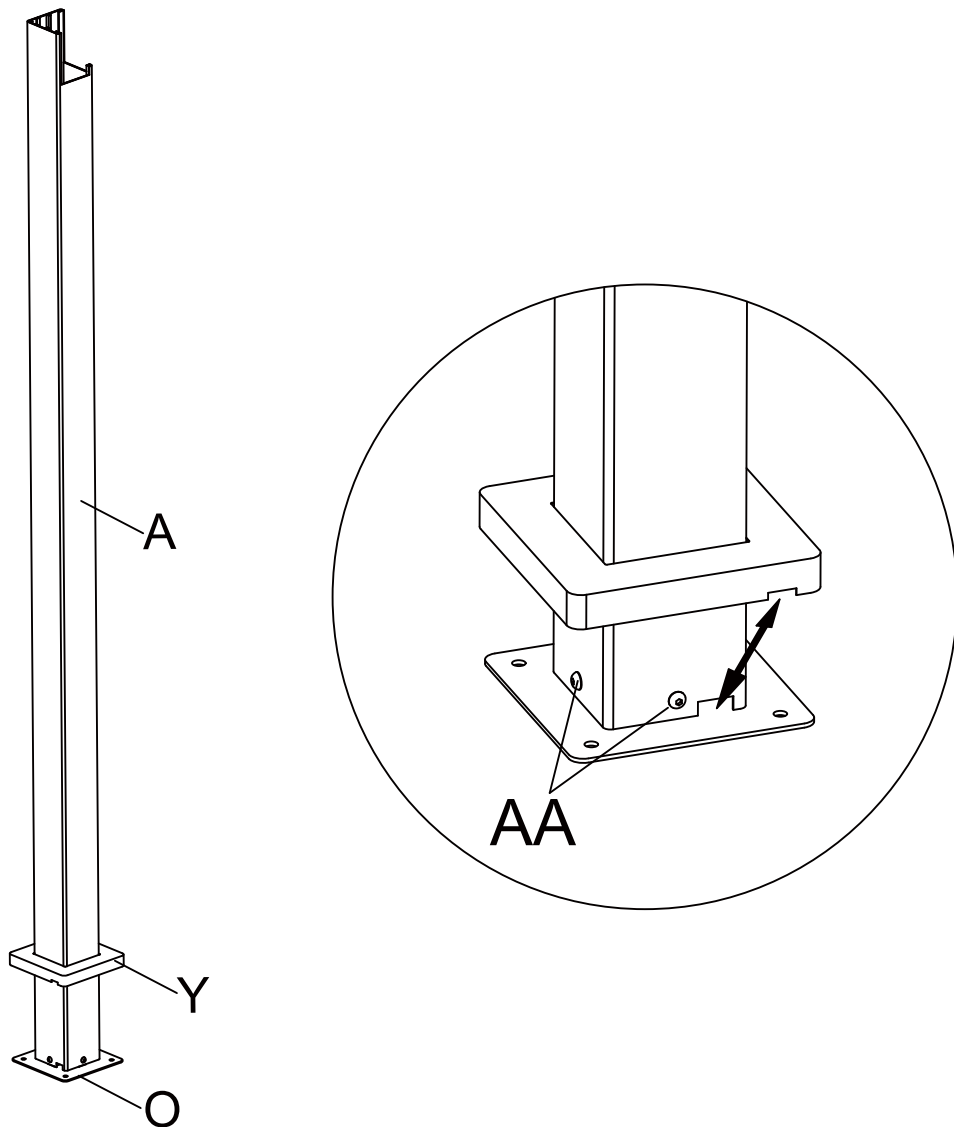

Put the corner post plate #Y into the corner post #A.  
Use 4 screws #AA to fix the post ground plate #O.  
Please complete the installation of 4 posts.

Part number	Qty	Part	Part number	Qty	Part
A	4		Y	4	
O	4		AA	16	 M6*18

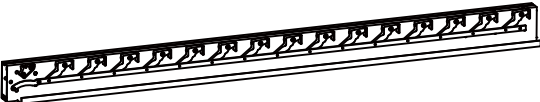

# STEP 2

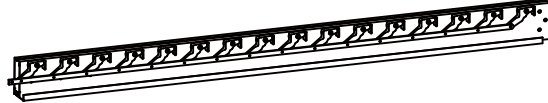

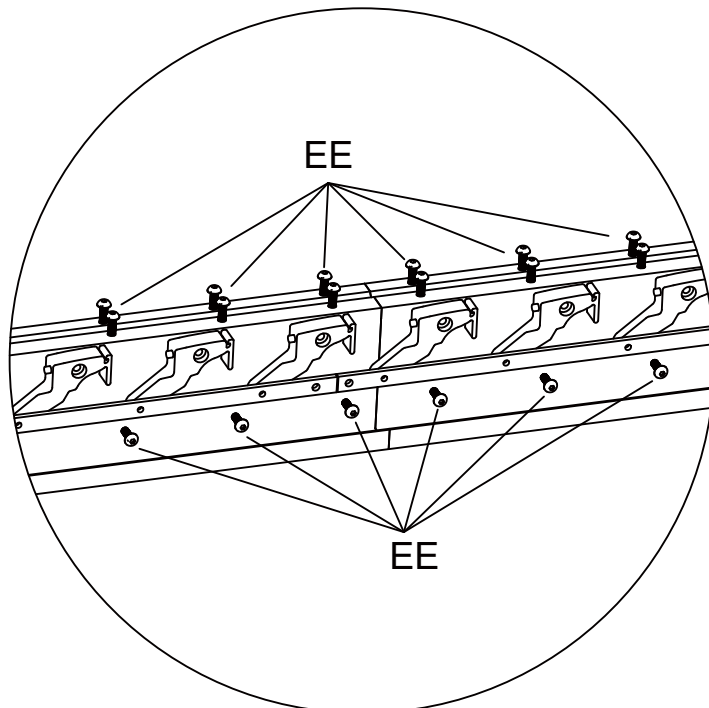
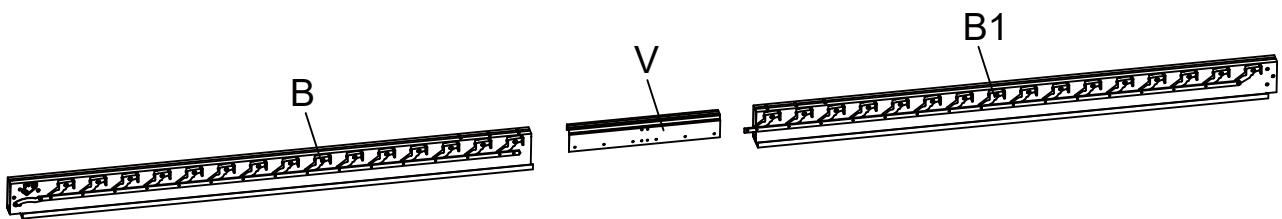

Use beam connector part #V to connect #BB1  
Then use screws #EE to fix the beam #BB1

Part number	Qty	Part	Part number	Qty	Part
B	1		V	1	
B1	1		EE	18	 M6*10

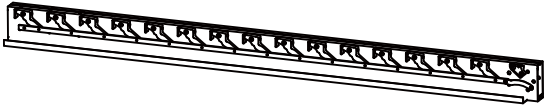

# STEP 3

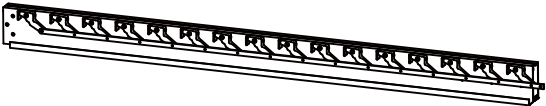

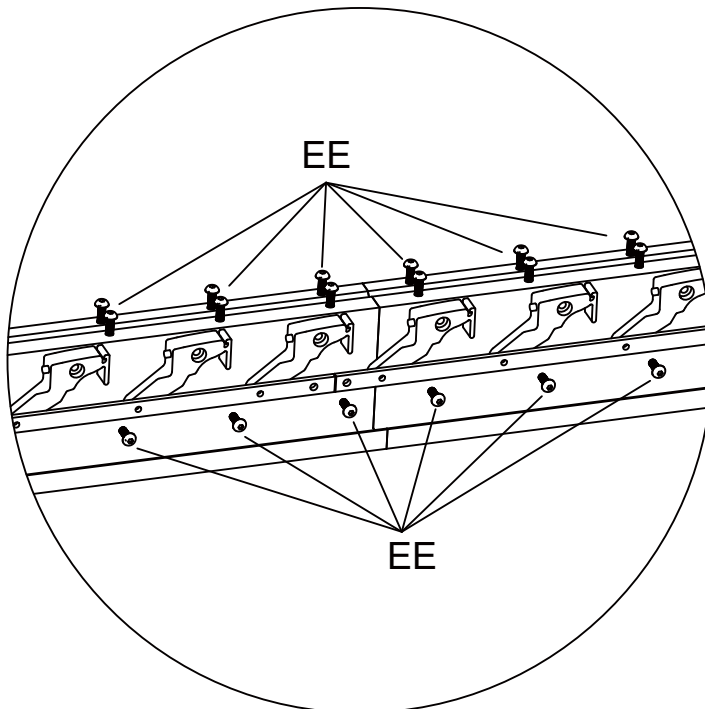
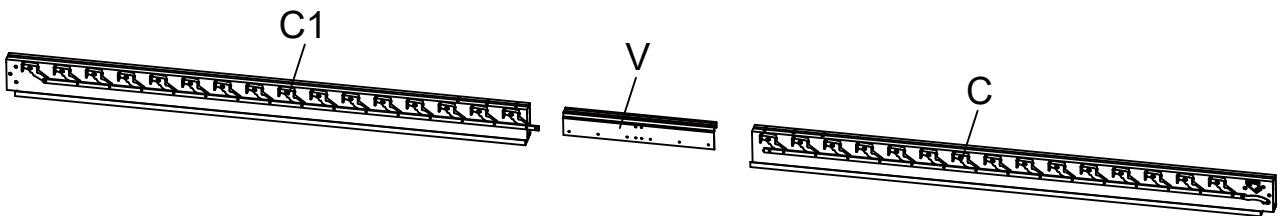

Use beam connector part #V to connect #CC1  
Then use screws #EE to fix the beam #CC1

Part number	Qty	Part	Part number	Qty	Part
C	1		V	1	
C1	1		EE	18	 M6*10

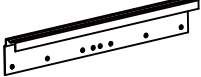

# STEP 4

Use beam connector part #V to connect #EE1  
 Then use screws #EE to fix the beam #EE1, use screws #BB  
 to fix the part #L



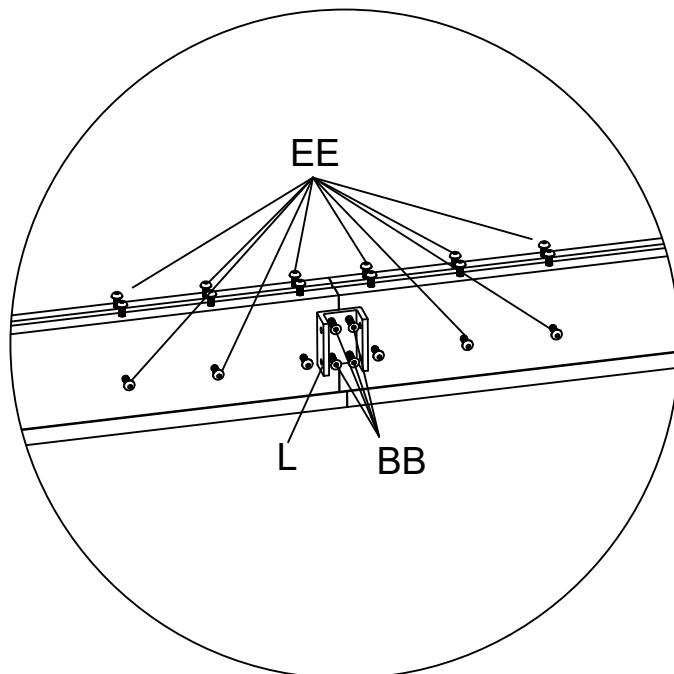
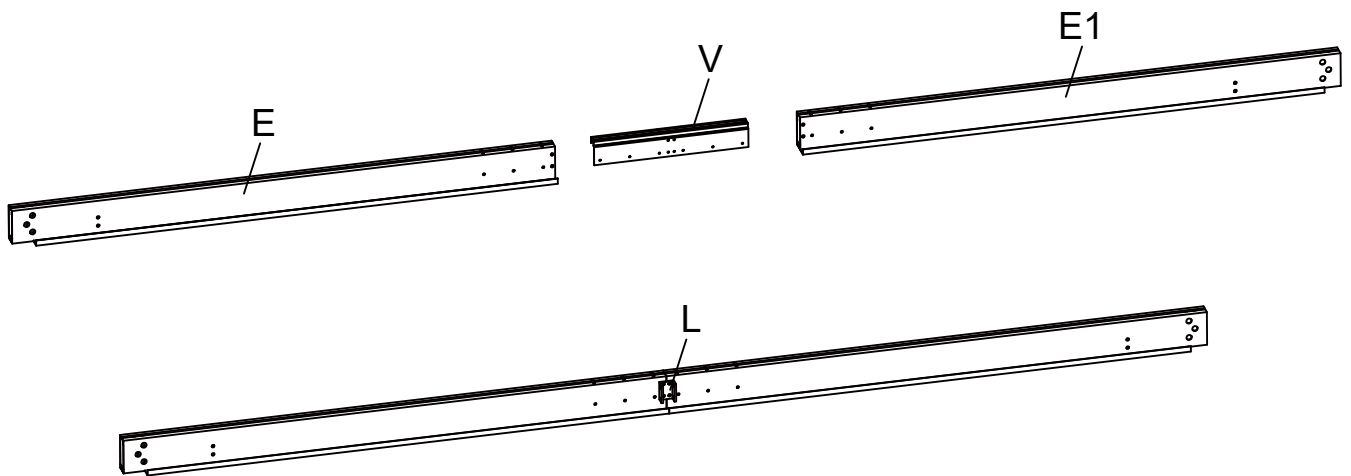

Part number	Qty	Part	Part number	Qty	Part
E	1		V	1	
E1	1		BB	4	 M6*15
L	1		EE	18	 M6*10

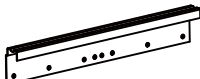

# STEP 5

Use beam connector part #V to connect #E2E3

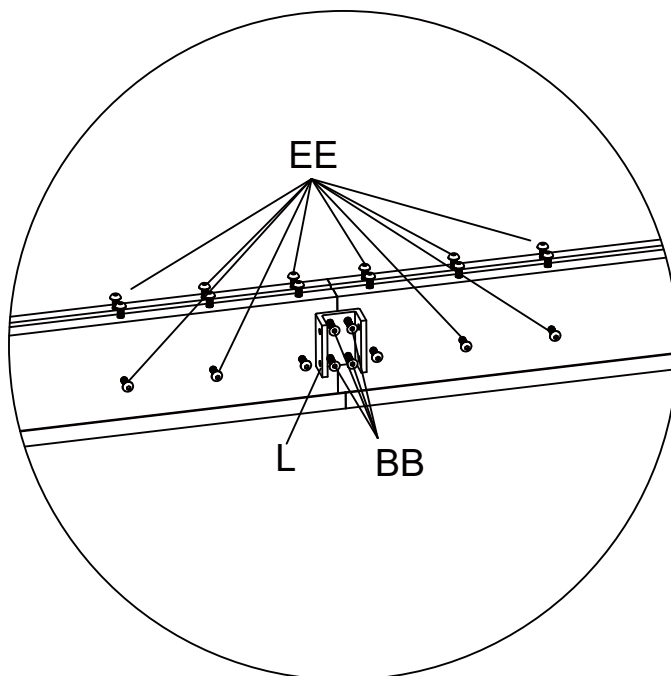
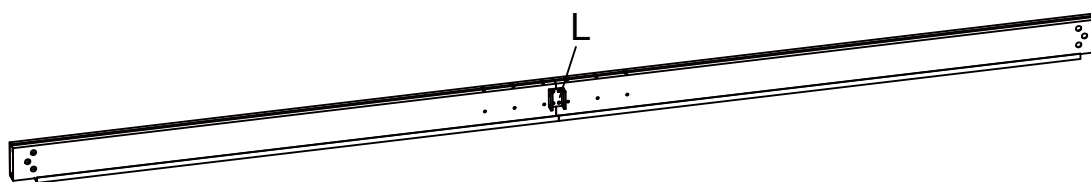
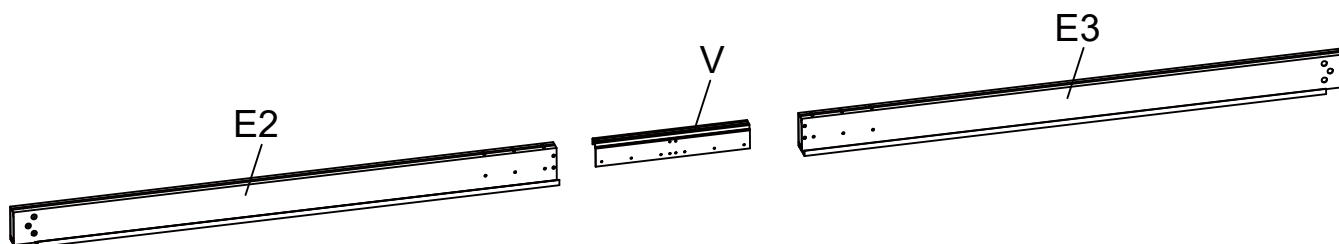

Then use screws #EE to fix the beam #E2E3, use screws #BB to fix the part #L

Part number	Qty	Part	Part number	Qty	Part
E2	1		V	1	
E3	1		BB	4	 M6*15
L	1		EE	18	 M6*10

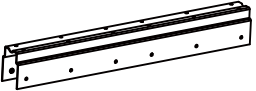

# STEP 6

Use beam connector part #W to connect middle beam #DD1  
Then use screws #EE to fix the middle beam #DD1

Part number	Qty	Part	Part number	Qty	Part
D	1		W	1	
D1	1		EE	24	 M6*10

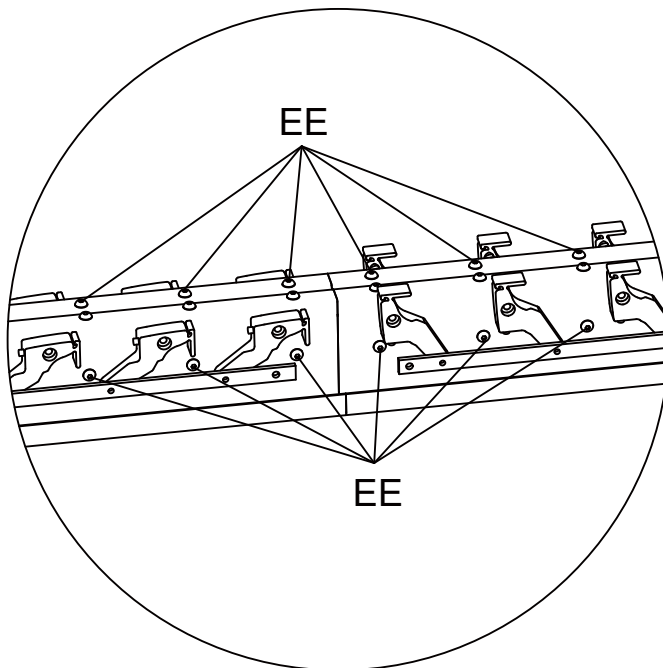
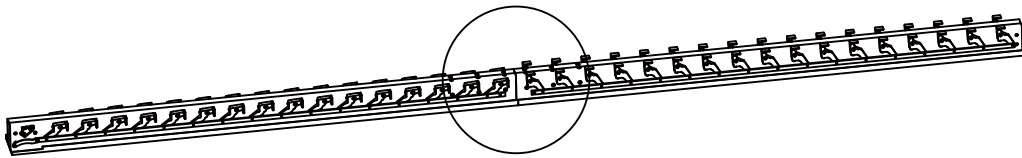
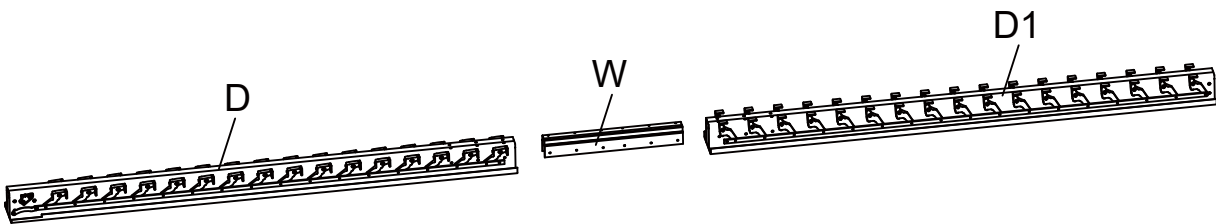

# STEP 7

Slide the beam #EE1 into the grooves of the post #A in such a way that the slot nuts of the end beam #EE1 interlock with the slots in the post #A. Additional people are needed to help hold the beams

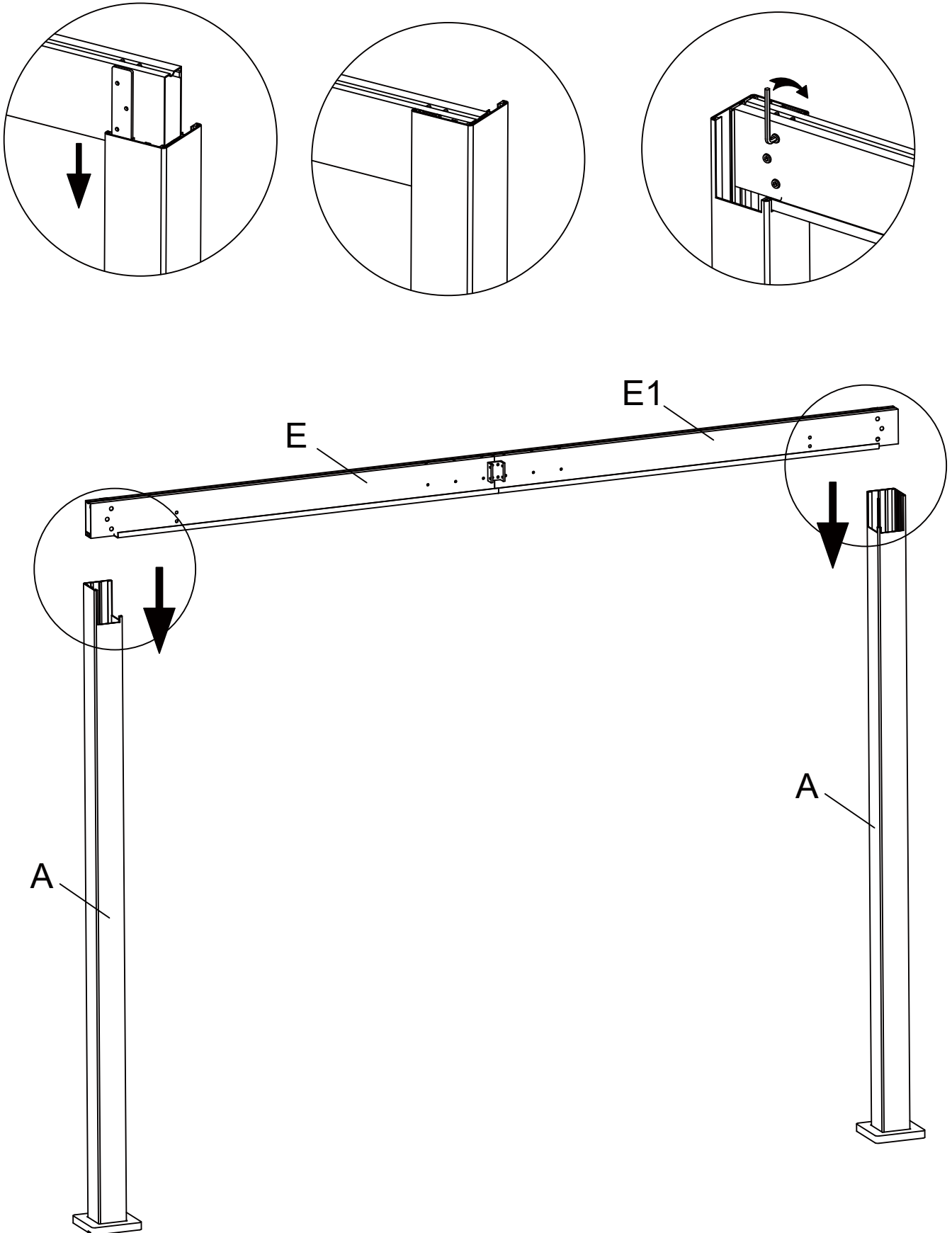

# STEP 8

Slide the beam #E2E3 into the grooves of the post #A in such a way that the slot nuts of the end beam #E2E3 interlock with the slots in the post #A.

Additional people are needed to help hold the beams

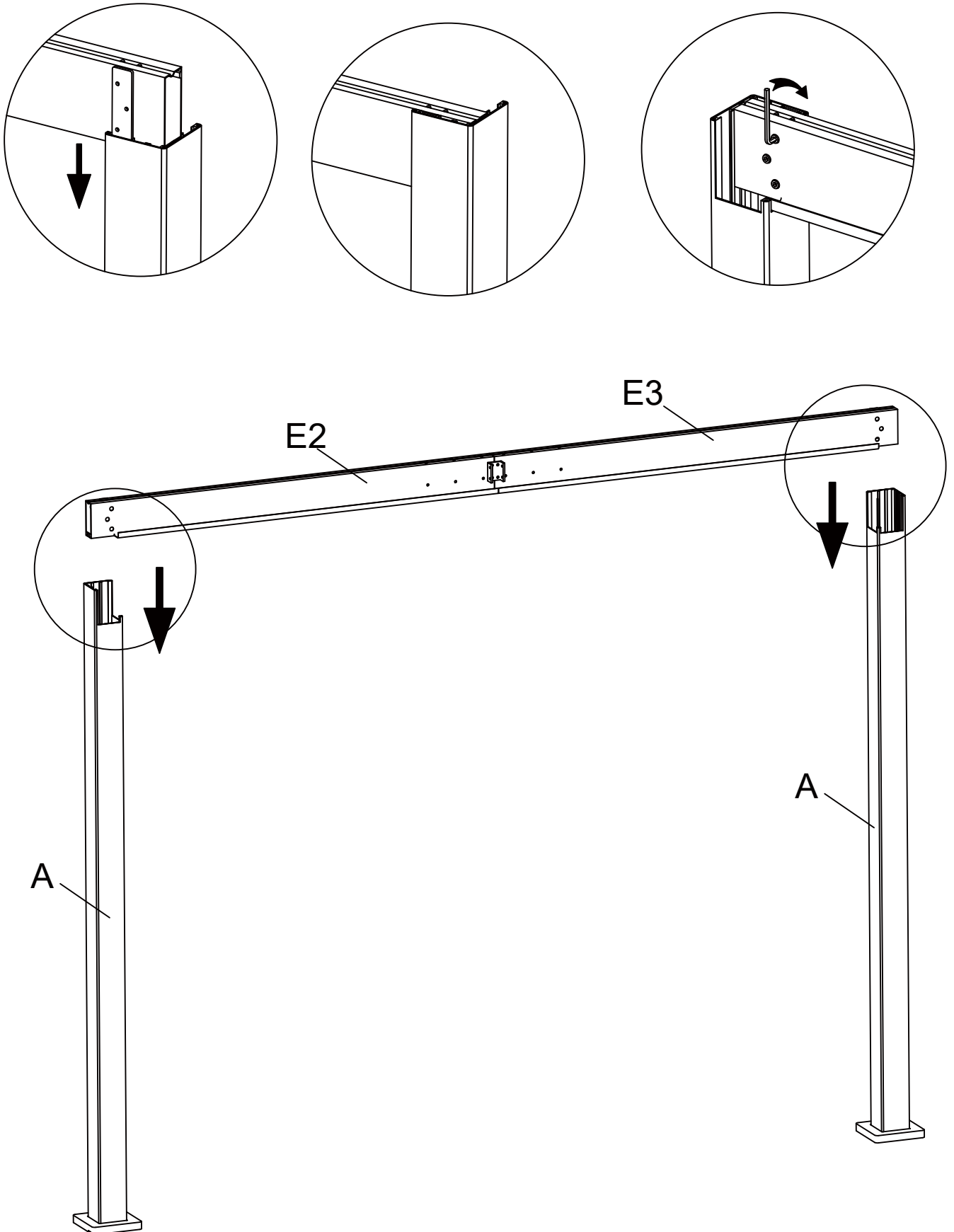

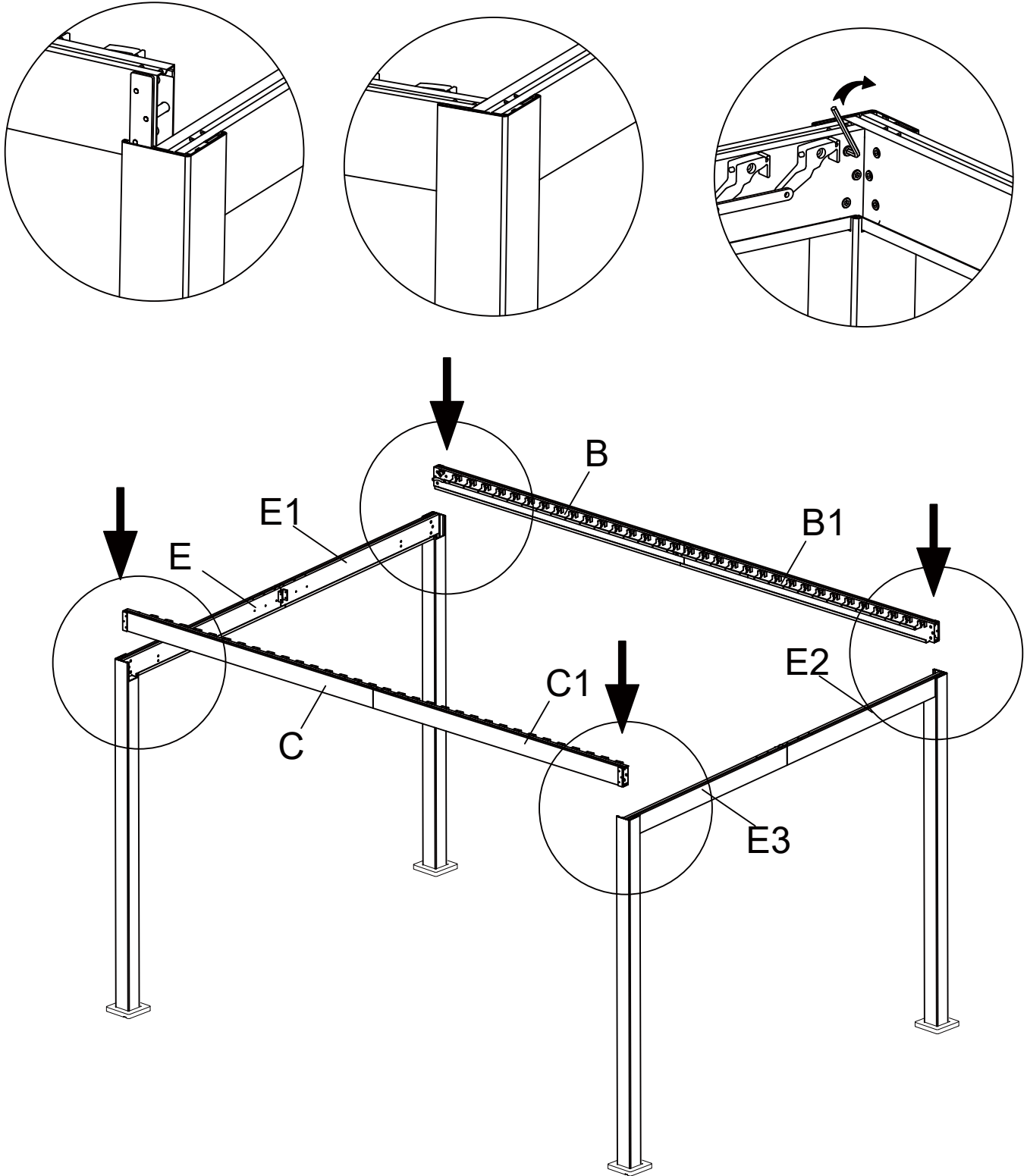

# STEP 9

Connect a side beam #BB1(CC1) with the corner post #EE1(E2E3)  
Additional people are needed to help hold the beams



# STEP 10

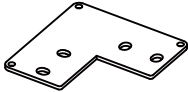

Fix the post covers to the top of each corner post with screws #AA #HH

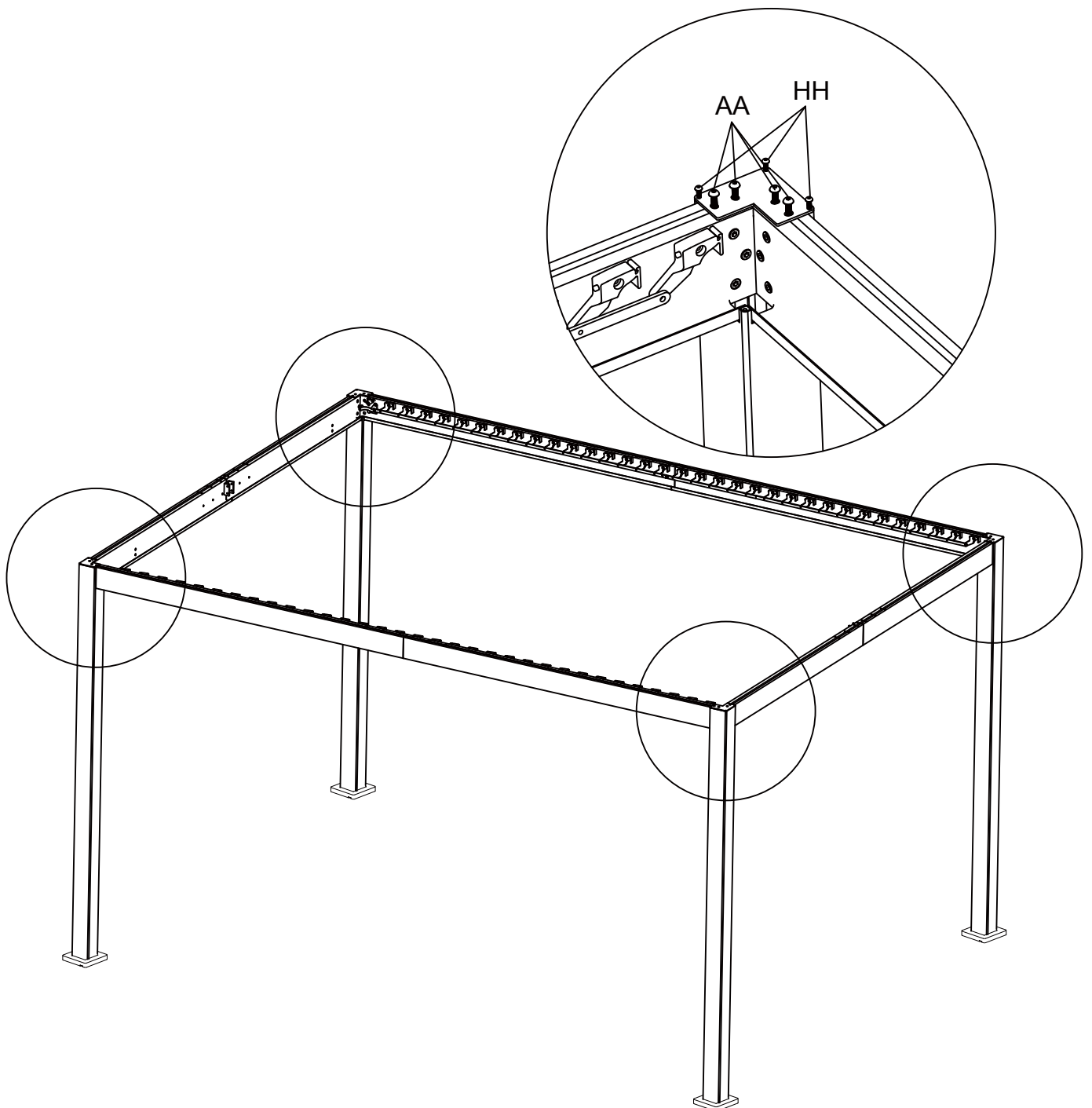
Part number	Qty	Part	Part number	Qty	Part
K	1		AA	16	 M6*18
HH	12	 M5*12			



# STEP 11

Apply Sealing glue to the gaps between the beams, Then use glue to stick the #S in the picture position.

Part number	Qty	Part			
S	4		X	1	

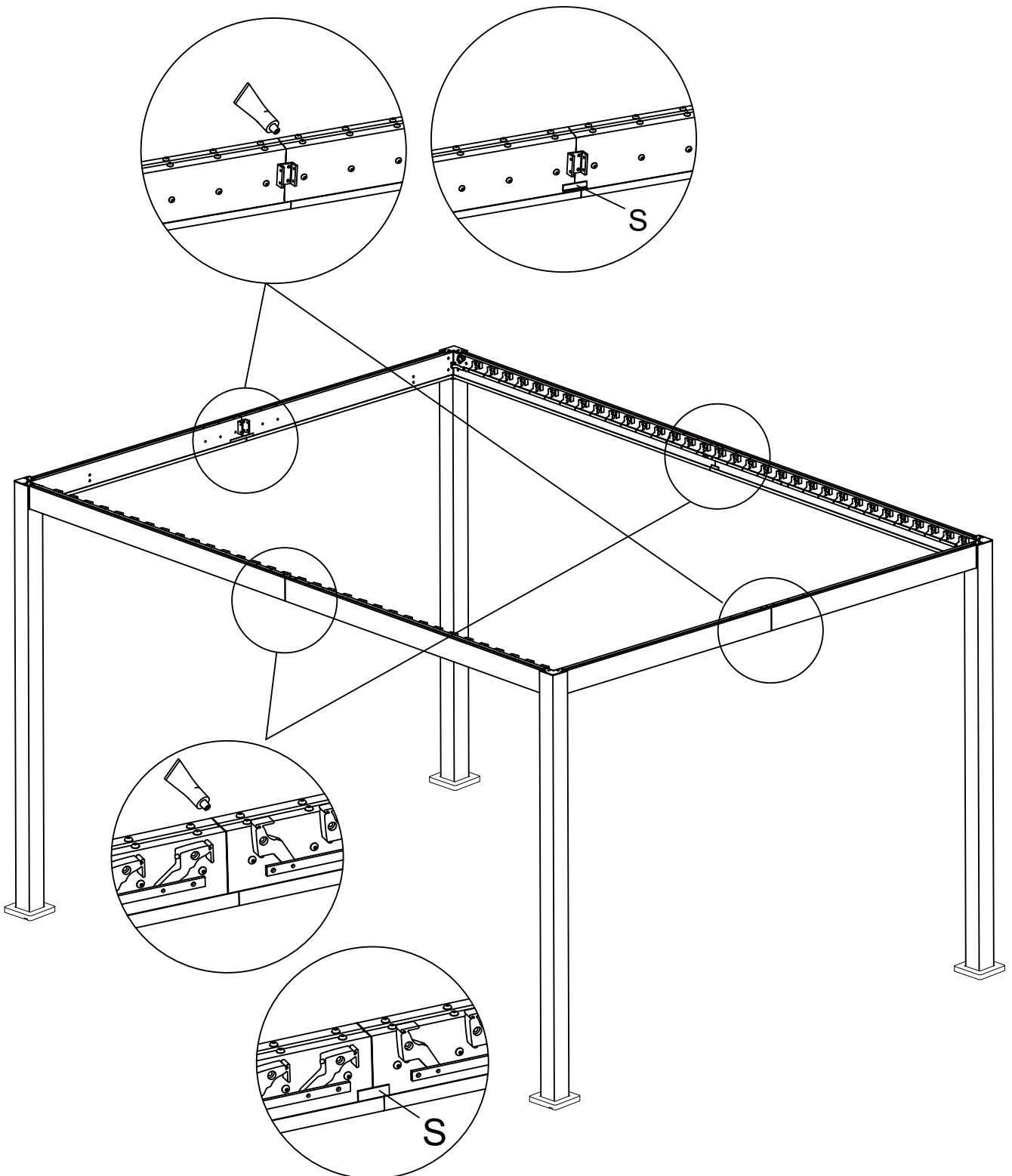

# STEP 12

Install the middle beam and fix both sides with screws #AA.

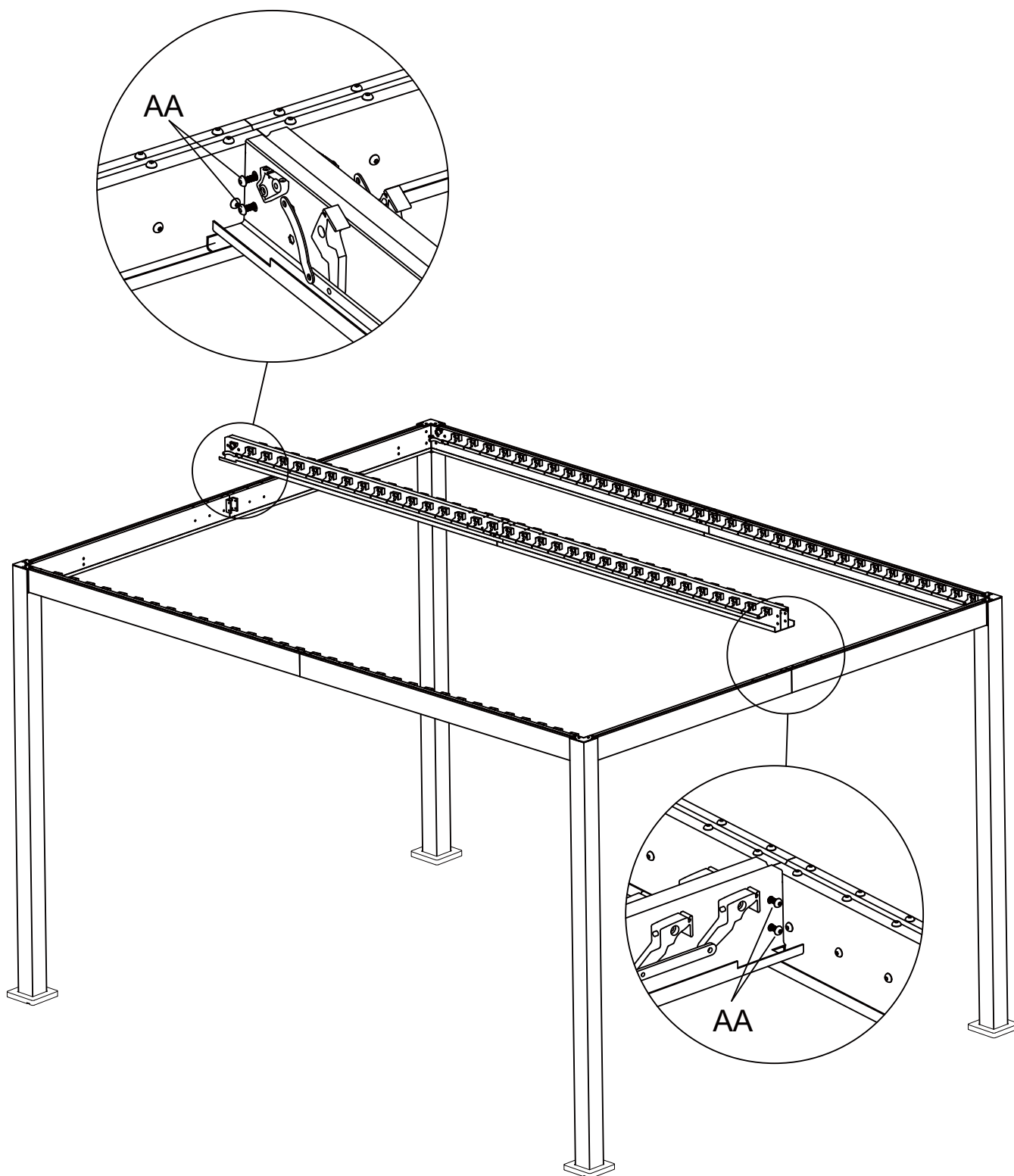

Part number	Qty	Part
AA	8	 M6*18



# STEP 13

Apply Sealing glue to the gaps between the beams, Then use glue to stick the #T in the picture position.





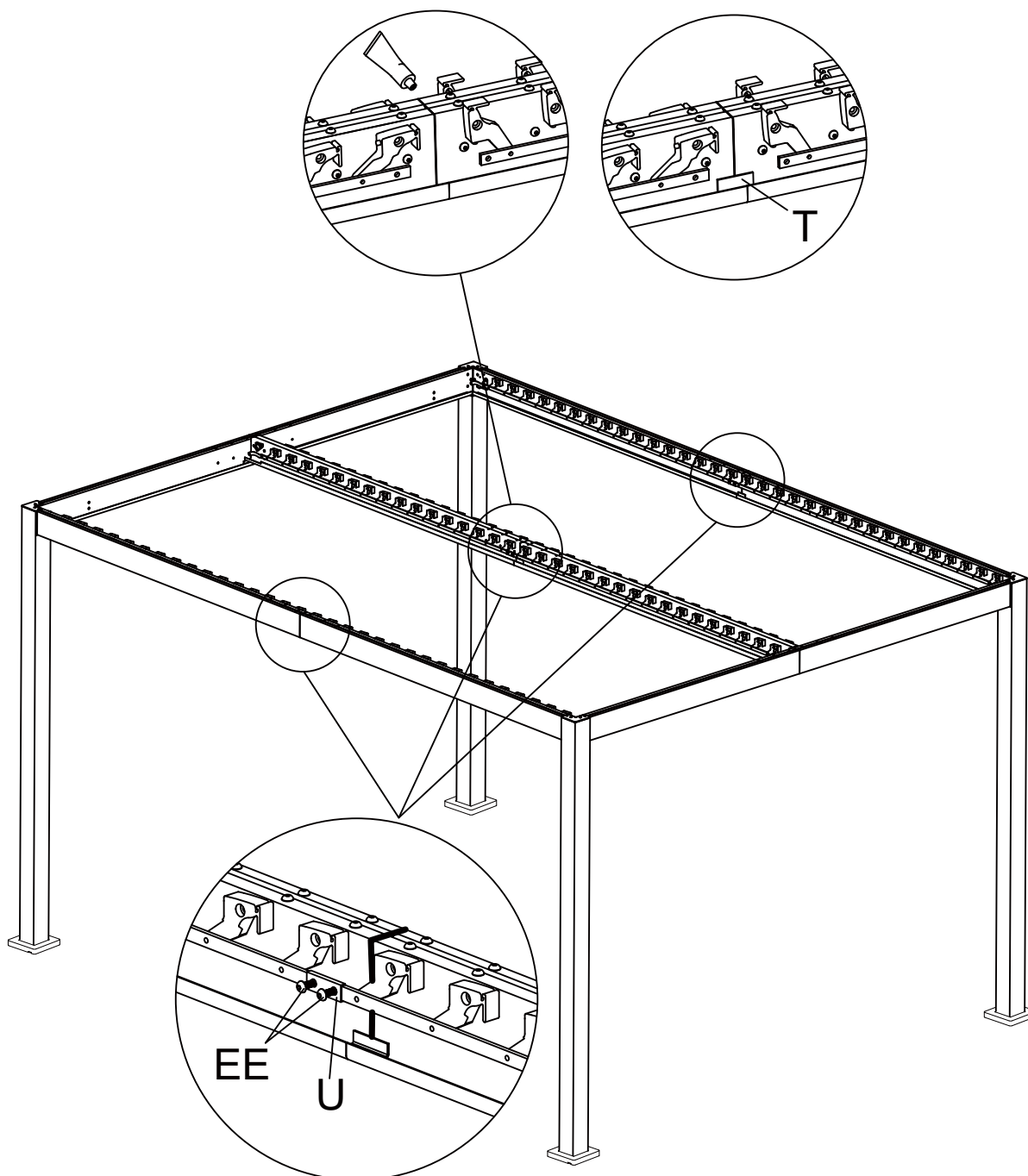



Part #U needs to be fixed to the beam with screws #EE.

Part number	Qty	Part			
T	2		EE	8	 M6*10
U	4				

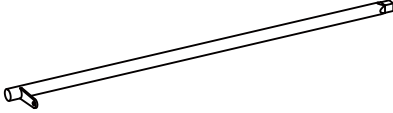

# STEP 14



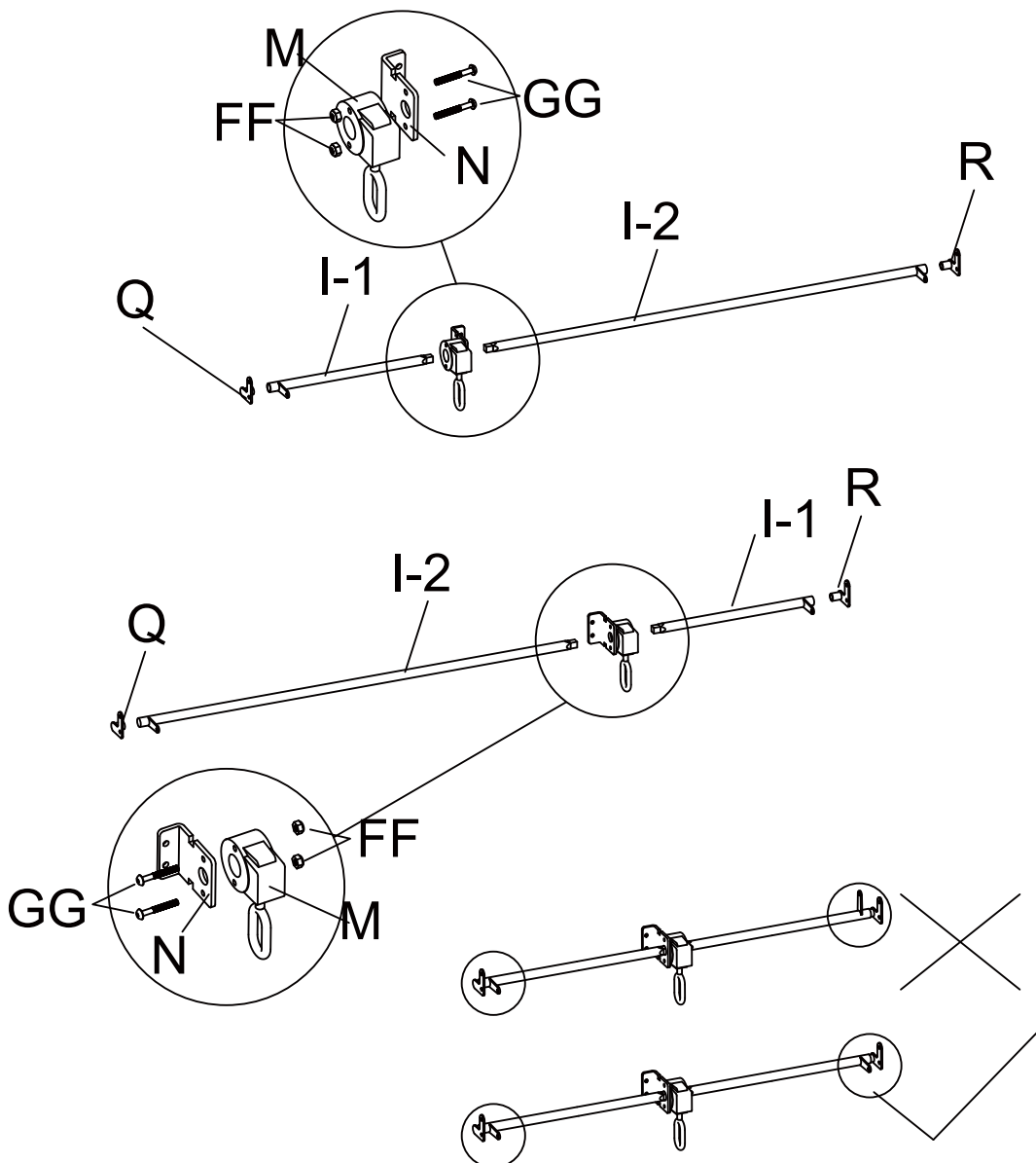

Install Gear Crossbar, Pay attention to the need to put it in the correct position (as the picture show)

Part number	Qty	Part	Part number	Qty	Part
I-1	2		M	2	
I-2	2		N	2	
Q	2		FF	4	 M6
R	2		GG	4	 M6*40



# STEP 15

Use screws #AA #BB #CC to fix Gear Crossbar  
(as the picture show)

Part number	Qty	Part	Part number	Qty	Part
AA	4	 M6*18	BB	8	 M6*15
CC	4	 M6*13	FF	4	 M6

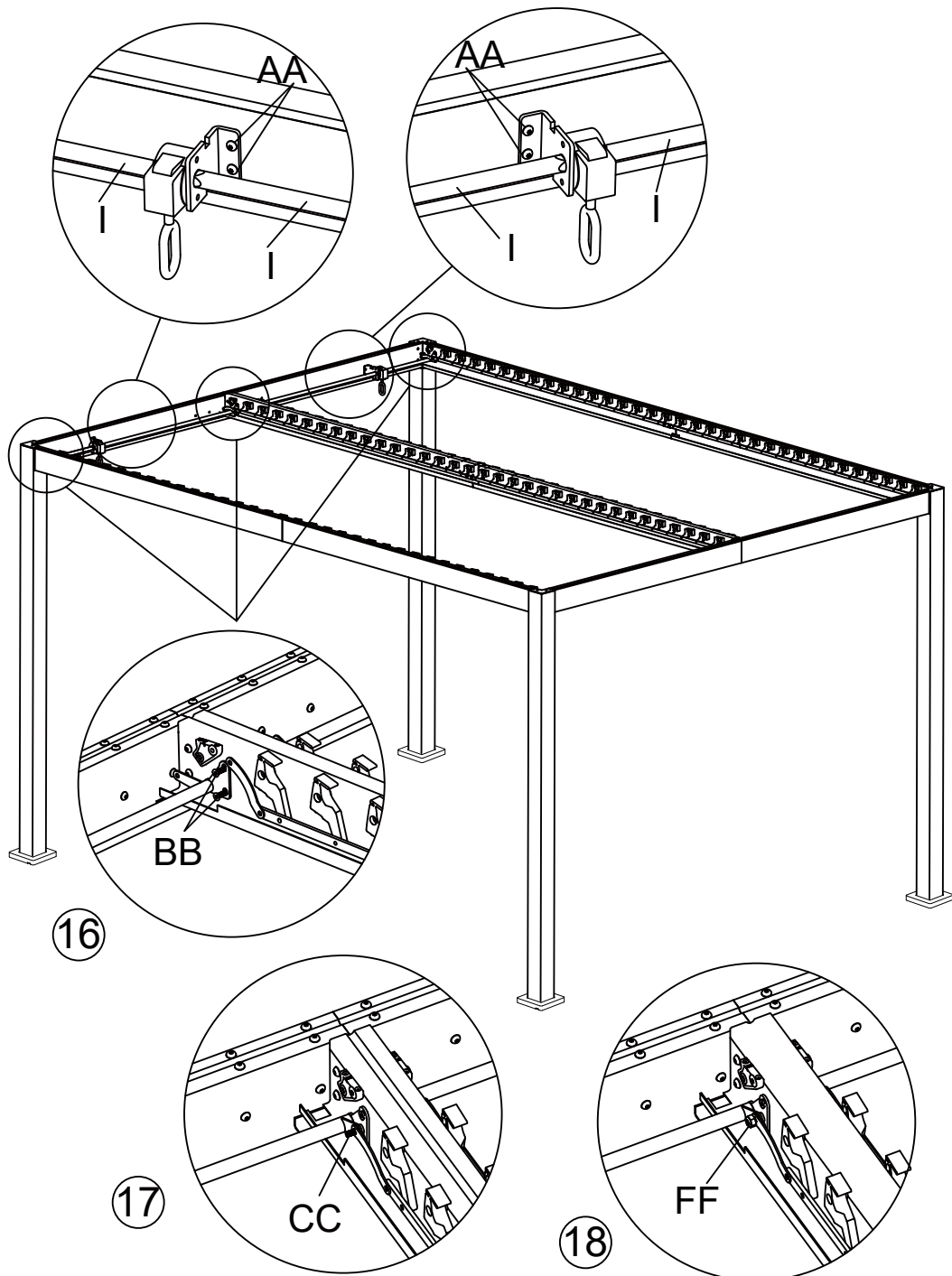

# STEP 16

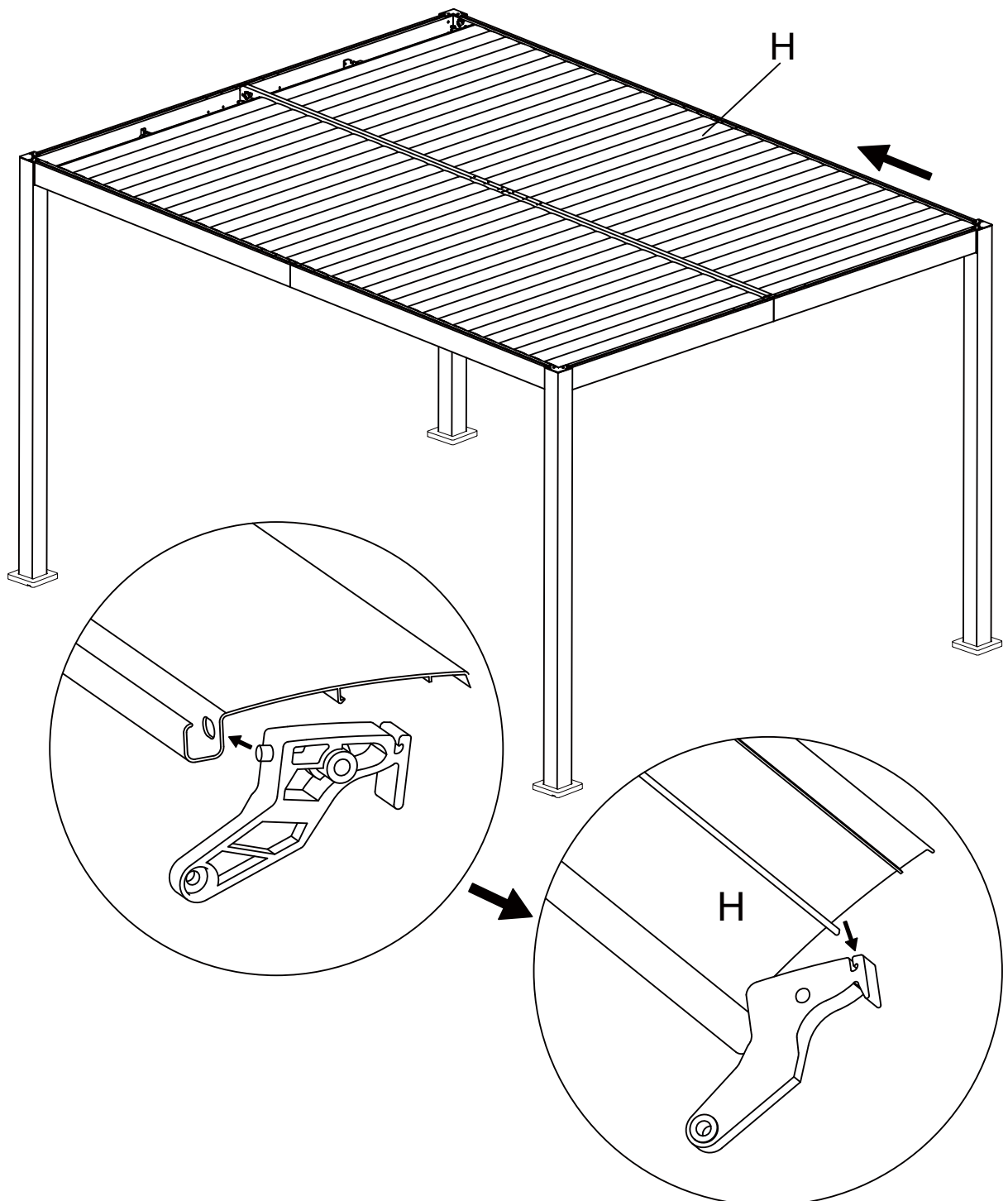

Snap the louvers into the connectors on both sides. Pay attention to the need to put it in the correct position (as the picture show)

Part number	Qty	Part
H	66	



# STEP 17

Attach louvers #G with screws #DD. (as the picture show)

Part number	Qty	Part	Part number	Qty	Part
G	2		DD	4	 M4*12

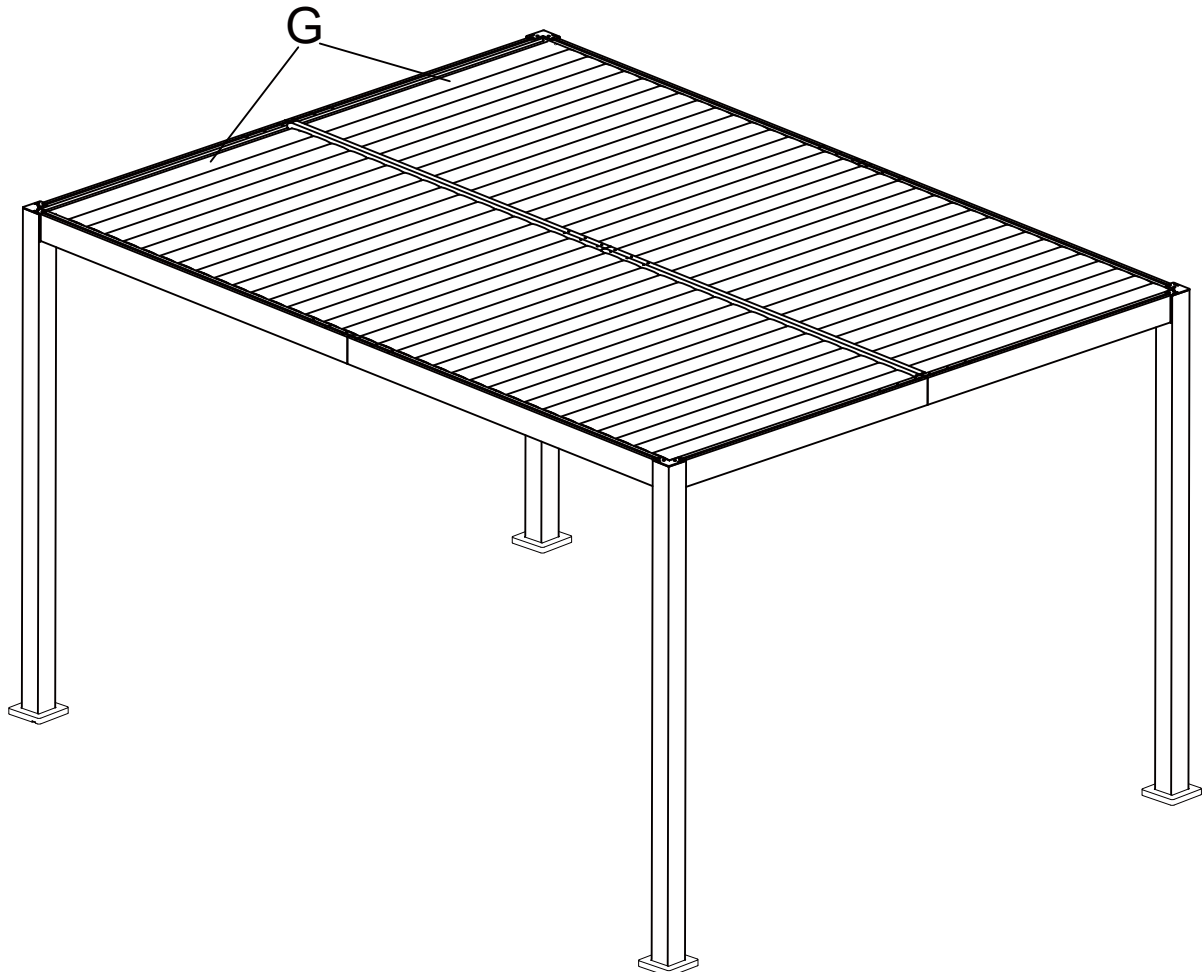
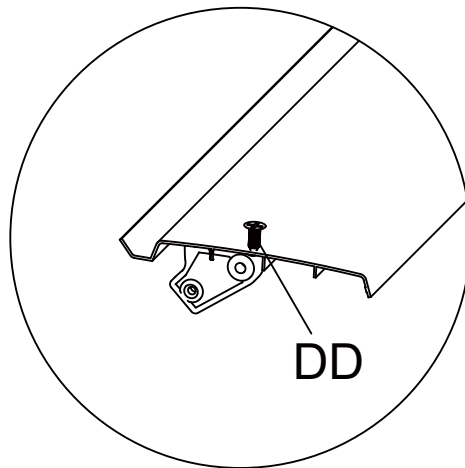

# STEP 18

Peel off the sticker behind F and stick it on the middle of the middle beam.

Then peel off the sticker on the back of F1 and stick it on the middle of the long and short beams around it.

(as the picture show)

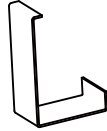
F	1		F1	4	
---	---	---	----	---	---

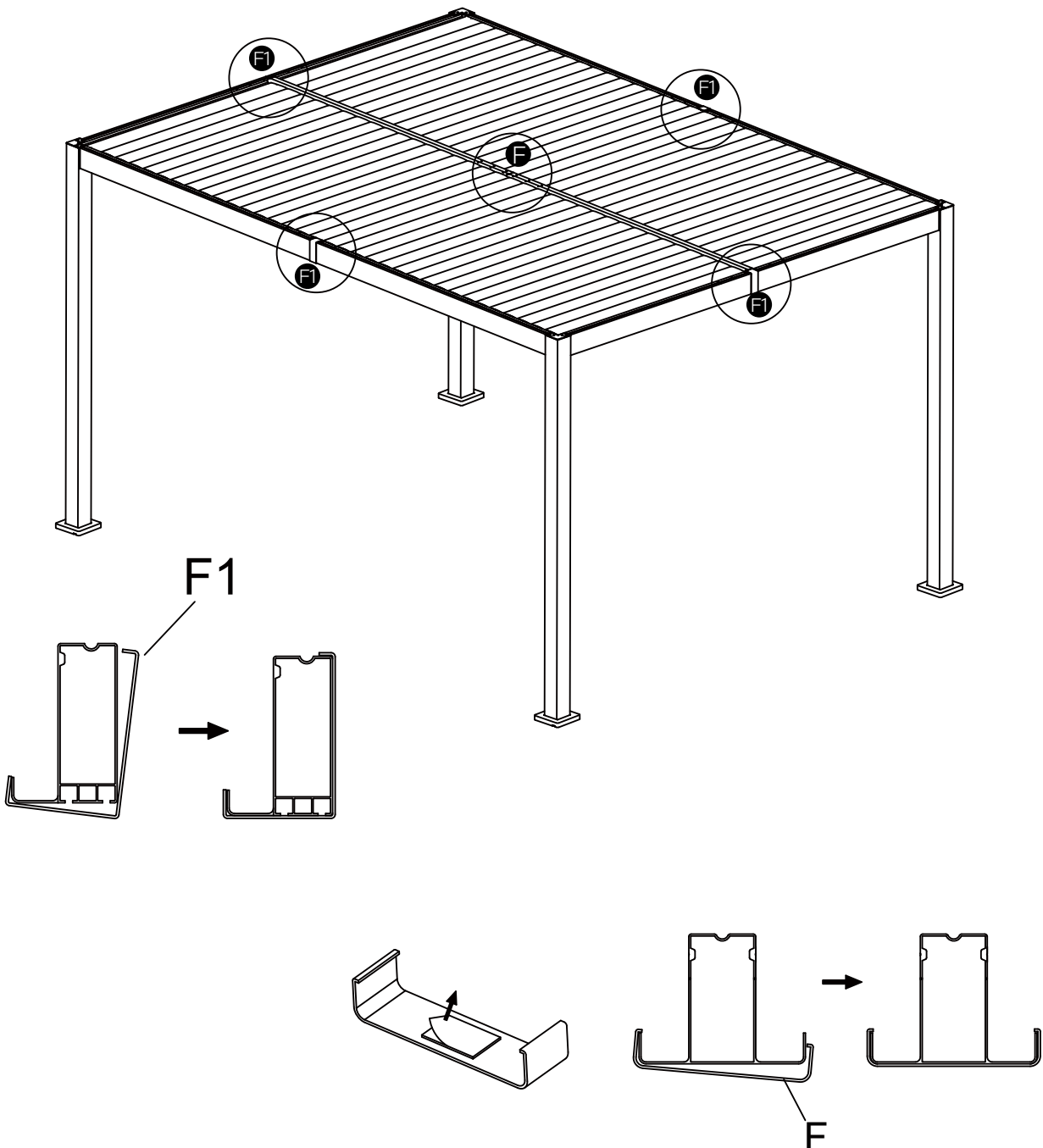

# STEP 19

Install expansions floor nails

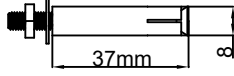
MM	16		M6*50
----	----	---	-------

