

Assembly Instructions

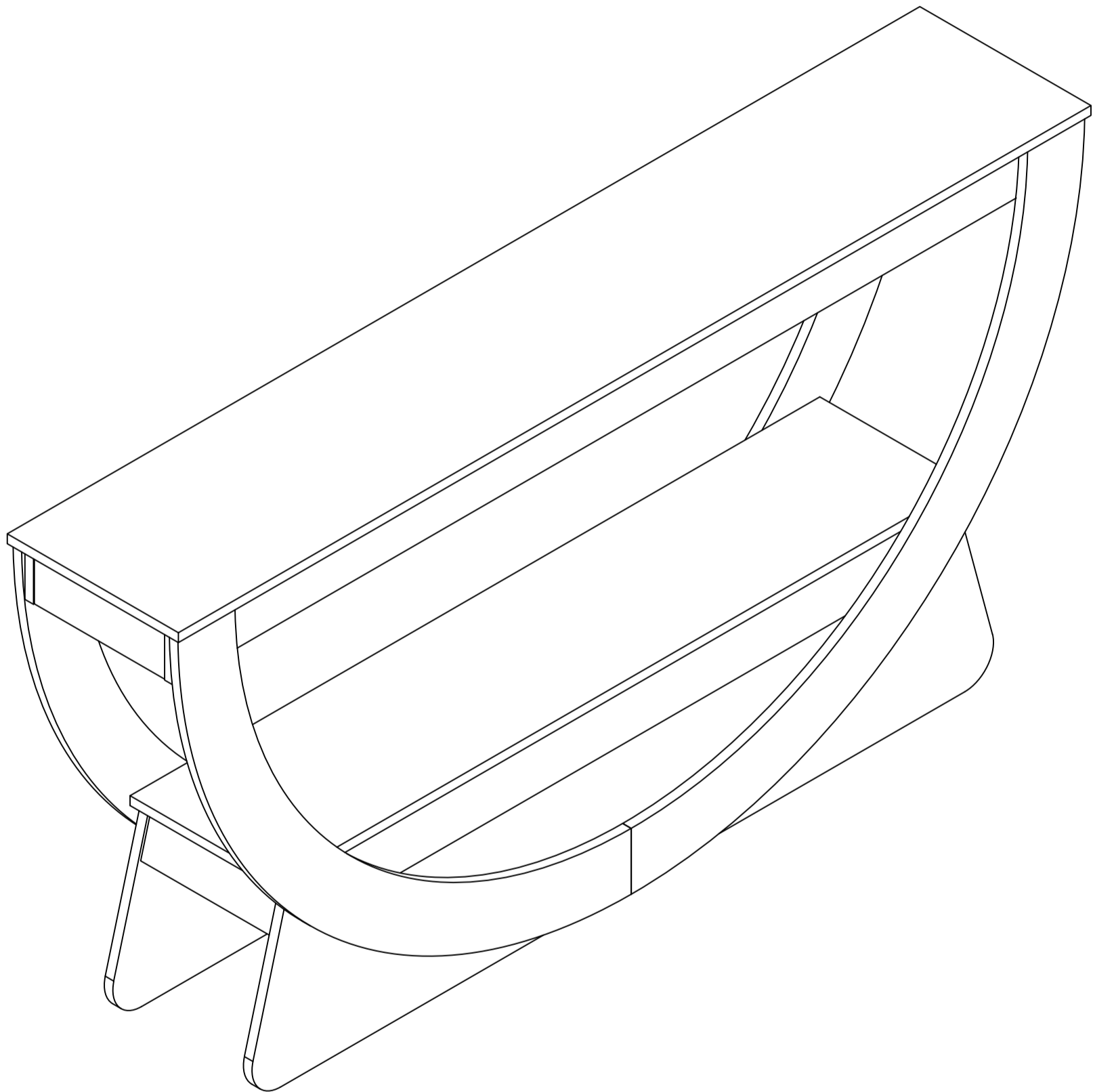

Console Table

Contact Us

We're here to help you.

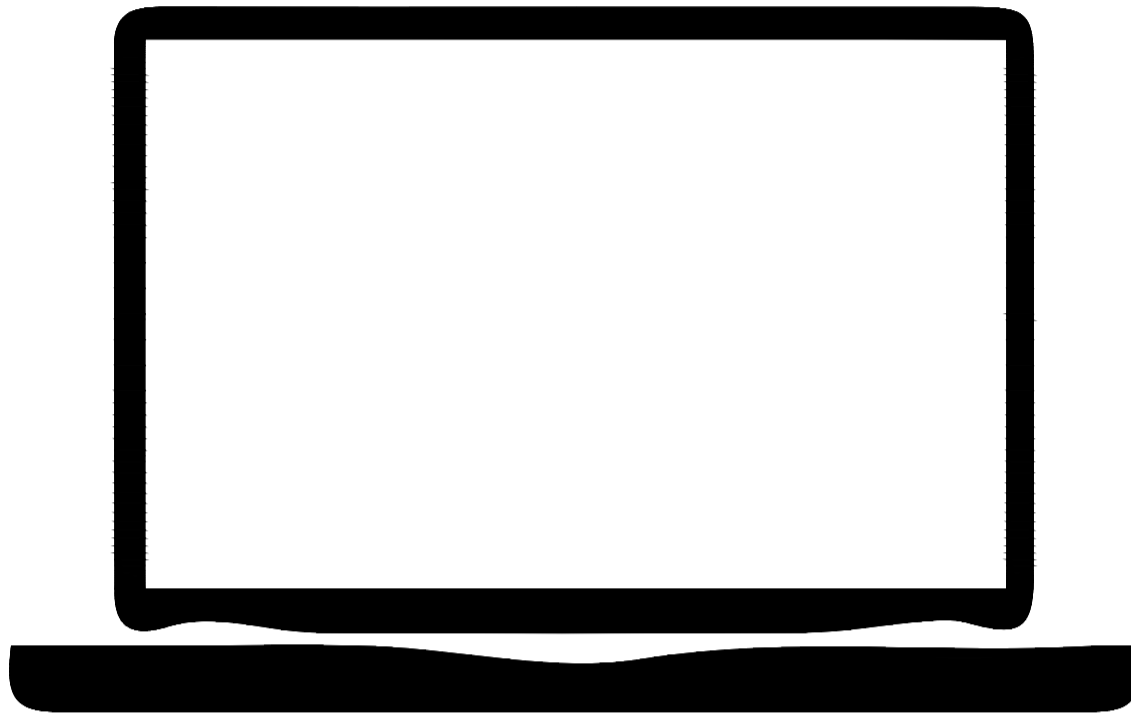

Your satisfaction is our top priority. If you encounter any issues with this product, such as missing or damaged parts, we're here to help. Please retain the original packaging and take photos of the packaging and the product, then contact us as soon as possible.

Warm Tips

1. Carefully read these instructions and keep them for future reference.
2. Check the parts list and confirm everything's there before starting assembly.
3. When assembling, put all parts on a soft, smooth surface like a carpet to avoid scratches.
4. Don't fully tighten screws until all parts are confirmed in place to avoid misalignment.

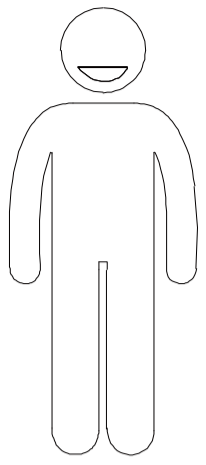

X2

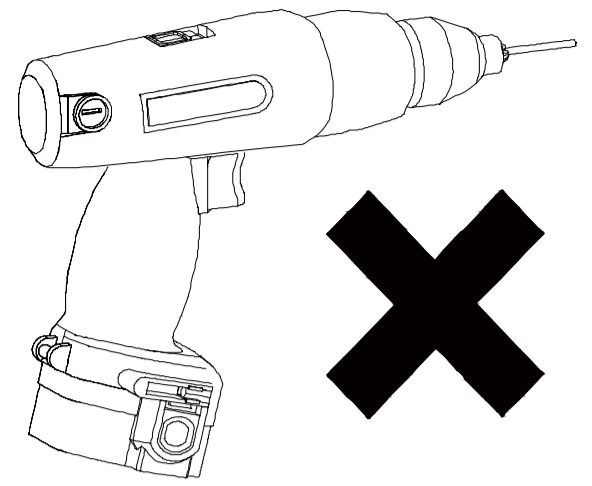
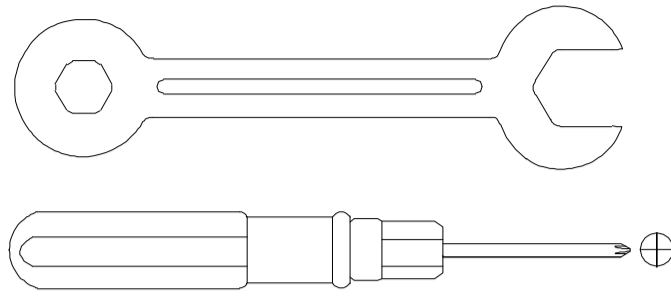

We recommend using hand tools for assembly.

If an electric screwdriver is used, reduce power and torque to avoid damage to the product.

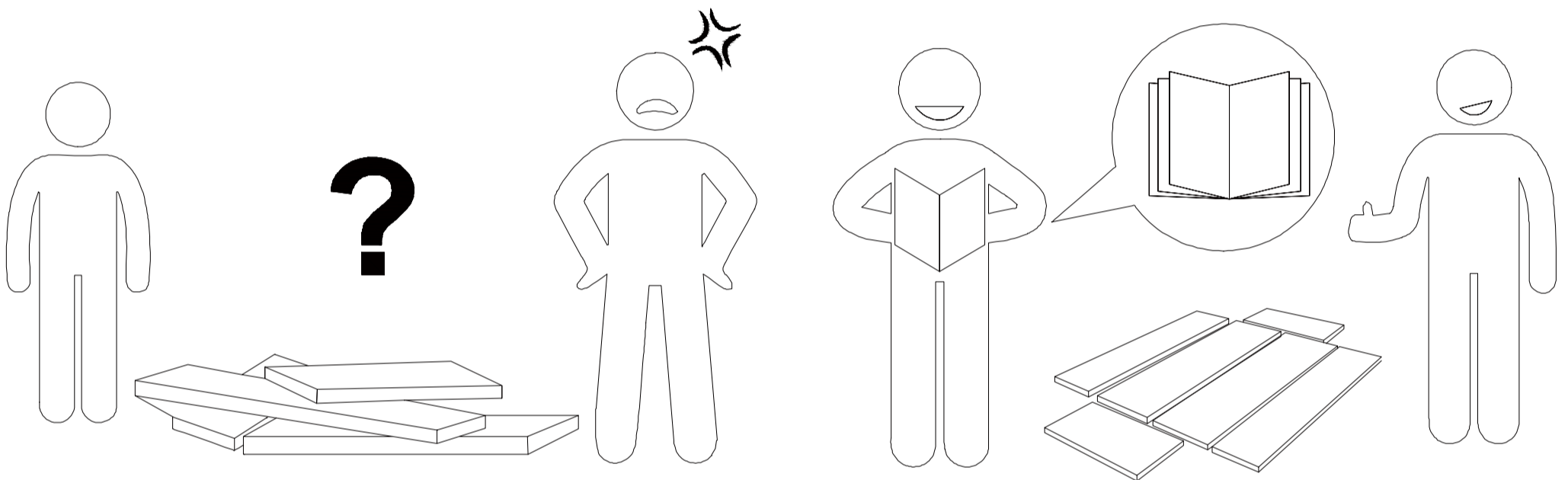

Install the Anti-Tip Straps

Using the anti-tip straps can reduce the risk of tipping over, but can not eliminate it.

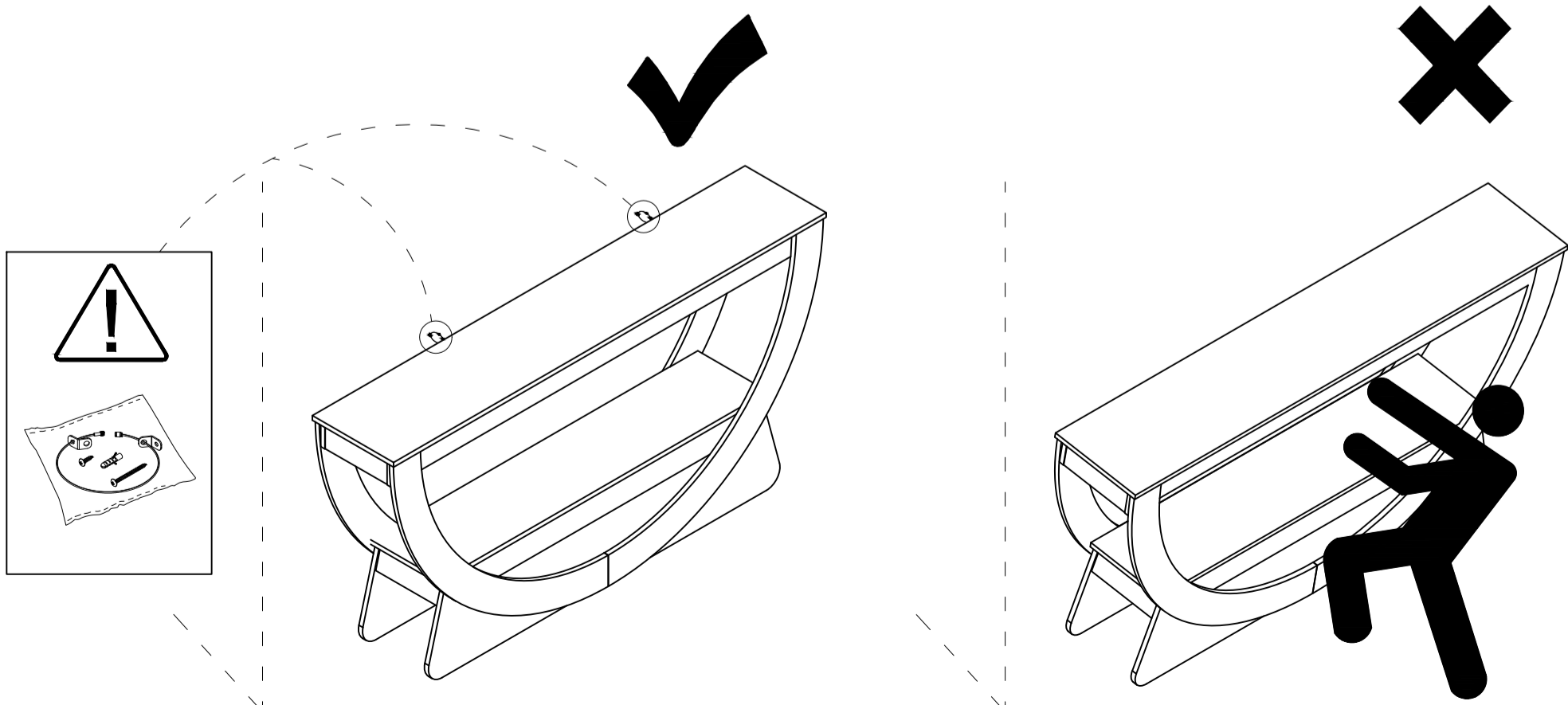

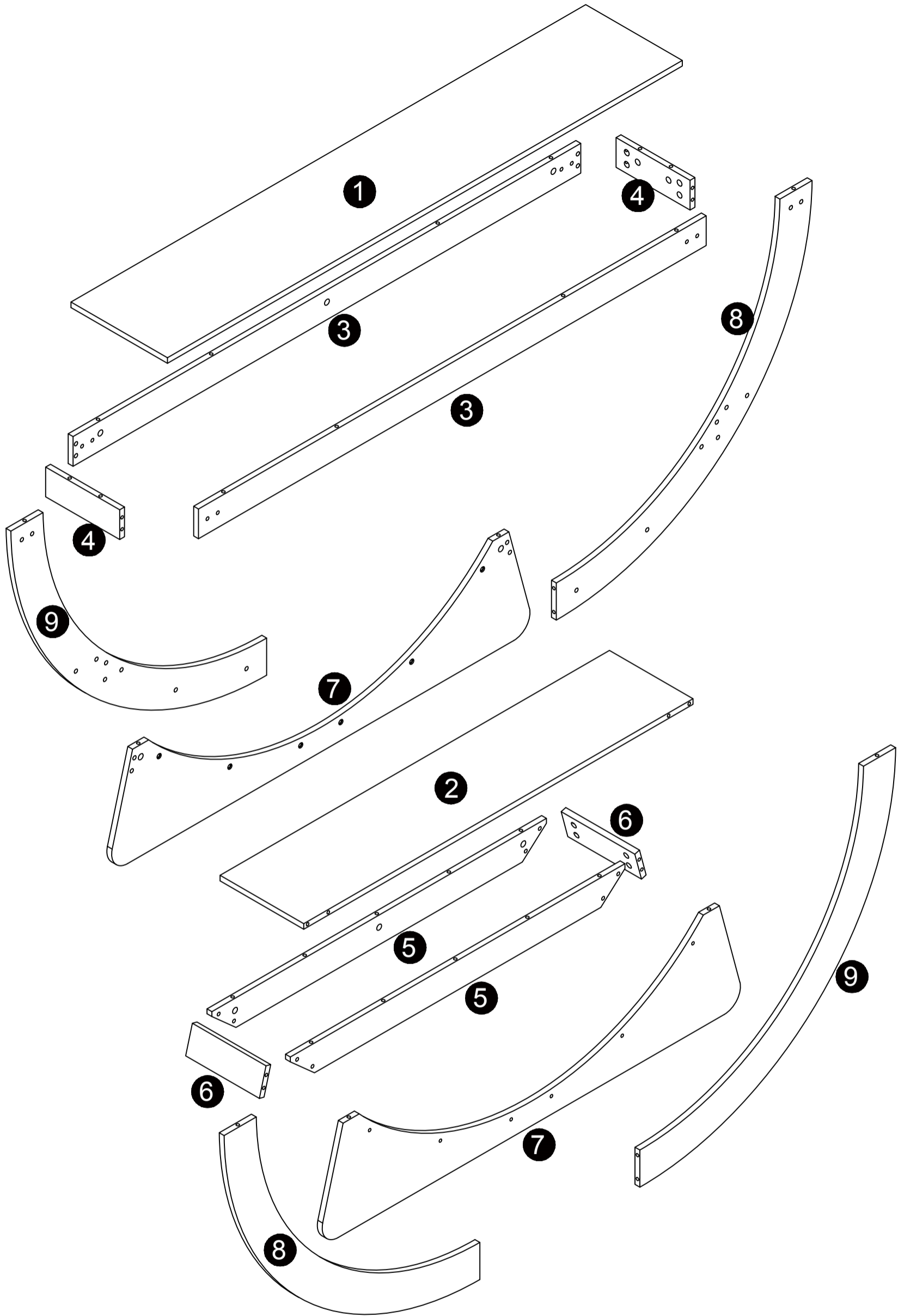



⚠ Caution

Make sure all parts are included. Most board parts are labeled or stamped on the raw edge. Contact us for a free replacement if you encounter any damaged or missing parts.

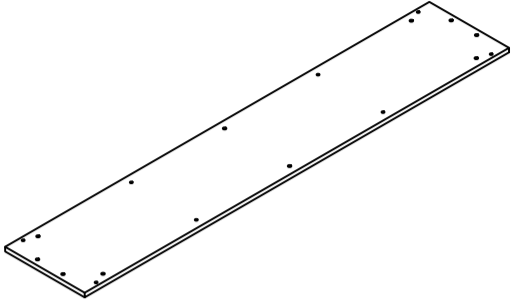
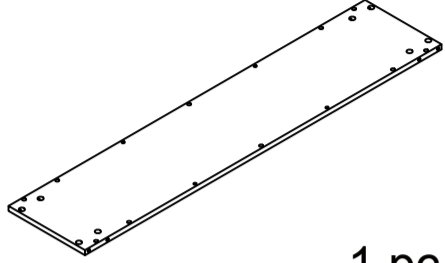
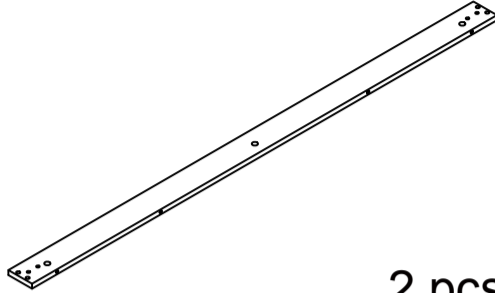
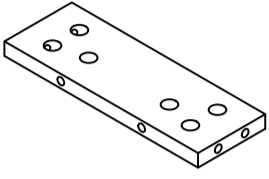
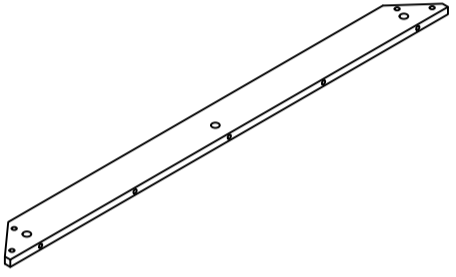
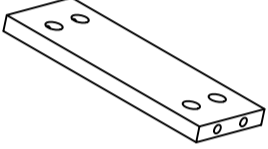
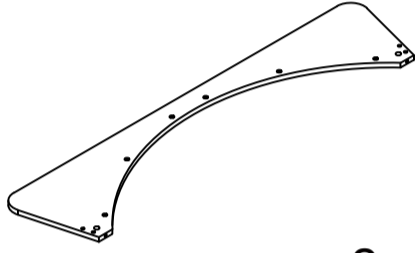
Parts List

<p>1</p>  <p>1 pc</p>	<p>2</p>  <p>1 pc</p>	<p>3</p>  <p>2 pcs</p>	<p>4</p>  <p>2 pcs</p>
<p>5</p>  <p>2 pcs</p>	<p>6</p>  <p>2 pcs</p>	<p>7</p>  <p>2 pcs</p>	<p>8</p>  <p>2 pcs</p>
<p>9</p>  <p>2 pcs</p>			

Hardware List

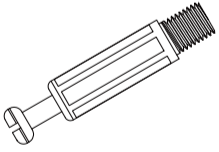
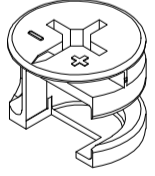
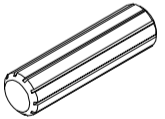
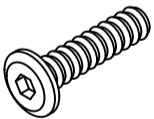
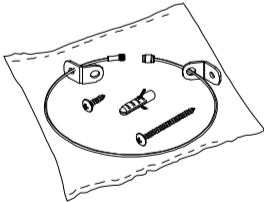
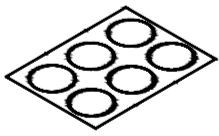
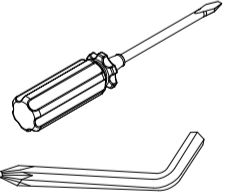
A	B	C	D	E	F	G
 <p>M6x40mm</p>	 <p>Ø15x12mm</p>	 <p>Ø8x35mm</p>	 <p>M6x22mm</p>	 <p>2 pcs</p>	 <p>Ø20</p>	 <p>M4</p>
<p>44 pcs</p>	<p>44 pcs</p>	<p>16 pcs</p>	<p>28 pcs</p>	<p>2 pcs</p>	<p>30 pcs</p>	<p>1 pc</p>

Installation of Cams and Pins

Read each step carefully before starting. Each step of instruction should be performed in the correct order. If these steps are not followed in sequence, assembly difficulties may occur.

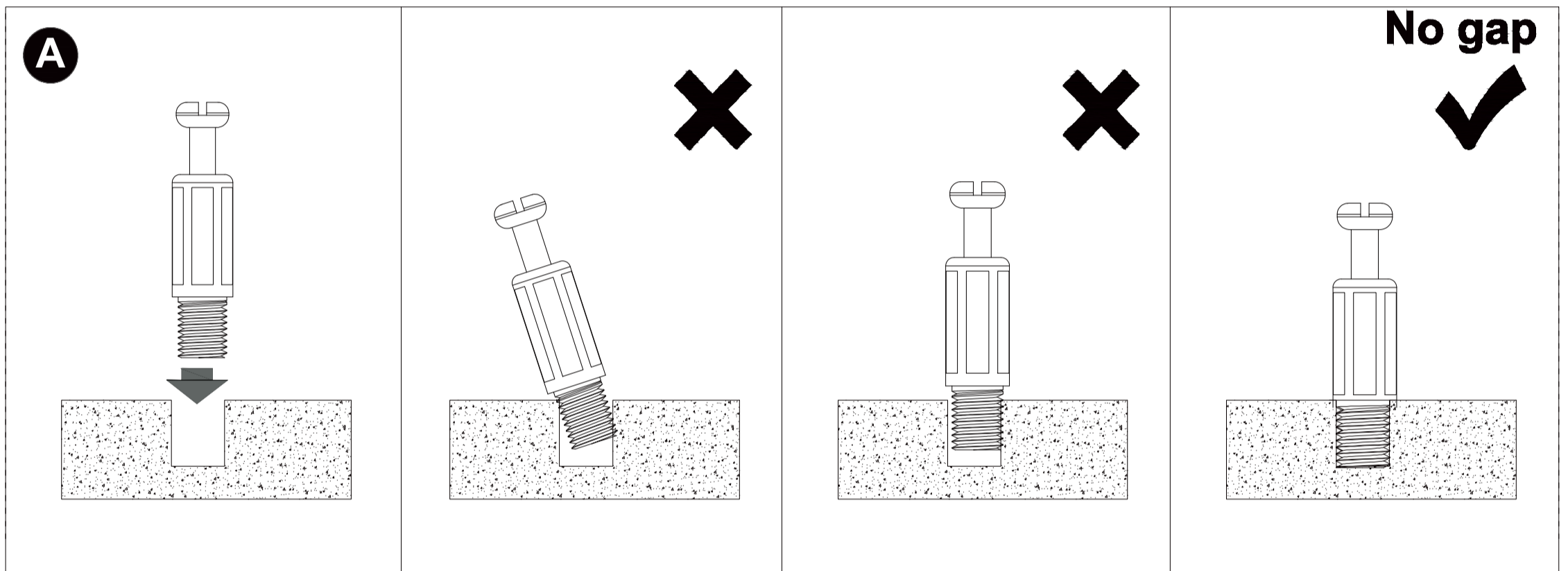
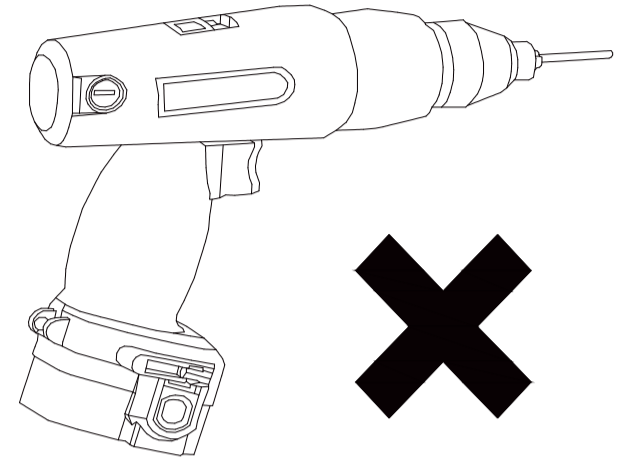

Screw the pin into the hole. Set the cams correctly by aligning the head of the cams with the lock pins. Lock the cam by turning the cam head with a screwdriver until it is tightened. Please do not use an electric screwdriver to assemble the unit.

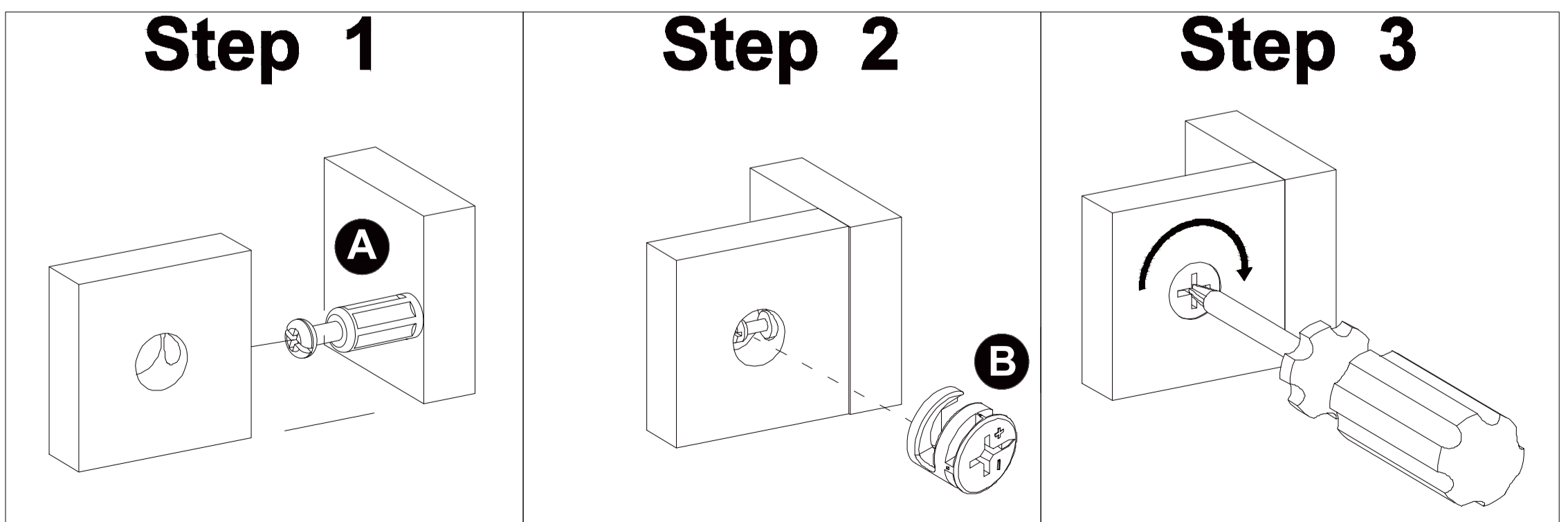

1

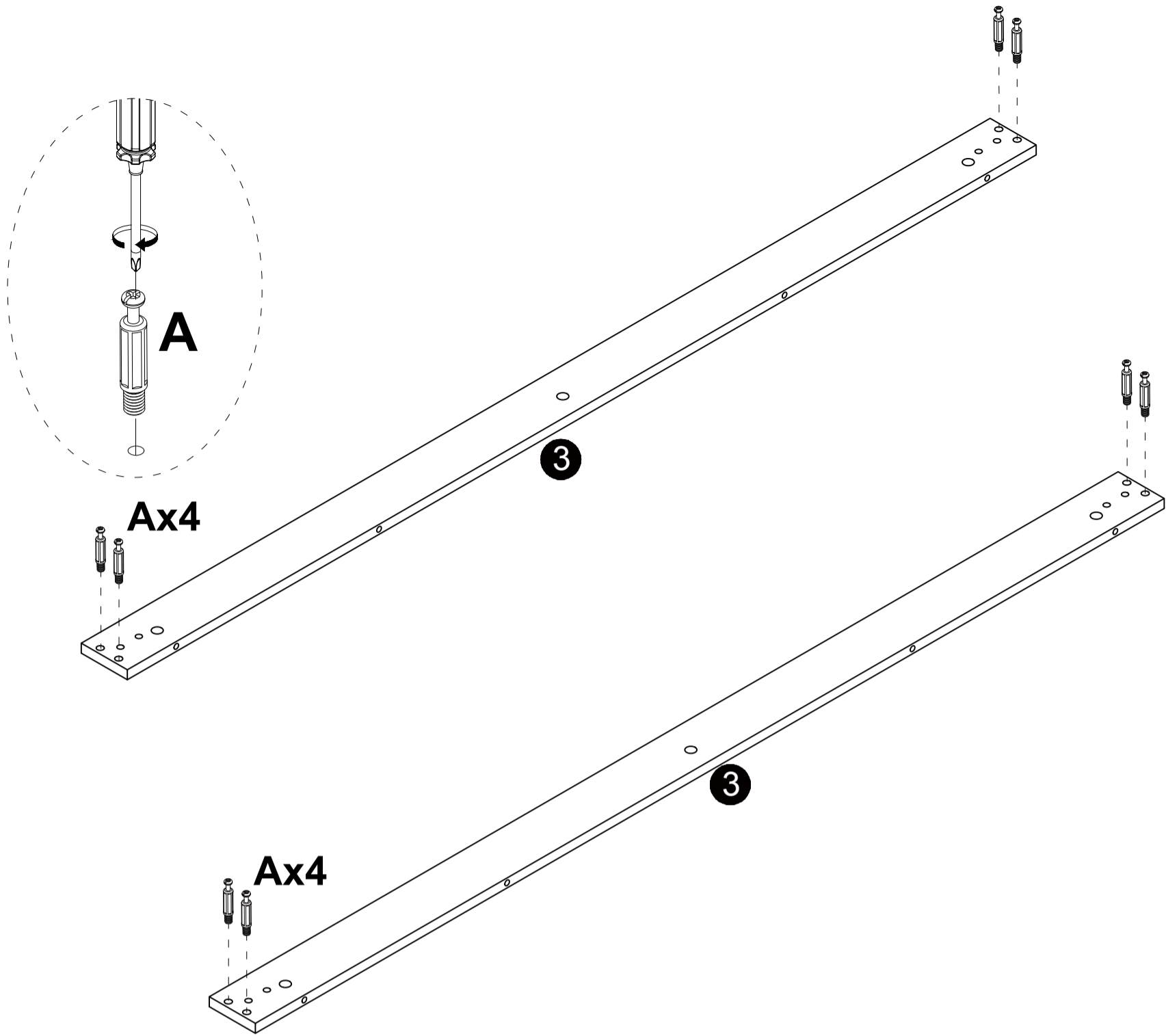

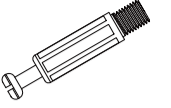
A

M6x40mm
8 pcs

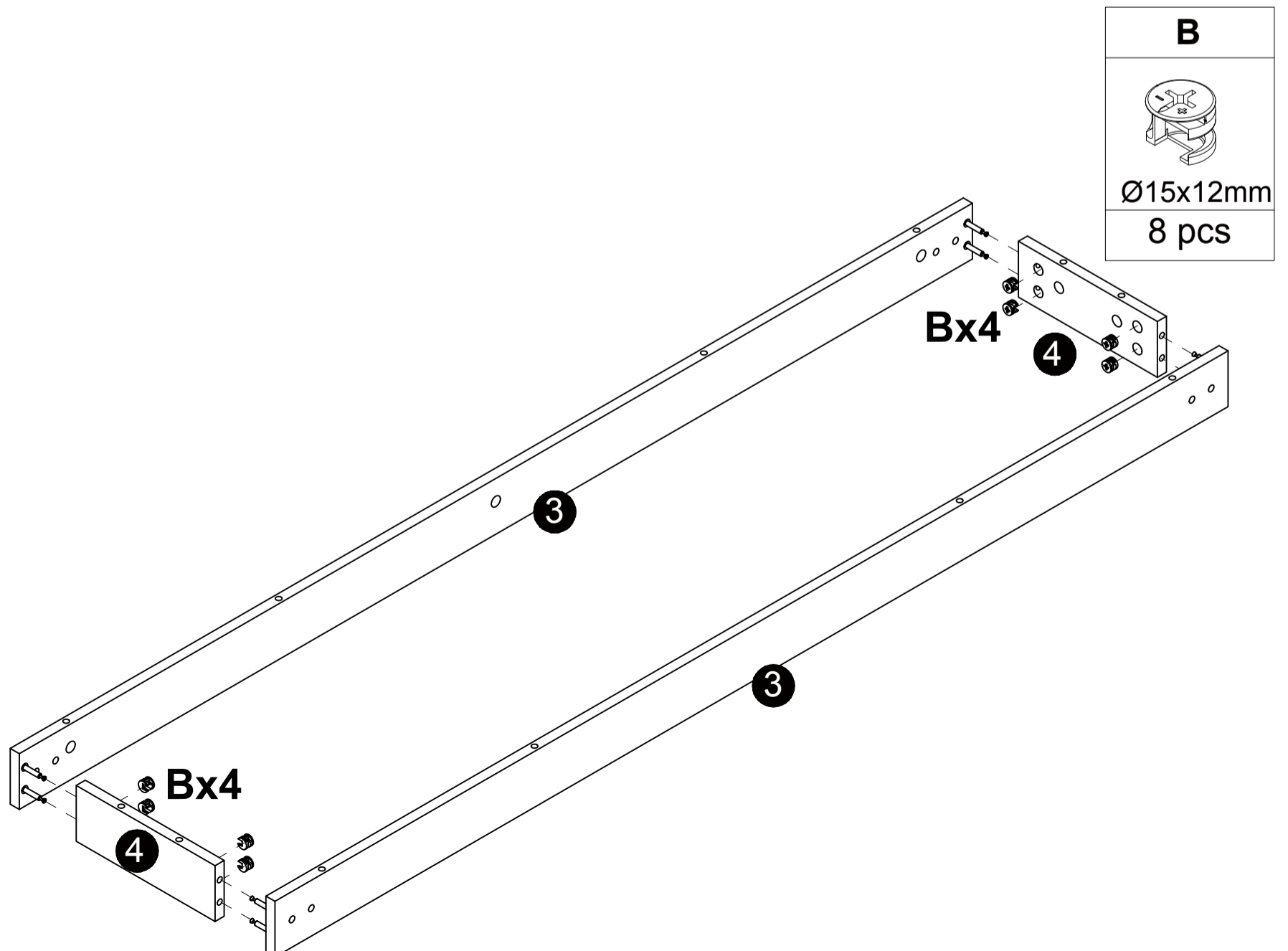
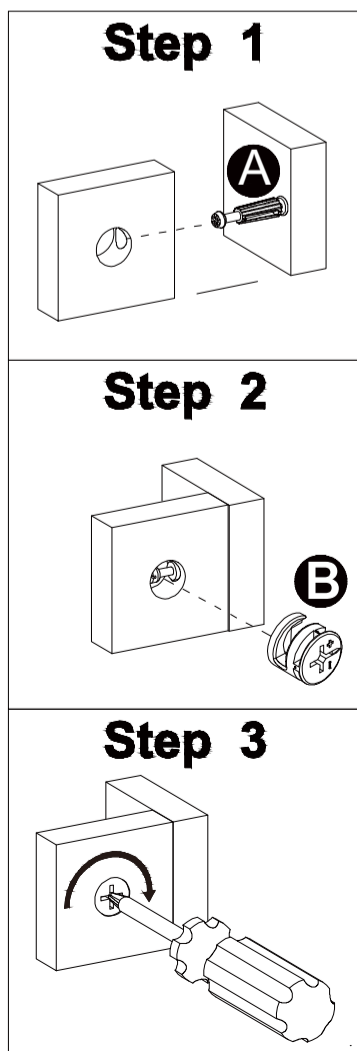
2

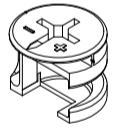

B

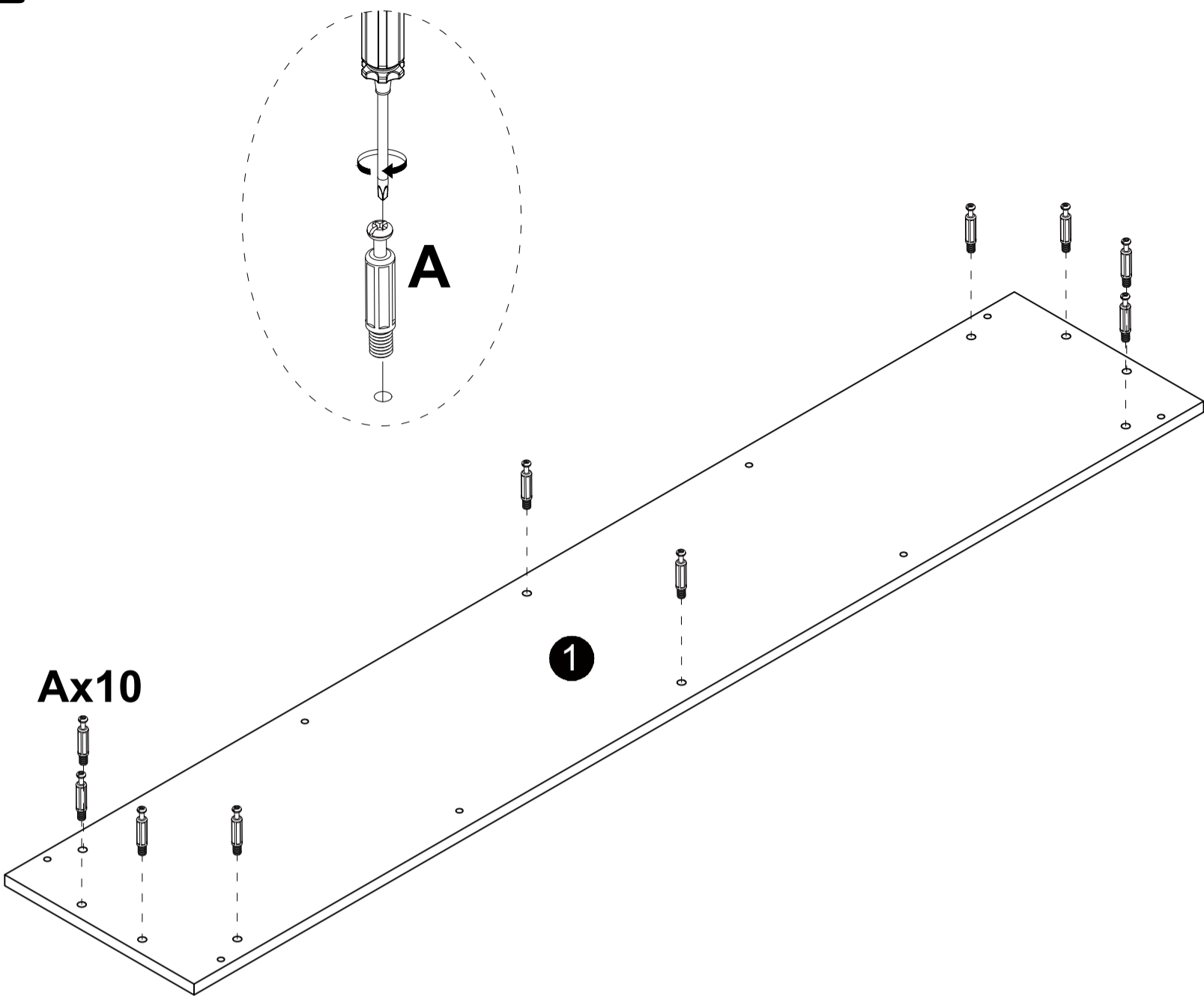
Ø15x12mm
8 pcs

3

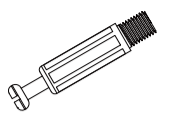

A

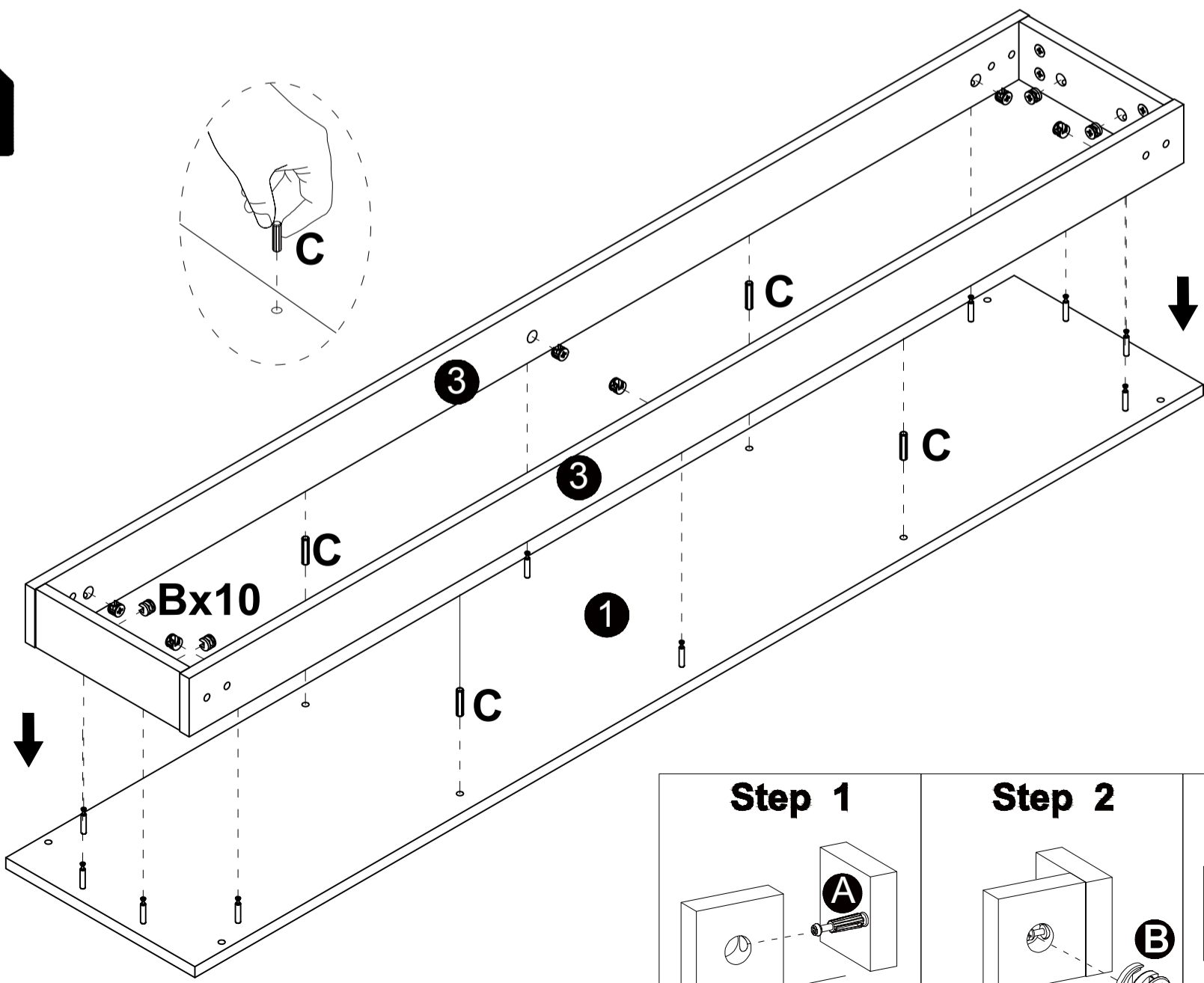
M6x40mm 10 pcs

4

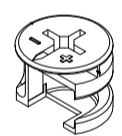

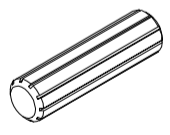
B

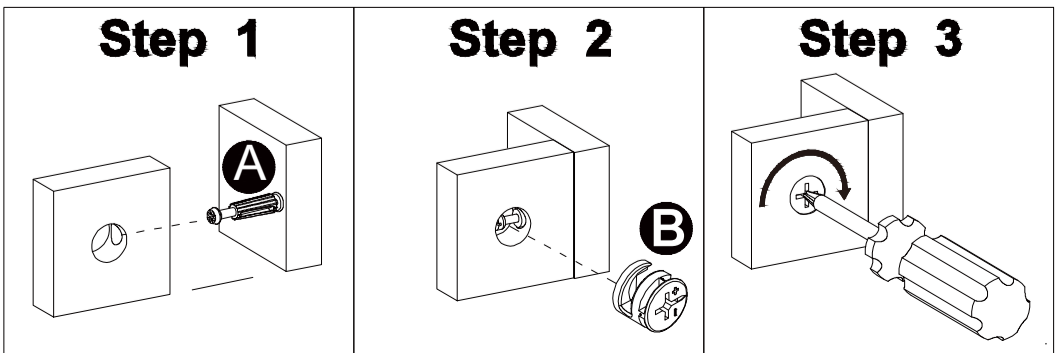
Ø15x12mm 10 pcs

C

Ø8x35mm 4 pcs

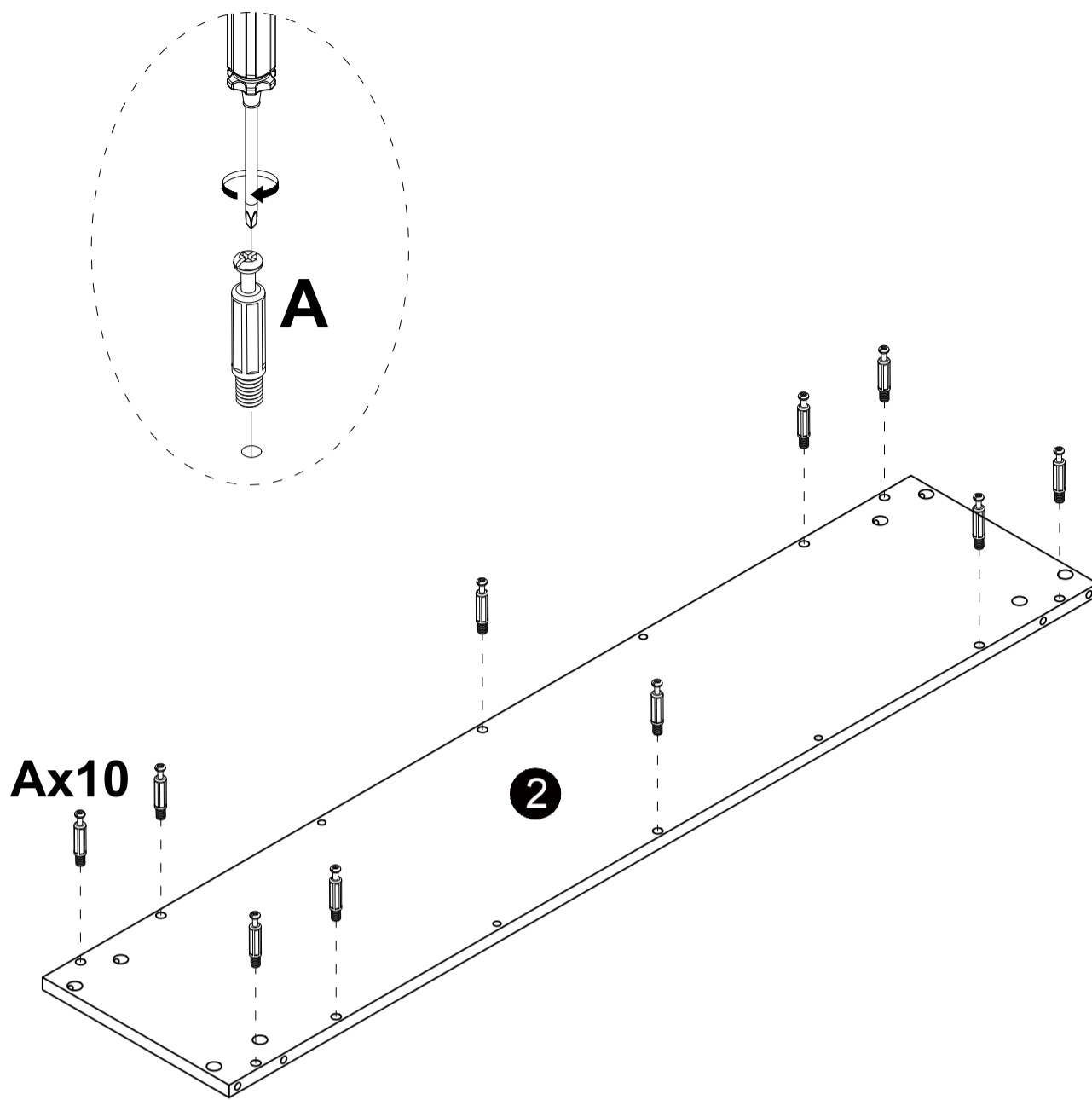

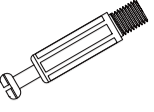

5

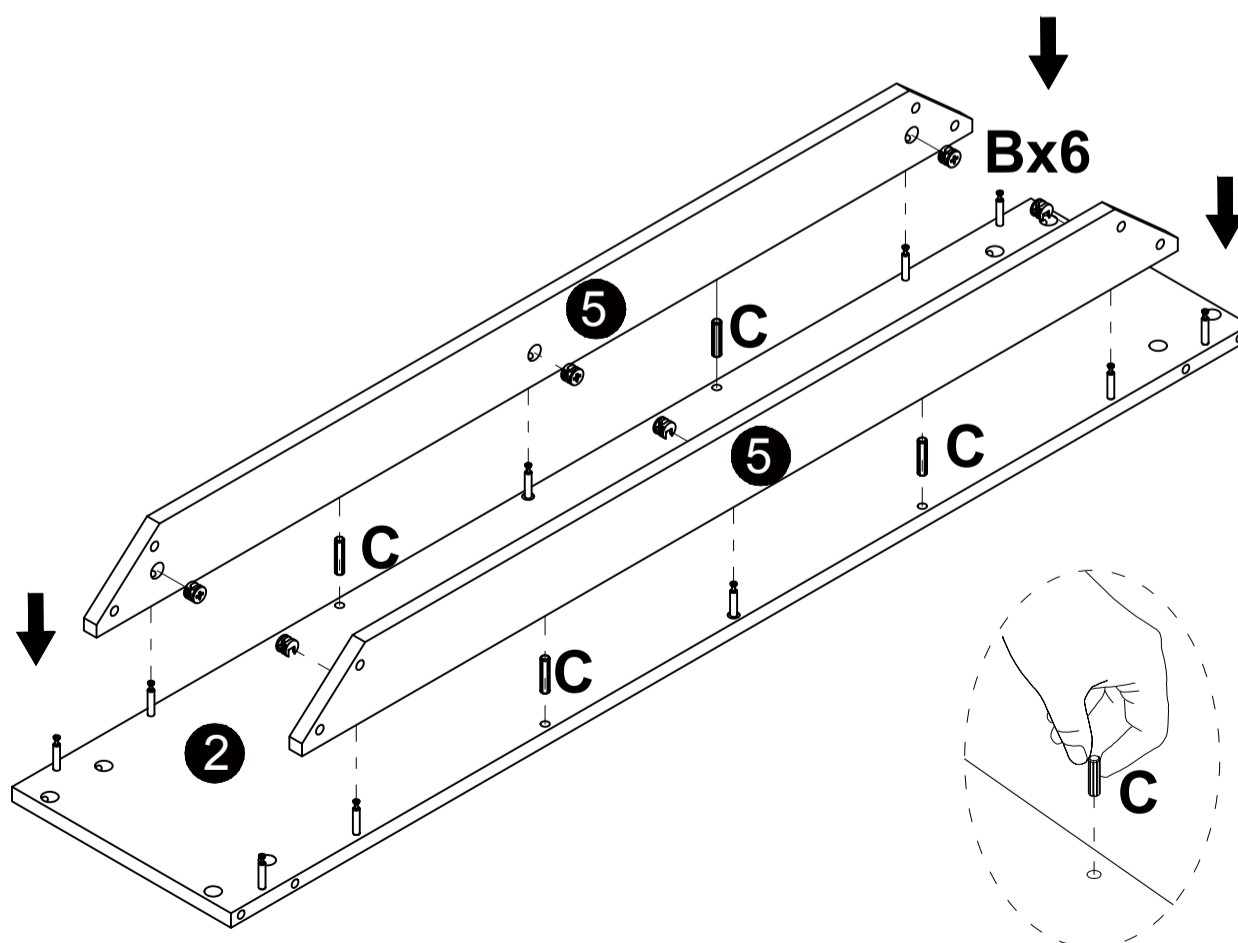
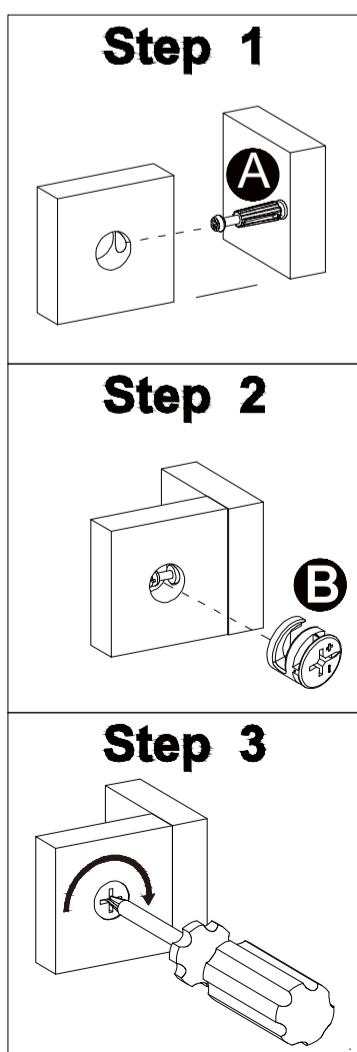

A

M6x40mm 10 pcs

6

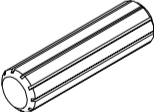

B

Ø15x12mm 6 pcs

C

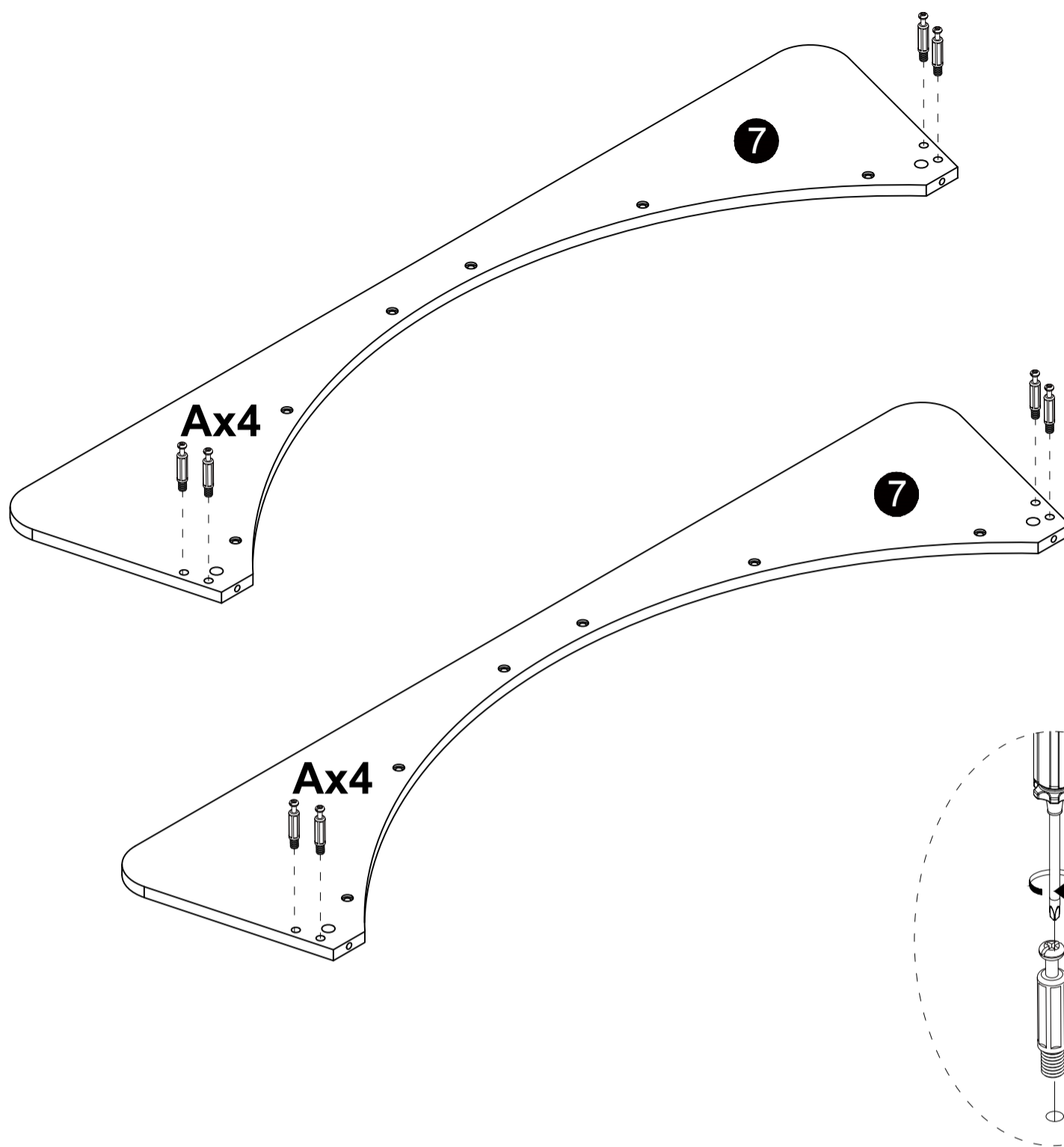
Ø8x35mm 4 pcs

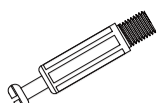
7

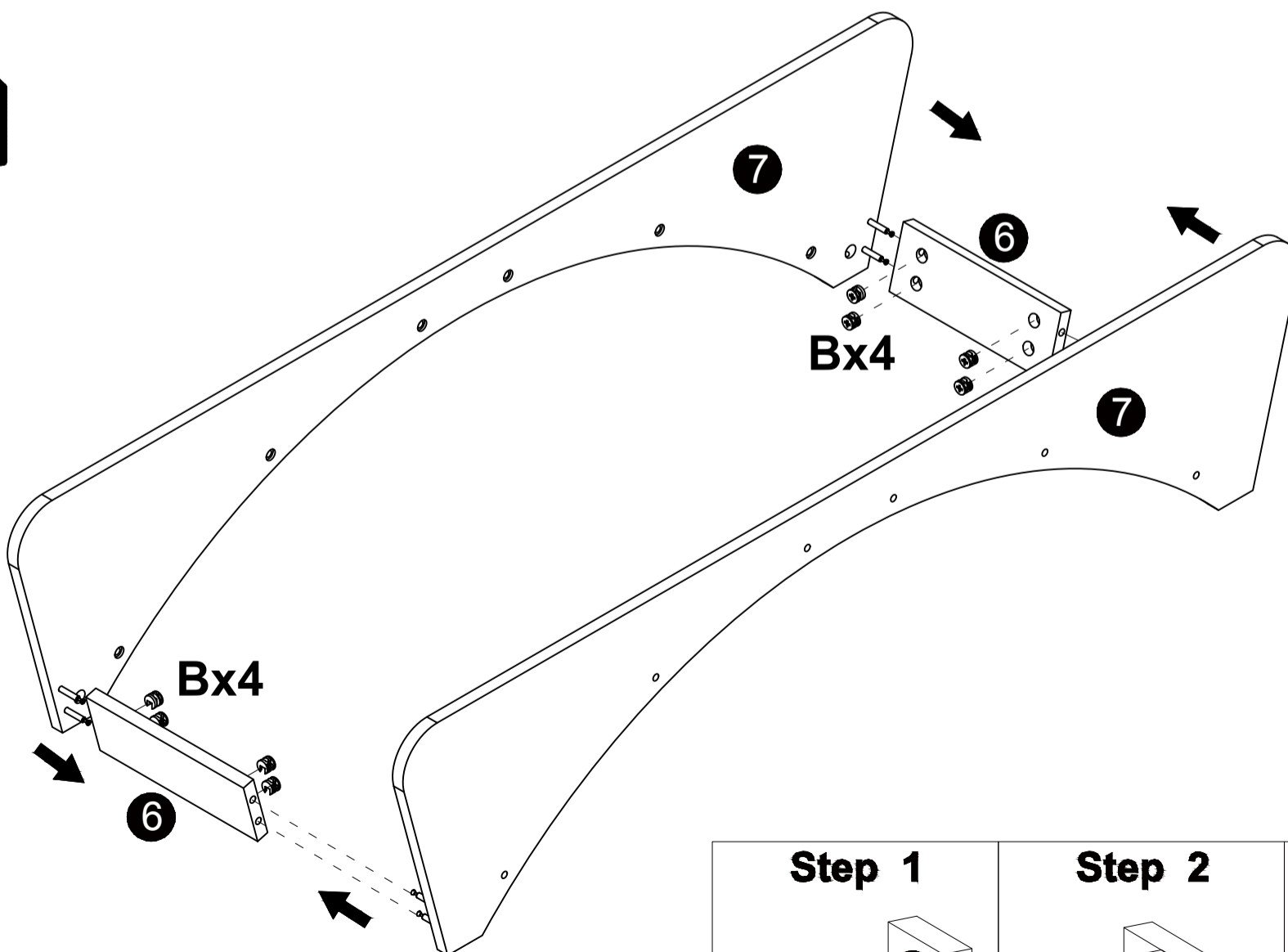

A

M6x40mm
8 pcs

8

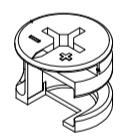

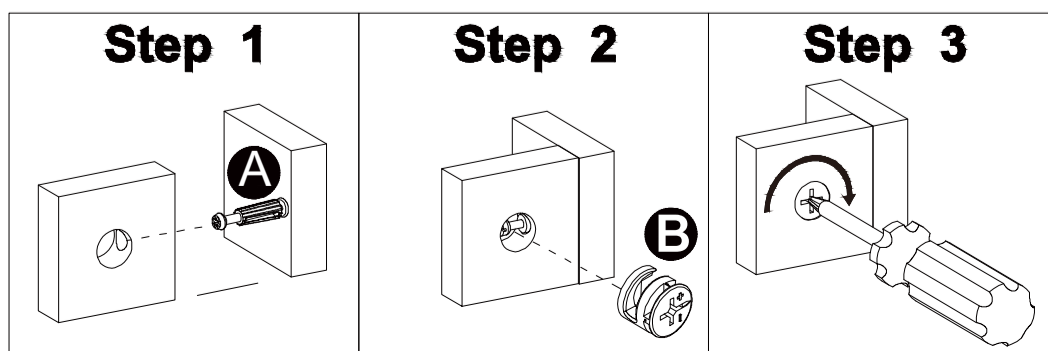
B

Ø15x12mm
8 pcs

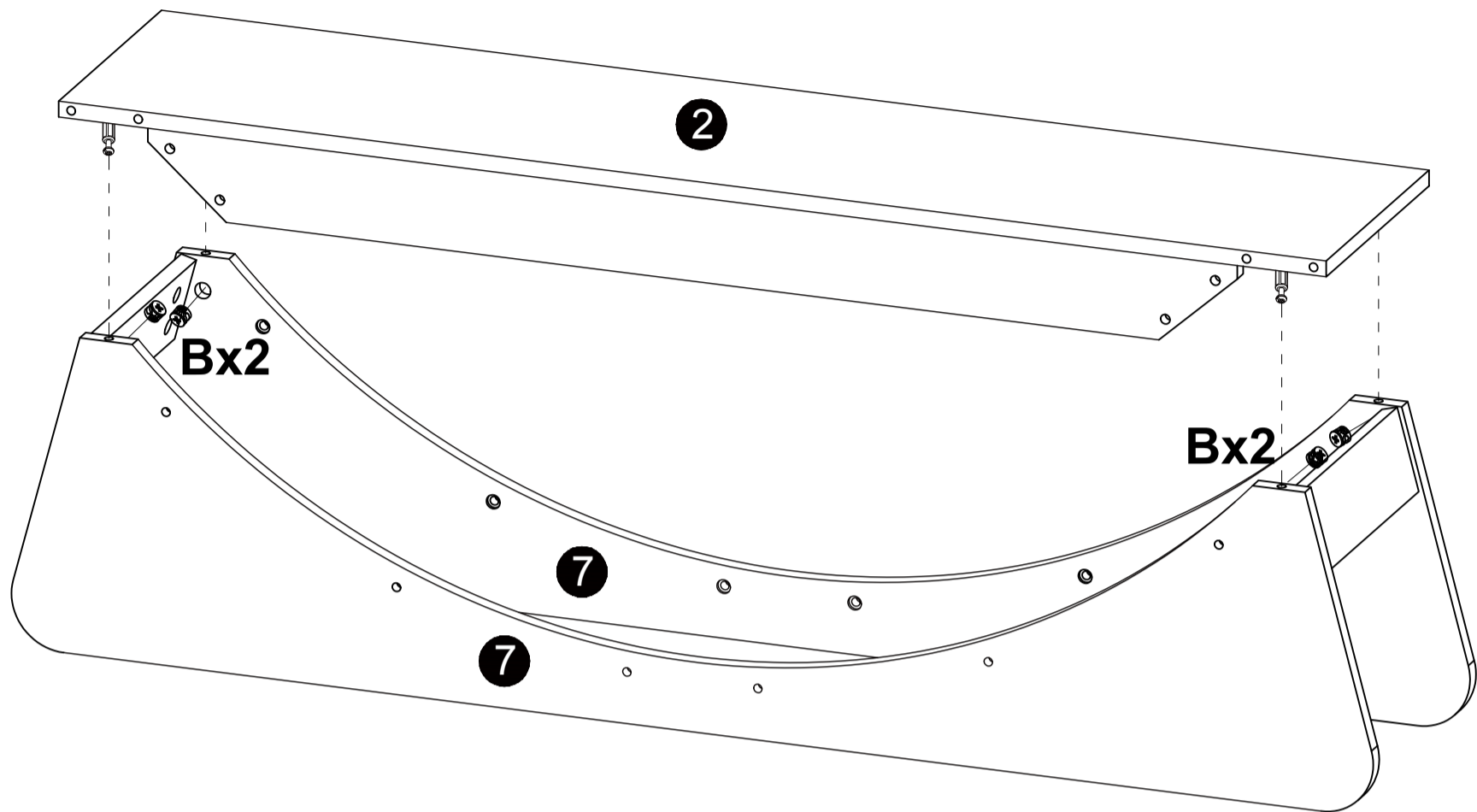

9

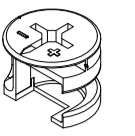

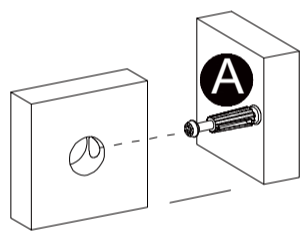
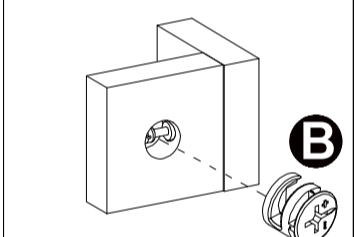
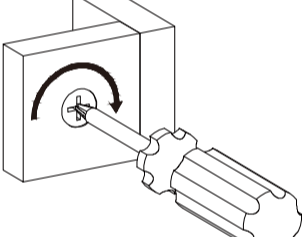
B

Ø15x12mm
4 pcs

Step 1	Step 2	Step 3
		

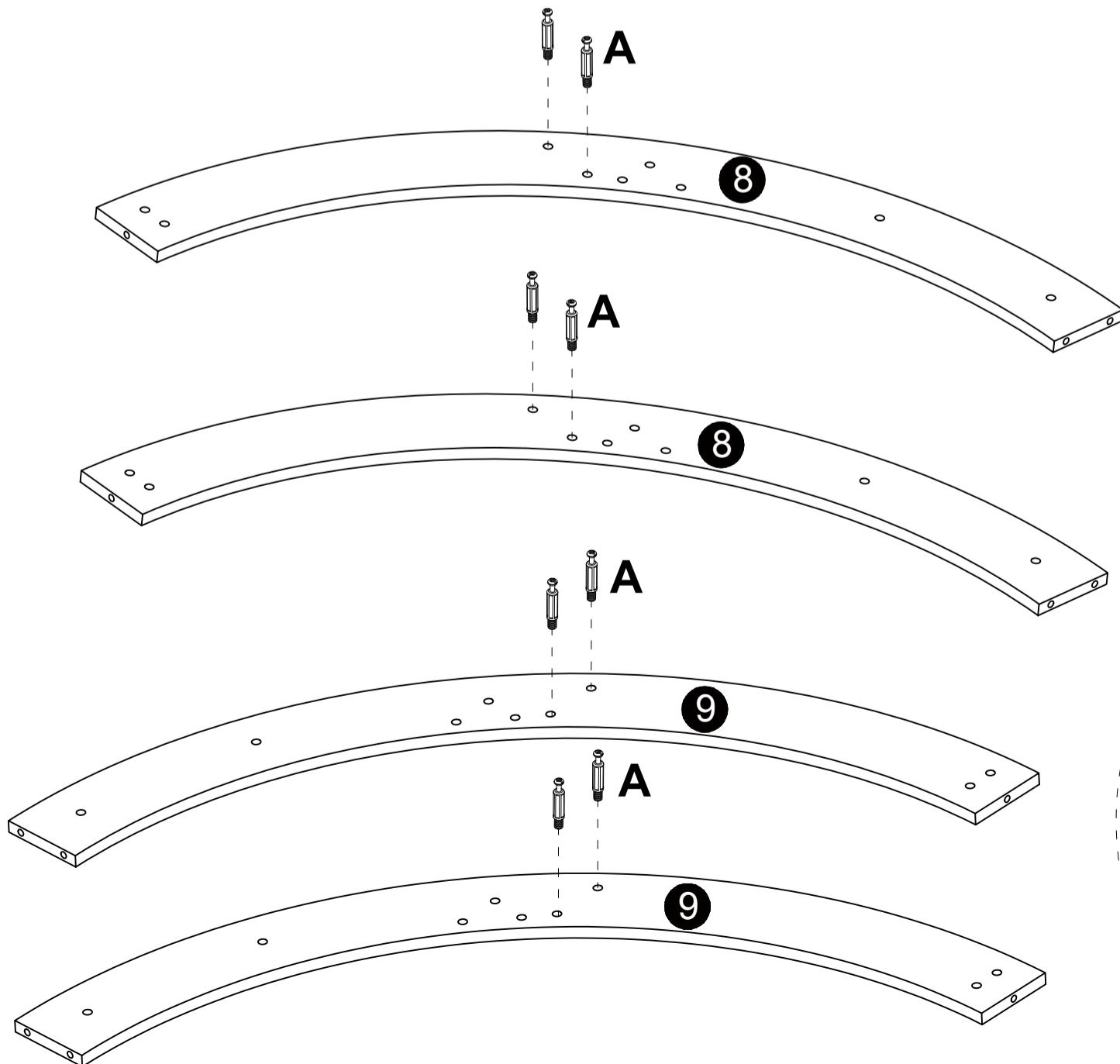
10

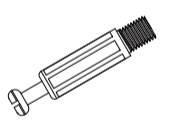

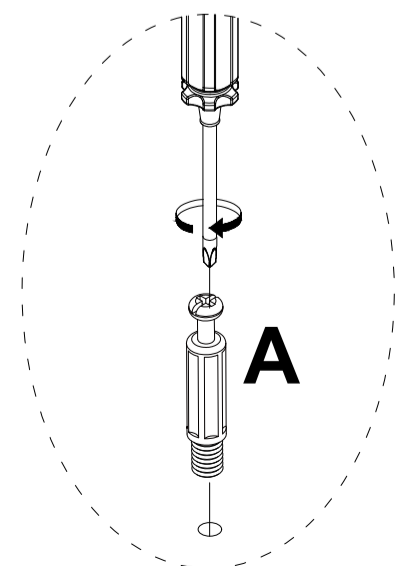
A

M6x40mm
8 pcs

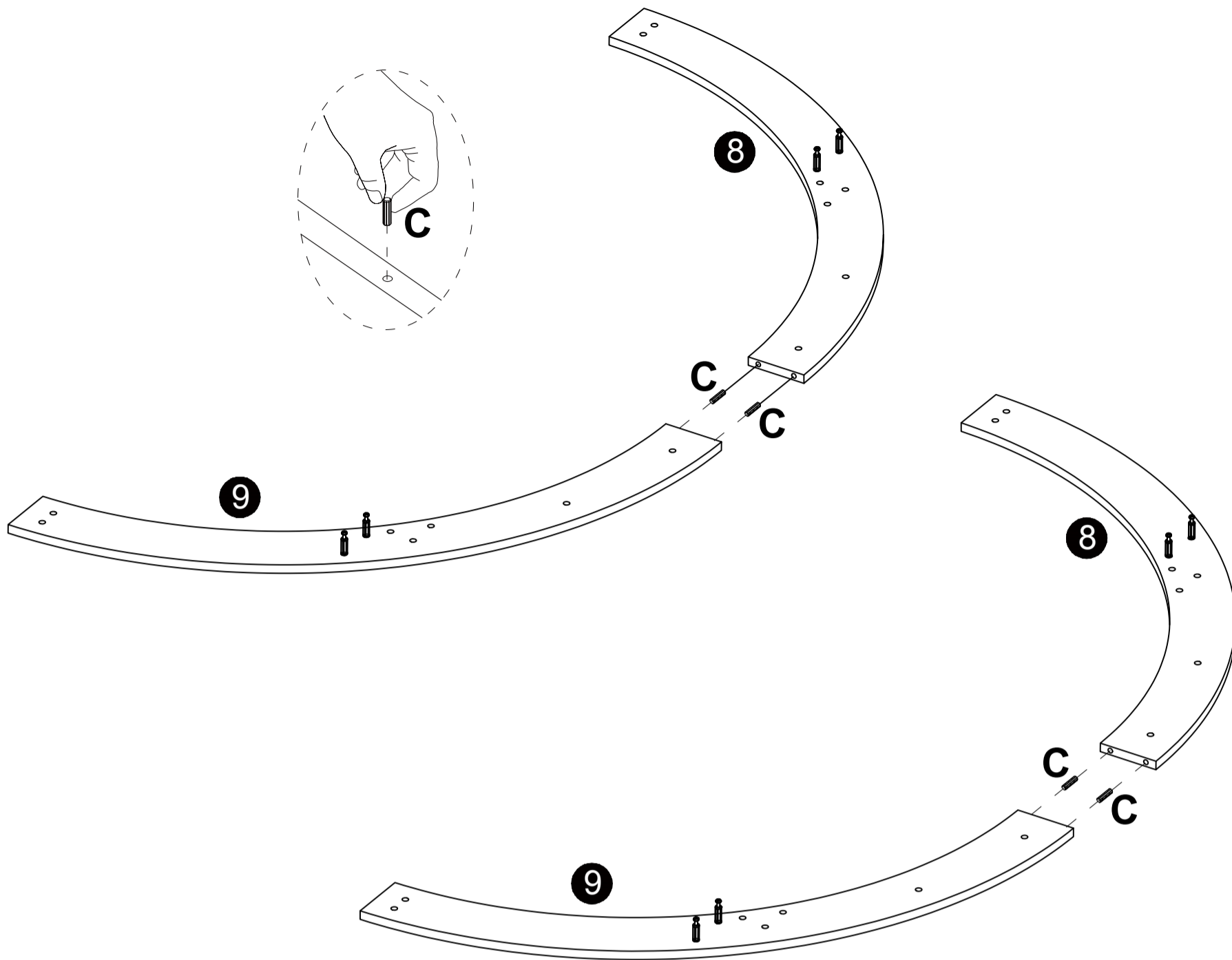

11

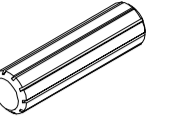

C

Ø8x35mm
4 pcs

12

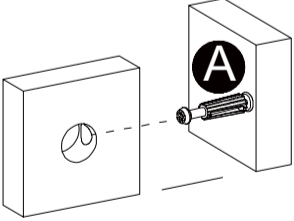
Step 1

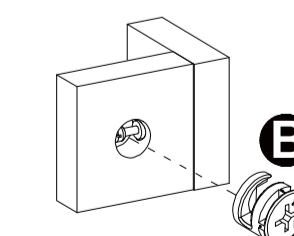

Step 2

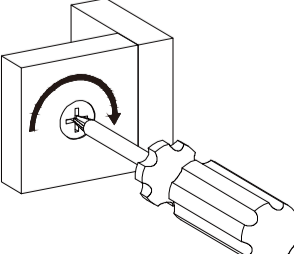
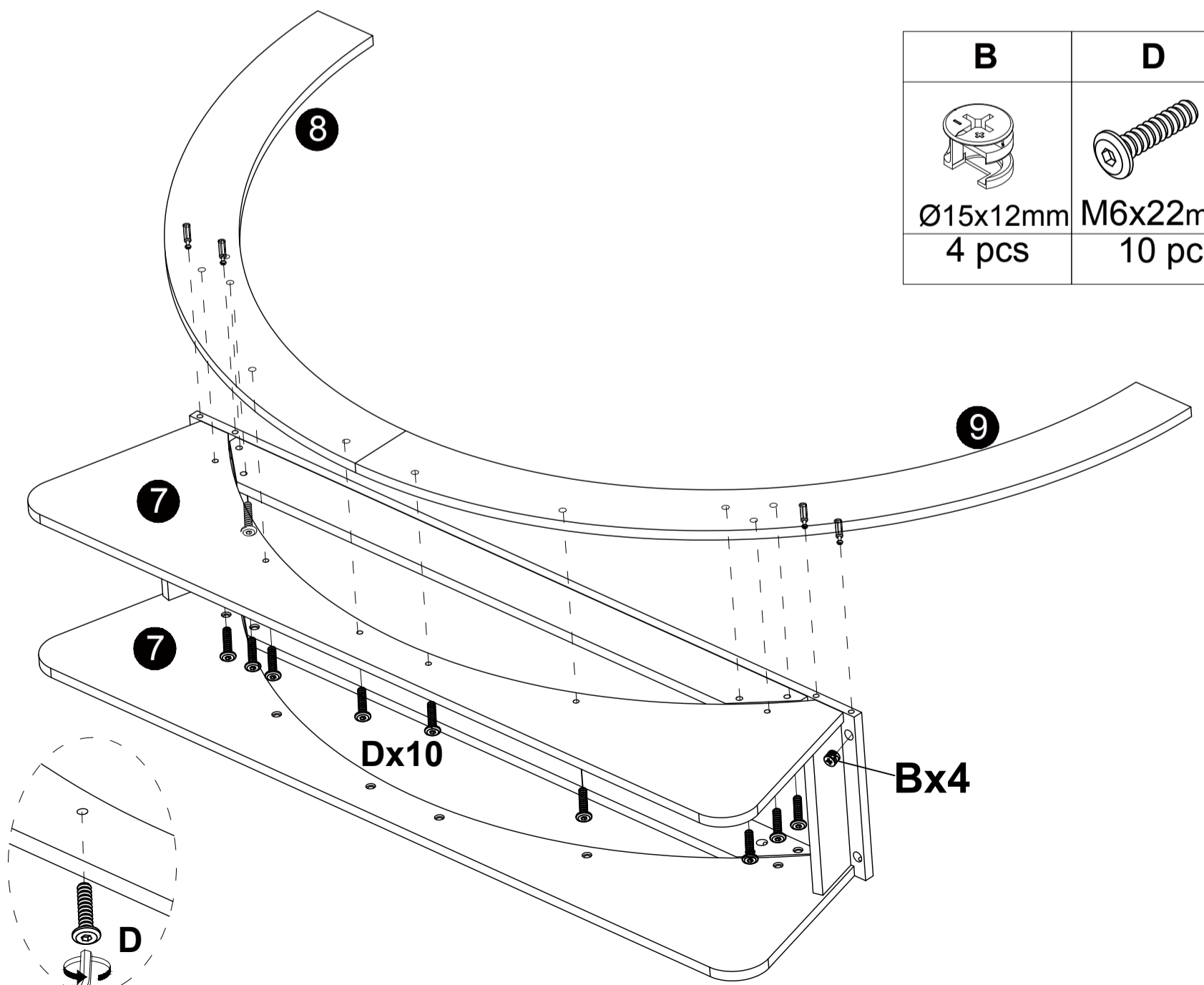

Step 3

B	D
	
Ø15x12mm	M6x22mm
4 pcs	10 pcs

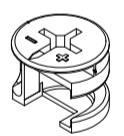
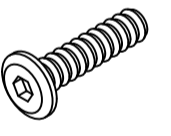
13

Step 1

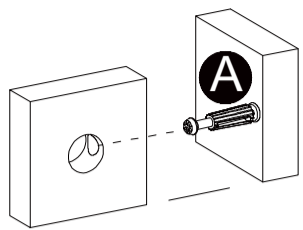

Step 2

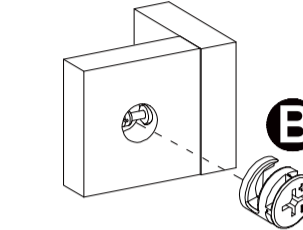

Step 3

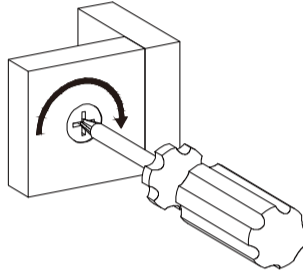
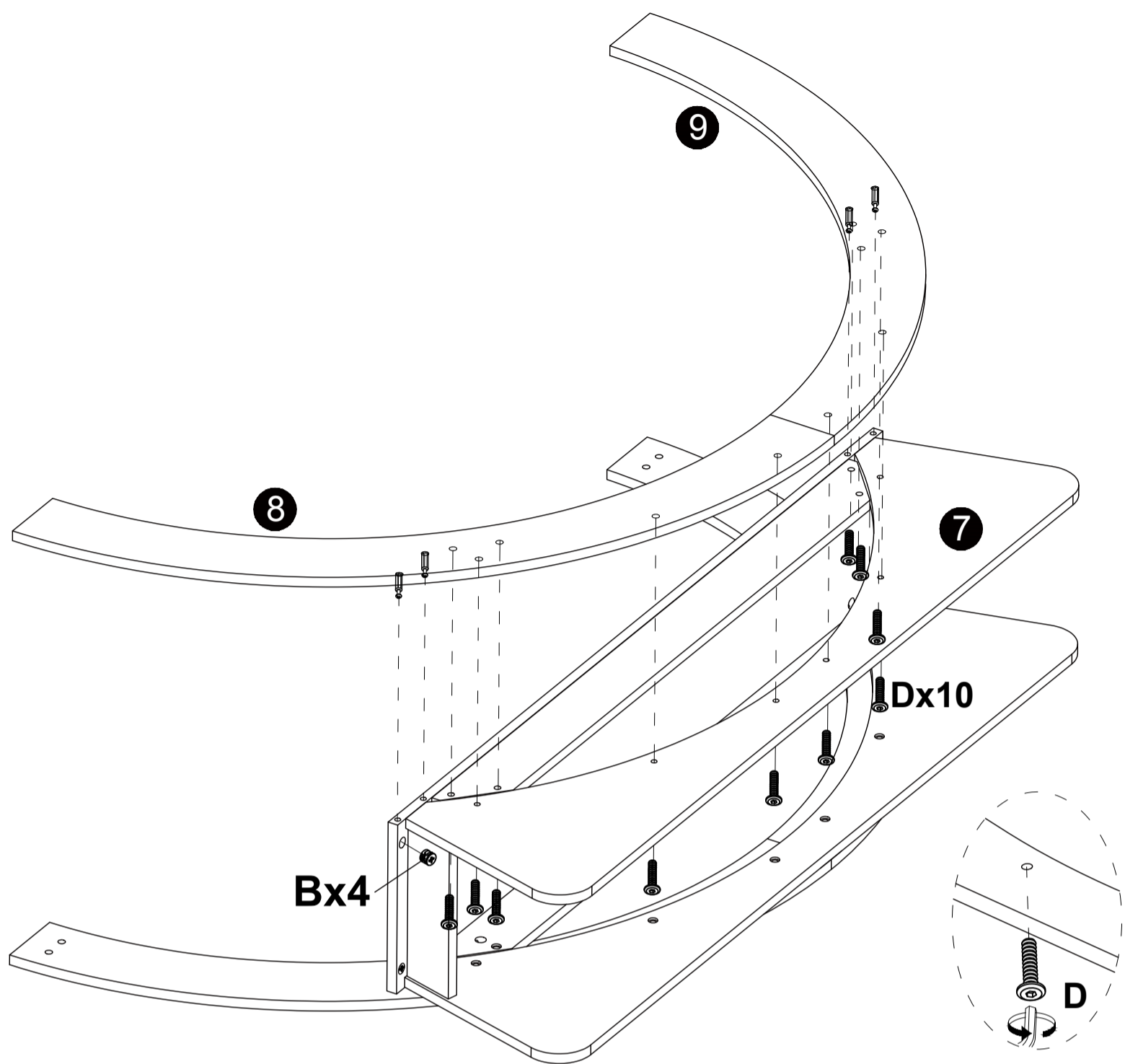
B

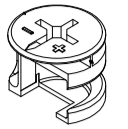

Ø15x12mm
4 pcs

D



M6x22mm
10 pcs

14

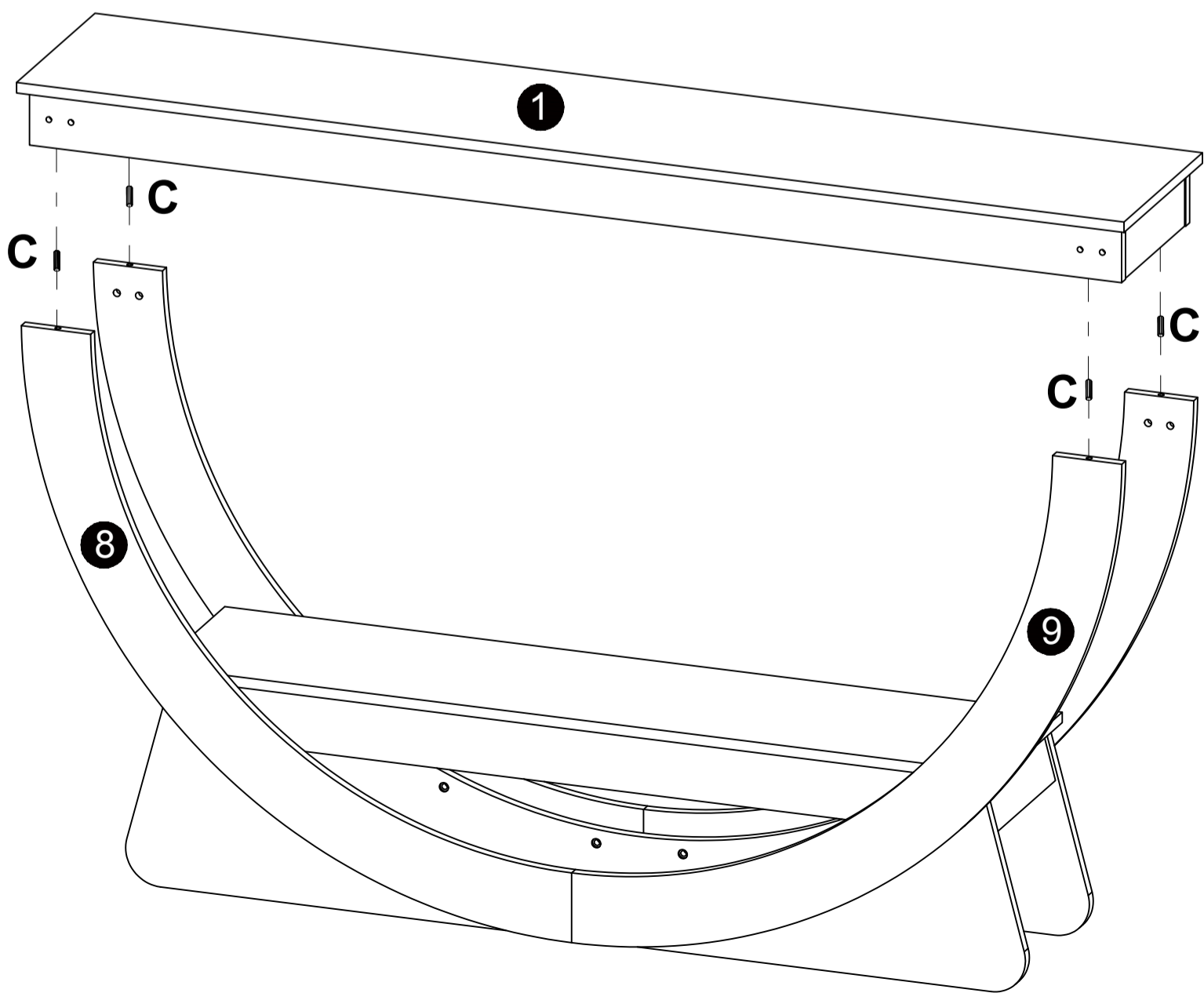

C

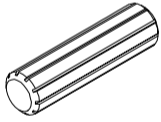

Ø8x35mm
4 pcs

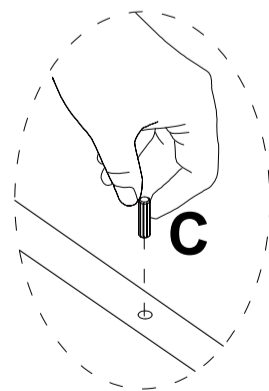

15

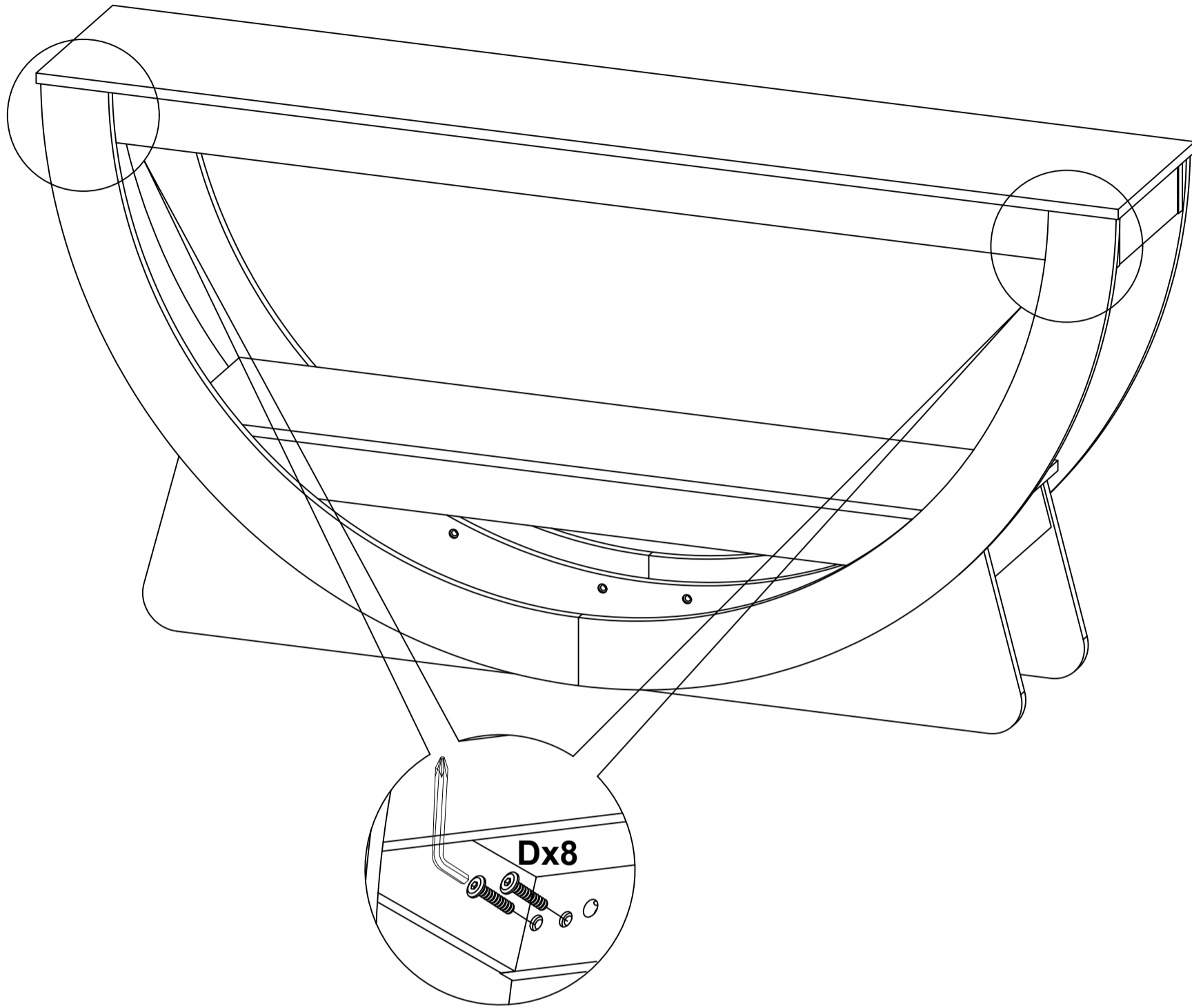

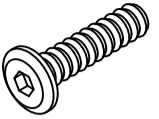

D

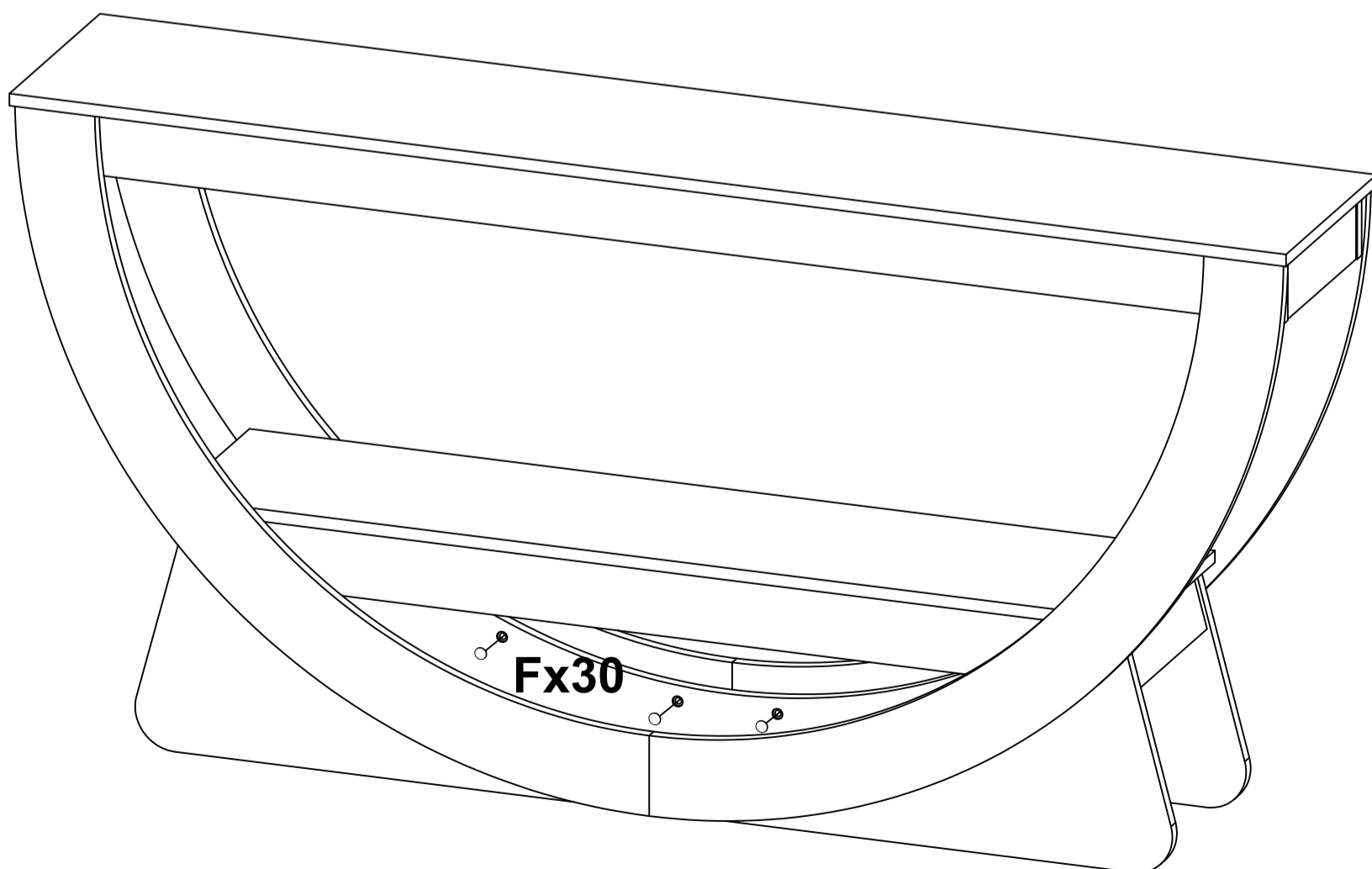
M6x22mm
8 pcs

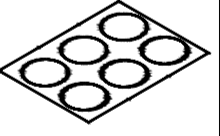
16

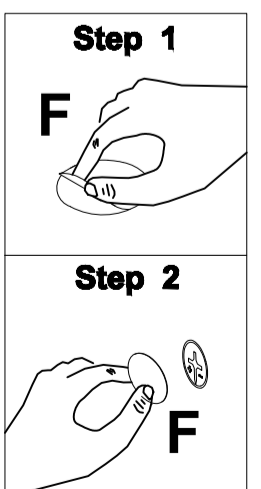

F

Ø20
30 pcs

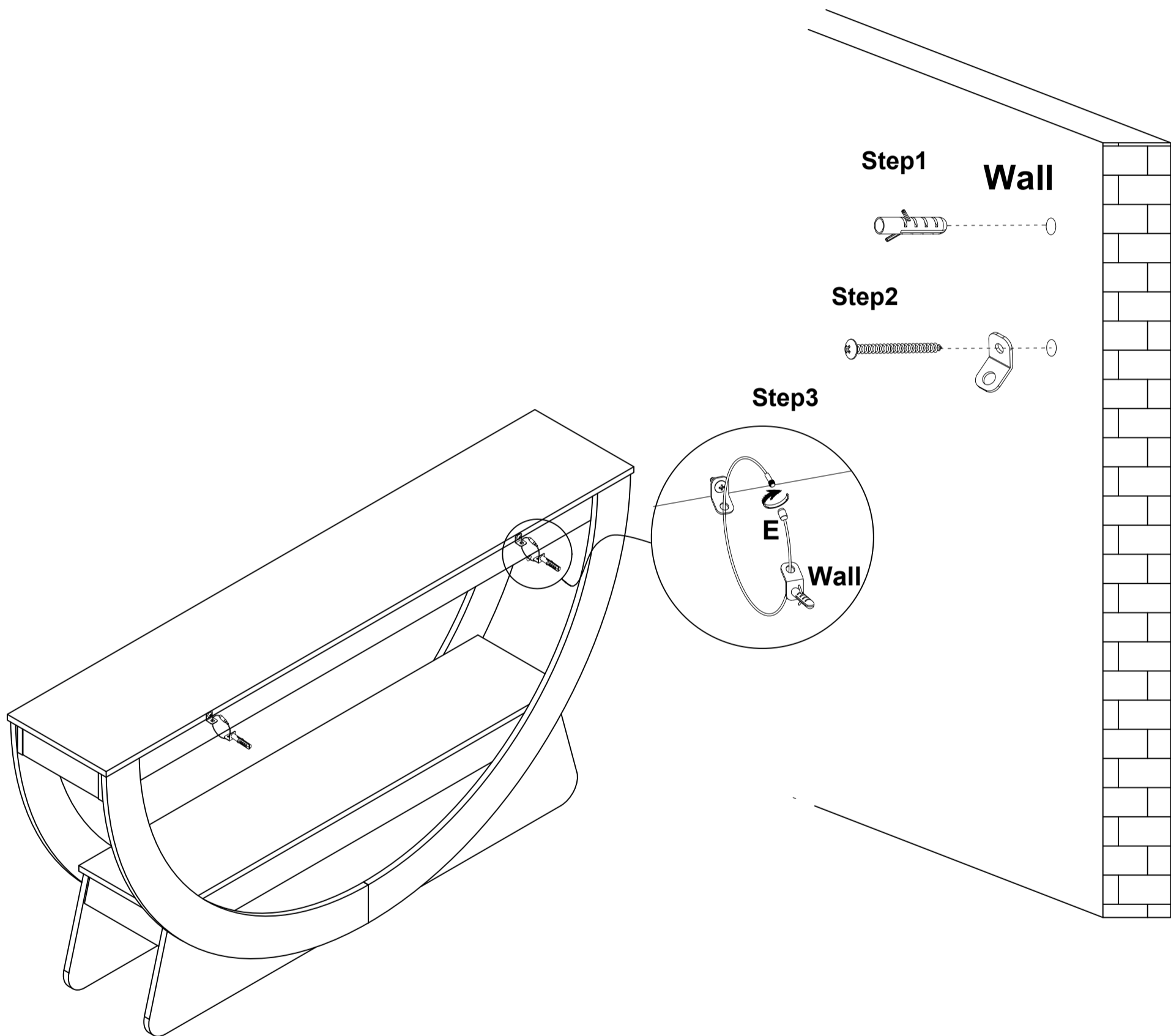

E

2 pcs



Thank you for your support!

