

# ASSEMBLY INSTRUCTIONS

029-925 Sofa Table

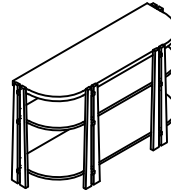

## TOOLS REQUIRED:

Phillips Head Screwdriver (Not Provided)





## BEFORE YOU START:

1. Check the parts against the parts list to make sure all items are present.
2. Assemble your furniture on a soft, flat surface to avoid scratching the finish.
3. **CAUTION:** Do not over tighten screws, nuts or bolts during assembly.
4. Your furniture may require occasional tightening.

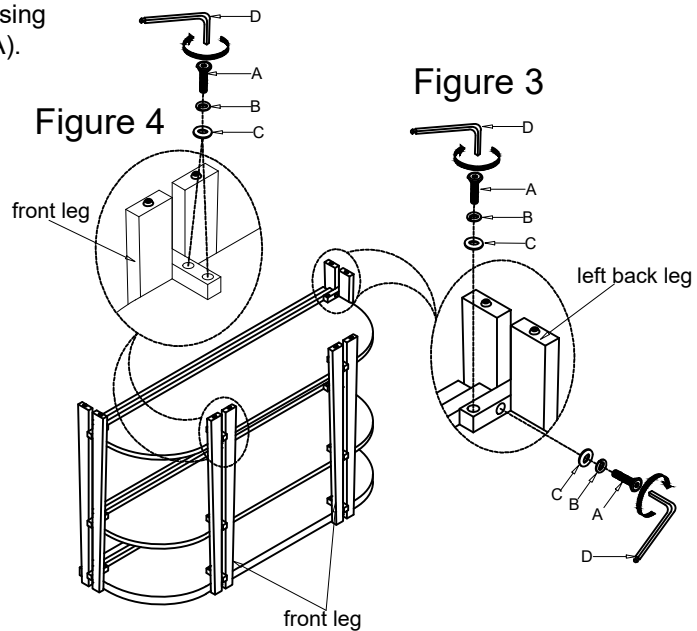
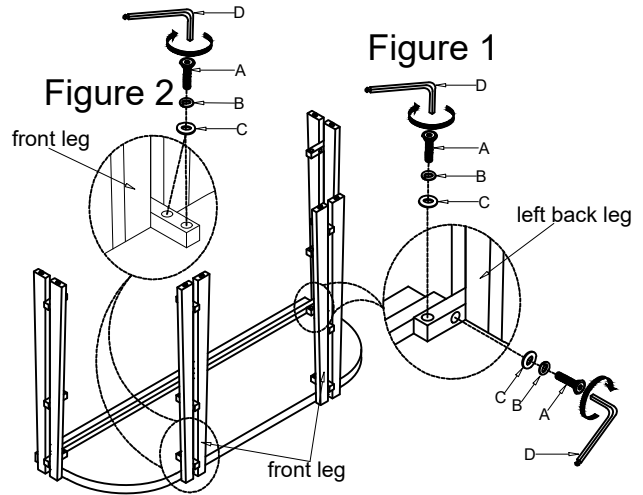
## INSTRUCTIONS:

1. Turn the table top upside down on to a clean soft surface.
2. Attach front legs and back legs to the table, using Bolt (A), Lock washer (B) and Flat washer (C). With Allen key (D). (See Figure 1 & 2).
3. Install upper shelf and lower shelf into slot of legs, align pre-drilled holes in shelf with metal bracket holes that are attached to the legs, using Flat Washer (B), Lock Washer (C) and Bolt (A). (See Figure 3 & 4).  
Tighten all Bolts with Allen key (D).



No.	Hardware List	Q'ty
A	 Bolt Ø1/4" x L1-1/4"	24
B	 Lock Washer Ø1/4"	24
C	 Flat Washer Ø1/4"	24
D	 Allen key 4mm	1