

# Assembly Instructions

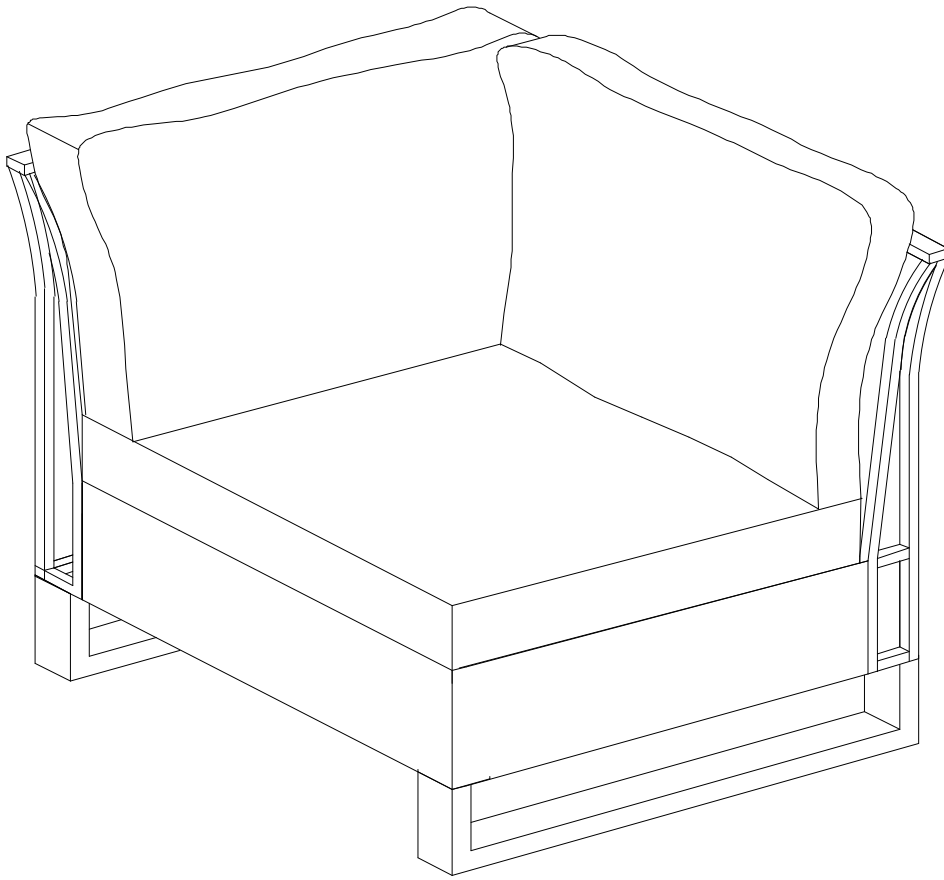



For any missing hardware, damaged parts and other problems.  
WELCOME to email us

**\*Don't fully tighten all the bolts till the very end!**

## PRE-ASSEMBLY PREPARATION:

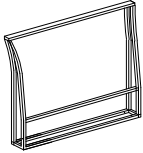
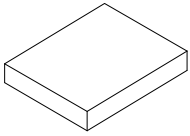
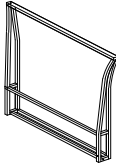
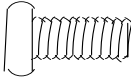
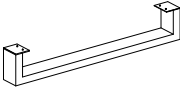
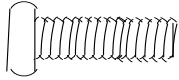
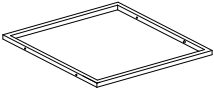
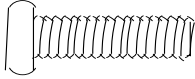
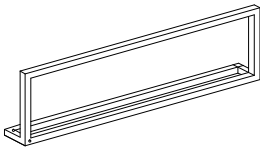
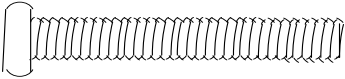
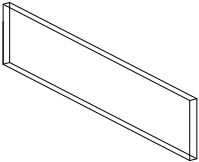
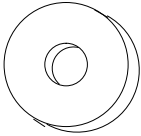
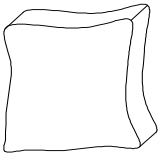
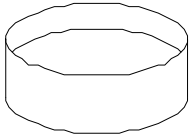
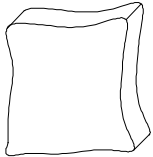
- Please read through the instructions before beginning assembly.
- Clear out the space for assembly and lay out all of the parts based on the Parts List, extra room will allow you to easily determine if all the pieces are present.
- Keep small parts and pieces away from children until fully assembled.

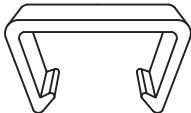
Part no.	Part	QTY	Image	Part no.	Part	QTY	Image
A	Long back panel	1		I	Seat cushion	1	
B	Short back panel	1		J	Bolt (M6*20mm)	8	
C	U-foot	2		K	Bolt (M6*35mm)	7	
D	Seat panel	1		L	Bolt (M6*40mm)	4	
E	Side panel	1		M	Bolt (M6*80mm)	1	
F	Side panel	1		N	Washer M6	20	
G	Long back cushion	1		O	Bolt cap M6*13mm	1	
H	Short back cushion	1		P	Allen wrench	1	
Q	Lock	4					

**Step 1:** Attach U-foot C to back panel A with 4pcs bolts J and 4pcs washers N, using Allen wrench P. Note: Don't fully tighten the bolts.

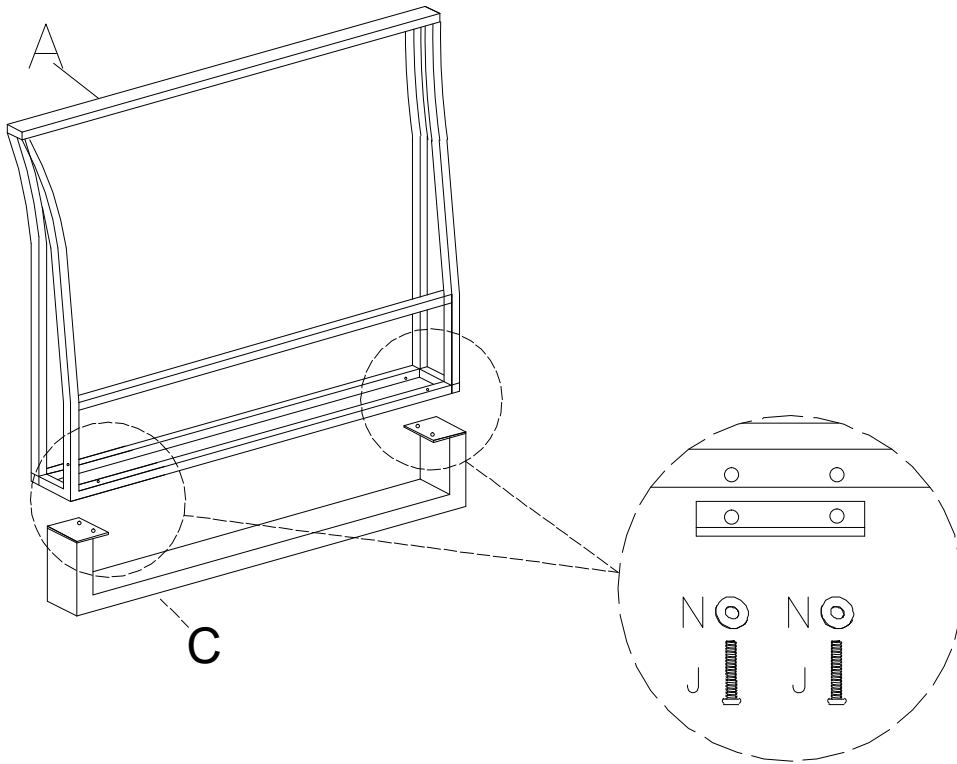

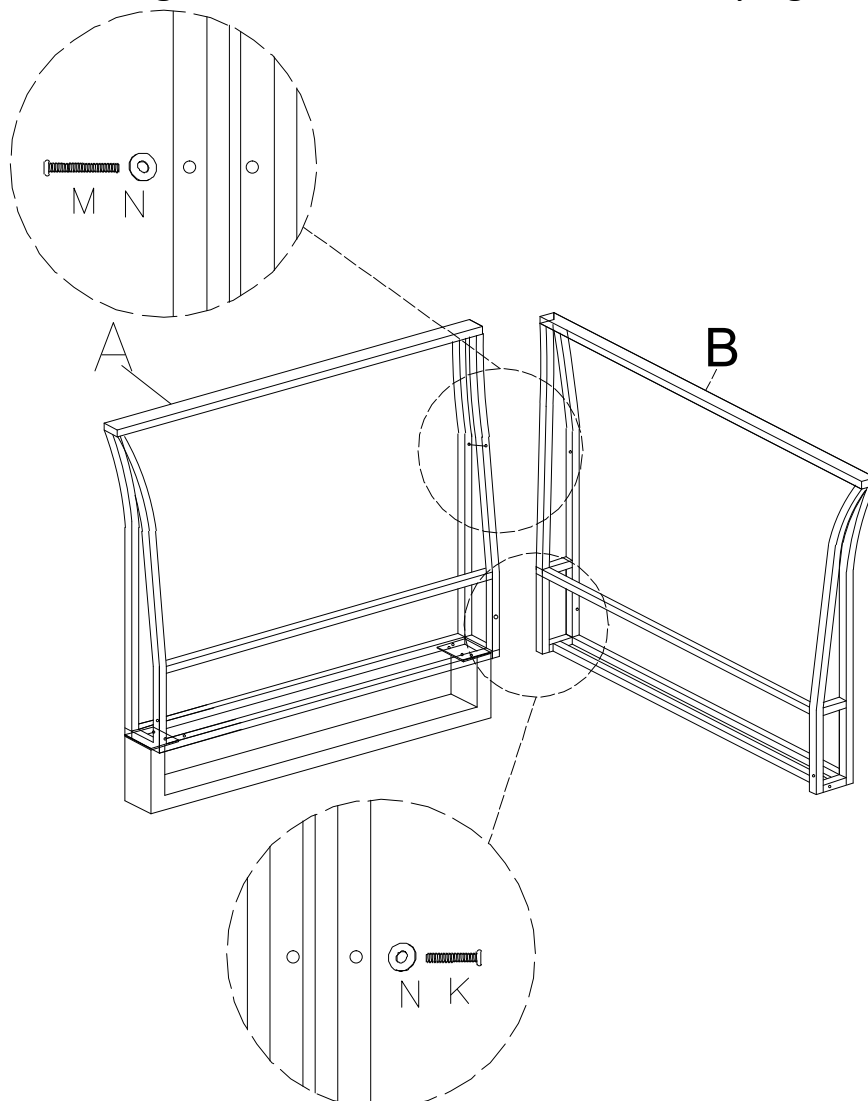

**Step 2:** Attach back panel A&B with 1pc bolt M, 1pc bolts K and 2pcs washers N, using Allen wrench P. Note: Don't fully tighten the bolts.

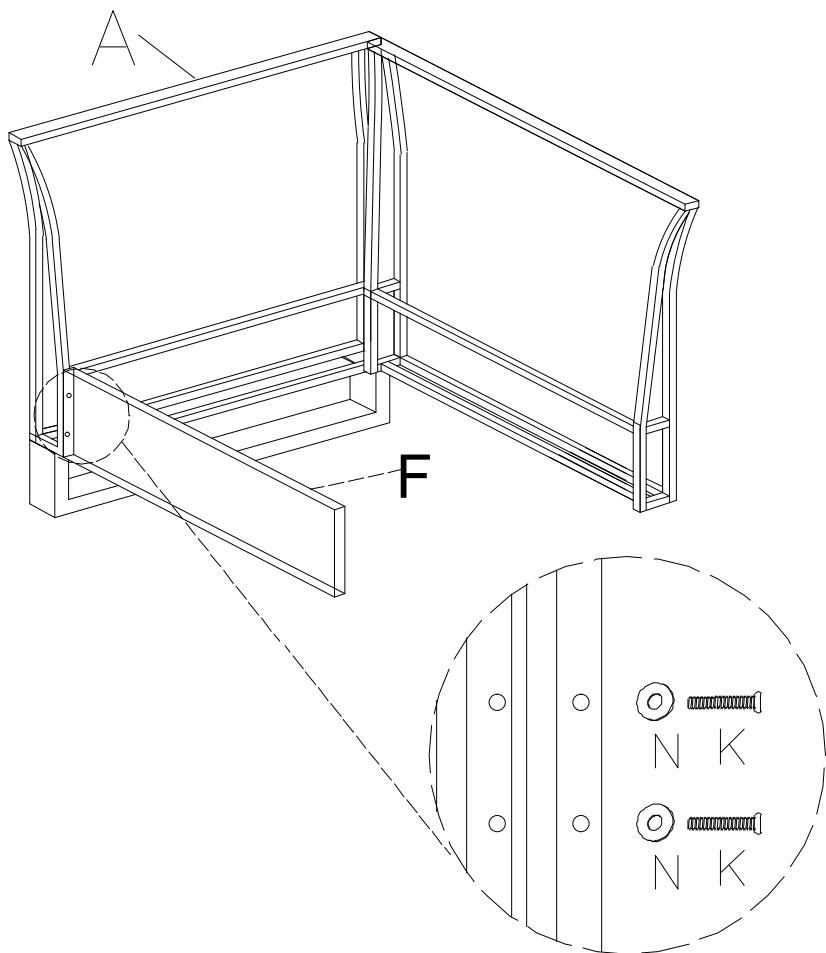

**Step 3:** Attach side panel F to part A with 2pcs bolts K and 2pcs washers N, using Allen wrench P. Note: Don't fully tighten the bolts.



K		M6*35	2
N		M6	2

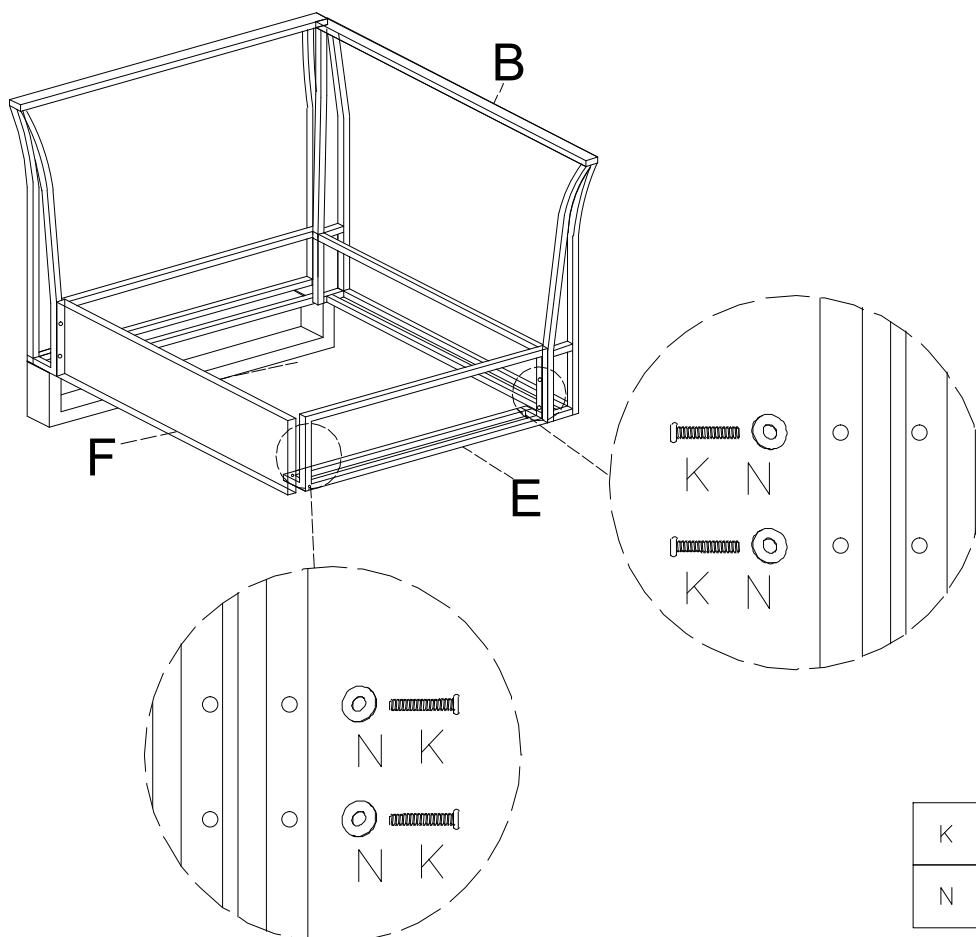

**Step 4:** Attach side panel E to part B and part F with 4pcs bolts K and 4pcs washers N, using Allen wrench P. Note: Don't fully tighten the bolts.



K		M6*35	4
N		M6	4

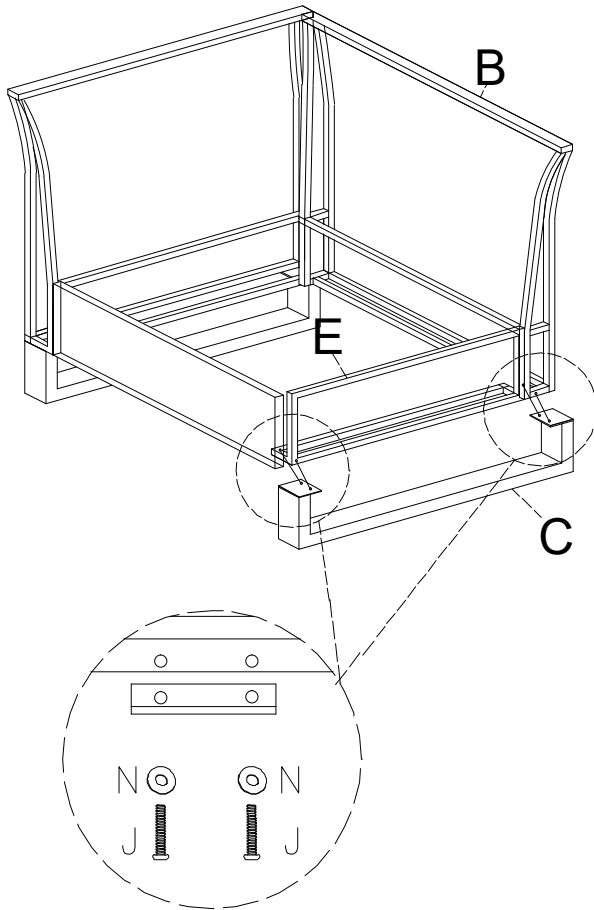

**Step 5:** Attach U-foot C to part E and part B with 4pcs bolts J and 4pcs washers N, using Allen wrench P. Note: Don't fully tighten the bolts.



J		M6*20	4
N		M6	4

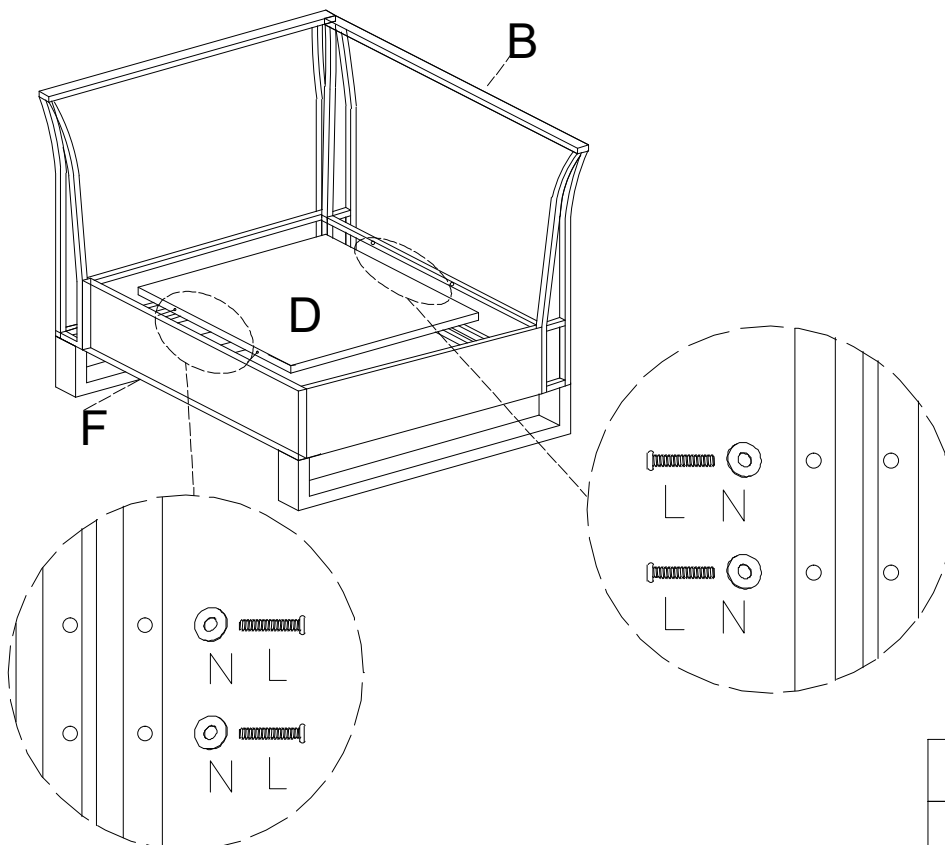

**Step 5:** Attach seat panel D to part B and part F with 4pcs bolts L and 4pcs washers N, using Allen wrench P. Note: Please fully tighten all the bolts.

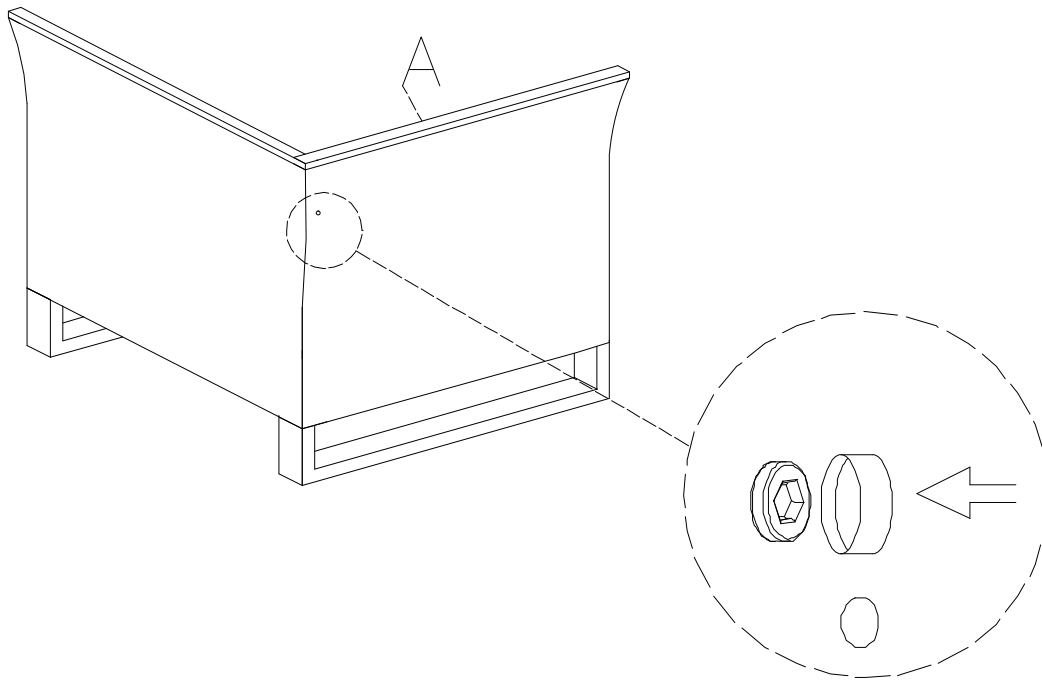

L		M6*40	4
N		M6	4

**Step 6:** Lock the bolt cap O to long back panel A.



		plastic cap D13*M6	1
---	---	-----------------------	---

**Step 7:** Put seat cushion I and back cushions G&H onto the seat .  
Assembly is now complete and the product is ready for use

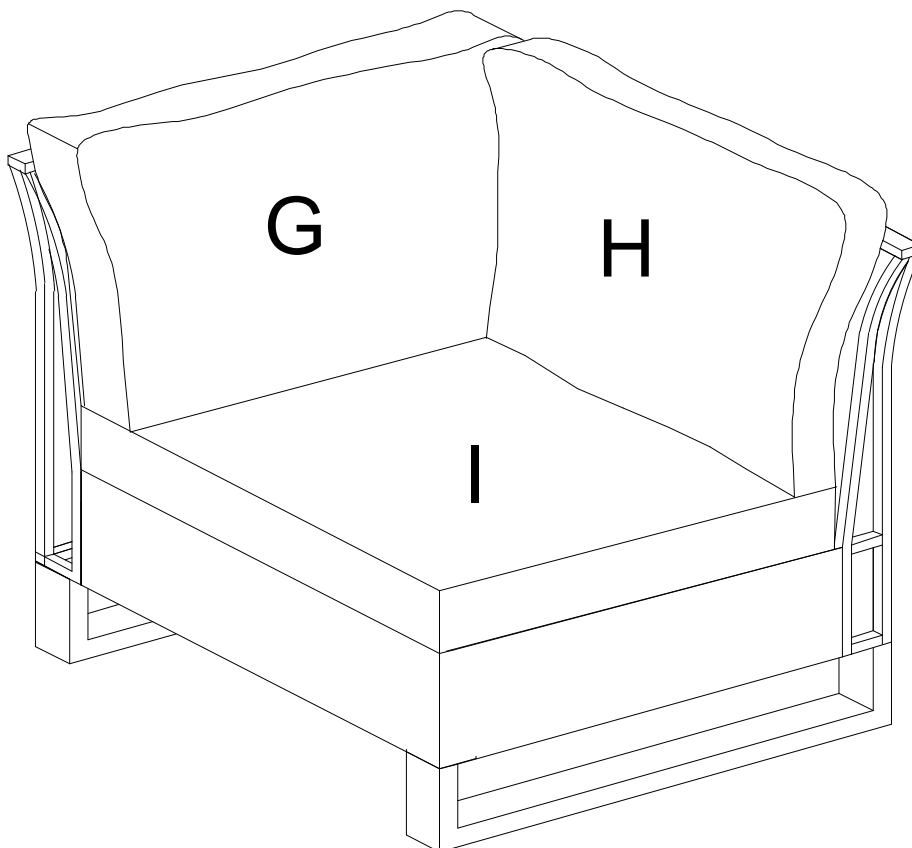

**Step 8:** Press the lock Q to bottom of front panel and side panel to connect the sofas.

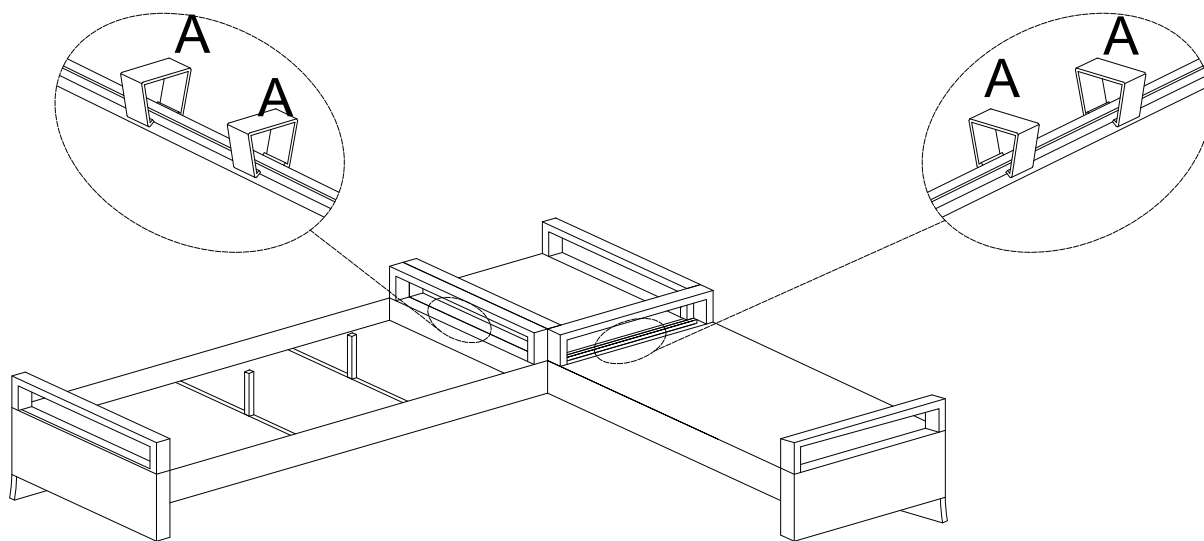

**Q**

67\*33\*H64 (C10)

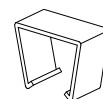

**4**