













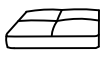



ASSEMBLY INSTRUCTIONS

Thank you for purchasing the quality product. Be sure to check all packing material carefully for small parts which may have come loose inside the carton during shipment. Separate, identify and count all parts and metal hardware. Compare with all parts list to be sure all parts are present. If any part(s) are missing or damaged, please contact your local furniture dealer. For efficient and speedy service, please indicate the model number and code letter of part(s) needed.

Do not fully tighten screws until fully assembled

Parts List			Qty	HARDWARE LIST			
A		SOFA SEAT	2pcs	1		Leg(85*65*130mm)	4pcs
B		BACKREST	2pcs	2		Leg(80*20*125mm)	2pcs
C		SEATCUSHION	2pcs	3		Bolt(M8*35mm)	4pcs
D		BACKCUSHION	2pcs	4		Bolt(M8*60mm)	4pcs
				5		Bolt(M8*80mm)	2pcs
				6		Bolt(M8*110mm)	2pcs
				7		Flat Wssher(M8)	12pcs
				8		Flat Wssher(ø30mm)	4pcs
				9		Flat Wssher(ø45mm)	4pcs
				10		NUT(M8)	4pcs
				11		Allen Wrench(M8)	1pc
				12		Allen Wrench(M4)	1pc

step1

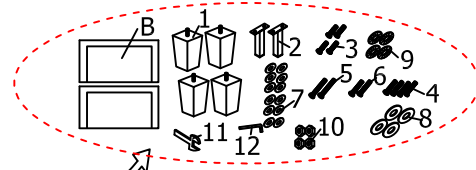

ALL COMPONENTS ARE INCLUDED UNDER THE SOFA

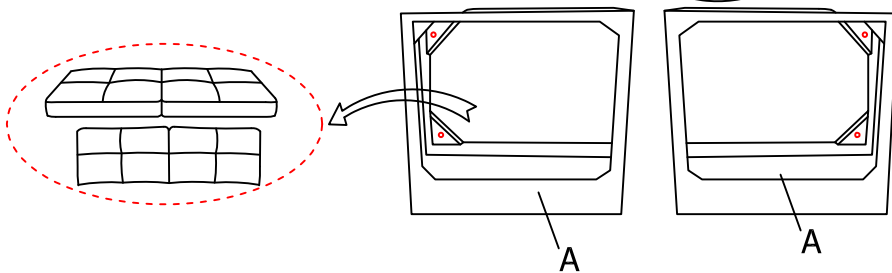

step2

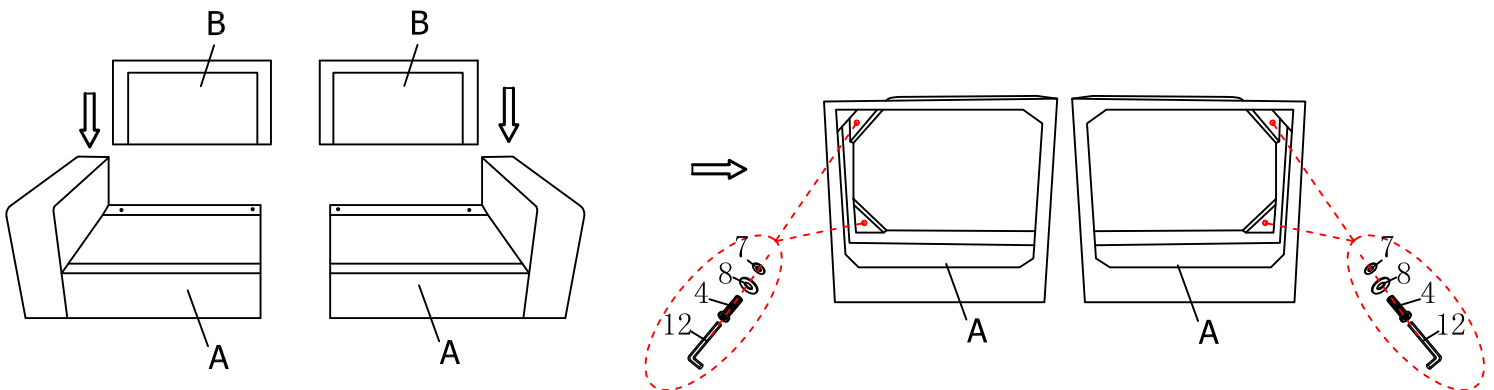

ASSEMBLY INSTRUCTIONS

step3

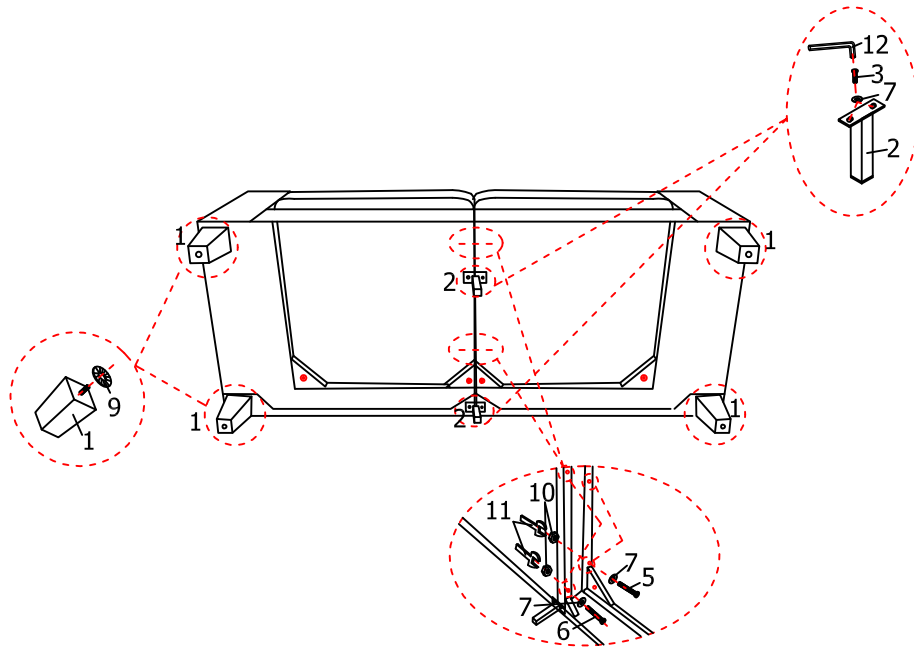

step4

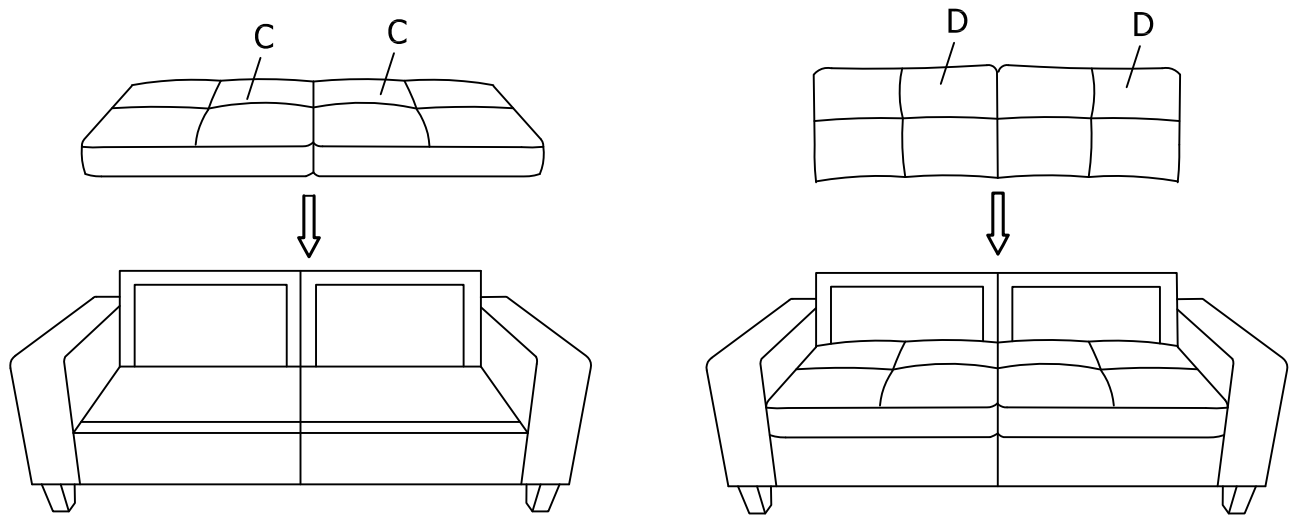

step5

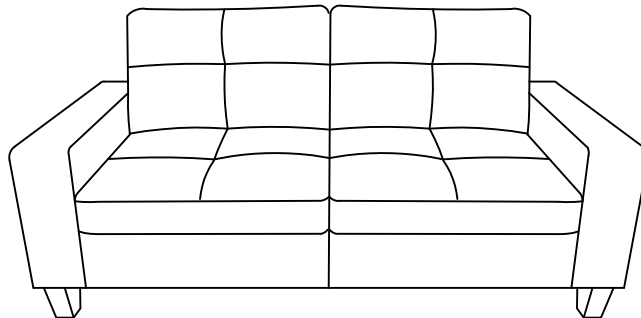

MADE IN CHINA