

Assembly Instructions
Instrucciones De Ensamblaje
Instructions D'Assemblage



Please mention model # SOC056_217B_V1



877-472-4296

www.medalsports.com

LIMITED 90 DAYS WARRANTY

This product is covered by a limited warranty that is effective for 90 days from the date of purchase. If, during the limited warranty period, a part is found to be defective or breaks, we will offer replacement parts at no cost to you, the customer. The only exceptions to the warranty include mainframes, table tops, playing surfaces, batteries or tools.

The above warranty will not apply in cases of damages due to improper usage, alteration, misuse, abuse, accidental damage or neglect.

This Limited Warranty gives you specific legal rights and you may also have other rights vary from one State (province) to another.

A PURCHASE RECEIPT (or other proof of purchase) will be required before any warranty service is initiated. For all requests for warranty service, please feel free to contact our Consumer Service Department.

Please be aware of your product's Limited Warranty for the return/refund policy from the store. We, at Medal Sports, cannot handle the product which is out of product's limited warranty since we only provide available parts. Thank you!

PLEASE CONTACT US BEFORE RETURNING THE PRODUCT TO THE STORE!

GARANTIE LIMITEE DE 90 JOURS

Este producto está cubierto por una garantía efectiva de 90 días a partir de la fecha de su compra. Durante el período límite de la garantía, si una parte defectuosa o quebrada es encontrada, nosotros ofreceremos una reparación o un reemplazo de la partes sin ningún costo para ud, nuestro cliente. Las únicas excepciones de la garantía incluyen unidad principales, tableros de mesa, superficies, pilas o herramientas.

La susodicha garantía no se aplicará en los casos de daños y perjuicios debido al uso impropio, la alteración, el mal uso, el abuso, el daño accidental o la negligencia.

Esta garantía limitada le da a usted derechos legales específicos, usted también puede tener otros derechos que varían de un estado (provincia) a otro.

EL RECIBO DE LA COMPRA (U otra prueba de compra) sería requerida antes que cualquier servicio de garantía fuera iniciada. Para todo pedido por servicio de garantía, por favor siéntase libre de ponerse en contacto con nuestro Departamento de Servicio de Consumidor.

Por favor tenga atención sobre el Límite de Garantía de su producto de la política de vuelta/reembolsa desde la tienda. Nosotros, Medal Sports, no podemos manejar el producto que está fuera del límite de garantía ya que proporcionamos solamente partes disponibles. ¡Gracias!

¡POR FAVOR PÓNGASE EN CONTACTO CON NOSOTROS ANTES DE DEVOLVER EL PRODUCTO A LA TIENDA!

GARANTÍA LIMITA DE 90 DIAS

Ce produit est couvert par une garantie limitée valable 90 jours à compter de la date d'achat. Si pendant cette période une pièce est jugée défectueuse ou se casse, nous la remplacerons gratuitement. Les seules exceptions à la garantie comprennent les armatures principales, les dessus de table, les surfaces de jeu, les piles ou les outils.

La garantie ci-dessus ne s'applique pas en cas de dommages occasionnés par une mauvaise utilisation, une altération du produit, de mauvais traitements, des dommages accidentels ou des négligences.

Cette garantie limitée vous accorde des droits légaux spécifiques ainsi que d'autres droits variant d'un état (province) à un autre.

UNE FACTURE D'ACHAT (ou toute autre preuve d'achat) sera exigée avant toute intervention sous garantie. Pour toute demande d'intervention sous garantie, veuillez contacter notre Service à la Clientèle.

Comprennez notre garantie produit limitée en ce qui concerne notre politique de retour/remboursement depuis votre magasin. Ici à Medal Sports, nous ne pouvons prendre un compte un produit qui n'est plus sous garantie puisque nous ne pouvons que fournir les pièces disponibles. Remerciements!

VEUILLEZ NOUS CONTACTER AVANT DE RETOURNER LE PRODUIT EN MAGASIN!



WE ARE READY TO HELP

DO NOT RETURN TO STORE

ESTAMOS LISTOS PARA AYUDAR

NO DEVOLVERLO A LA TIENDA

NOUS SOMMES PRÊTS À VOUS AIDER

NE PAS RAPPORTER EN MAGASIN

Please Contact

Por favor Contacto

Veillez contacter

MD SPORTS

Customer Service
Toll Free

Servicio al Cliente
Llamados gratuitos

Service Clientèle
N° Vert

877-472-4296

Mon.-Fri.,
9:00 a.m. to 5:00 p.m. EST

Lunes a Viernes,
9:00 a.m. a 5:00 p.m. ET

Du lundi au vendredi de
9:00 a 17 heures HNE

For additional resources and
Frequently Asked Questions,
please visit us at

Por mayor información y
Preguntas Frecuentes, favor
visitarnos en

Pour toute information
complémentaire ou réponse
aux questions fréquentes
veuillez vous rendre sur

www.medalsports.com

TOOLS REQUIRED

Phillips Screwdriver - **Not Included**
Standard (Flat Head - **Not Included**
Screwdriver)
Wrench - **Included**

HERRAMIENTAS NECESARIAS

Destornillador Phillips - **No incluido**
Destornillador de
Cabeza Plana - **No incluido**
Llave Inglesa - **Incluido**

OUTILS REQUIS

Tournevis cruciforme - **Non inclus**
Tournevis standard - **Non inclus**
(Tête plate)
Clé anglaise - **Incluse**

**RECOMMENDED**

Electric Screwdrivers may be helpful during assembly; however, please set a low torque and use extreme caution.

**RECOMENDADO**

Los destornilladores eléctricos pueden ser de gran ayuda durante el ensamblado; sin embargo, por favor ajuste el par de giro bajo y sea extremadamente precavido.

**RECOMMANDÉ**

Un tournevis électrique peut être utile pour l'assemblage; utilisez cependant une vitesse de rotation lente et avec prudence.



Power Tools: **Set to Low Torque**
/ Herramientas eléctricas: **Bajo par**
/ Outillage électrique: **Régler sur rotation lente**



High Torque: **Over Tightened**
/ Alto par: **más estrictas**
/ Rotation rapide: **Trop serré**

IMPORTANT NOTICE!

1. This product is intended for INDOOR use only.
2. Please do not sit, climb or lean on the product.
3. Please do not drag the product when moving it in order to avoid damaging the legs.
4. Please only use spray furniture polish to clean the exterior surfaces of the product.
5. This is not a child's toy, adult supervision is required for children playing this game.

¡AVISO IMPORTANTE!

1. Este producto está destinado para el uso INTERIOR solamente.
2. Por favor no sientes, subas o inclines el producto.
3. Por favor no arrastres el producto cuando está moviendo para evitar el daño sobre las piernas.
4. Por favor use solamente spray para muebles para limpiar la superficie exterior del producto.
5. Esto no es un juguete de niños, se requieren la supervisión adulta para niños cuando esté jugando al juego.

NOTE IMPORTANTE!

1. Ce produit est conçu pour une utilisation en intérieur uniquement.
2. Veuillez ne pas vous asseoir, grimper ou vous appuyer sur la produit.
3. Veuillez ne pas trainer ce produit quand vous le déplacez pour éviter d'endommager les pieds.
4. Veuillez n'utiliser que du poli à meubles en aérosol pour nettoyer les surfaces extérieures du produit.
5. Ceci n'est pas un jeu d'enfant et la surveillance d'adultes est requise pour les enfants jouant à ce jeu.



At least 2 adults needed

Se necesitan al menos 2 adultos

Il faut au moins 2 adultes



No children in assembly area

No deben estar los niños en el area de ensamble

Pas d'enfants dans la zone d'assemblage



Keep away from pets in assembly area

Mantener alejados a los animales domesticos del area de ensamble

Tenir les animaux de compagnie à distance



Do not use or keep product outdoors. For indoor use only. No wet/humid conditions.

No usar o guardar el producto en el exterior. Solo para uso en interior. No utilizar ni guardar el producto en lugares húmedos o mojados

N'utilisez ni ne stockez ce produit en extérieur. Uniquement pour utilisation en intérieur. Ne pas exposer à l'humidité

WARNING

Adult Assembly Required.
CHOKING HAZARD - This item contains small parts or / and small balls. Not suitable for children under 3 years.

ADVERTENCIA

El ensamblaje debe ser realizado por un adulto.
PELIGRO DE ASFIXIA - Este artículo contiene piezas pequeñas y / o pequeñas bolas. No es apto para niños menores de 3 años de edad.











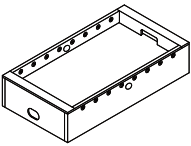

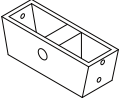
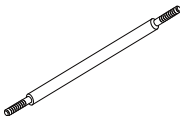
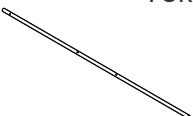
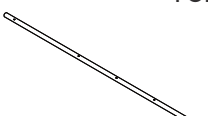
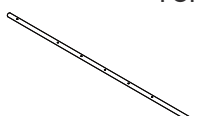
AVERTISSEMENT

L'assemblage doit être effectué par des adultes.
RISQUE D'ASPHYXIE - Ce produit contient de petites pièces et / ou de petites boules. Ne convient pas à des enfants de moins de 3 ans.

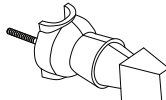
PARTS IDENTIFIER

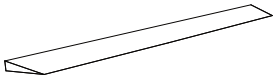
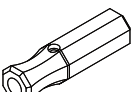
IDENTIFICADOR DE PIEZAS

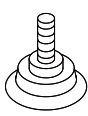
IDENTIFICATEUR DE PIÈCES

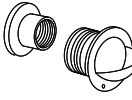
PART NUMBER NÚMERO DE PIEZA NUMÉRO D'ARTICLE			1 FOR FIG. 3 			FIG NUMBER NÚMERO DE FIG NUMÉRO FIG					
PART PIEZA PIÈCE			x1			QUANTITY CANTIDAD QUANTITÉ					
PART NAME			Mainframe	Unidad Principal	Unité centrale	NOM DE LA PIÈCE NOMBRE DE PIEZA					
2 FOR FIG. 1 			3 FOR FIG. 1 			4 FOR FIG. 2 					
x4			x2			x1					
Leg	Pierna	Pied	End Leg Panel	PaPanel de Pierna Finalierna	Panneau pied inférieur	Cross bar	Barra transversal	Barre transversale	Slide Scorer	Resbaladilla de Marcador	Marqueur à main
6 FOR FIG. 5 			7 FOR FIG. 5 			8 FOR FIG. 5 			9 FOR FIG. 6 		
x2			x4			x2			x13		
2-Hole Rod	Barra de 2 Agujeros	Tige à 2 trous	3-Hole Rod	Barra de 3 Agujeros	Tige à 3 trous	5-Hole Rod	Barra de 5 Agujeros	Tige à 5 trous	Player Head-Gray	Jugador Cabeza-Grís	Tête Lecteur-Grís
10 FOR FIG. 6 			11 FOR FIG. 6 			12 FOR FIG. 6 			13 FOR FIG. 6 		
x13			x13			x13			x13		
Player Head-Black	Jugador Cabeza-Negro	Tête Lecteur-Noir	Player Front-Gray	Jugador Delantero -Grís	Lecteur avant-Grís	Player Front-Black	Jugador Delantero -Negro	Lecteur avant-Noir	Player Back-Gray	Jugador Trasero-Grís	Lecteur Arrière-Grís
14 FOR FIG. 6 			15 FOR FIG. 4 			16 FOR FIG. 7 			17 FOR FIG. 5 		
x13			x2			x8			x16		
Player Back-Black	Player Back-Negro	Lecteur Arrière-Noir	Playfield Ramp	Rampa de Cancha de Juego	Rampe Terrain de Jeu	Handle	Mango	Poignée	Rod Washer	Arandela de Barra	Rondelle de tige
18 FOR FIG. 5 			19 FOR FIG. 2 			20 FOR FIG. 7 			21 FOR FIG. 9 		
x16			x4			x8			x2		
Rod Bumper	Bómpier de Barra	Amortisseur Tige	Leg Leveler	Nivelador de Pierna	Niveleur de Pied	Rod End Cap	Corra de Barra Final	Capuchon bout de tige	Plastic Ball Entry Rim	Llanta de Entrada de Pelota Plástica	Bord d'entrée du ballon plastique

ACCESSORIES

ACCESORIOS







ACCESSOIRES

22 		
x2		
Soccer ball	Bola de Fútbol	Ballon de Foot

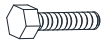
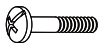
HARDWARE

HARDWARE

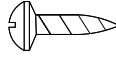
MÉTAUX

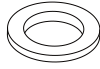
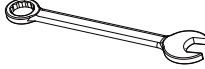
A1 FOR FIG. 3			A2 FOR FIG. 7			A3 FOR FIG. 1			A4 FOR FIG. 1, 3		
											
x16			x8			x8			x24		
5/16" X 1-1/2" Bolt	Perno 5/16" X 1-1/2"	Boulon 5/16" X 1-1/2"	T5x5/8" Bolt	Perno T5x5/8"	Boulon T5x5/8"	5/16" X 5/8" Bolt	Perno 5/16" X 5/8"	Boulon 5/16" X 5/8"	5/16" Washer	Arandela 5/16"	Rondelle 5/16"
A5 FOR FIG. 8			A6 FOR FIG. 9			A7 FOR FIG. 1, 3			A8 FOR FIG. 2		
											
x4			x2			x24			x2		
F4x2" Screw	Tornillo F4x2"	Vis F4x2"	4x5/8" Screw	Tornillo 4x5/8"	Vis 4x5/8"	5/16" Spring lock Washer	Arandela de cerradura de resorte 5/16"	Rondelle de bloqueo 5/16"	M33 Nut	Tuerca M33	Ecrou M33
A9 FOR FIG. 2			A10								
											
x4			x1								
1-3/8" Washer	Arandela 1-3/8"	Rondelle 1-3/8"	Wrench	Llave Inglesa	Clé anglaise						

PRE-INSTALLED PARTS

PIEZAS PREINSTALADAS

PIÈCES PRÉINSTALLÉES

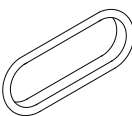
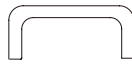
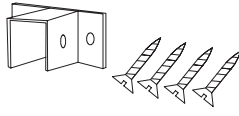
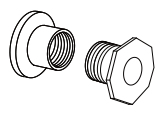
P1 FOR FIG. 4			P2 FOR FIG. 4			P3 FOR FIG. 3			P4 FOR FIG. 3		
											
x2			x2			x2			x16		
Ball Return Cover	Cubierta de Retorno de Bola	Cache Retour de Balle	Goal Cover	Cubierta de Gol	Cache But	Square Nut with Screws	Tuerca Cuadrada con Tornillos	Écrou carré avec vis	Plastic Rod Bushing	Cojinete de Barra Plástica	Manchon de la tige plastique

BEFORE ASSEMBLY

ANTES DE MONTAR

AVANT L'ASSEMBLAGE

1. Find a clean, level place to begin the assembly of your product.
2. Verify that you have all listed parts as shown on the part list pages. If any parts are missing, call our customer service.

1. Encuentre un lugar limpio y nivelado para comenzar el ensamblaje del producto.
2. Compruebe que tenga todas las piezas que se muestran en la lista de piezas. Si falta alguna pieza, llame a nuestro servicio al cliente.







1. Trouvez un endroit propre et plat pour commencer à assembler votre produit.
2. Vérifiez que vous avez toutes les pièces énumérées comme indiqué sur les pages de liste des pièces. S'il y a des pièces qui manquent, appelez notre service clientèle.

ASSEMBLY

MONTAJE

ASSEMBLAGE

FIG. 1

- | | | |
|-----|---|----|
| 2 |  | x4 |
| 3 |  | x2 |
| A3 |  | x8 |
| A4 |  | x8 |
| A7 |  | x8 |
| A10 |  | x1 |

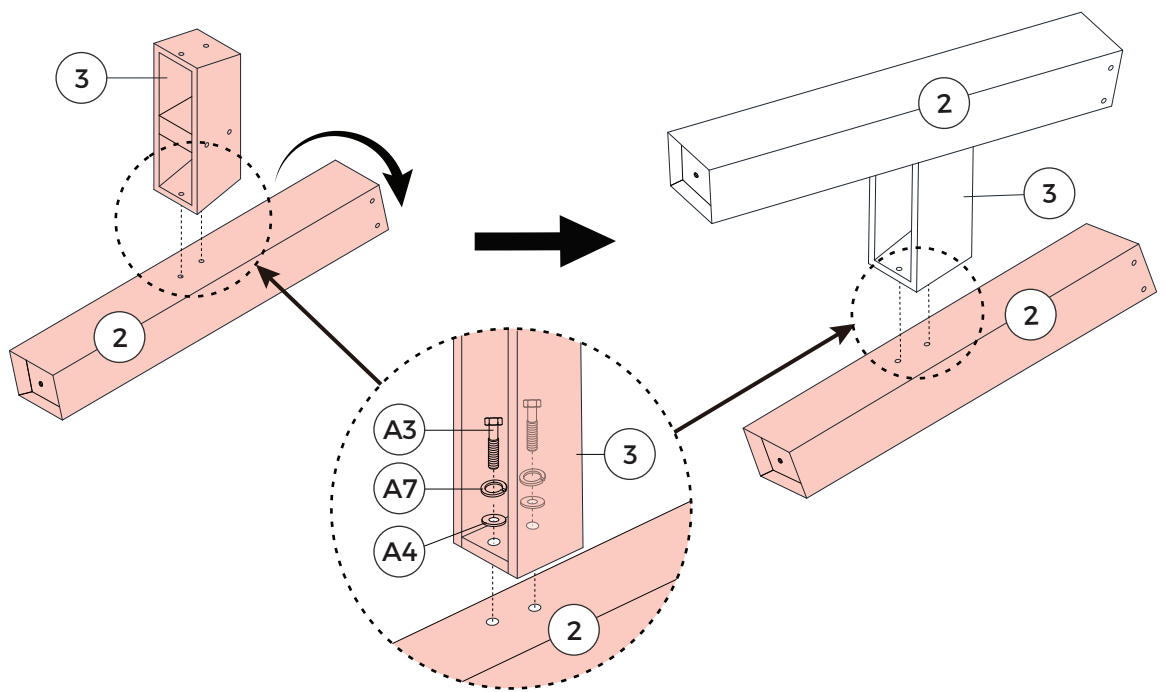



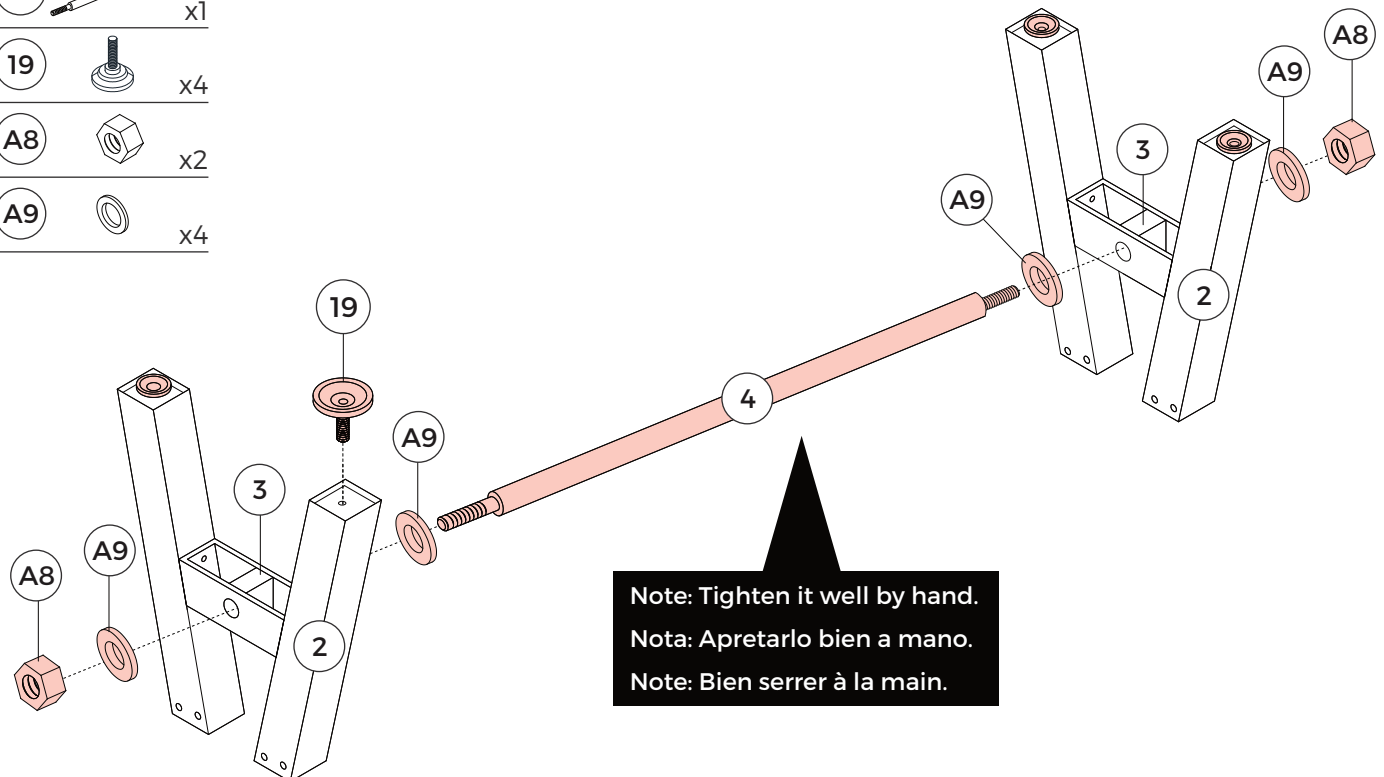

FIG. 2

- | | | |
|----|---|----|
| 4 |  | x1 |
| 19 |  | x4 |
| A8 |  | x2 |
| A9 |  | x4 |



Note: Tighten it well by hand.
 Nota: Apretarlo bien a mano.
 Note: Bien serrer à la main.

ASSEMBLY

MONTAJE

ASSEMBLAGE

FIG. 3

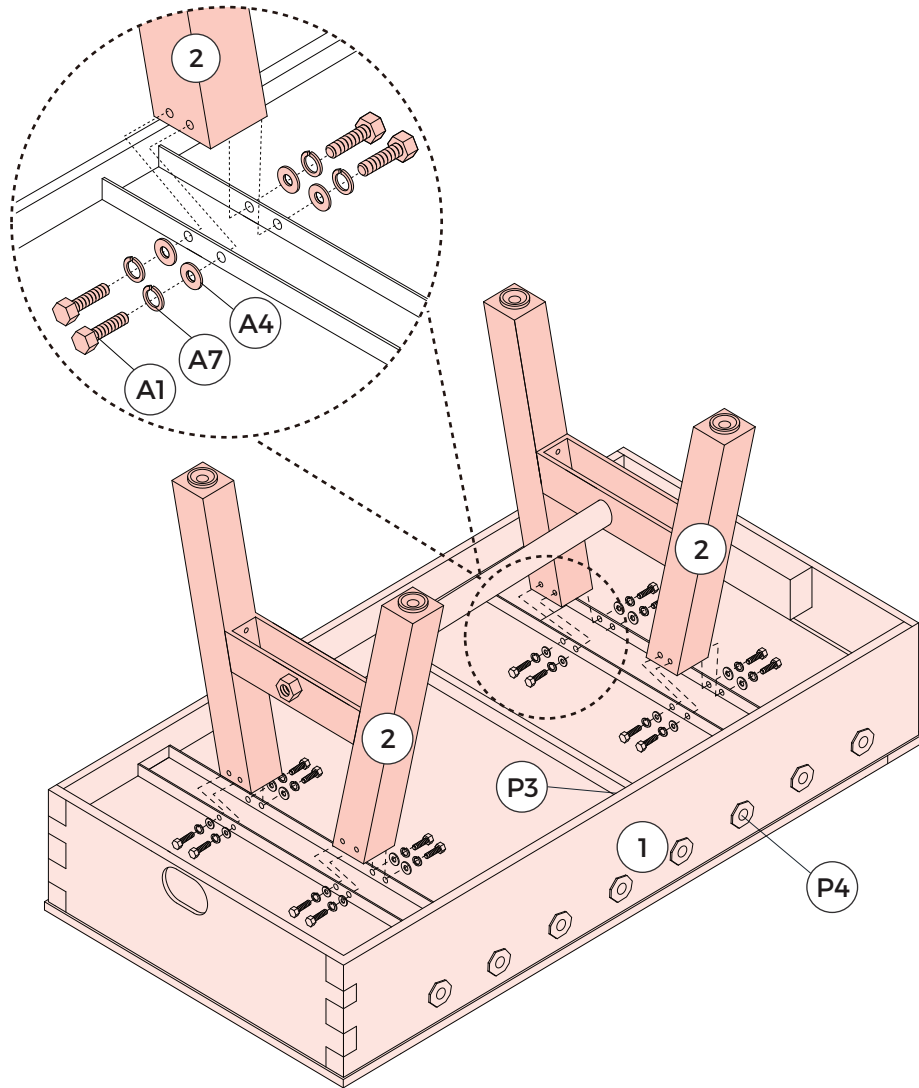
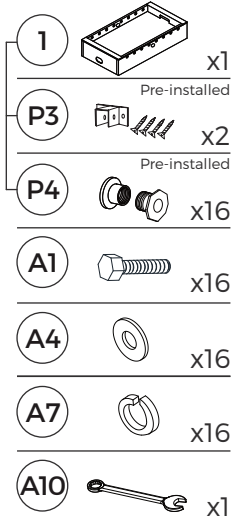

Note: Go back and make sure that all connections are tight.
Nota: Vuelva y asegúrese que todas las conexiones están apretadas.
Note: Revérifiez que toutes les connexions sont bien serrées.

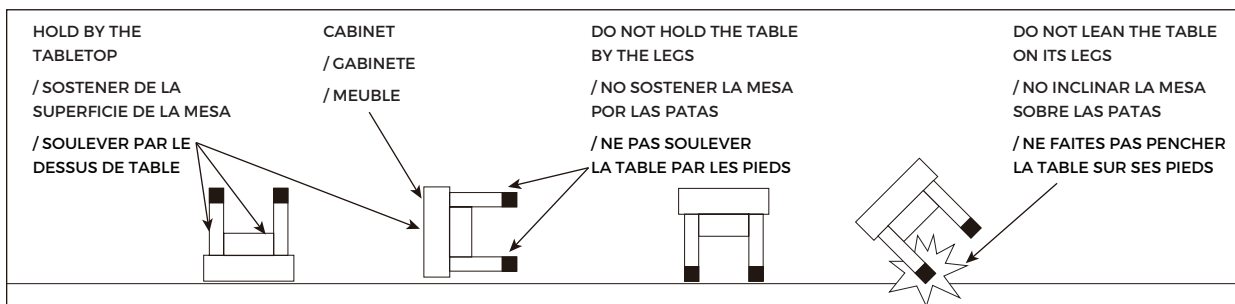
⚠ CAUTION

Two strong adults are recommended to turn over the table as shown.

1. Lift the table off the ground.
2. Turn the table over.
3. Place it on all four feet at the same time on the ground.

⚠ PRECAUCIÓN

Se recomienda la participación de dos adultos para invertir la mesa como se muestra.

1. Levantar la mesa del suelo.
2. Voltee la mesa.
3. Coloque las cuatro patas de la mesa sobre el piso al mismo tiempo.

⚠ ATTENTION

La présence de Deux adultes robustes est recommandée pour tourner la table comme sur Fig.



1. Soulevez la table du sol.
2. Retournez-la.
3. Placez ses quatre pieds sur le sol simultanément.

ASSEMBLY

MONTAJE

ASSEMBLAGE

FIG. 4

- 15  x2
- P1  x2
Pre-installed
- P2  x2
Pre-installed

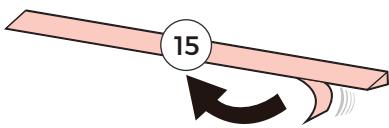

Note: Tear off the backside papers underneath the Playfield Ramps.

Nota: Remover los papeles traseros debajo de las Rampas de Cancha de Juego.

Note: Retirer le papier verso sous les rampes de terrain de jeu.

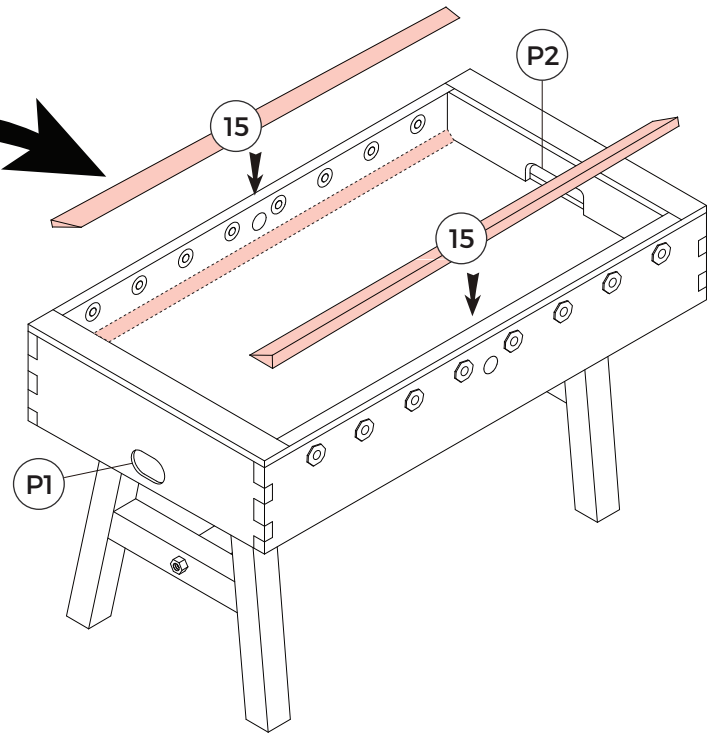

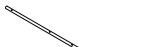



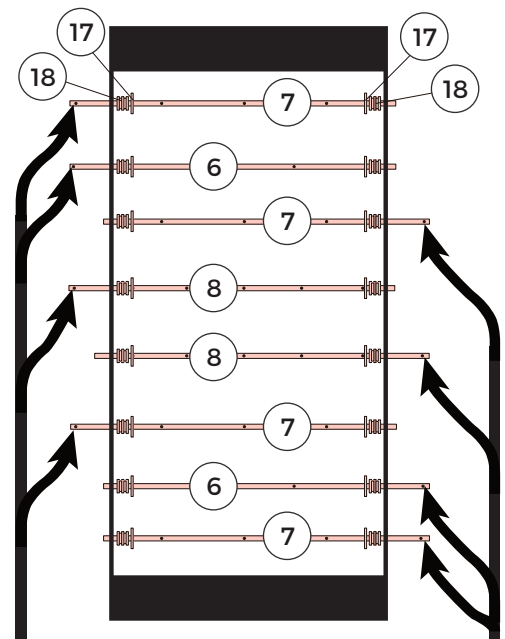
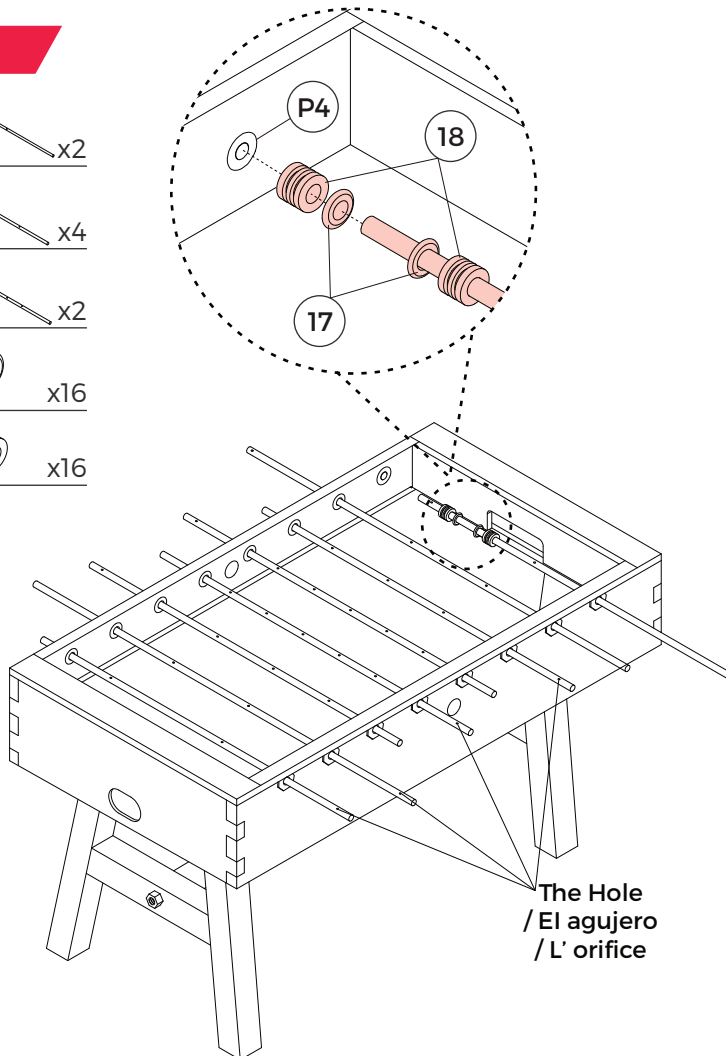

FIG. 5

- 6  x2
- 7  x4
- 8  x2
- 17  x16
- 18  x16



Note: Hole at the end of Rod designates handle location. See Arrow Location Below.

Nota: Agujero en el final de Barra se designa la posición de manija. Vea la Siguiente Posición de Flecha.

Note: L'orifice à l'extrémité d la Tige désigne l'emplacement de la poignée. Voir emplacement Flèche ci-dessous.

ASSEMBLY

MONTAJE

ASSEMBLAGE

FIG. 6

- 9  x13
- 10  x13
- 11  x13
- 12  x13
- 13  x13
- 14  x13

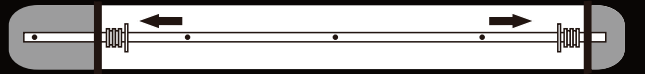

Note: Make sure 1 Rod Bumper and 1 Rod Washer are at each end of the Player Rods before adding Players.

Nota: Haga seguro que 1 Bómpfer de Barra y 1 Arandela de Barra están en cada final de las Barras de Jugador antes de agregar Jugadores.

Note: Assurez-vous qu'il y a bien un amortisseur et une rondelle à chaque extrémité des tiges joueurs avant d'ajouter les joueurs.

Order of players
(Overhead View)
/ Orden de jugador
(Vista en General)
/ Placement des joueurs
(Vue générale)

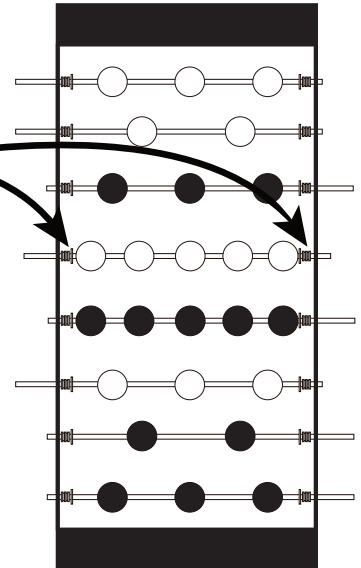

● = Black / Negro / Noir
○ = Gray / Gris / Gris

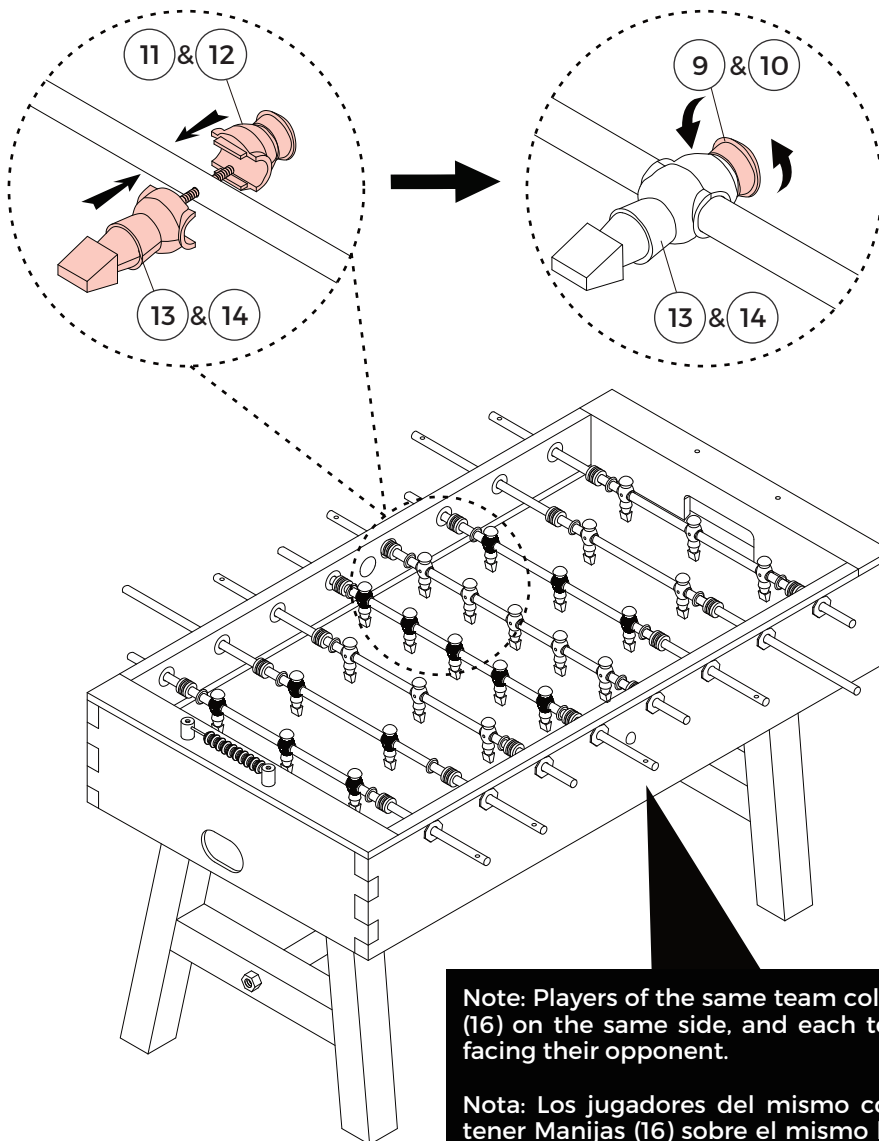

Note: Players of the same team color should have Handles (16) on the same side, and each team's player should be facing their opponent.

Nota: Los jugadores del mismo color de equipo debería tener Manijas (16) sobre el mismo lado, y los jugadores de cada equipo debería afrontar a su opositor.

Note: Les joueurs de la même couleur d'équipe doivent avoir leurs Poignées (16) du même côté et chaque équipe faire face à l'équipe opposée.

ASSEMBLY

MONTAJE

ASSEMBLAGE

FIG. 7

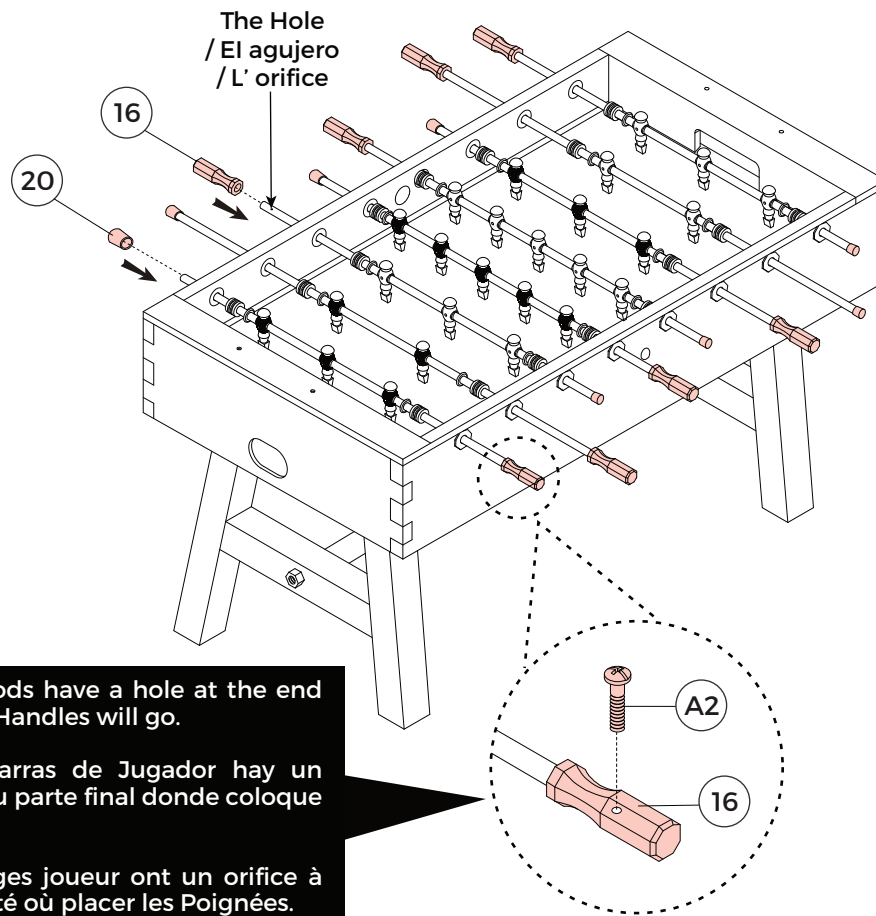
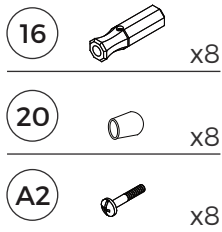
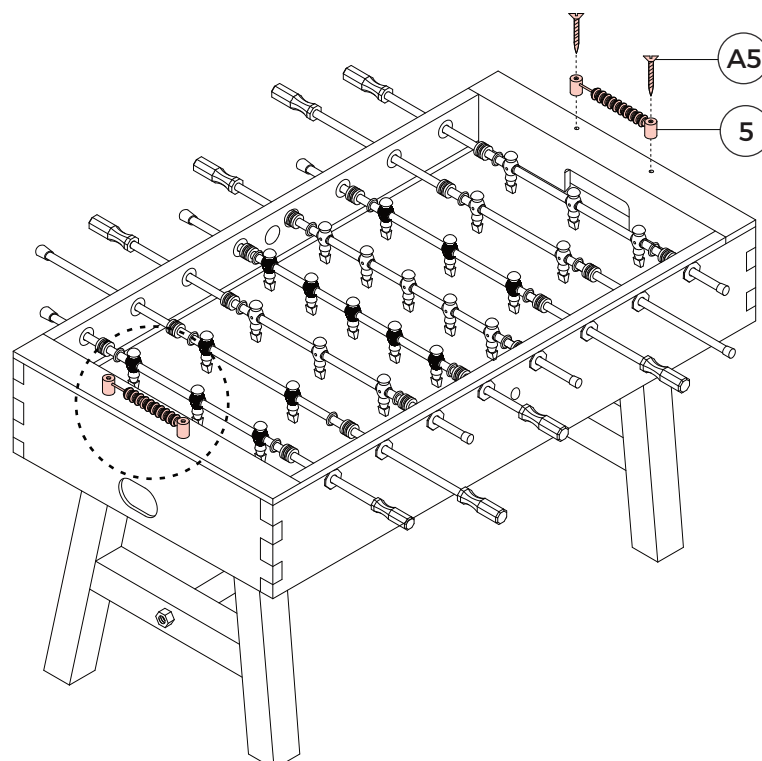
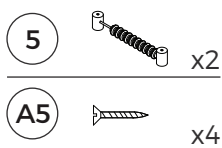

FIG. 8





ASSEMBLY

MONTAJE

ASSEMBLAGE

FIG. 9

- 21  x2
- A6  x2

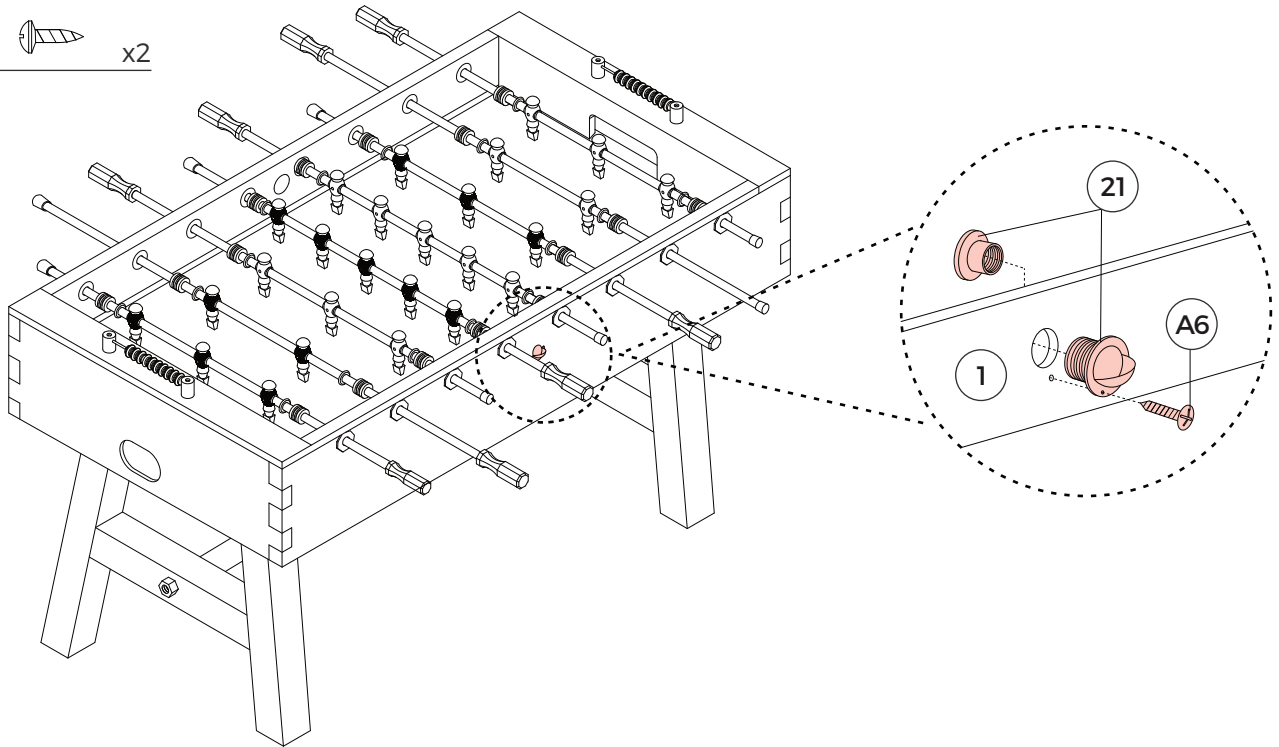



www.medalsports.com