

ASSEMBLY INSTRUCTIONS
COASTER FINE FURNITURE



Fine Furniture for every stage of life

800832
2 DRAWER CPU STAND

ITEM: **800832**



ASSEMBLY INSTRUCTIONS

ASSEMBLY TIPS:

1. Remove hardware from box and sort by size.
2. Please check to see that all hardware and parts are present prior to start of assembly.
3. Please follow attached instructions in the same sequence as numbered to assure fast & easy assembly.







WARNING!

1. Don't attempt to repair or modify parts that are broken or defective. Please contact the store immediately.
2. This product is for home use only and not intended for commercial establishments.



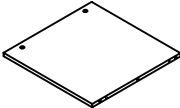

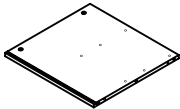
ASSEMBLY TIME

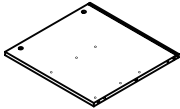
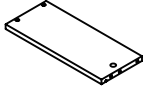
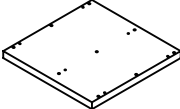
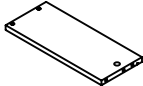
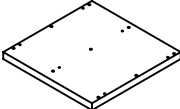
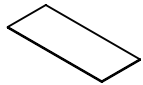
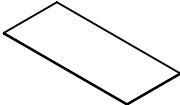
60 MINUTES

PARTS IDENTIFICATION

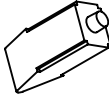
A	LEFT SIDE PANEL		1 PC	G	DRAWER FRONT PANEL		2 PCS
B	RIGHT SIDE PANEL		1 PC	H	DRAWER BACK PANEL		2 PCS
C	MIDDLE DIVIDER PANEL		1 PC	I	LEFT DRAWER SIDE PANEL		2 PCS
D	BOTTOM PANEL		1 PC	J	RIGHT DRAWER SIDE PANEL		2 PCS
E	TOP PANEL		1 PC	K	DRAWER BOTTOM PANEL		2 PCS
F	BACK PANEL		1 PC				

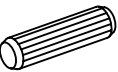
HARDWARE IDENTIFICATION

Z							
NO	DESCRIPTION	FIGURE	Q'TY	NO	DESCRIPTION	FIGURE	Q'TY
1	GLUE 40g		1 PC	3	SCREW Ø 4.5x42mm		6 PCS
2	WOODEN DOWEL Ø 8x30mm		26 PCS	4	CAM LOCK Ø 15x12mm		10 PCS

NOTE:

Phillips head screw driver is required in the assembly process; however, manufacturer does not provide this item.

ITEM: **800832**



HARDWARE IDENTIFICATION

Z							
NO	DESCRIPTION	FIGURE	Q'TY	NO	DESCRIPTION	FIGURE	Q'TY
5	CAM BOLT Ø 7x35.5mm		10 PCS	10	SCREW Ø 4.8x16mm		16 PCS
6	RAIL L = 270mm		2 SET	11	HANDLE L=50mm		2 PCS
7	SCREW Ø 3x12mm		24 PCS	12	BOLT Ø 4x21.5mm		4 PCS
8	LOCK CASTER Ø 50mm		2 PCS	13	SCREW Ø 4.2x35mm		8 PCS
9	CASTER Ø 50mm		2 PCS	14	STICKER Ø 20mm		2 PCS

Z6,Z8,Z9,Z10 not included in blister packaging.

STEP 1

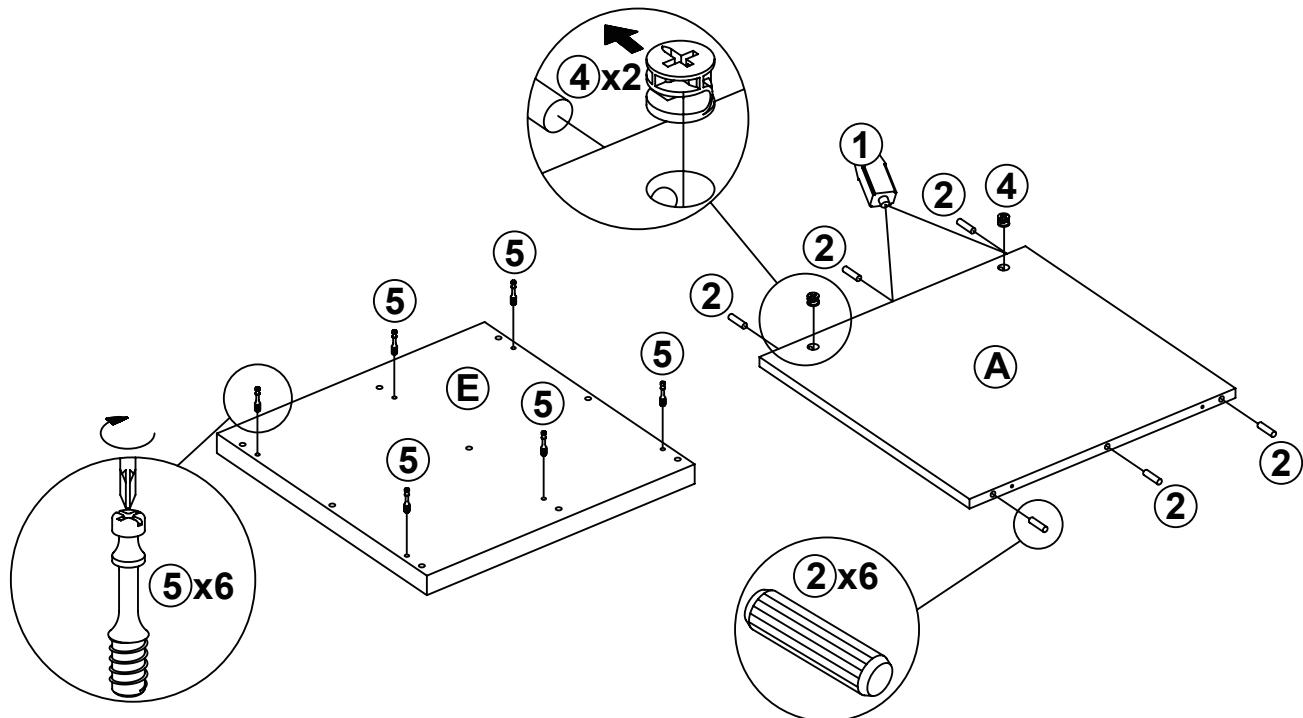

The Glue (1) should be used in the indicated locations to help solidify the assembled unit.

NOTE:

Phillips head screw driver is required in the assembly process; however, manufacturer does not provide this item.

ITEM: **800832**

STEP 2

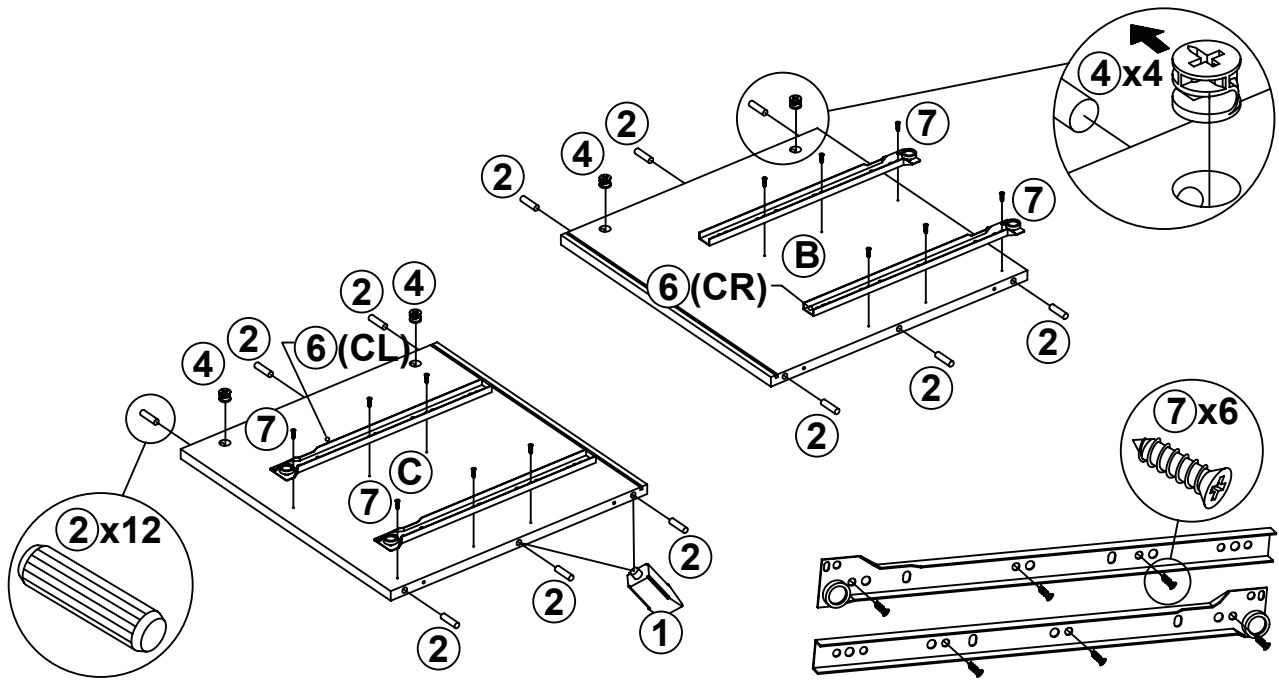

STEP 3

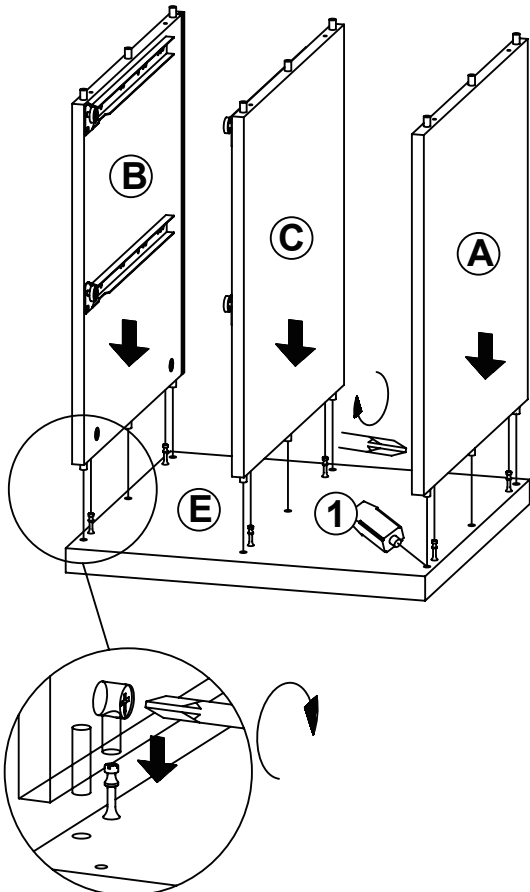

STEP 4

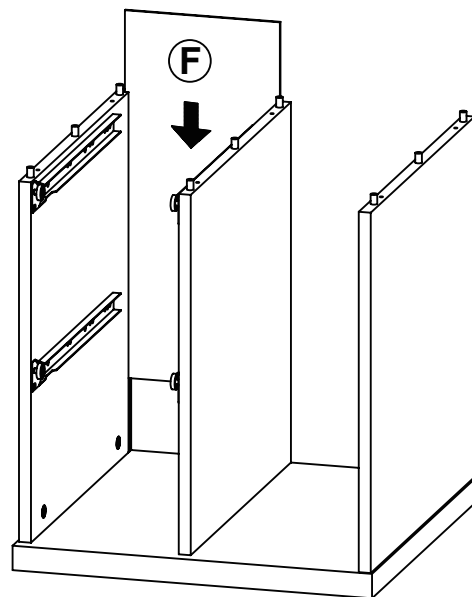

ITEM: **800832**

STEP 5

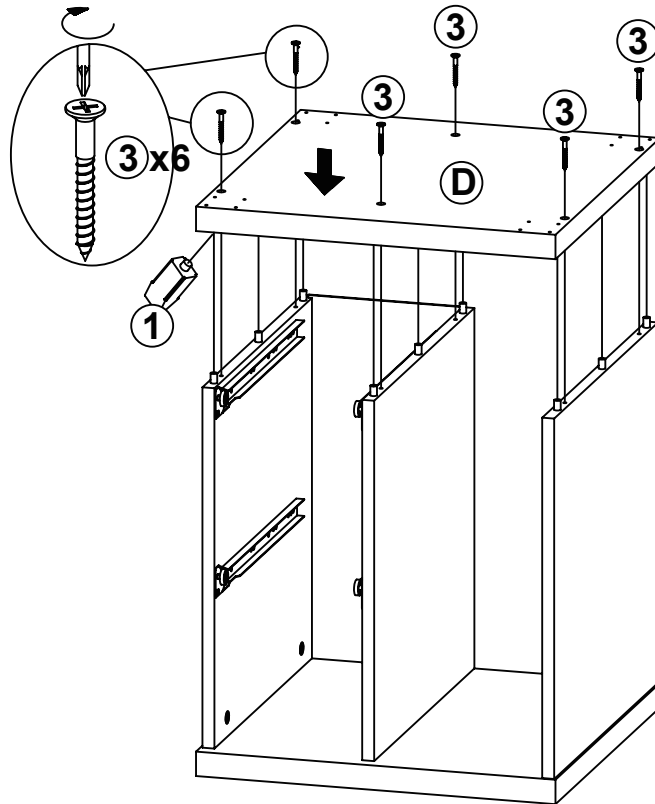

STEP 6

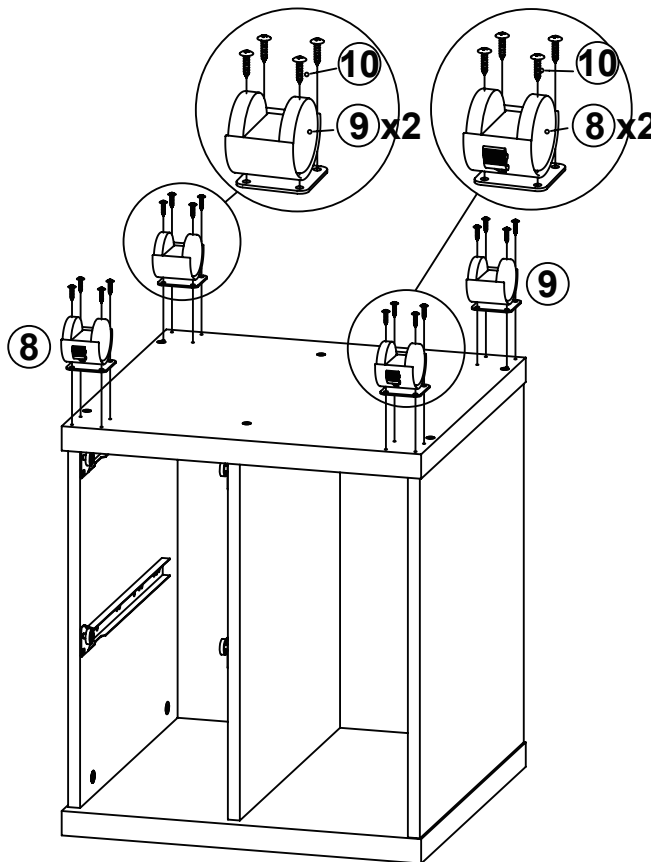

ITEM: **800832**

STEP 7

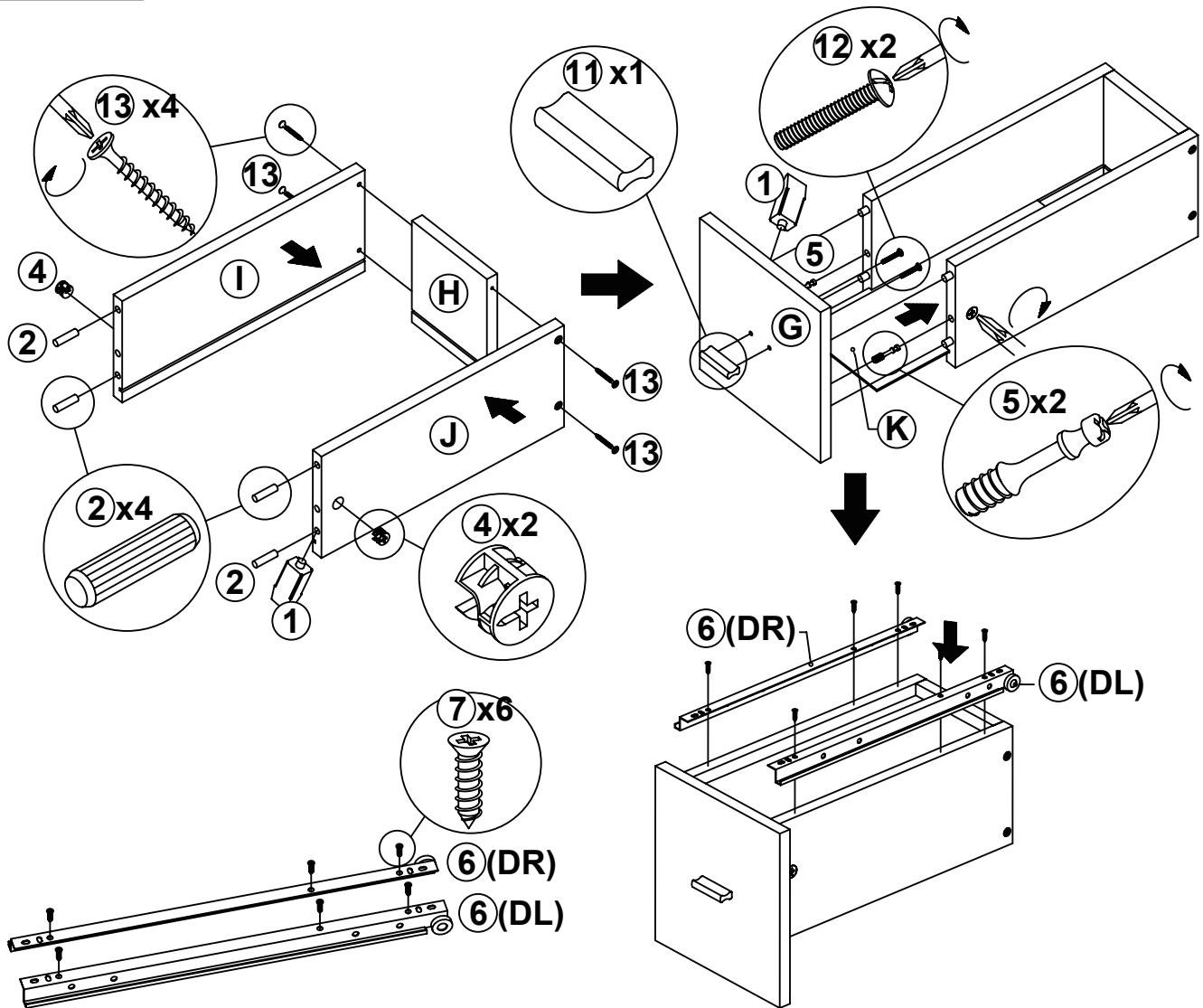

STEP 8

COMPLETE

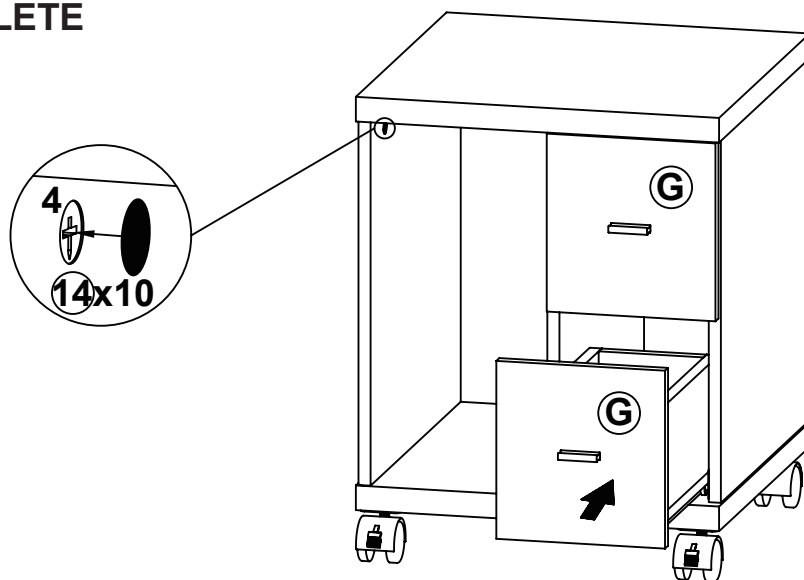

ITEM: 800832

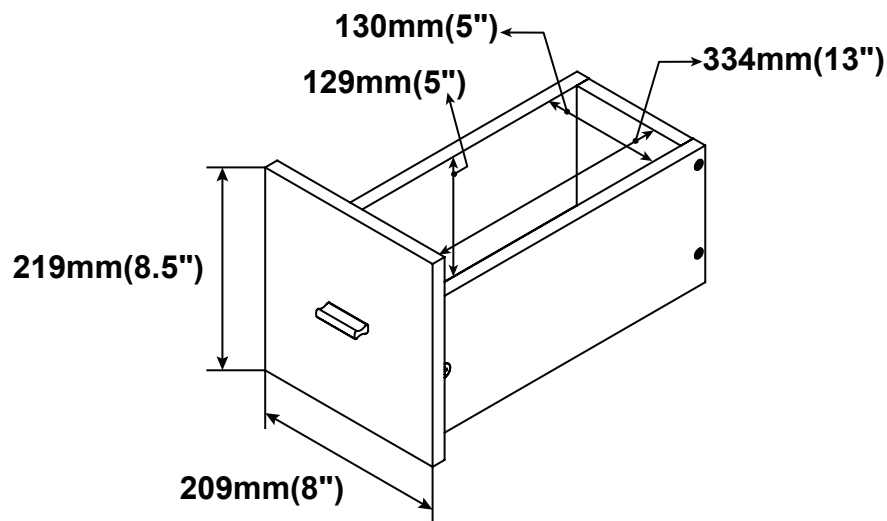
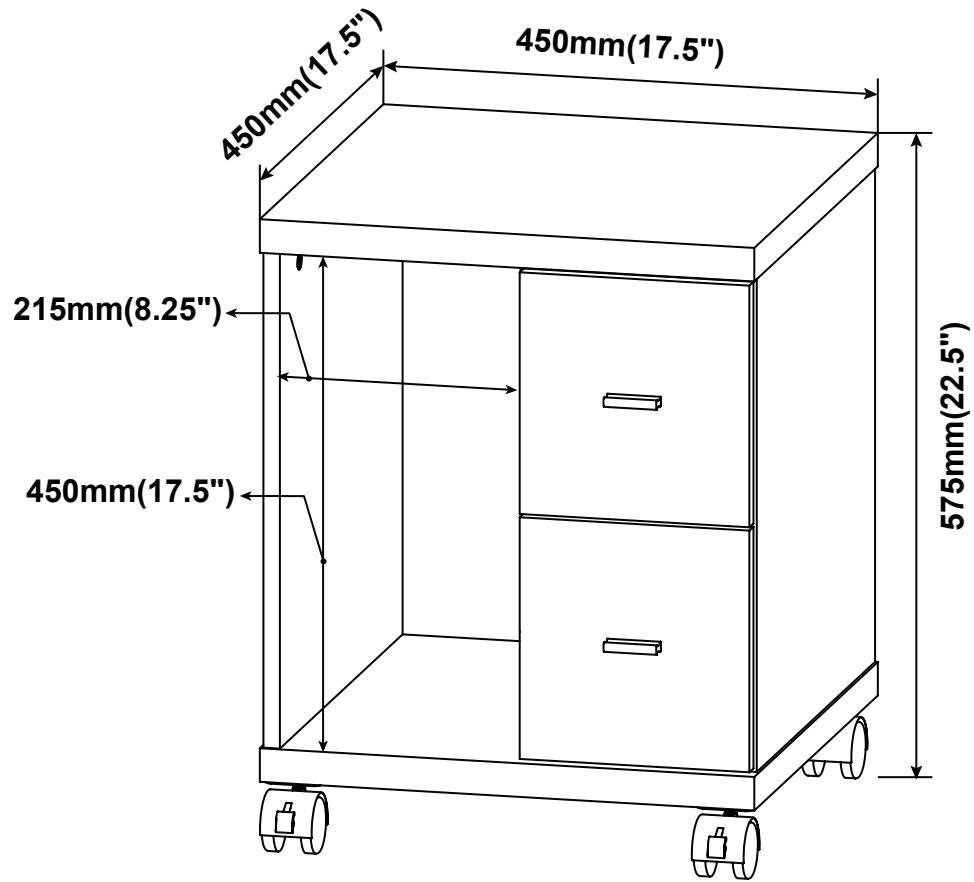

Note : Dimension tolerance $\pm 5\%$