

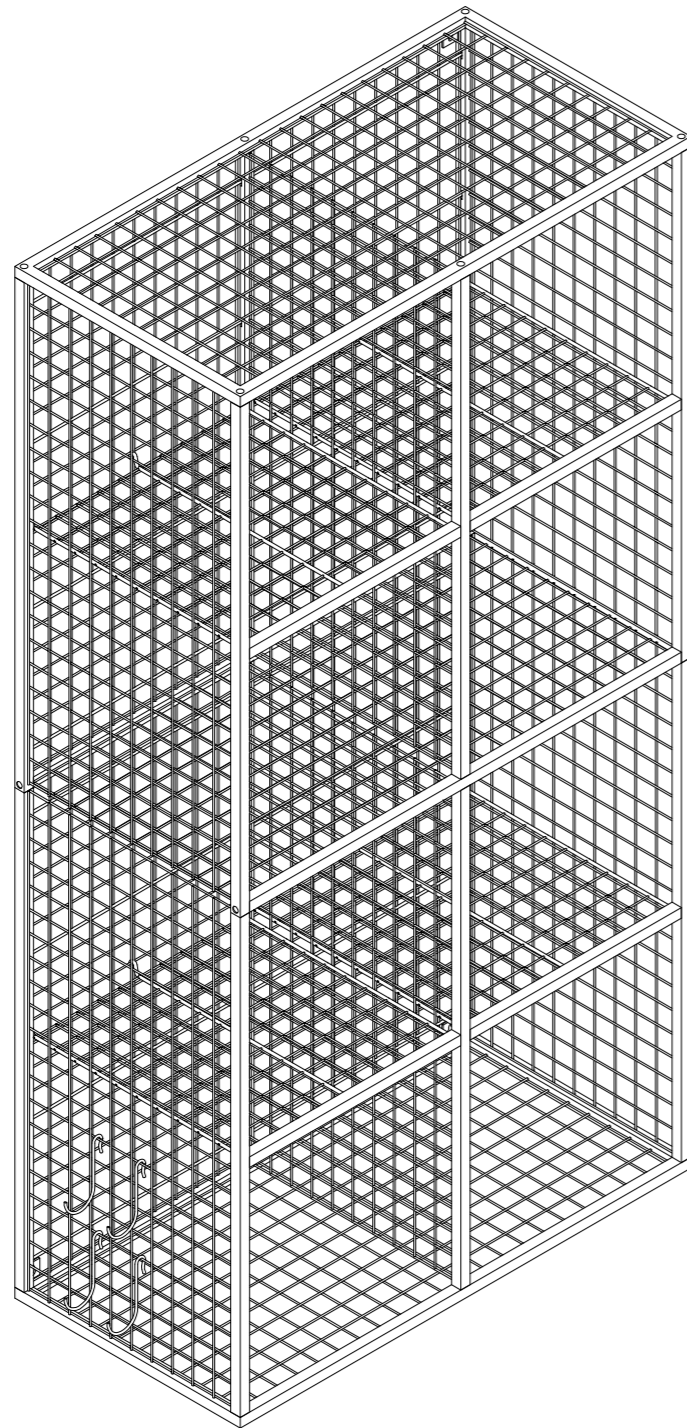

# ASSEMBLY INSTRUCTIONS

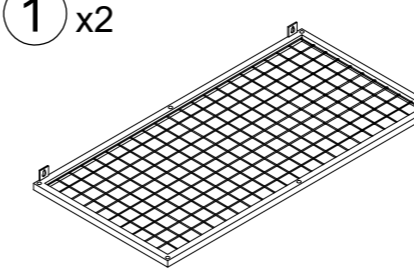
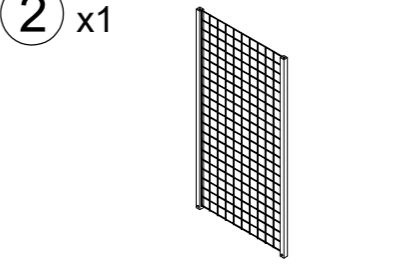
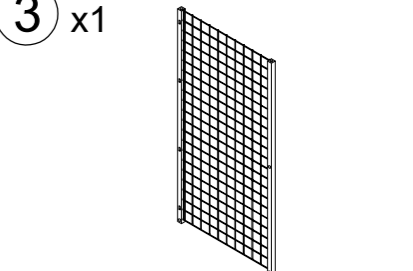
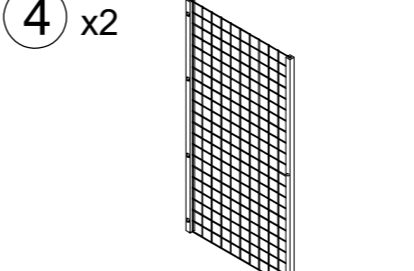
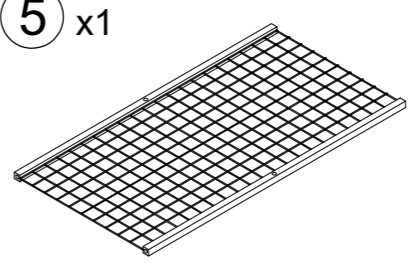
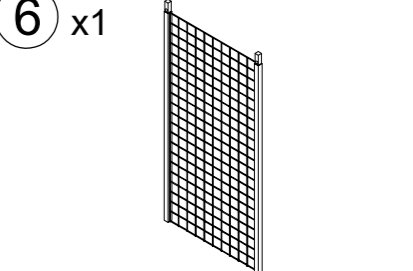
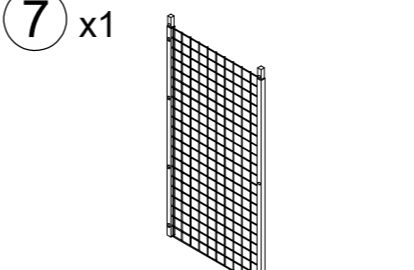
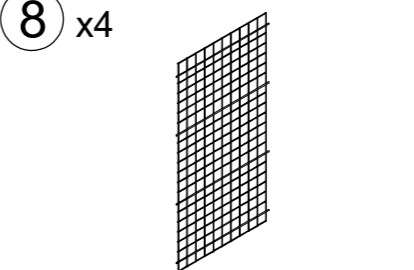
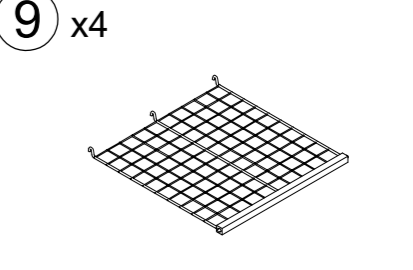

## PARTS LIST

<p>① x2</p> 	<p>② x1</p> 	<p>③ x1</p> 
<p>④ x2</p> 	<p>⑤ x1</p> 	<p>⑥ x1</p> 
<p>⑦ x1</p> 	<p>⑧ x4</p> 	<p>⑨ x4</p> 
<p>⑩ x4</p> 		

## HARDWARE LIST

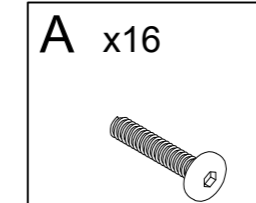
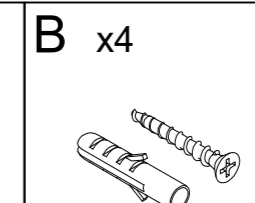
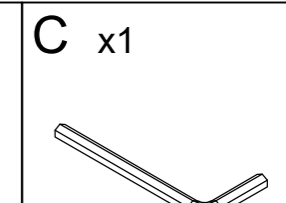
<p>A x16</p> 	<p>B x4</p> 	<p>C x1</p> 
<p>1/4 X 1</p>	<p>4.0 X 30</p>	

When the process of product assembly, please do not lock the screws at one time, but wait until all the screws are assembled to the position, and then straighten and flatten the product, and then tighten the screws of the same height in turn, so as to avoid unsmooth assembly and product tilt.



DURING THE ASSEMBLY PROCESS, DO NOT TIGHTEN ALL SCREWS AFTER ASSEMBLY, AND TIGHTEN ALL SCREWS.

# ASSEMBLY INSTRUCTIONS

## STEP 1

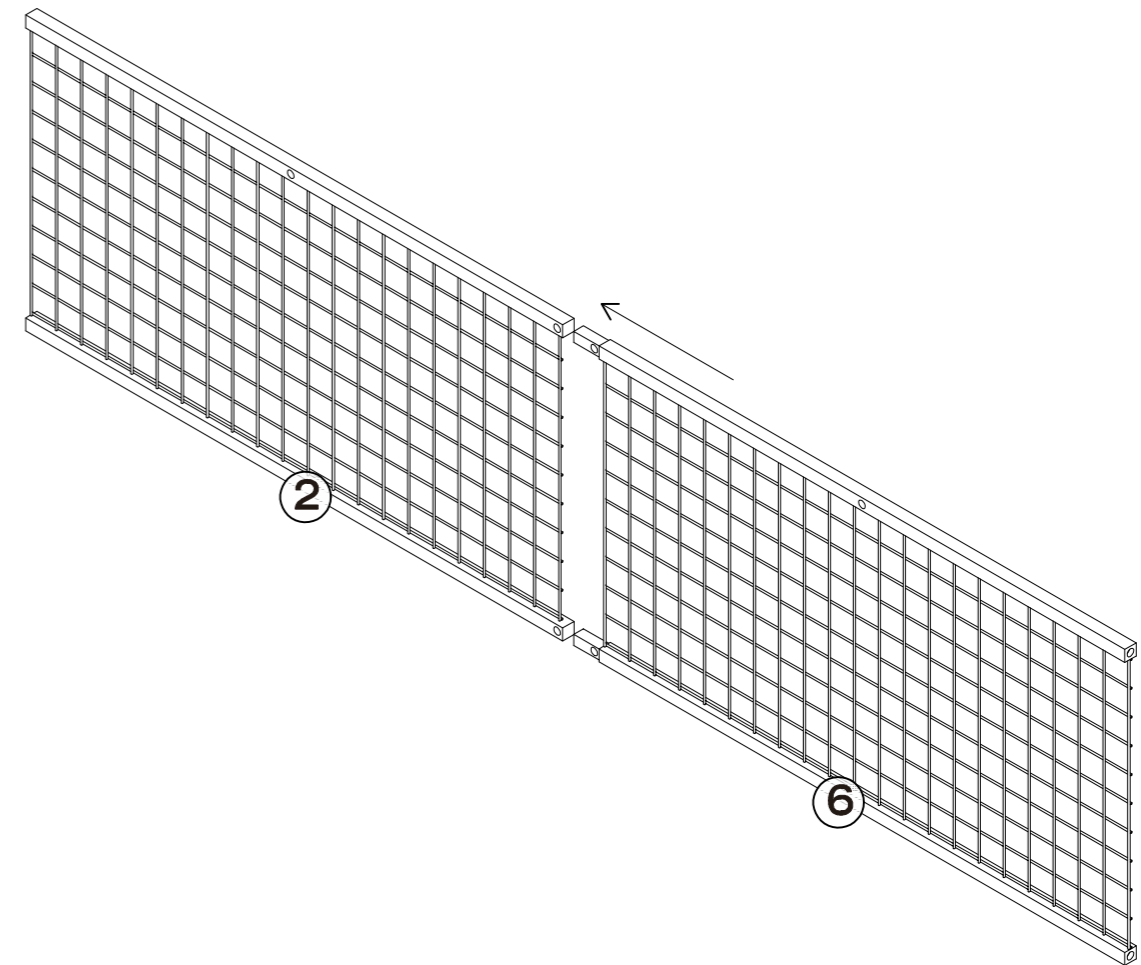
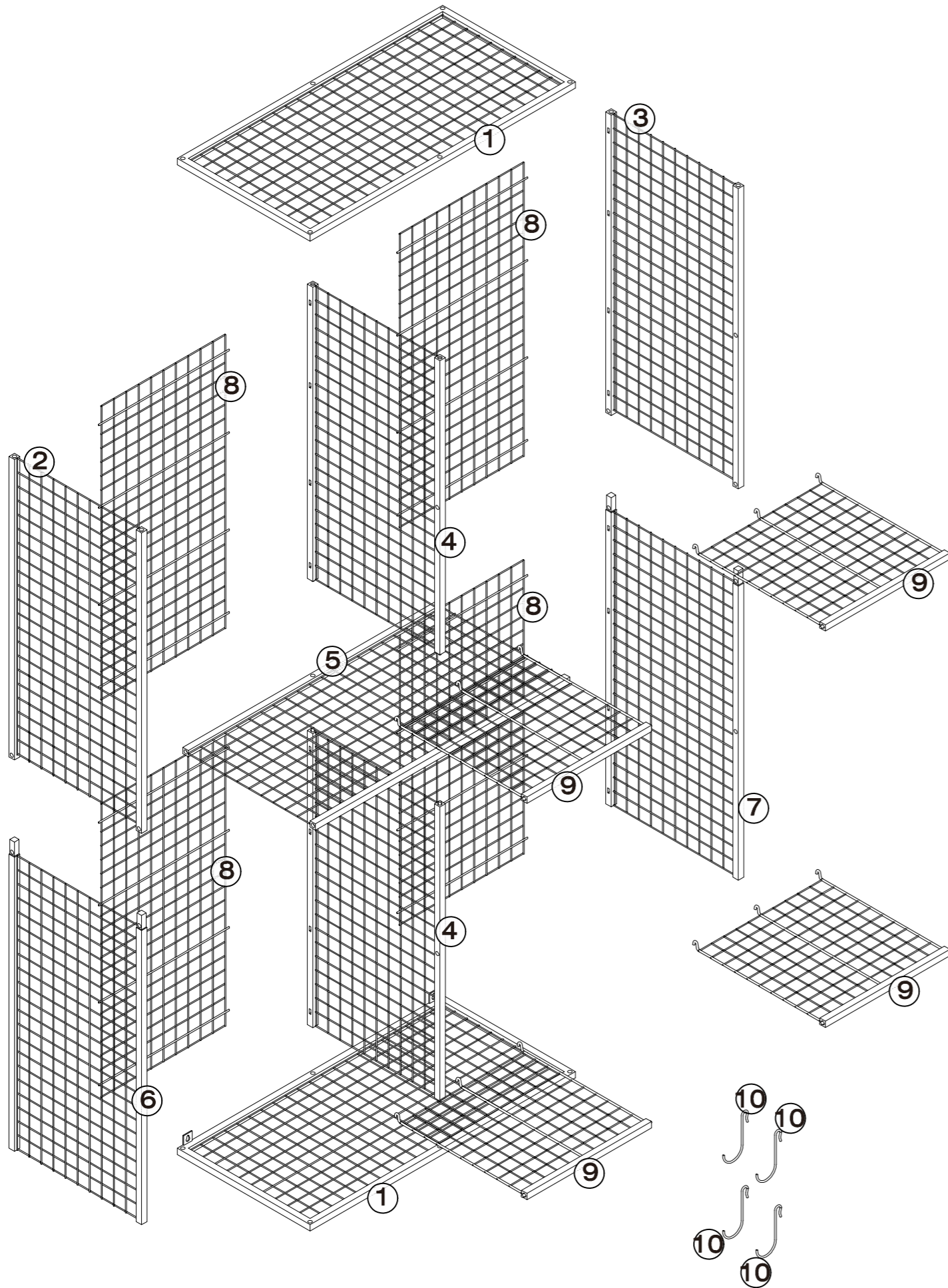

# ASSEMBLY INSTRUCTIONS

## STEP 2

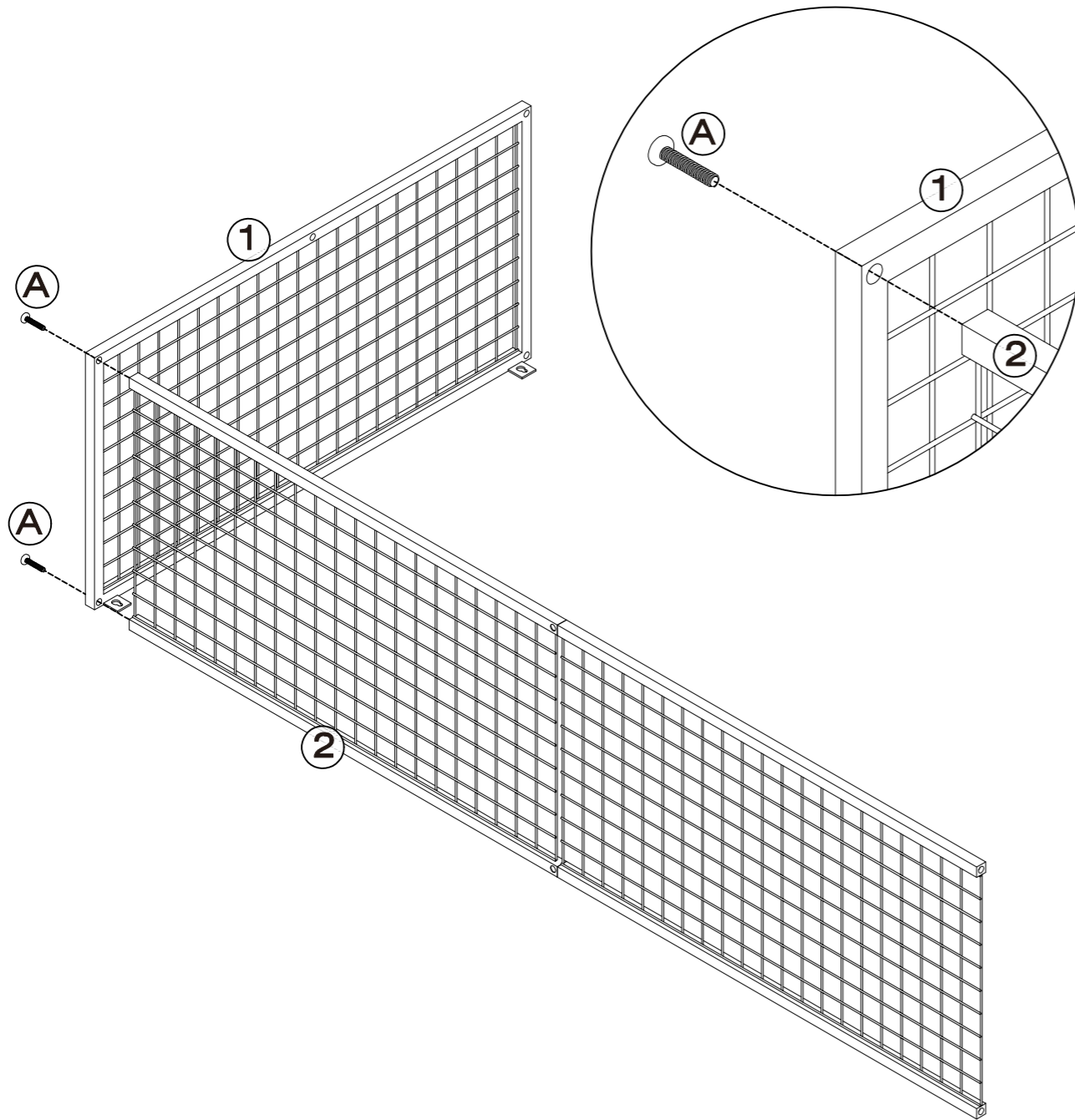

## STEP 3

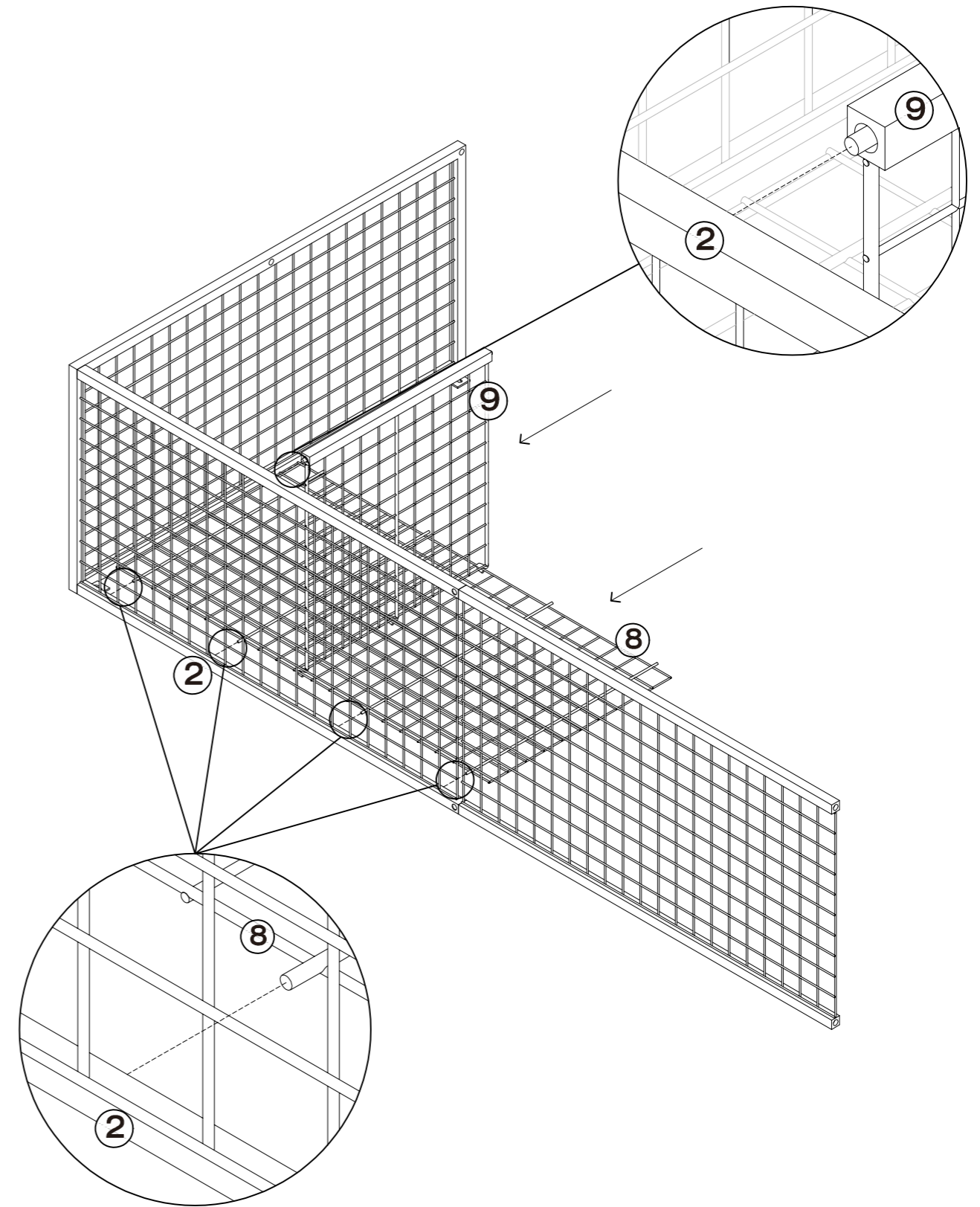

# ASSEMBLY INSTRUCTIONS

## STEP 4

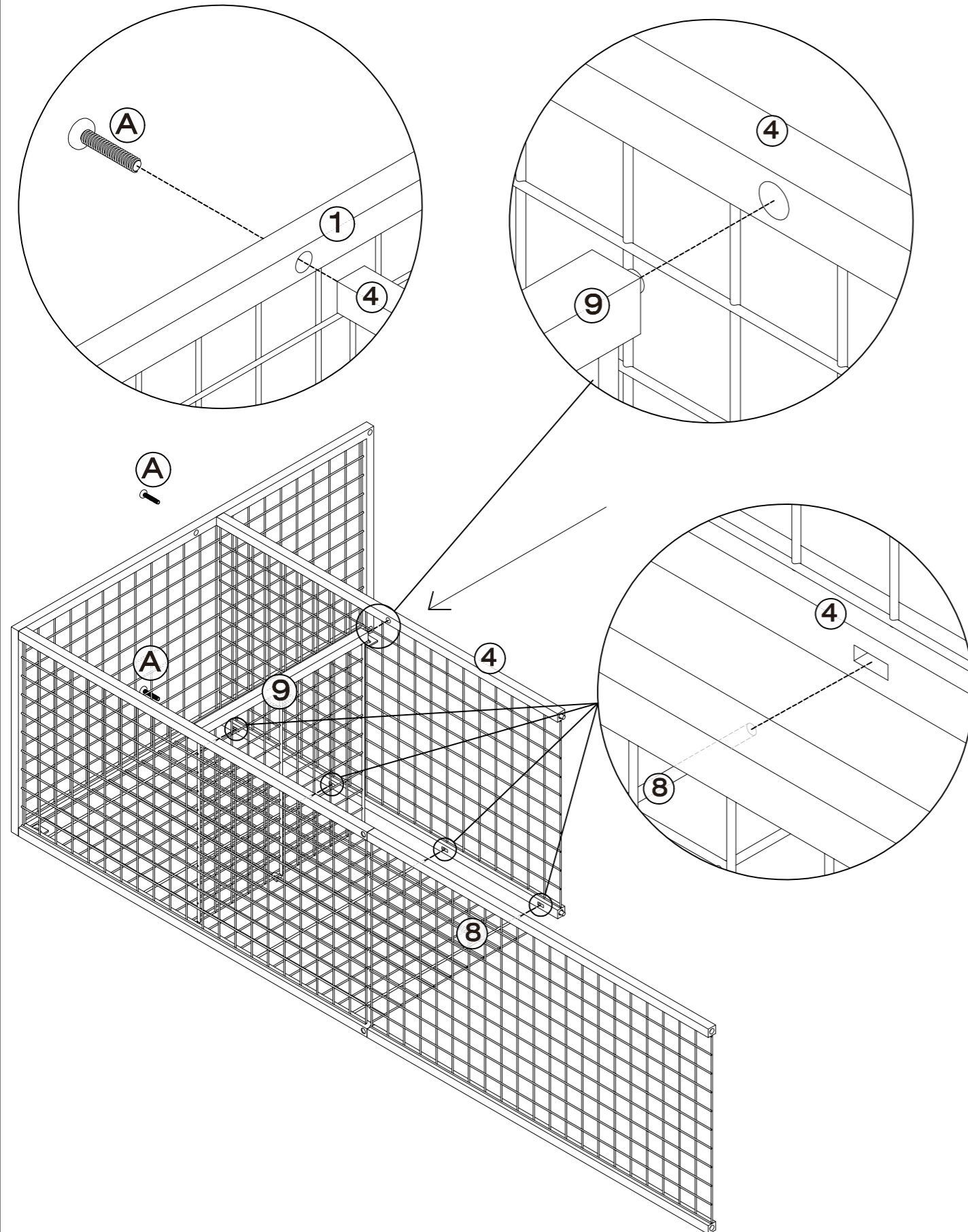

## STEP 5

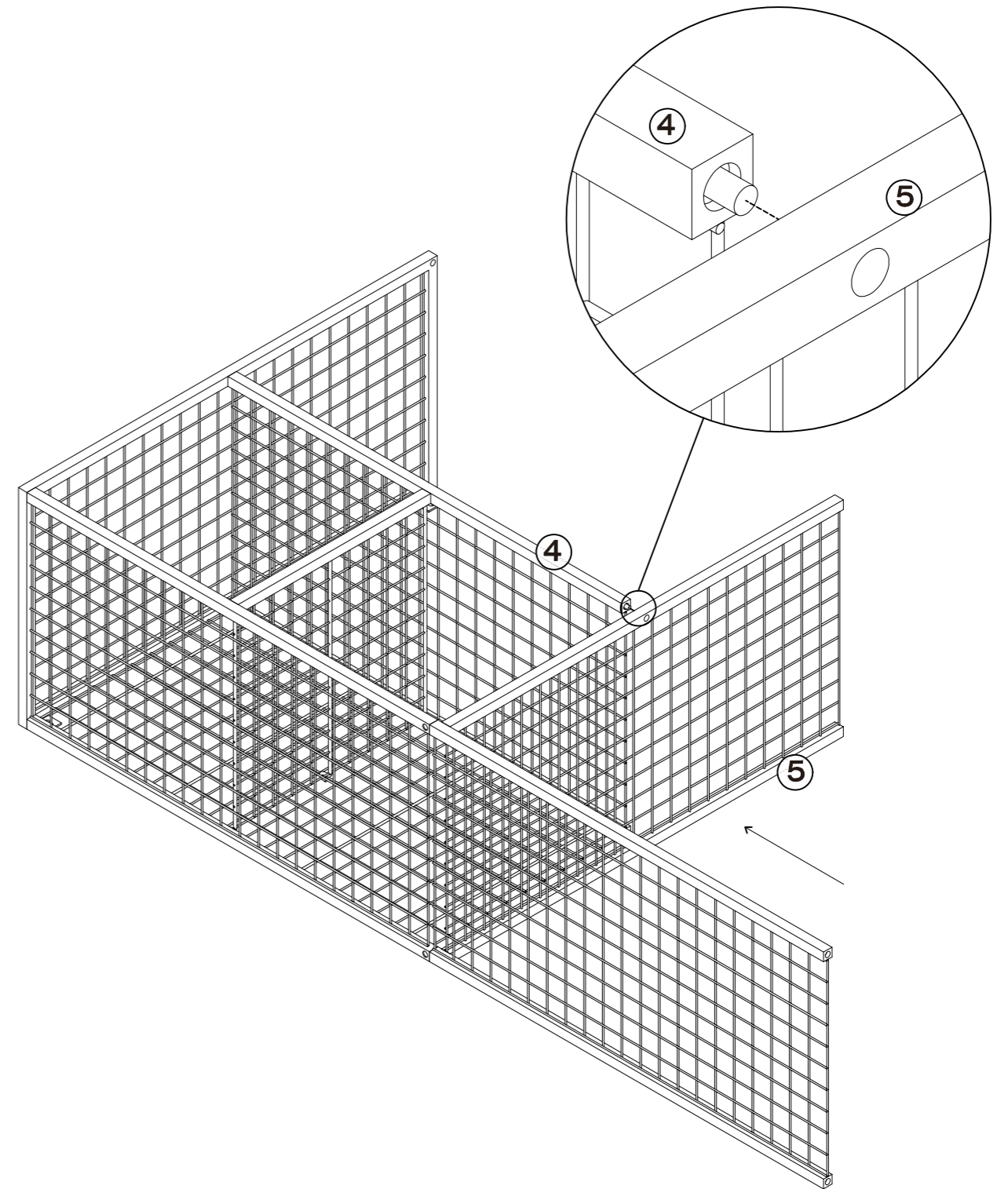

# ASSEMBLY INSTRUCTIONS

## STEP 6

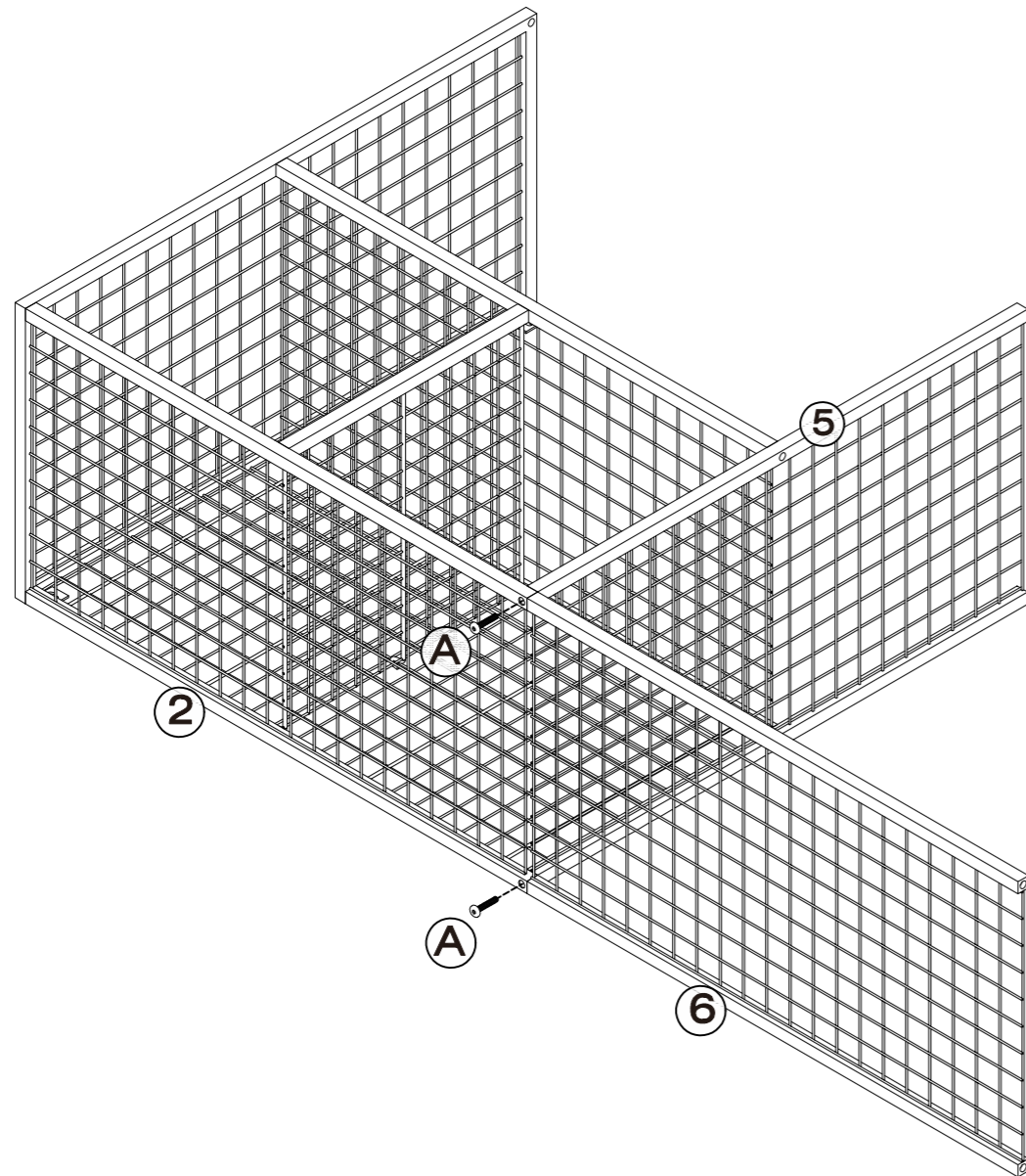

## STEP 7

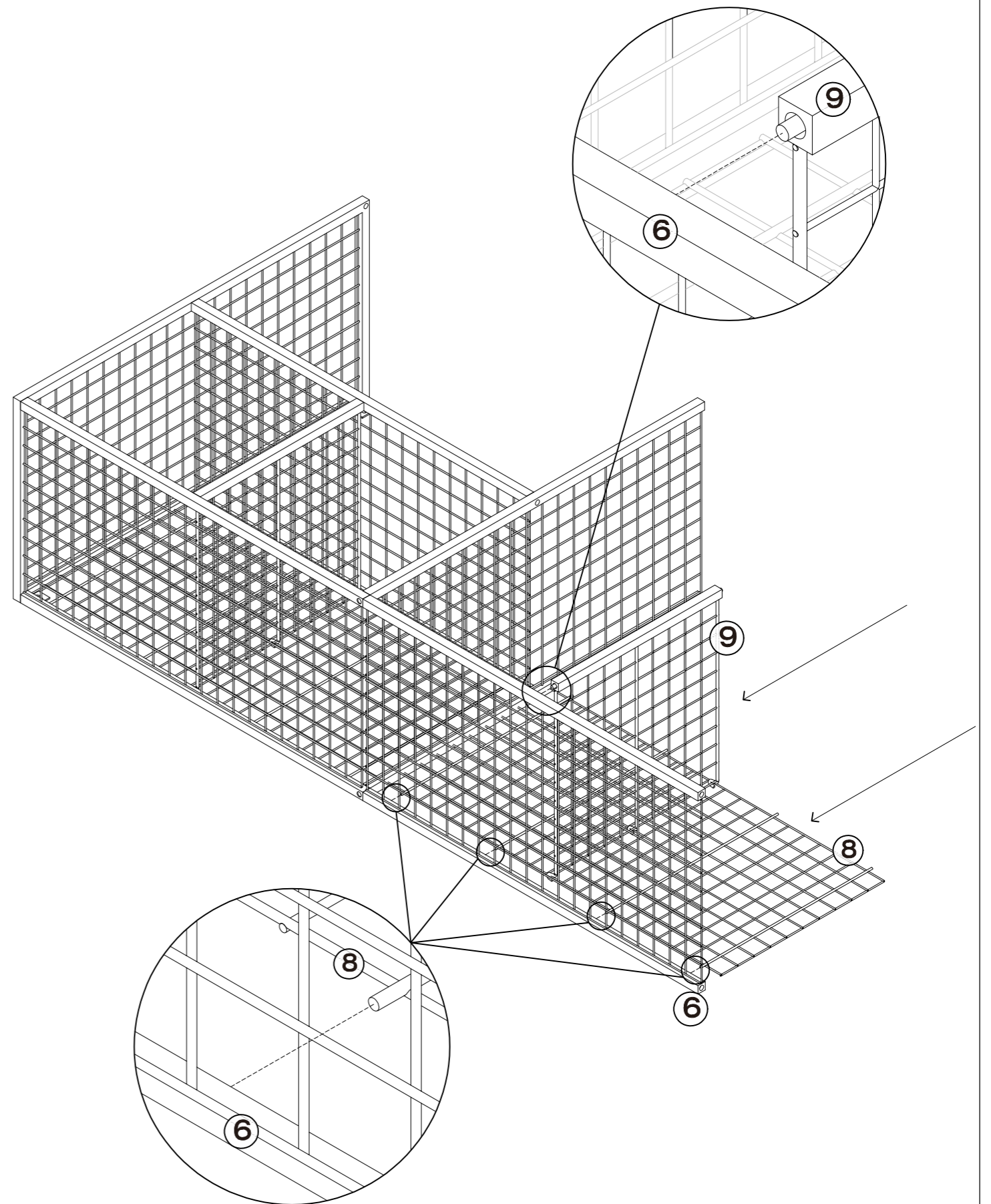

# ASSEMBLY INSTRUCTIONS

## STEP 8

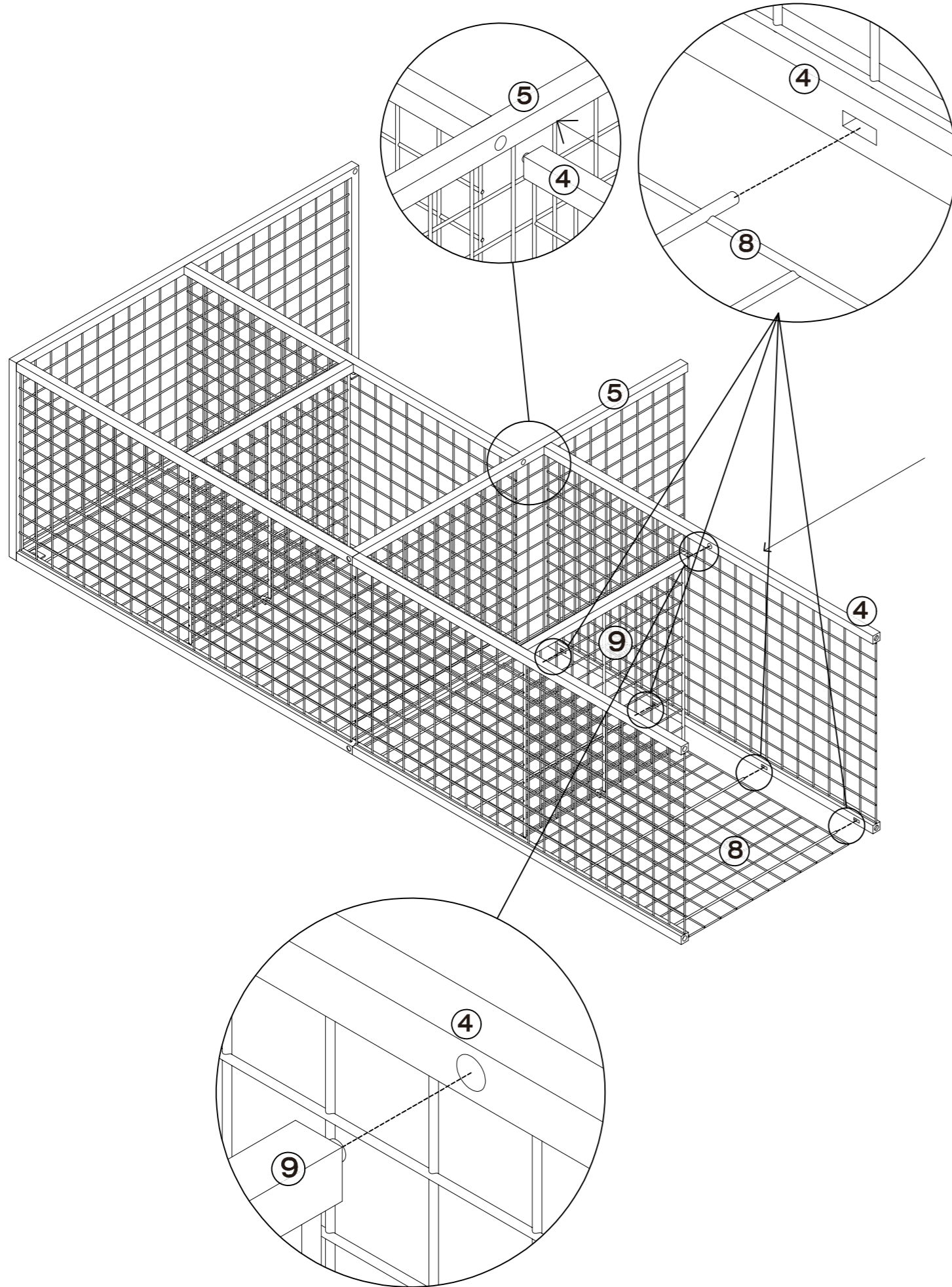

## STEP 9

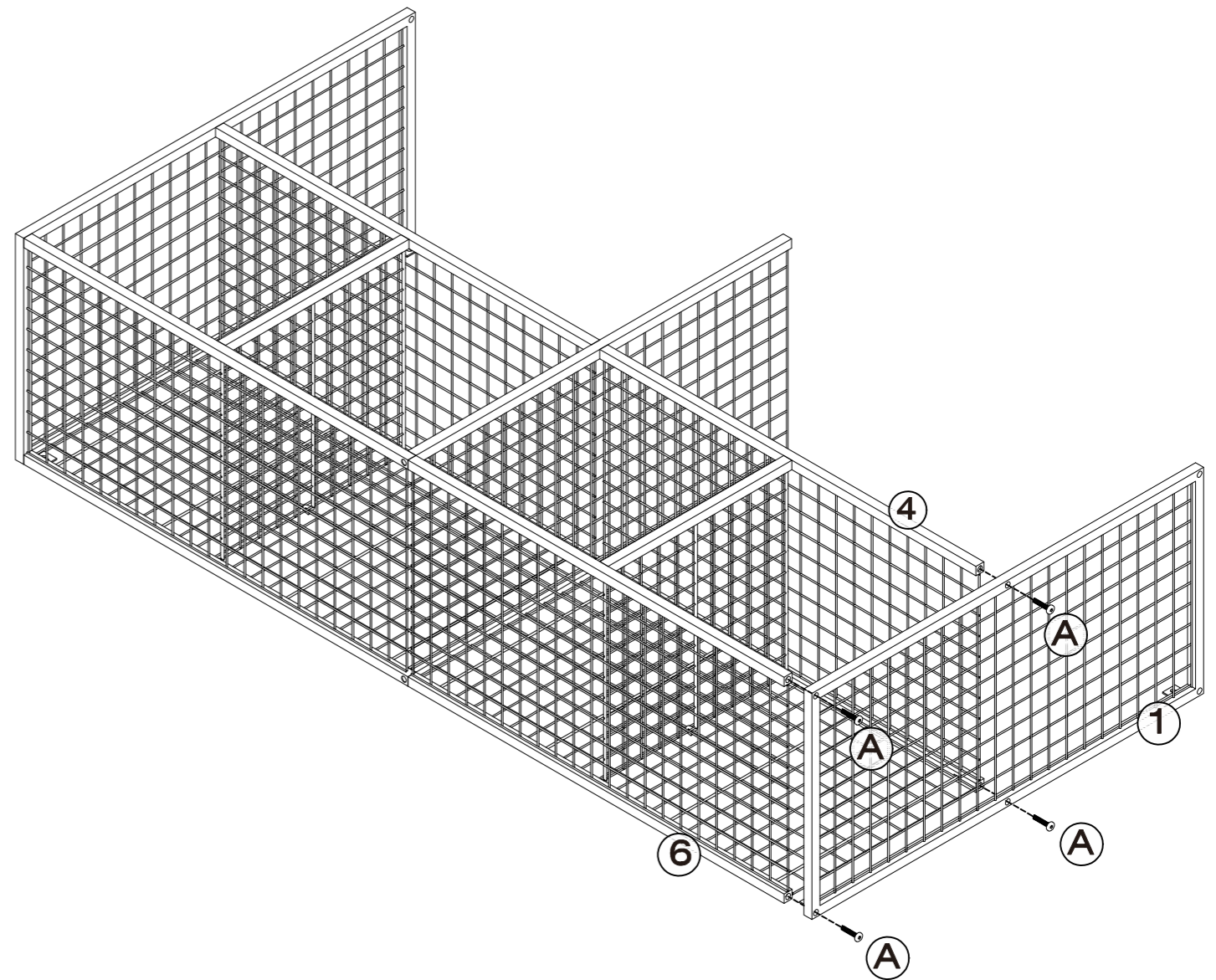
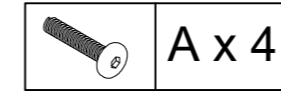

# ASSEMBLY INSTRUCTIONS

## STEP 10

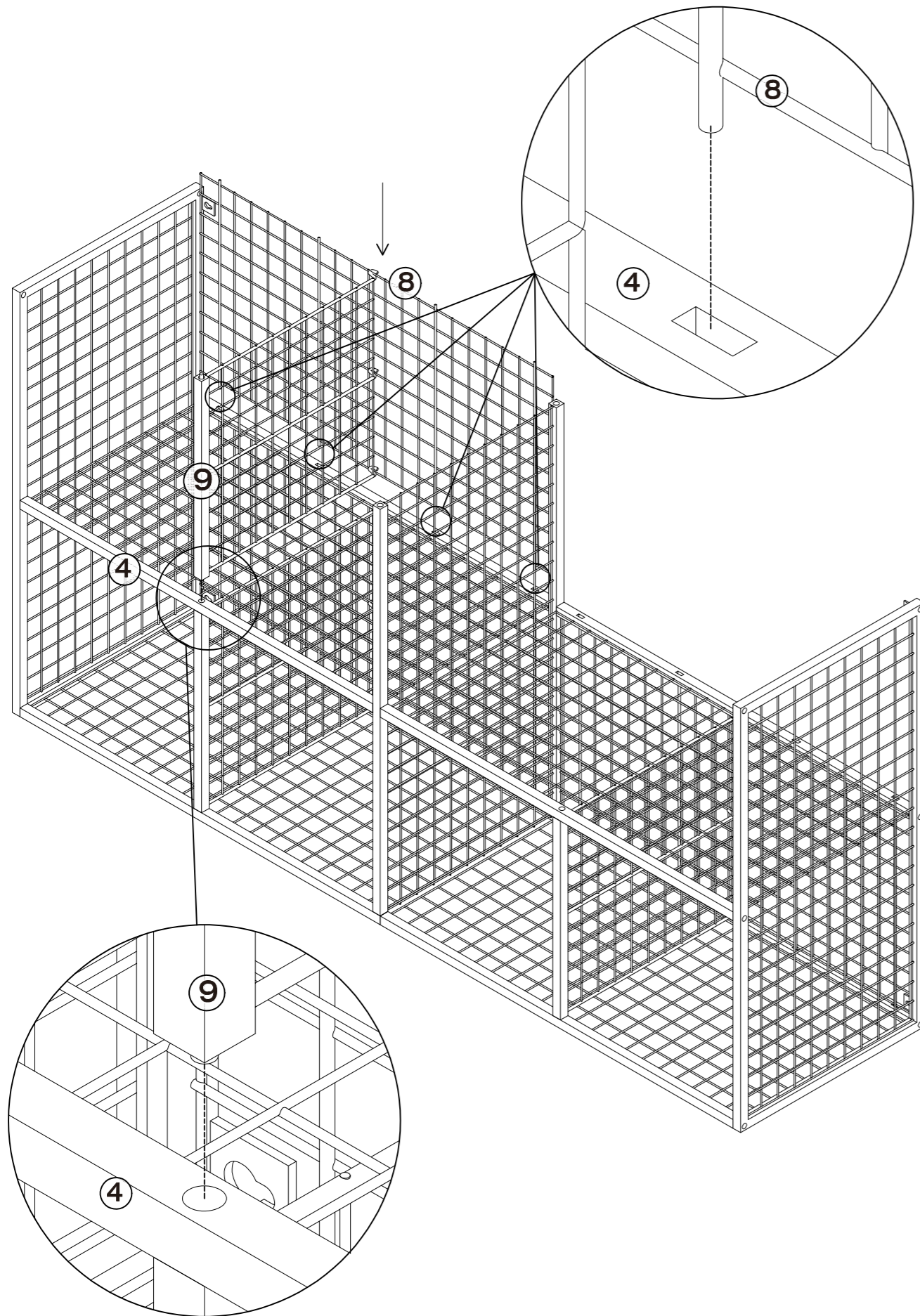

## STEP 11

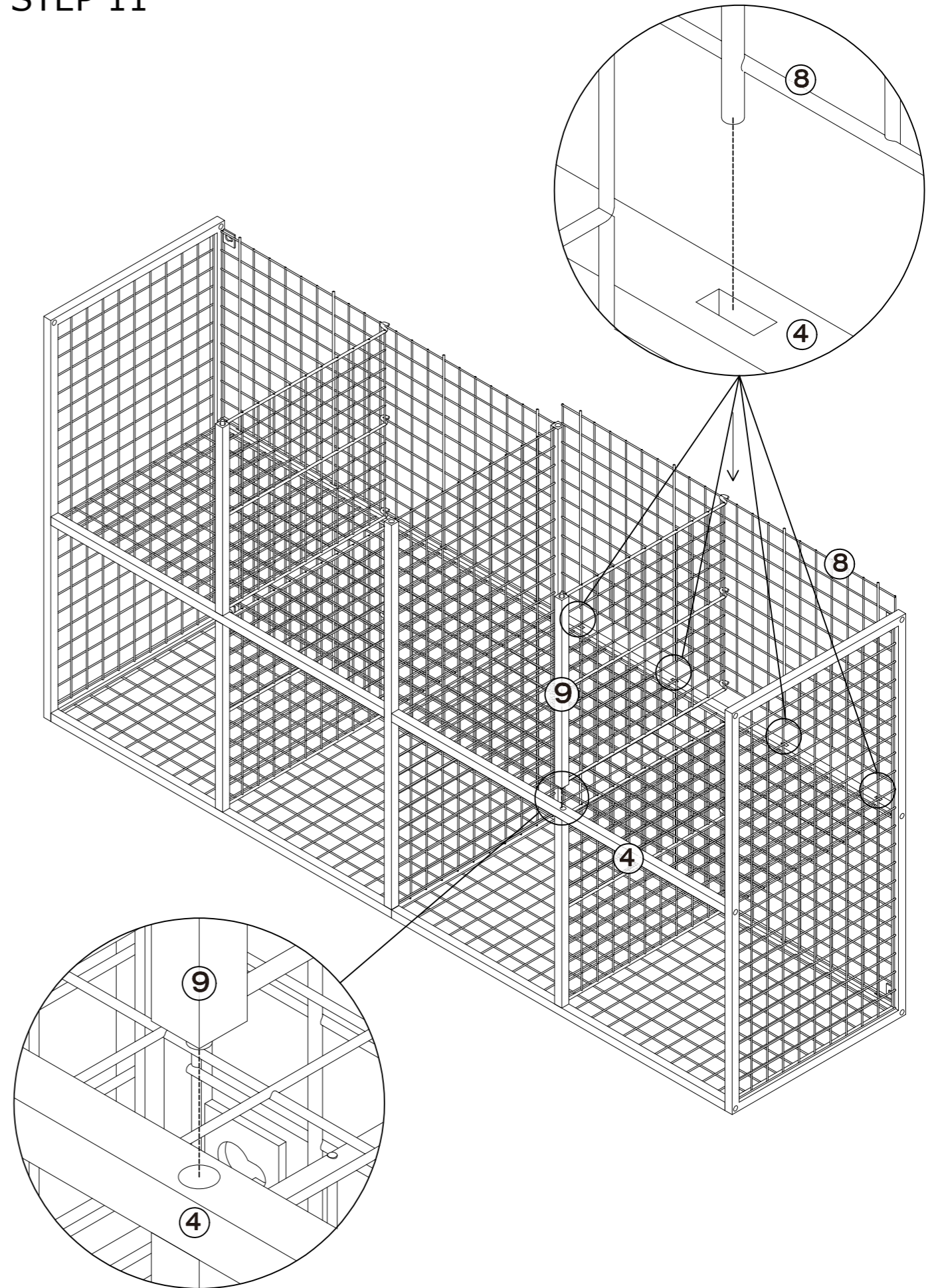

# ASSEMBLY INSTRUCTIONS

## STEP 12

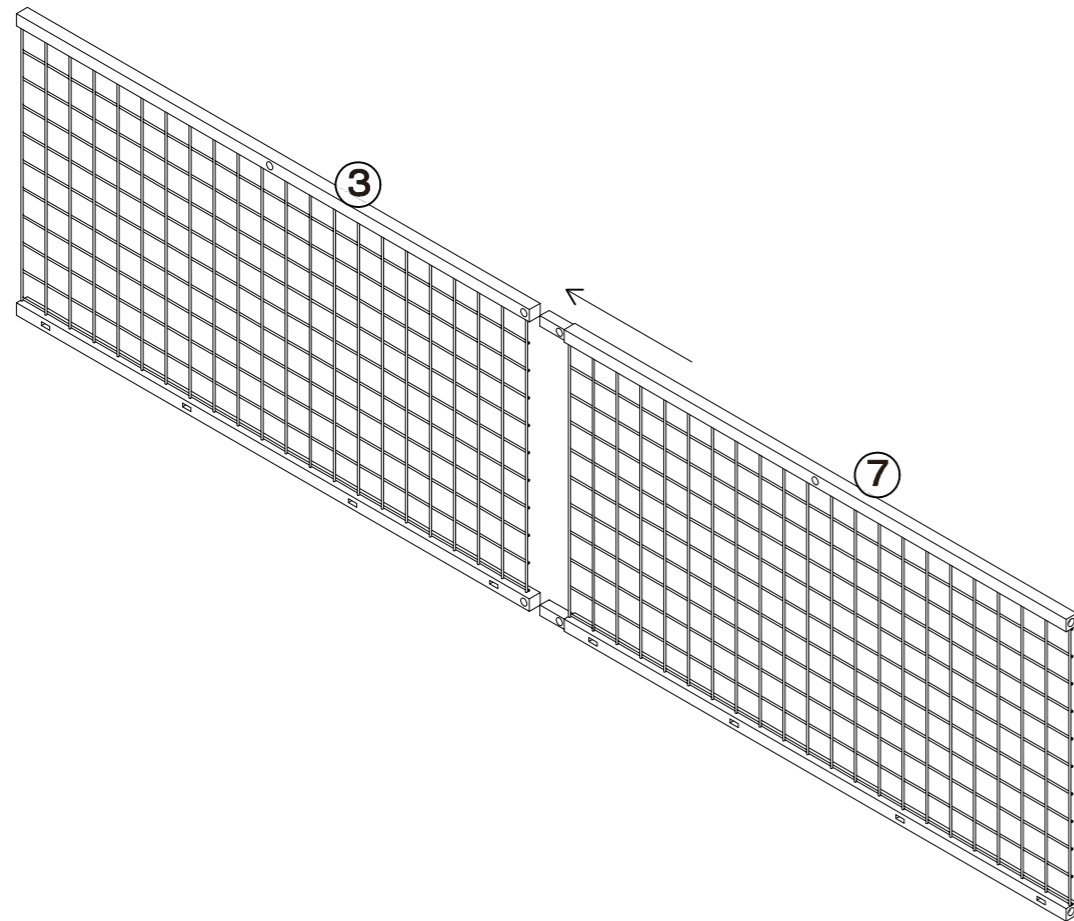

## STEP 13

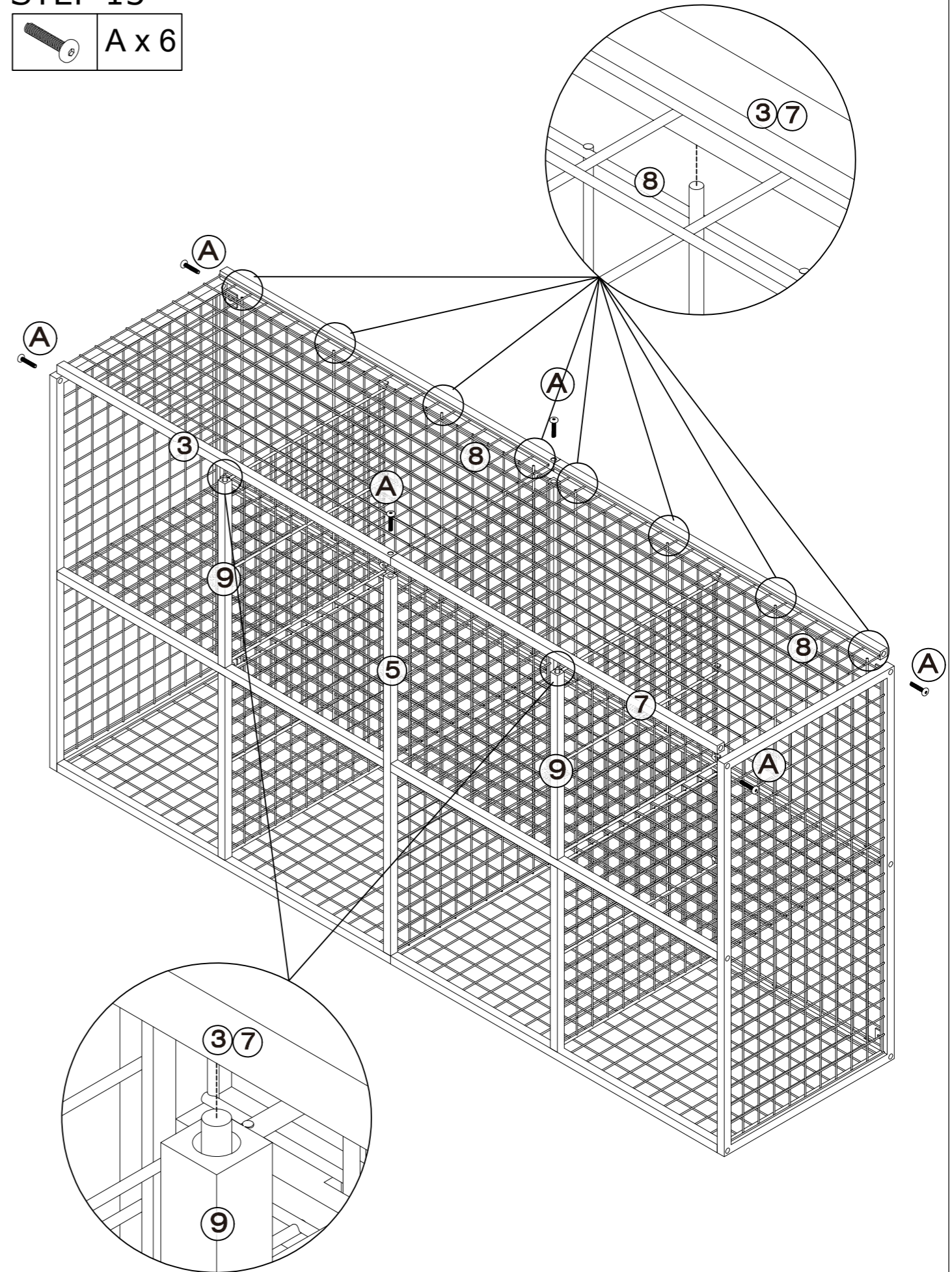
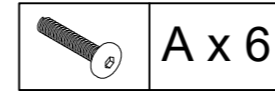

# ASSEMBLY INSTRUCTIONS

## STEP 14

Need to draw points with a pencil before drilling holes

6mm(1/4")

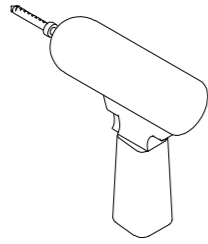

Drill with a 6mm(1/4")  
bit electric drill

## STEP 15

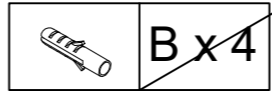

# ASSEMBLY INSTRUCTIONS

STEP 16

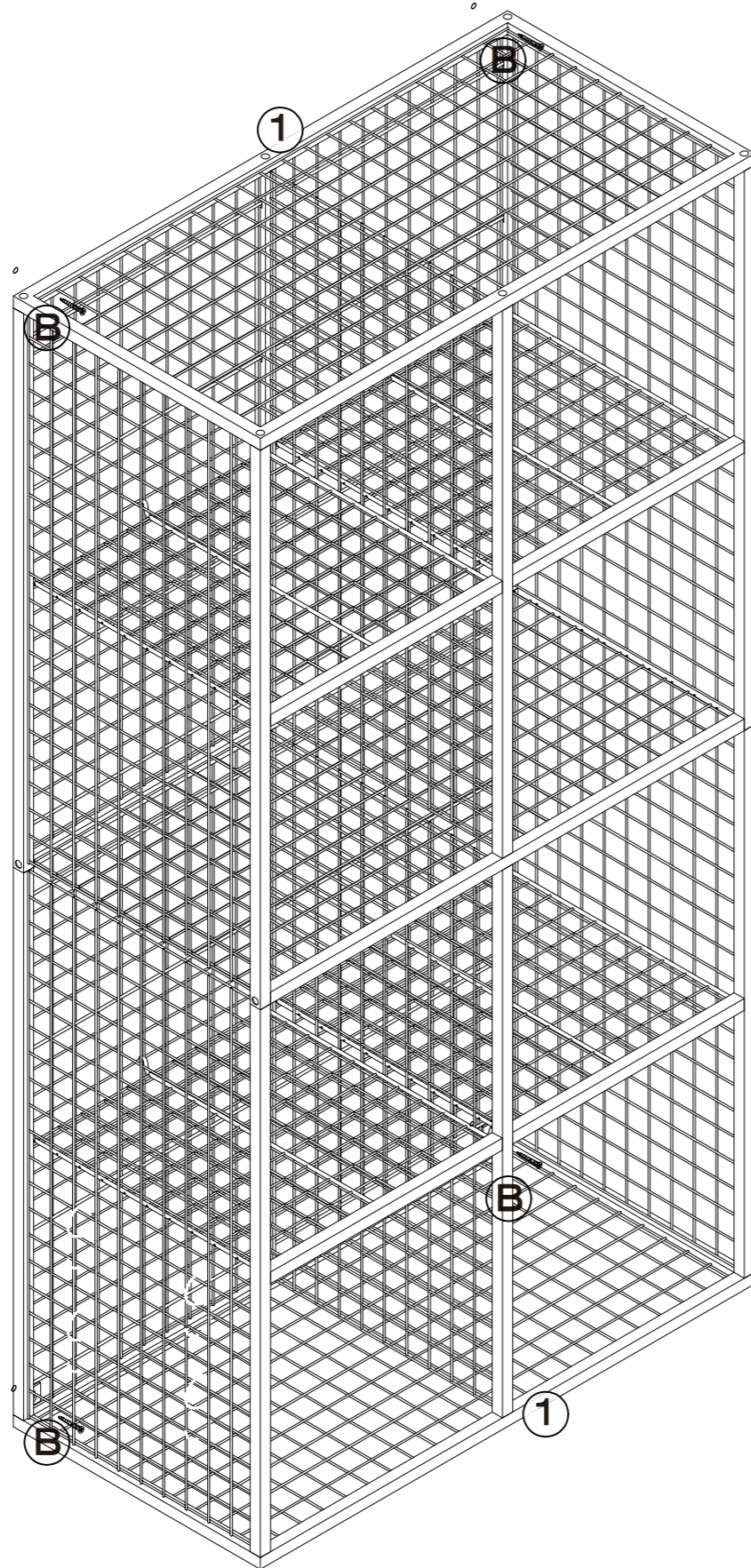

STEP 17

