

W 5W
 LED
 Im 500 Lumen
 t 20.000h
 T_k 3000K
 15000x
 <0.5s

230V~ 50Hz
 LED 3xLED-Board max.5W

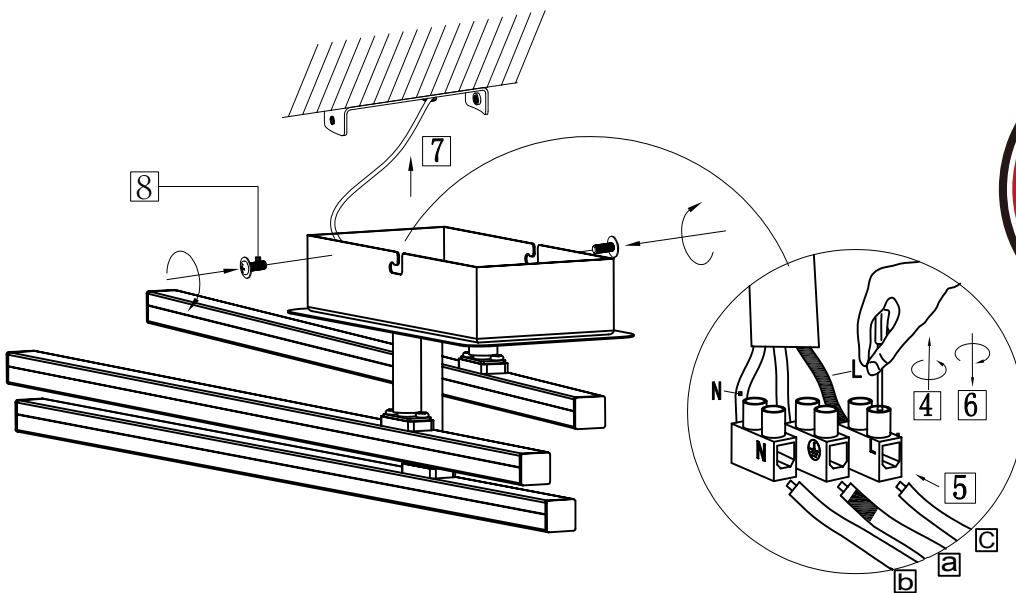
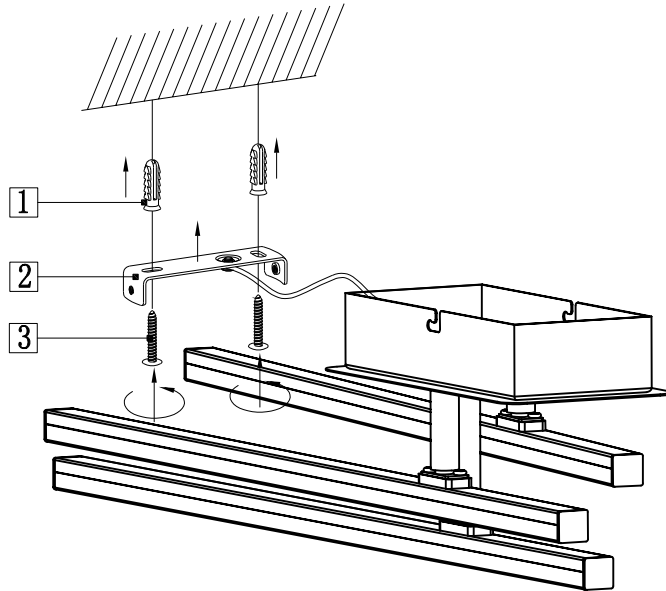

Bitte geben Sie bei technischen Fragen die Chargennummer (xxxx-xx-xx-xxxx-xxxx) an. Diese finden Sie auf dem Typenschild.

Please let us know the batch number (xxxx-xx-xx-xxxx-xxxx) for any technical questions. This can be found on the rating plate.

Lors de demande d'assistance technique, veuillez indiquer le numéro du lot (xxxx-xx-xx-xxxx-xxxx). Celui-ci se trouve sur la plaque d'identification.

