

PLUS Towel Hook

with Support Rail

Technical Data Sheet

Product Specification

The product shall be a combination towel hook and grab rail. The product shall have flange covers that conceal the mounting hardware. All components of the product shall be constructed of #304 stainless steel, suitable for use in wet environments. The grab rail portion of the product shall be 1.25" / 3.2cm in diameter. The product shall have a weight capacity of 500lbs / 227kg. Product shall comply with ADA Guidelines, specifying the structural strength of grab bars, tubs and shower seats. The grab rail shall be HealthCraft model PLUS-TH-____ (see table below for appropriate product code).

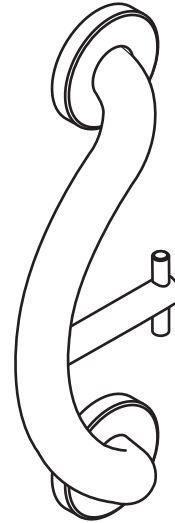

Key Features

- 2-in-1 Bathroom Accessory with with Integrated Support
- Solid Construction and Mounting
- Suitable For Use in a Wet Environment
- 500lbs / 227kg Weight Capacity *ADA Compliant

Codes and Standards

- ADA 609.2 Cross Section
- ADA 609.3 Spacing
- ADA 609.8 Structural Strength



Specified Model

Model	Finish	Material
PLUS-TH-BLK	Matte Black	#304 Stainless Steel
PLUS-TH-BS	Brushed	
PLUS-TH-CP	Polished Chrome	

PLUS Towel Hook

with Support Rail

Technical Data Sheet

Product Dimensions

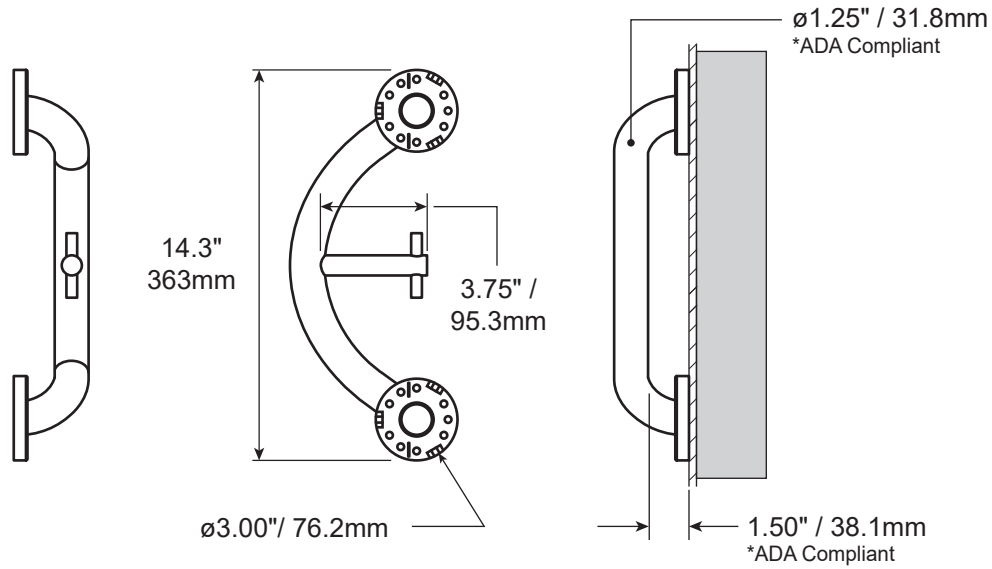

Shipping Dimensions

Model	Height (H)	Width (W)	Depth (D)	Weight
TH	3.15" / 8.0cm	15.2" / 38.5cm	7.28" / 18.5cm	1.20lbs / 0.54kg

