

Installation and User Instructions

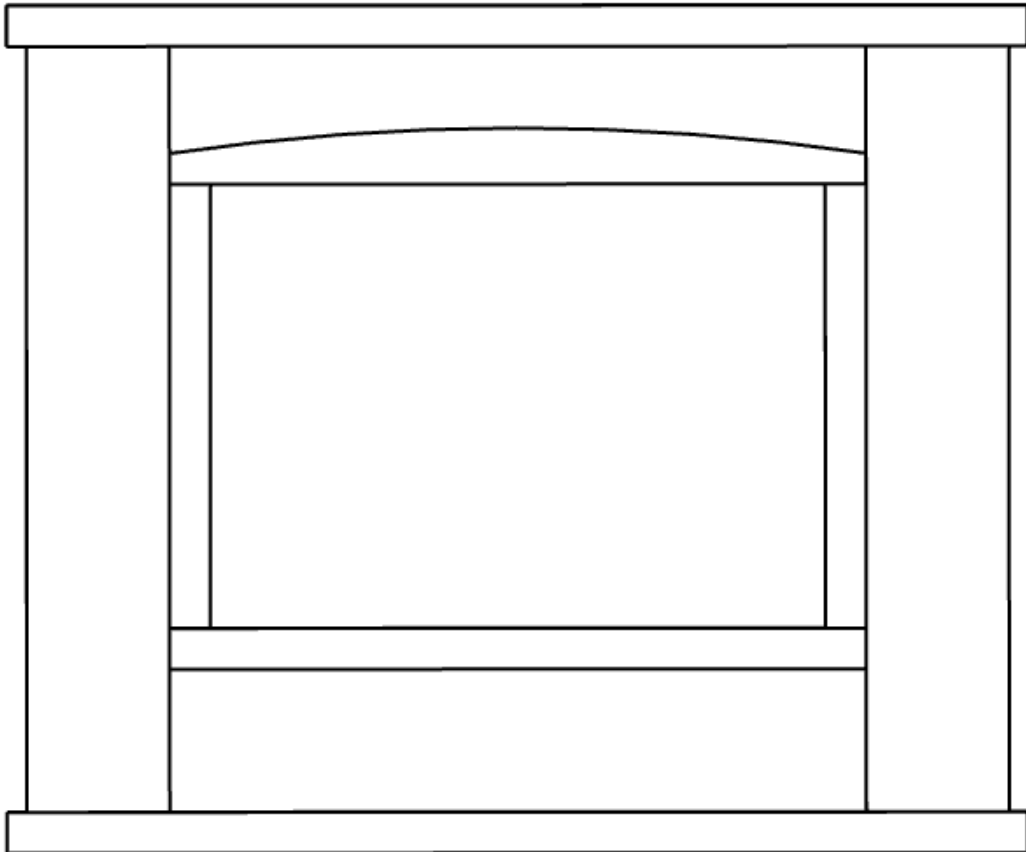

**PLEASE READ THIS MANUAL BEFORE INSTALLING AND USING APPLIANCE.
INSTALLER: DO NOT DISCARD THIS MANUAL – LEAVE WITH THE CUSTOMER
SAVE THESE INSTRUCTIONS FOR FUTURE REFERENCE.**

Contents

Seccion 1 Dimensiones	3
Section 2 Assembly and installation	3
Section 3 Cleaning & maintenance.....	10



Contenido

Seccion 1 Dimensiones	11
Seccion 2 Montaje y instalacion.....	11
Sección 3 Limpieza & mantenimiento.....	18



SECTION 1 DIMENTIONS.....	19
Section 2 Assemblage et installation	19
Section 3 Nettoyage et entretien	26

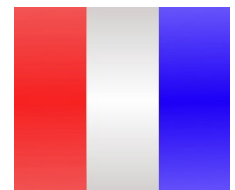

SECTION 1 DIMENSIONS

Dimensions in mm

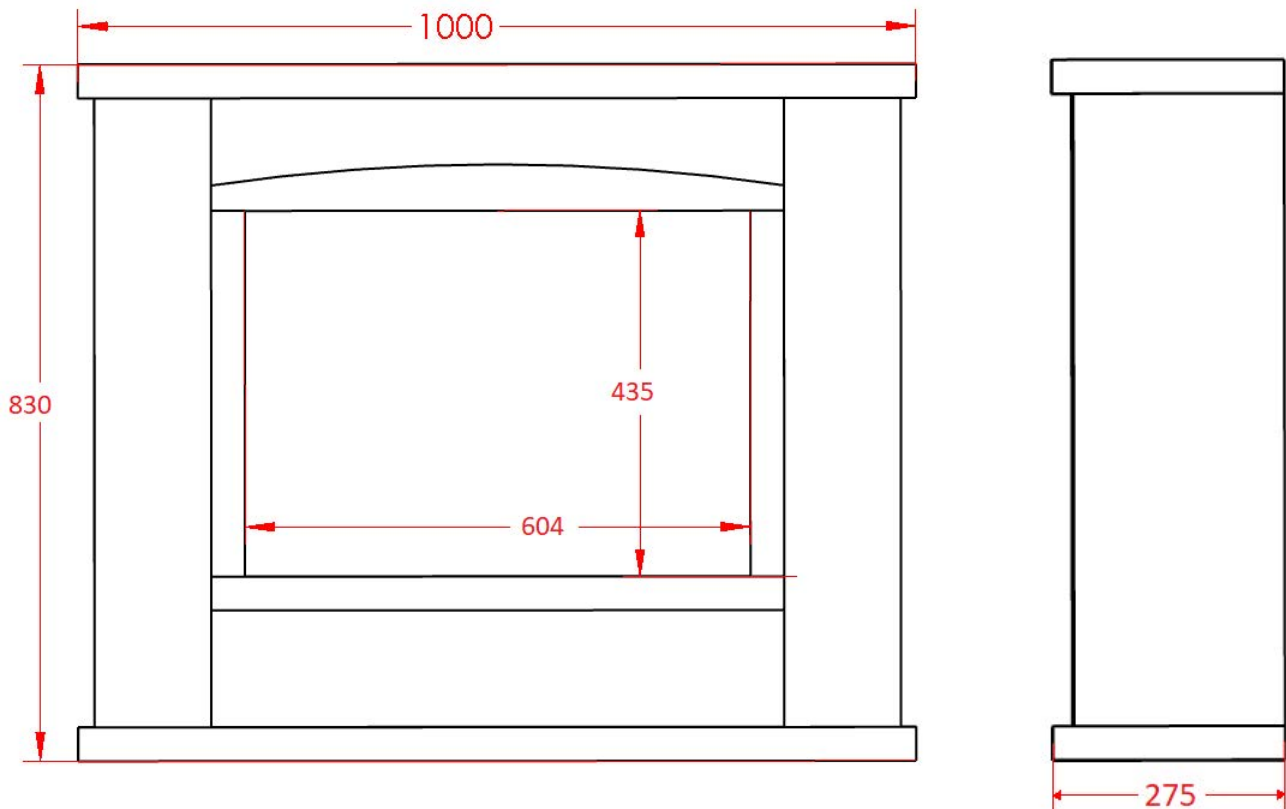



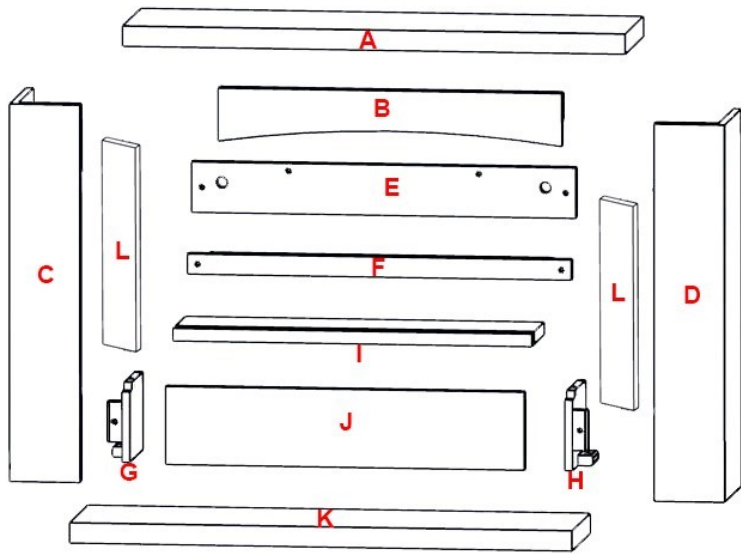

SECTION 2 ASSEMBLY AND INSTALLATION

2.1 Unpack

- Open the package carefully and remove all pieces. Carefully inspect each part for any damage before you begin assembly.
- Make sure that you have all the parts listed below before assembling.
- Retain packaging for future transport and/or storage.



No.	Name	Quantity
A	Top panel	1
B	Curved LED panel	1
C	Left hand leg	1
D	Right hand leg	1
E	Second top panel	1
F	Second bottom panel	1
G	Left hand side panel	1
H	Right hand side panel	1
I	Top shelf panel	1
J	Back shelf panel	1
K	Base panel	1
L	Second leg panel	2
M	Cam and pin fixing 	15+3 spare
N	Wood dowel 	14+3 spare
O	Screw M6X30mm 	14+3 spare
P	Washer 	14+3 spare
Q	LED extension lead - 460mm	1

NOTE: left and right of product are distinguished by its front view.

2.2 Before installation

Tools required: Magnetic Phillips screwdriver



2.3 Installation

NOTE!

- Assembly required by two adults.
- This fireplace suite must be fitted to the wall. Mirror plates are supplied with the mantel, but any other suitable concealed fixing may be used. **Do not use any silicon-based sealant.**
- To avoid over tightening, **do not use** an electric screwdriver.
- Use washers when fixing with screws. **Do not** over tighten bolts.
- Only use the screws supplied with this mantel.
- To avoid scratching the mantel, the fire must be inserted from the rear.

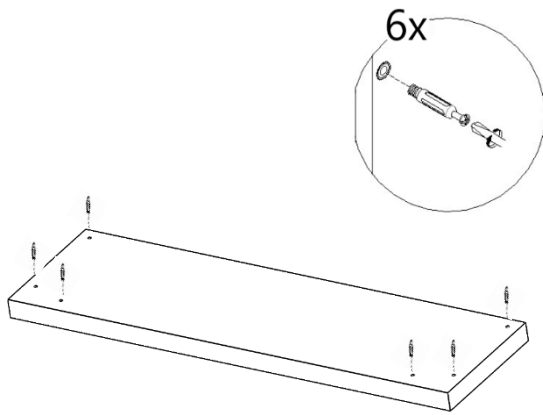

1. Using the screwdriver, insert 6x cam pins into base panel (K) as shown.

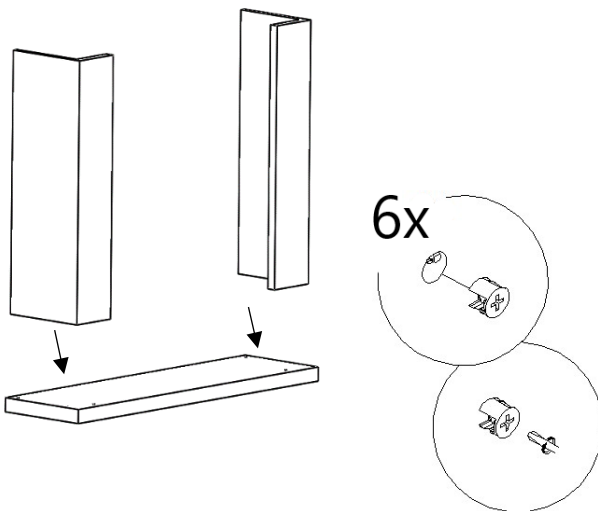

2. Slide both right hand leg (C) and left hand leg (D) onto the base panel (A), Insert the cams and tighten up.

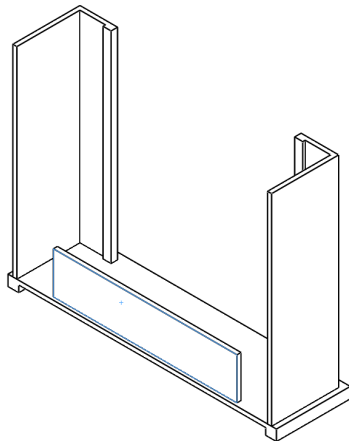

3. Fix the back shelf panel (J) with 7 wooden dowels.

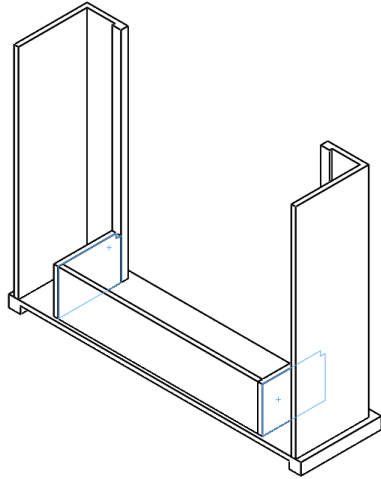

4. Fix the left and right side panel (G&H) onto the left hand leg and right hand leg (C&D).
Use 2x M6x30 screws & washers for each side

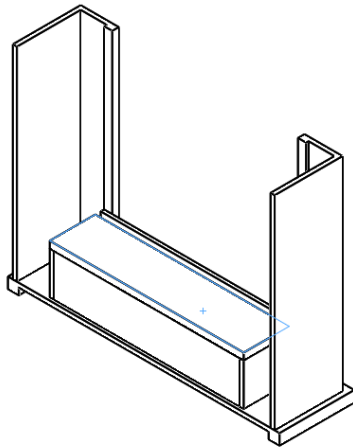

5. Fix the top shelf panel (I) with 7 wooden dowels

Note: please ensure shelf LED cable is kept clear when attaching panel I

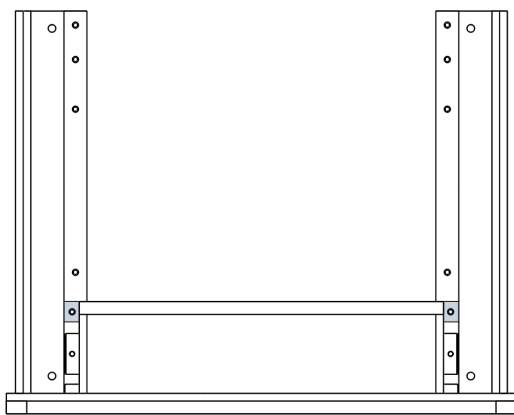

6. Attach second bottom panel (F) to both legs (C & D) with 2 M6x30 screws and washers

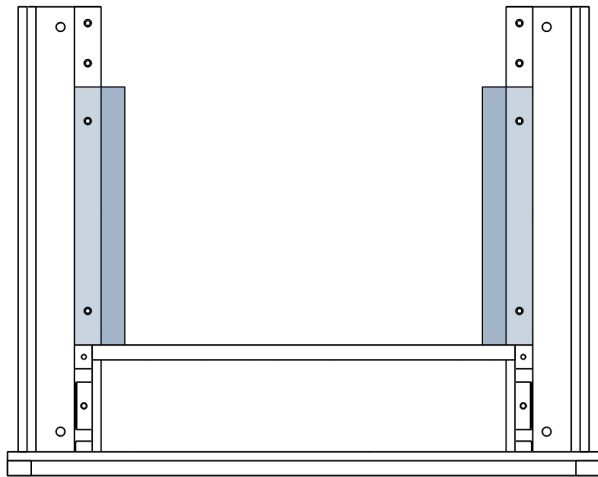

- Attach second leg panels (L) to both legs (C & D) using 4x M6x30 screws and washers

Note: 2 screws and washers are used for each side.

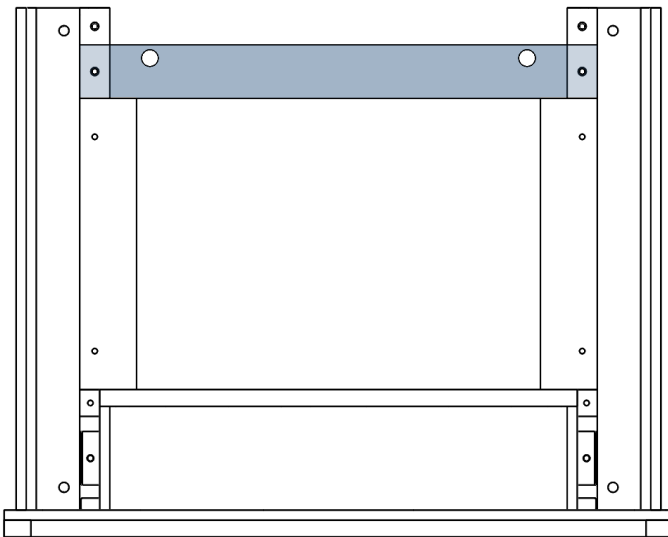

- Attach second top panel (E) to both legs (C & D) with 2 M6x30 screws and washers

front of mood lighting

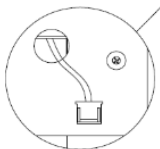
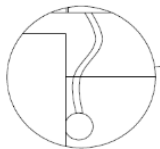

rear of mood lighting

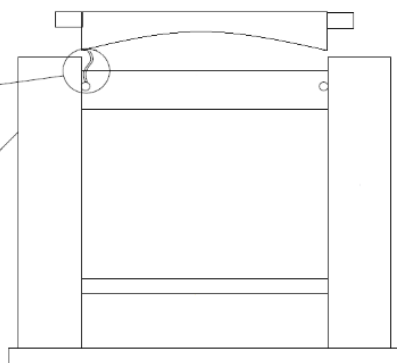

- Feed the socket and wire of the mood lighting through the hole on the left side panel (C) before fixing the front top panel (B). Check that the LED strip is still pushed firmly down into position on the self-adhesive pads.

When attaching the front top panel (B) use 2 M6x30 screws and washers and attach to right hand side leg and left hand side leg (C & D)

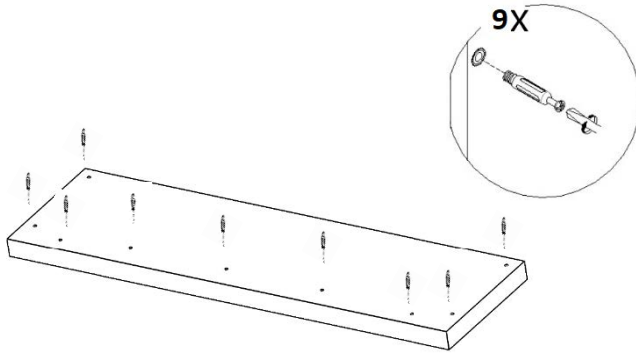

10. Using the screwdriver, insert 9x cam pins into top panel (A) as shown.

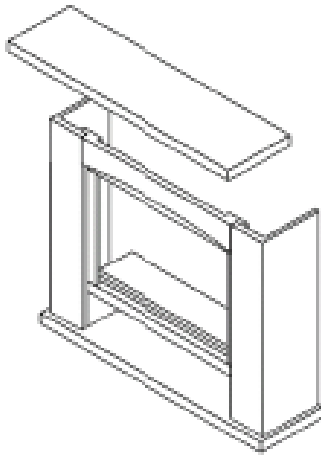

11. Attach the top panel (A) to the assembly and tighten the cams from the rear of the mantel

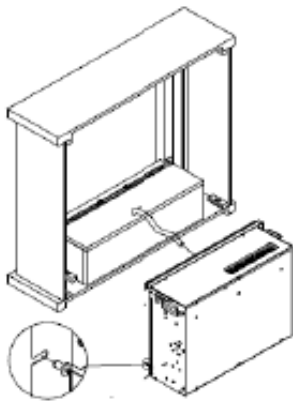

12. Install the fire from back of the mantel and use 4 screws to fix firmly. (Screws are supplied together with the fire).

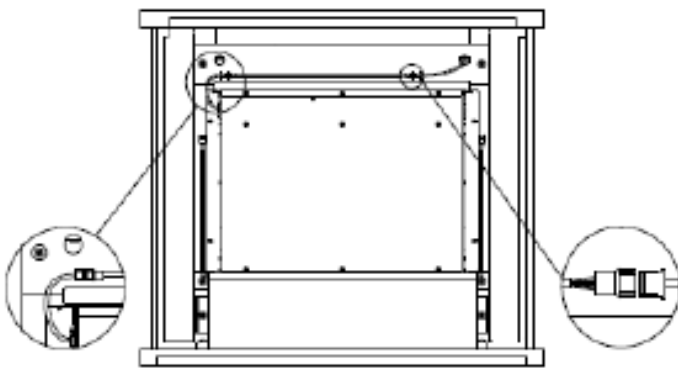

13. (A)) If you wish to only use the lower moodlight, connect the wires as shown in the picture. Connect the wires with the extension lead 600mm (Q) to the fire as shown in the picture.

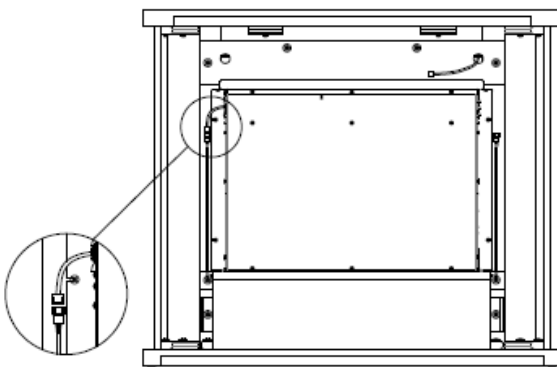

(B) If you wish to only use the lower moodlight, connect the wires as shown in the picture.

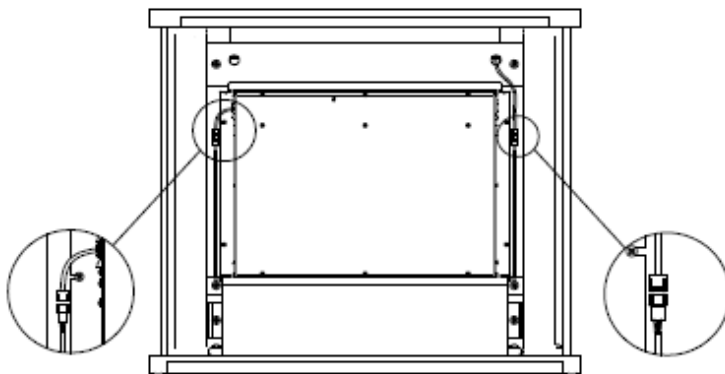

(C) If you wish to use both moodlights at the same time, connect the wires as shown in the picture.

SECTION 3 CLEANING & MAINTENANCE

Your mantel surface coating will give off a slight odour for a brief initial period. Try to ventilate as much as possible during this time.

Daily cleaning:

- Clean the mantel surfaces with a soft, lint-free cloth.
- Do not use cleaning or polishing products

Avoid

- Long-term direct sunlight.
- Excessive temperatures and humidity to protect the life of your furniture surface
- Do not put heavy or sharp objects on this mantel

SECCIÓN 1 DIMENSIONES

Dimensiones en mm

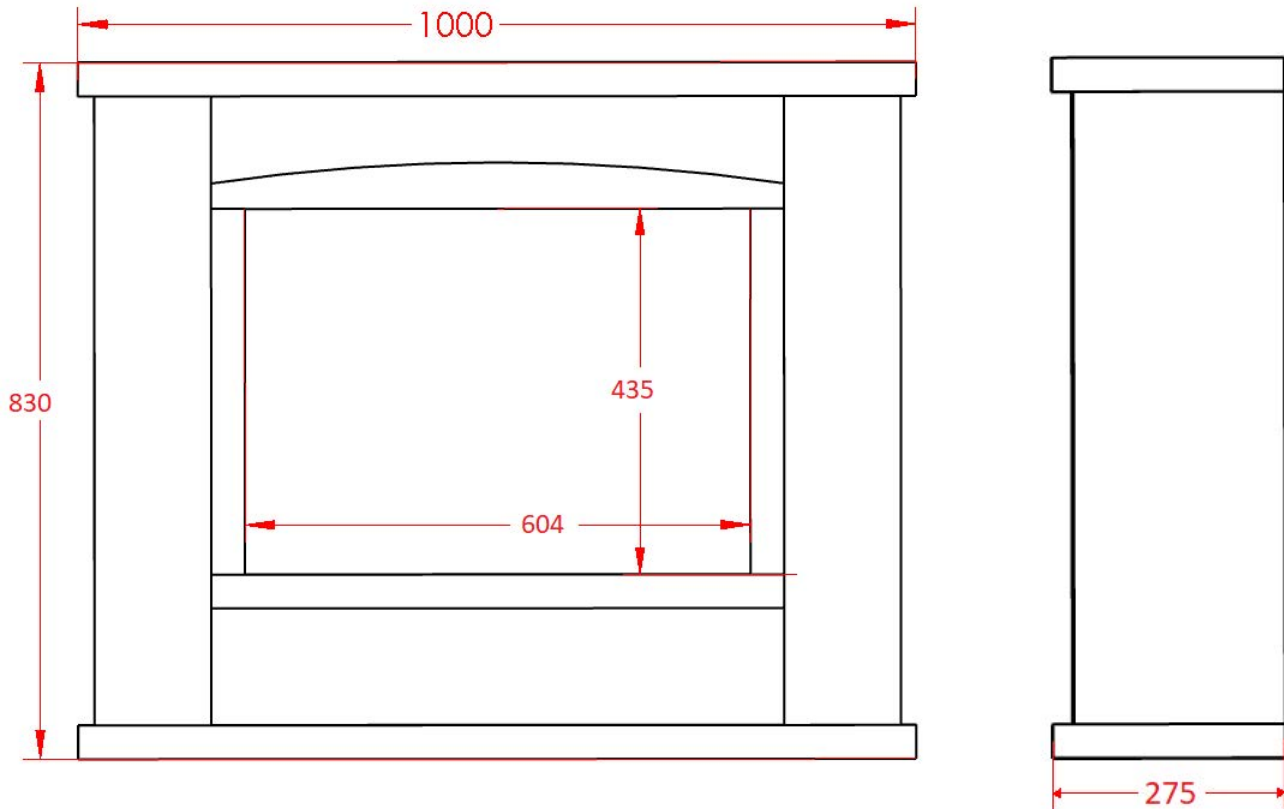



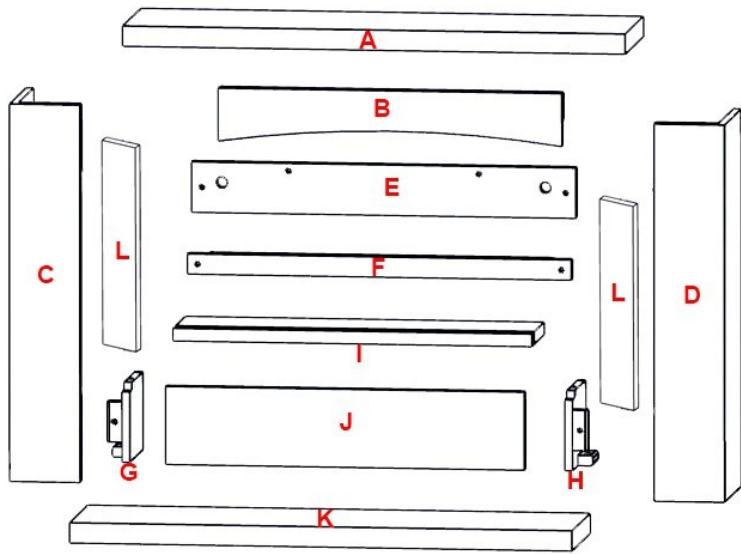

SECCIÓN 2 MONTAJE E INSTALACIÓN

2.1 Desembalar

- Abra el paquete con cuidado y retire todas las piezas. Inspeccione cuidadosamente cada pieza en busca de daños antes de comenzar el ensamblaje.
- Asegúrese de tener todas las piezas que se enumeran a continuación antes de ensamblar.
- Conserve el embalaje para su futuro transporte y / o almacenamiento.



No.	Nombre	Cantidad
A	Panel superior	1
B	Panel LED curvo	1
C	Pierna de la mano izquierda	1
D	Pierna de la mano derecha	1
E	Segundo panel superior	1
F	Segundo panel inferior	1
G	Panel lateral izquierdo	1
H	Panel lateral derecho	1
I	Panel de estante superior	1
J	Panel de estante trasero	1
K	Panel de base	1
L	Panel de segunda pierna	2
M	Tuerca y cerradura de 	15+3 Repuesto
N	Clavija de madera 	14+3 Repuesto
O	Tornillo M6X30mm 	14+3 Repuesto
P	Lavadora 	14+3 Repuesto
Q	Cable de extensión LED - 460mm	1

NOTA: la izquierda y la derecha del producto se distinguen por su vista frontal.

2.2 Antes de la instalación



Herramientas necesarias: destornillador Phillips magnético

2.3 Instalación

¡NOTA!

- Requiere montaje por dos adultos.
- Esta suite con chimenea debe instalarse en la pared. Las placas de espejo se suministran con la repisa, pero se puede utilizar cualquier otra fijación oculta adecuada. No utilice ningún sellador a base de silicona.
- Para evitar apretar demasiado, no utilice un destornillador eléctrico.
- Utilice arandelas al fijar con tornillos. No apriete demasiado los pernos.
- Utilice únicamente los tornillos suministrados con esta repisa.
- Para evitar rayar la repisa de la chimenea, el fuego debe insertarse por la parte trasera.

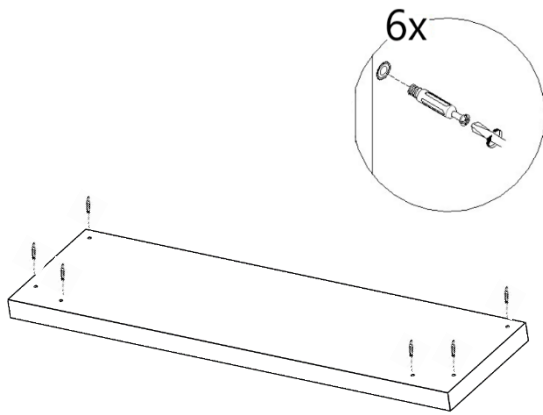

1. Con el destornillador, inserte 6 clavijas de leva en el panel de la base (K) como se muestra.

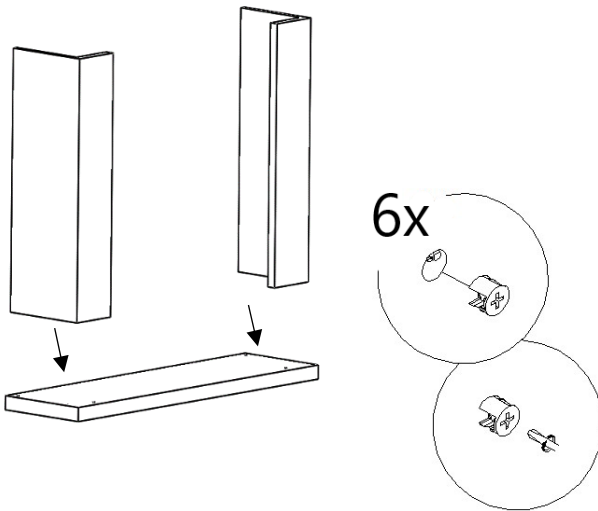

2. Deslice la pata de la mano derecha (C) y la pata de la mano izquierda (D) sobre el panel de la base (A), inserte las levas y apriete.

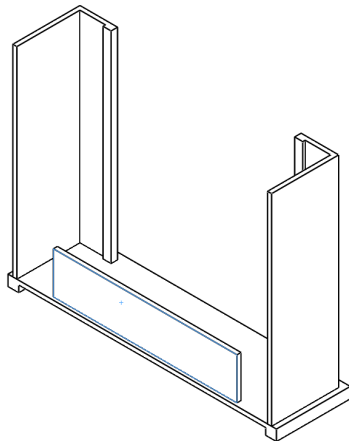

3. Fije el panel del estante trasero (J) con 7 tacos de madera.

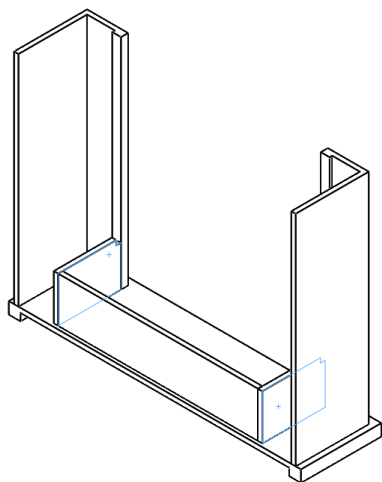

4. Fije el panel lateral izquierdo y derecho (G&H) en la pierna de la mano izquierda y la pierna de la mano derecha (C&D). Utilice 2 tornillos y arandelas M6x30 para cada lado

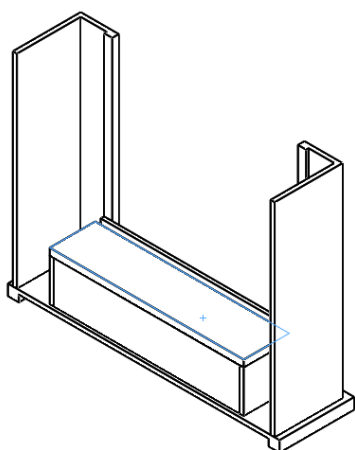

5. Fije el panel del estante superior (I) con 7 tacos de madera

Nota: asegúrese de que el cable LED del estante esté despejado al colocar el panel I

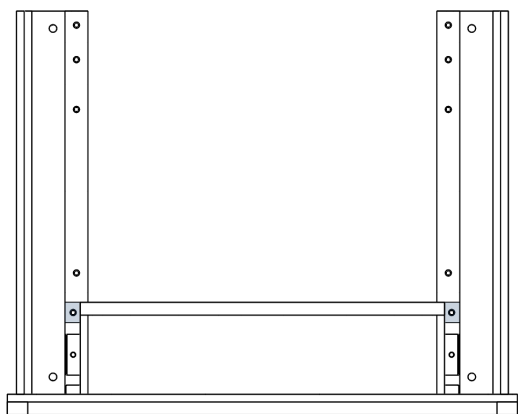

6. Fije el segundo panel inferior (F) a ambas patas (C y D) con 2 tornillos M6x30 y arandelas

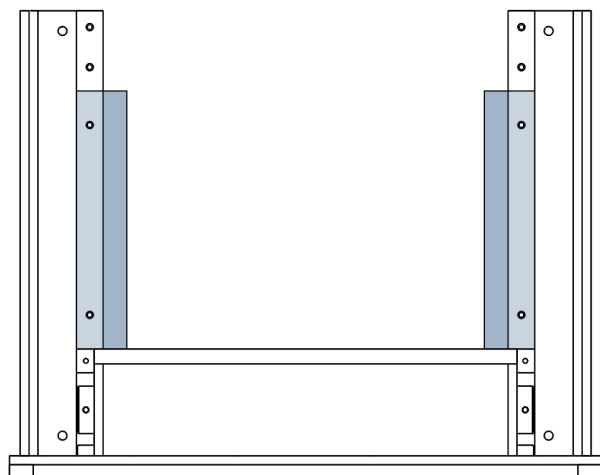

7. Fije los paneles de la segunda pata (L) a ambas patas (C y D) con 4 tornillos M6x30 y arandelas.

Nota: Se utilizan 2 tornillos y arandelas para cada lado.

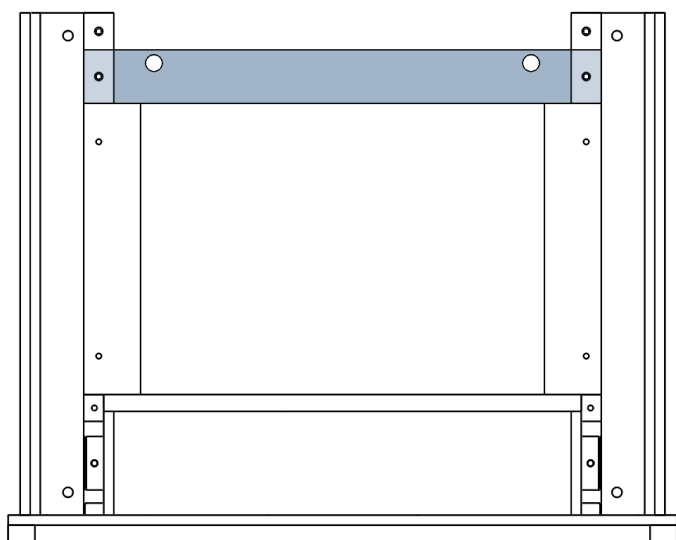

8. Fije el segundo panel superior (E) a ambas patas (C y D) con 2 tornillos M6x30 y arandelas

front of mood lighting

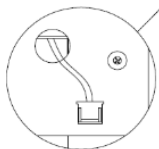
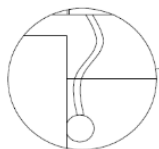

rear of mood lighting

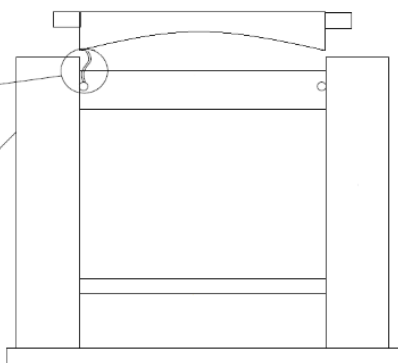

9. Pase el enchufe y el cable de la iluminación ambiental a través del orificio del panel lateral izquierdo (C) antes de fijar el panel frontal superior (B). Compruebe que la tira de LED todavía esté presionada firmemente hacia abajo en su posición en las almohadillas autoadhesivas.

Al colocar el panel frontal superior (B), utilice 2 tornillos M6x30 y arandelas y fíjelos a la pata del lado derecho y a la pata del lado izquierdo (C y D)

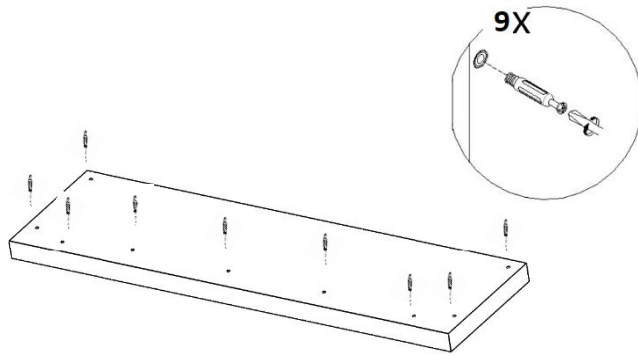

10. Con el destornillador, inserte los pasadores de leva 9x en el panel superior (A) como se muestra.

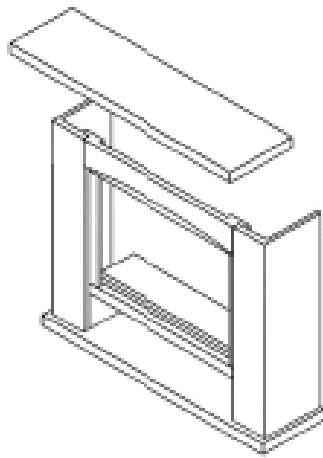

11. Fije el panel superior (A) al conjunto y apriete las levas desde la parte posterior de la repisa de la chimenea.

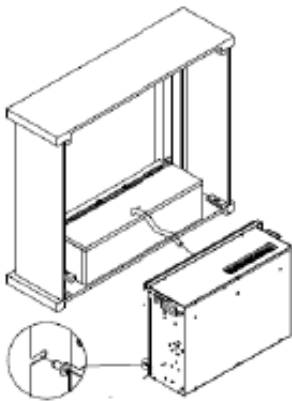

12. Instale el fuego desde la parte posterior de la repisa de la chimenea y use 4 tornillos para fijarlo firmemente. (Los tornillos se suministran junto con el fuego).

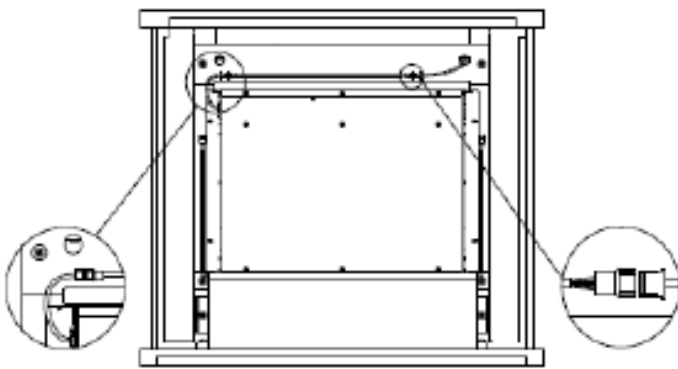

13. (A) Si solo desea utilizar la luz ambiental inferior, conecte los cables como se muestra en la imagen. Conecte los cables con el cable de extensión de 600 mm (Q) al fuego como se muestra en la imagen.

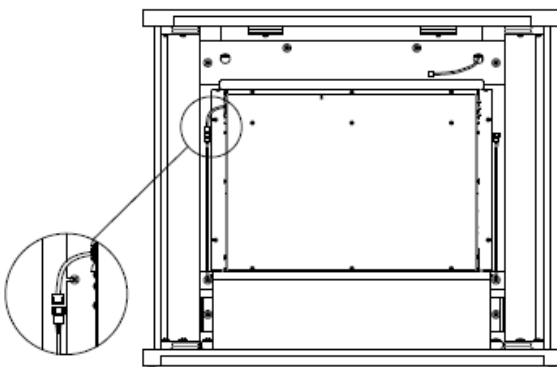

(B) Si solo desea utilizar la luz ambiental inferior, conecte los cables como se muestra en la imagen.

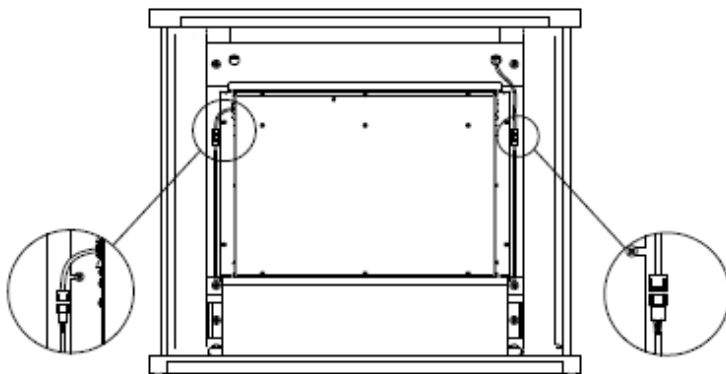

(C) Si desea utilizar ambas luces ambientales al mismo tiempo, conecte los cables como se muestra en la imagen.

SECCIÓN 3 LIMPIEZA Y MANTENIMIENTO

El revestimiento de la superficie de la repisa de la chimenea desprenderá un ligero olor durante un breve período inicial. Intente ventilar tanto como sea posible durante este tiempo.

Limpieza diaria:

- Limpie las superficies de la repisa con un paño suave que no suelte pelusa.
- No utilice productos de limpieza o pulido.

Evitar

- Luz solar directa de larga duración.
- Temperaturas y humedad excesivas para proteger la vida útil de la superficie de su mueble
- No coloque objetos pesados o afilados sobre esta repisa

SECCIÓN 1 DIMENSIONS

Dimensions en mm

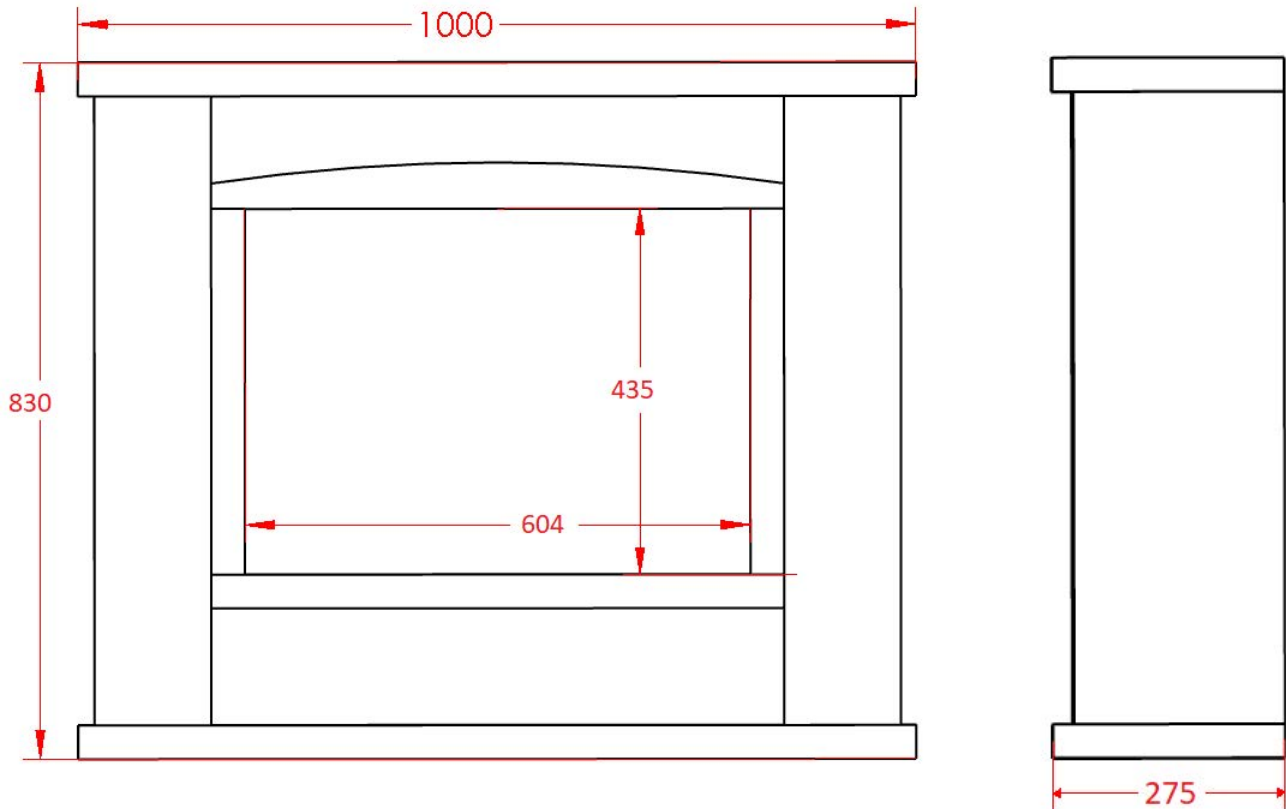



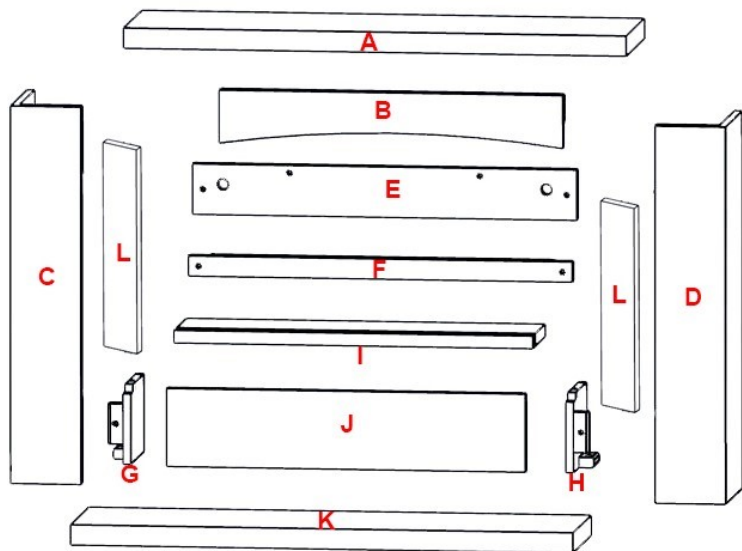

SECTION 2 ASSEMBLAGE ET INSTALLATION

2.1 Déballez

- Ouvrez l'emballage avec précaution et retirez toutes les pièces. Inspectez soigneusement chaque pièce pour tout dommage avant de commencer l'assemblage.
- Assurez-vous d'avoir toutes les pièces énumérées ci-dessous avant de procéder à l'assemblage.
- Conservez l'emballage pour un futur transport et/ou stockage.



No.	Nom	Quantité
A	Panneau du haut	1
B	Panneau LED curvo	1
C	Jambe de la main gauche	1
D	Jambe de la main droite	1
E	Deuxième panneau supérieur	1
F	Deuxième panneau inférieur	1
G	Panneau latéral gauche	1
H	Panneau latéral droit	1
I	Plateau supérieur	1
J	Panneau de tablette arrière	1
K	Panneau de fond	1
L	Deuxième panneau de jambe	2
M	Serrure à came et écrou 	15+3 Derechange
N	Cheville en bois 	14+3 Derechange
O	Vis M6X30mm 	14+3 Derechange
P	Machine à laver 	14+3 Derechange
Q	Rallonge LED - 460mm	1

REMARQUE : La gauche et la droite du produit se distinguent par leur vue de face.

2.2 Avant l'installation



Outils nécessaires : tournevis cruciforme magnétique

2.3 Installation

REMARQUE!

- Nécessite un assemblage par deux adultes.
- Cette suite avec foyer doit être fixée au mur. Des plaques de miroir sont fournies avec l'étagère, mais toute autre fixation dissimulée appropriée peut être utilisée. Ne pas utiliser de mastic à base de silicone.
- Pour éviter un serrage excessif, n'utilisez pas de tournevis électrique.
- Utilisez des rondelles lors de la fixation avec des vis. Ne pas trop serrer les boulons.
- Utilisez uniquement les vis fournies avec cette étagère.
- Pour éviter de rayer le manteau, le foyer doit être inséré par l'arrière.

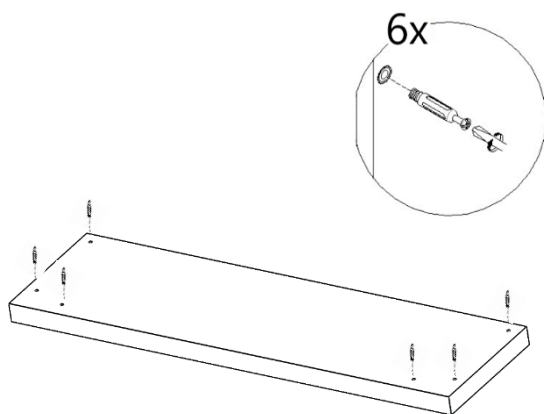

1. À l'aide du tournevis, insérez 6 broches à came dans le panneau de base (K) comme illustré.

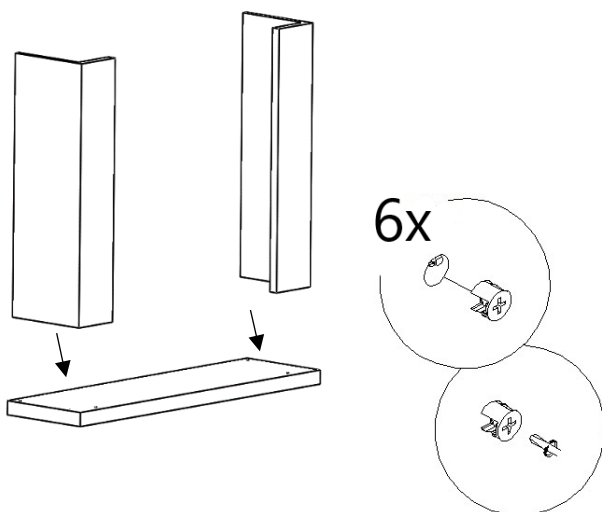

2. Faites glisser le pied droit (C) et le pied gauche (D) sur le panneau de base (A), insérez les cames et serrez.

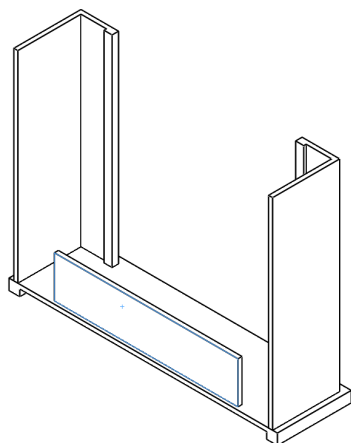

3. Fixez le panneau de tablette arrière (J) avec 7 chevilles en bois.

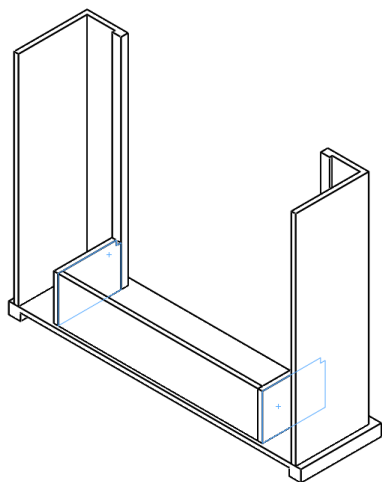

4. Fixez les panneaux latéraux gauche et droit (G&H) au pied gauche et au pied droit (C&D).
Utiliser 2 vis M6x30 et rondelles de chaque côté

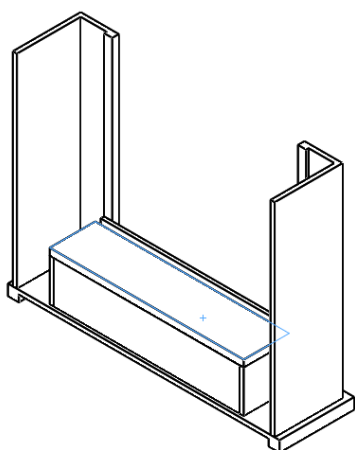

5. Fixez le panneau supérieur de l'étagère (I) avec 7 chevilles en bois

Remarque : Assurez-vous que le fil DEL de l'étagère est dégagé lors de la fixation du panneau I

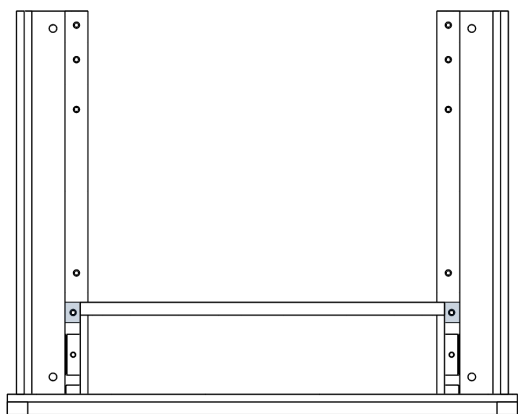

6. Fixez le deuxième panneau inférieur (F) aux deux pieds (C et D) avec 2 vis M6x30 et rondelles

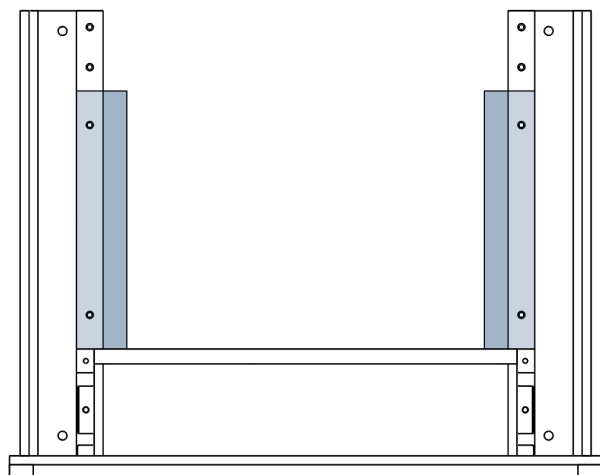

7. Fixez les panneaux du deuxième pied (L) aux deux pieds (C et D) à l'aide de 4 vis M6x30 et rondelles.

Remarque : 2 vis et rondelles sont utilisées pour chaque côté.

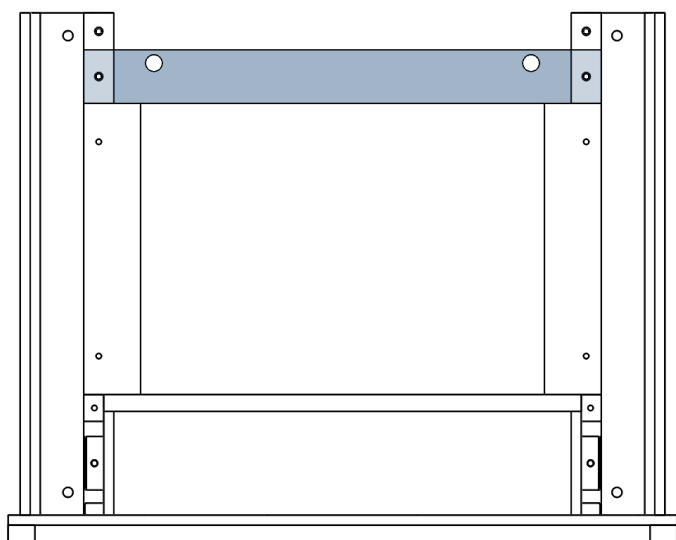

8. Fixez le deuxième panneau supérieur (E) aux deux pieds (C et D) avec 2 vis M6x30 et rondelles

front of mood lighting

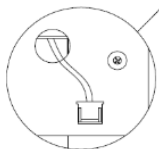
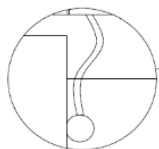

rear of mood lighting

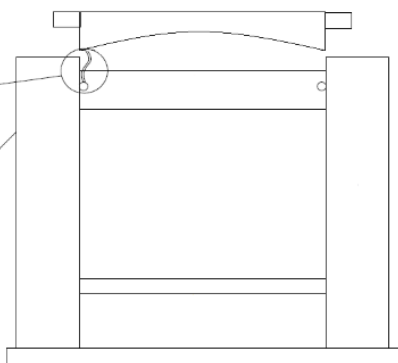

9. Faites passer la fiche et le cordon de l'éclairage ambiant par le trou du panneau latéral gauche (C) avant de fixer le panneau avant supérieur (B). Vérifiez que la bande LED est toujours fermement enfoncée en position sur les pastilles autocollantes. Lors de la fixation du panneau avant supérieur (B), utilisez 2 vis et rondelles M6x30 et fixez-les au pied latéral droit et au pied latéral gauche (C et D)

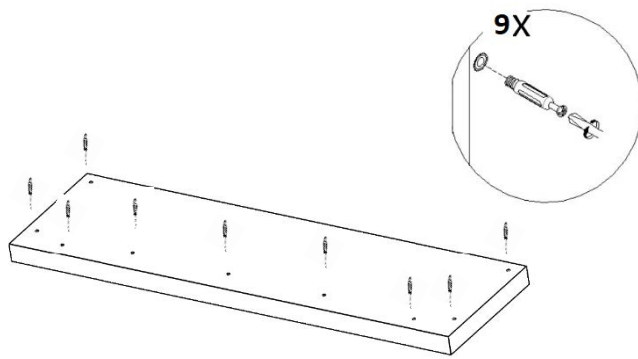

10. À l'aide du tournevis, insérez les 9 broches à came dans le panneau supérieur (A) comme illustré.

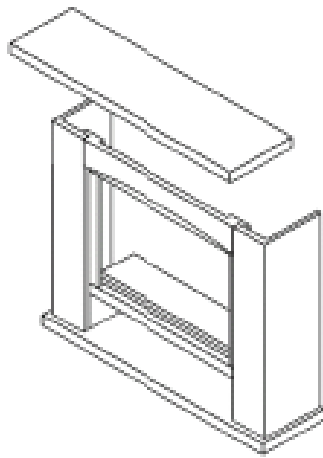

11. Fixez le panneau supérieur (A) à l'assemblage et pressez les comes à l'arrière du manteau.

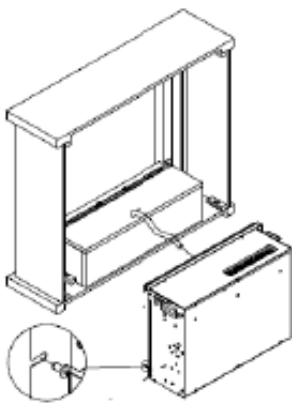

12. Installez le foyer à l'arrière du manteau et utilisez 4 vis pour le fixer solidement. (Les vis sont fournies avec le foyer).

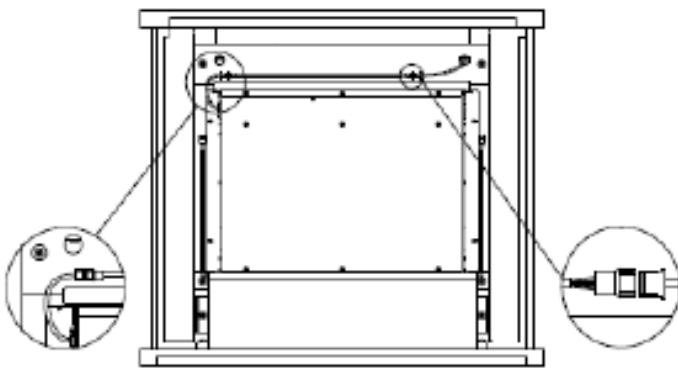

13. (A) Si vous souhaitez uniquement utiliser la lumière ambiante inférieure, veuillez connecter les câbles comme indiqué sur l'image. Connectez les fils avec la rallonge de 600 mm (Q) au feu comme indiqué sur l'image.

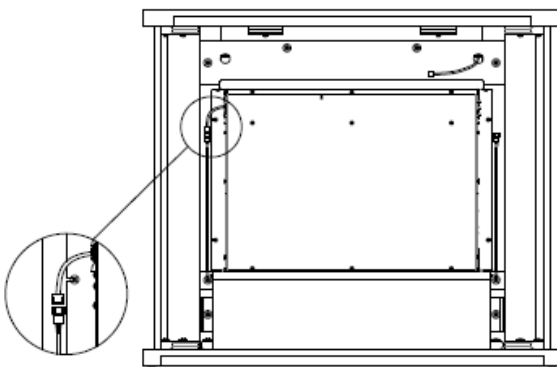

(B) Si vous souhaitez uniquement utiliser la lumière ambiante inférieure, veuillez connecter les câbles comme indiqué sur l'image.

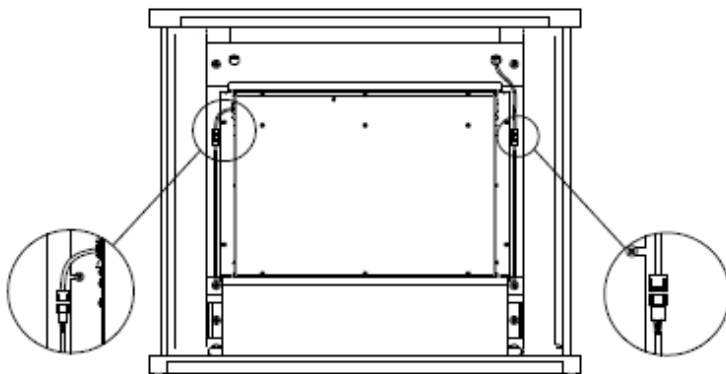

(C) Si vous souhaitez utiliser les deux lumières ambiantes en même temps, connectez les câbles comme indiqué sur l'image.

SECTION 3 NETTOYAGE ET ENTRETIEN

Le revêtement de surface du manteau dégagera une légère odeur pendant une courte période initiale. Essayez de ventiler autant que possible pendant cette période.

Ménage quotidien :

- Nettoyez les surfaces des étagères avec un chiffon doux non pelucheux.
- N'utilisez pas de produits de nettoyage ou de polissage.

Éviter

- Soleil direct de longue durée.
- Températures et humidité excessives pour protéger la durée de vie de la surface de votre meuble
- Ne placez pas d'objets lourds ou pointus sur cette étagère