



YEEGO VERTICAL SHOWCASE
INSTRUCTION MANUAL

Who are we?

Yeego, the perfect fusion of fashion and innovation. We are a factory seller specializing in wine cooler and beverage refrigerator.

We pursue fashionable design and innovative technology to create a space full of personality and modernity for you.

Whether you are a connoisseur who loves wine tasting, or a host looking to add unique charm to family gatherings, Yeego products can meet your needs.

Choose Yeego, let us create a fashionable, innovative and wonderful life experience together.



<https://yeegolife.com/>



<https://www.facebook.com/yeegolife.official>

TABLE OF CONTENTS

Safety Information & Warnings	01
Main Parts	04
Installation Instructions	06
Correct Disposal Of This Product	06
Technical Parameter	07
Container Loading List	07
Operation Instruction	08
Alarm Code & Alarm Reason	09
Harmful Substances	09
Maintenance & Cleaning	10
Trouble Shooting	16
Warranty Instructions	18
Customer Service	19

SAFETY INFORMATION & WARNINGS

Attention: Child Entrapment Risk!

- This appliance is not intended for use by persons (including children) with reduced physical, sensory or mental capabilities, or lack of experience and knowledge, unless they have been given supervision or instruction concerning use of the appliance by a person responsible for their safety.
- Children should be supervised to ensure that they do not play with the appliance.
- This appliance can be used by children aged from 8 years and above and persons with reduced physical, sensory or mental capabilities or lack of experience and knowledge if they have been given supervision or instruction concerning use of the appliance in a safe way and understand the hazards involved. Children shall not play with the appliance. Cleaning and user maintenance shall not be made by children without supervision.



Important Precautions:

- If the supply cord is damaged, it must be replaced by the manufacturer, its service agent or similarly qualified persons in order to avoid a hazard.
- Do not store explosive substances such as aerosol cans with a flammable propellant in this appliance.
- WARNING: Keep clear of obstruction all ventilation openings in the.
- WARNING: Do not use mechanical devices or other means to accelerate the defrosting process, other than those recommended by the manufacturer.
- WARNING: Do not damage the refrigerating circuit.
- WARNING: Do not use electrical appliances inside the food/ice storage compartments unless they are of the type recommended by the manufacturer.
- The A-weighted emission sound pressure level is below 70 dB(A).
- The appliance shall be disconnected from its power source during cleaning or maintenance and when replacing parts. The removal of the plug has to be such that an operator can check from any of the points to which he has access that the plug remains removed.



Shock Hazard –Electrical Grounding Required

- This machine alone uses the standard 10A or above the three-hole socket. In any case, ensure that the power outlet used is connected to the ground wire and do not modify the power cord and plug.
- Do not damage the power cord or use a damaged power cord at any time.

- When there is a flammable gas leakage, do not unplug the power plug, so as not produce a spark and cause a fire, should immediately close the gas source, Window opening for ventilation and exhaust.
- Do not put the product in a wet, easy to splash to the water place, do not spray with water, wash the product so as not to affect the electrical insulation.
- When moving the product, the power plug should be pulled out first. If there are items in the cabinet, remove the items, and then move slowly with the help of the bottom caster. If you want to push from some distance please use a cart.
- When abandoned it, make sure the product is away from fire to prevent accidents. Please remove the door to prevent children from entering and play. And the abandoned product should be submitted to the waste electrical and electronic products processing qualification enterprises.
- Maximum load-bearing of each shelf: 30kg, do not overload, otherwise it will lead to product damage.



WARNING

- Do not use means to accelerate the defrosting process or to clean, other than those recommended by the manufacturer.
- The appliance shall be stored in a room without continuously operating ignition sources (for example: open flames, an operating gas appliance or an operating electric heater).
- Do not pierce or burn.
- Be aware that refrigerants may not contain an odour.

WARNING - Keep all required ventilation openings clear of obstruction. Servicing must be performed only as recommended by the manufacturer.



MAIN PARTS

Adapt to the model:
SC-380FC/SC-530FC

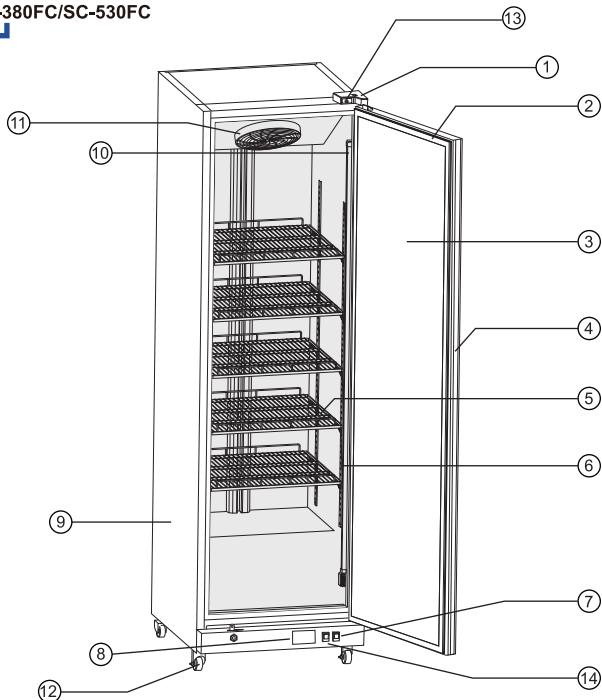

- | | | | |
|-----------|-------------------------------|-----------|-----------------------------|
| 1 | Right door hinge | 2 | Door seal |
| 3 | Glass door | 4 | Handle |
| 5 | Shelves | 6 | K clip |
| 7 | Light switch | 8 | Thermostat |
| 9 | Cabinet | 10 | Inside LED light |
| 11 | Evaporator fan | 12 | Universal casters |
| 13 | Door controlled switch | 14 | Refrigeration switch |

Adapt to the model:
SC-760FC/SC-1060FC

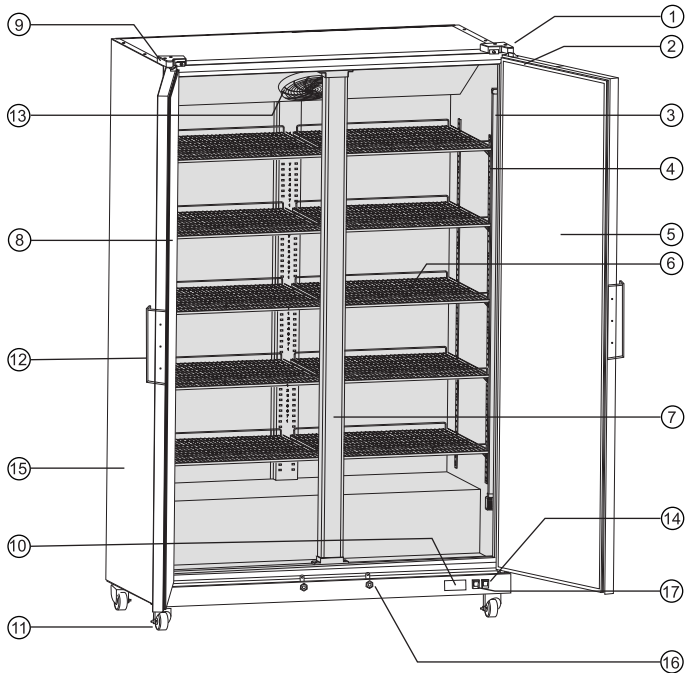

1 Right door hinge

2 Door seal

3 Inside LED light

4 K clip

5 Right glass door

6 Shelves

7 Middle partition

8 Left glass door

9 Light door hinge

10 Thermostat

11 Universal casters

12 Handle

13 Evaporator fan

14 Light switch

15 Cabinet

16 Door controlled switch

17 Refrigeration switch

INSTALLATION INSTRUCTIONS

- Power sockets must be installed with a reliable grounding wire to ensure safety.
- Do not share sockets with other electrical appliances to avoid wire overheating and catching fire.
- Install the product in a well-ventilated, dry and cool place to avoid direct sunlight and stay away from various heat sources and gas appliances or electrical appliances.
- When installing the ground, ensure that the product should not be tilted to prevent the goods from falling out.
- Make sure to leave min.100 mm space for back and each side.
- Carefully check other factors that may cause the machine to be fixed reliably to prevent accidents.
- Before installation, check the strength and surface flatness of the installation part, otherwise it may cause the skew and dislocation of the door.
- The power socket shall be set within 1.2m from the power cord lead outlet of the housing.

CORRECT DISPOSAL OF THIS PRODUCT



This symbol on the product or its packaging indicates that it should not be treated as household waste. Instead, it must be taken to a designated waste collection point for recycling electrical and electronic equipment. Proper disposal helps prevent potential negative impacts on the environment and human health that could result from improper handling. For more information about recycling this product, please contact your local council, waste disposal service, or the store where you purchased it.

TECHNICAL PARAMETER

Model	Net volume (CU.FT)	Rated voltage (V~)	Rated frequency (Hz)	Rated current (A)	Rated power (W)	Net weight (LB)	Product size W*D*H (INCH)
SC-380FC	12.4	115	60	2.4	260	169.8	21.7×23.9×75.8
SC-530FC	17.5	115	60	2.5	270	205	24.8×26.3×80.4
SC-760FC	27.1	115	60	3.5	350	282.2	44.1×25×75.8
SC-1060FC	37.8	115	60	3.7	370	329.6	50.2×27.4×80.4

CONTAINER LOADING LIST

Model	Instructions	Shelves	K clip	Handle
SC-380FC	1	5	22	0
SC-530FC	1	5	22	0
SC-760FC	1	10	42	2
SC-1060FC	1	10	42	2

INSTALL DOOR HANDLES

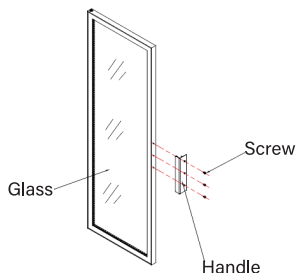



Adapt to the model: SC-760FC / SC-1060FC



- The unit has been shipped with the door handle securely stored inside, attached to the shelves.
- Verify the handle's orientation using the provided diagram. Attach it to the door frame with the three supplied screws. Ensure proper alignment before tightening to avoid damaging the glass. If misaligned, adjust the handle and realign before securing.

OPERATION INSTRUCTION

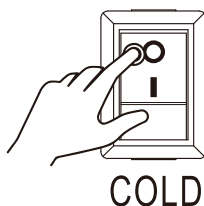

- In temperature measuring and controlling mode, pressing and holding the key "  " for three seconds will toggle between refrigeration, defrost/defrost delay, and defrost dripping modes.
- During the parameter setting process, after pressing the "  " key, you can adjust the parameter by pressing any key within 30 seconds. After 30 seconds, the system will automatically save the current parameter value and exit the parameter setting mode. If you need to modify the set value again, you need to press the "  " to set it again.
- In temperature measuring and controlling mode, press and hold the Set key for three seconds to enter the user menu, where the code "Set" will be displayed. Press the Set key again to view the current value of "Set," which can be adjusted using the ▲ (increase) and ▼ (decrease) keys.



- Press  switch to turn the LED light on / off. Press "I" to turn it on and "O" to turn it off.
- Press  switch to open / close the refrigeration system, press "I" to open or press "O" to close.

ALARM CODE & ALARM REASON

- E1:Cabinet temperature sensor failure.
- rH:Cabinet high temperature alarm.
- rL:Cabinet low temperature alarm.

NAME AND CONTENT OF HARMFUL SUBSTANCES IN THE PRODUCT

Name and content of harmful substances in the product

Part name	Hazardous material					
	Pb	Hg	Cd	Cr(VI)	PBB	PBDE
Insulating layer	<input type="radio"/>	<input type="radio"/>	<input type="radio"/>	<input type="radio"/>	<input type="radio"/>	<input type="radio"/>
Refrigerant	<input type="radio"/>	<input type="radio"/>	<input type="radio"/>	<input type="radio"/>	<input type="radio"/>	<input type="radio"/>
Fastener	<input type="radio"/>	<input type="radio"/>	<input type="radio"/>	<input type="radio"/>	<input type="radio"/>	<input type="radio"/>
Power supply cord Connecting line	<input type="radio"/>	<input type="radio"/>	<input type="radio"/>	<input type="radio"/>	<input type="radio"/>	<input type="radio"/>
Plastic parts	<input type="radio"/>	<input type="radio"/>	<input type="radio"/>	<input type="radio"/>	<input type="radio"/>	<input type="radio"/>
Shelves	<input type="radio"/>	<input type="radio"/>	<input type="radio"/>	<input type="radio"/>	<input type="radio"/>	<input type="radio"/>
Thermostat	<input checked="" type="radio"/>	<input type="radio"/>	<input type="radio"/>	<input type="radio"/>	<input type="radio"/>	<input type="radio"/>
Fan, Motor	<input type="radio"/>	<input type="radio"/>	<input type="radio"/>	<input type="radio"/>	<input type="radio"/>	<input type="radio"/>
Refrigeration tube	<input type="radio"/>	<input type="radio"/>	<input type="radio"/>	<input type="radio"/>	<input type="radio"/>	<input type="radio"/>
Packing material	<input type="radio"/>	<input type="radio"/>	<input type="radio"/>	<input type="radio"/>	<input type="radio"/>	<input type="radio"/>
Metal parts	<input type="radio"/>	<input type="radio"/>	<input type="radio"/>	<input type="radio"/>	<input type="radio"/>	<input type="radio"/>
Sensor	<input checked="" type="radio"/>	<input type="radio"/>	<input type="radio"/>	<input type="radio"/>	<input type="radio"/>	<input type="radio"/>

MAINTENANCE & CLEANING

- To maintain the cabinet's performance, keep its surface clean and remove dust frequently. Avoid using water for cleaning, as it can affect the insulation performance of the electrical components. Always cut off the power supply before cleaning. Use a soft cloth dampened with water or a mild detergent, and then wipe away any detergent residue with clean water.
- Do not use hard or sharp cleaning tools, as they can damage the protective layer of the appliance. Avoid acidic or alkaline detergents, oils, boiling water, brushes, or other abrasive cleaning agents.
- After cleaning, reconnect the power and check that the switch or thermostat is in the correct setting. If frost builds up inside the cabinet, remove the items, open the door, and allow it to defrost naturally. Do not use metal or sharp tools to scrape off frost, as this can damage the walls or puncture the refrigeration pipes.
- If the product will not be used for an extended period, unplug it, clean the cabinet thoroughly, and allow it to dry completely before closing the door and covering it with a protective bag.

REPAIR AND MAINTENANCE TO ELECTRICAL COMPONENTS SHALL INCLUDE INITIAL SAFETY CHECKS AND COMPONENT INSPECTION PROCEDURES.

- If a fault exists that could compromise safety, then no electrical supply shall be connected to the circuit until it is satisfactorily dealt with. If the fault cannot be corrected immediately but it is necessary to continue operation, an adequate temporary solution shall be used. This shall be reported to the owner of the equipment, so all parties are advised.

INITIAL SAFETY CHECKS SHALL INCLUDE:

- that capacitors are discharged: this shall be done in a safe manner to avoid possibility of sparking;
- that there is continuity of earth bonding.
- that no live electrical components and wiring are exposed while charging, recovering or purging the system;

PRIOR TO BEGINNING WORK ON SYSTEMS CONTAINING FLAMMABLE REFRIGERANTS, SAFETY CHECKS ARE NECESSARY TO ENSURE THAT THE RISK OF IGNITION IS MINIMISED.

For repair to the REFRIGERATING SYSTEM, the following step a) -e) should be completed prior to conducting work on the system.

- a) The serving work must be undertaken under a controlled procedure so as to minimise the risk of a flammable gas or vapour being present while the work is being performed.
- b) All maintenance staff and others working in the local area must be instructed on the nature of work being carried out. Serving work in confined spaces need to be avoided.

- c) The area shall be checked with an appropriate refrigerant detector prior to and during work, to ensure the technician is aware of potentially toxic or flammable atmospheres. Ensure that the leak detection equipment being used is suitable for use with all applicable refrigerants, i.e., nonsparking, adequately sealed, or intrinsically safe.
 - d) If any hot work is to be conducted on the refrigerating equipment or any associated parts, appropriate fire extinguishing equipment shall be available on hand. A dry chemical or CO₂ fire extinguisher should be adjacent to the charging area.
 - e) No person carrying out work in relation to a REFRIGERATING SYSTEM which involves exposing any pipe work shall use any sources of ignition in such a manner that it may lead to the risk of fire or explosion. All possible ignition sources, including cigarette smoking, should be kept sufficiently far away from the site of installation, repairing, removing and disposal, during which refrigerant can possibly be released to the surrounding space. Prior to work taking place, the area around the equipment shall be surveyed to make sure that there are no flammable hazards or ignition risks. "No Smoking" signs shall be displayed.
- Ensure that the area is in the open or that it is adequately ventilated before breaking into the system or conducting any hot work. A degree of ventilation shall continue during the period that the work is carried out. The ventilation should safely disperse any released refrigerant and preferably expel it externally into the atmosphere.
 - Where electrical components are being changed, they shall be fit for the purpose and to the correct specification. At all times, the manufacturer's maintenance and service guidelines shall be followed. If in doubt, consult the manufacturer's technical department for assistance.

THE FOLLOWING CHECKS SHALL BE APPLIED TO INSTALLATIONS USING FLAMMABLE REFRIGERANTS:

- the actual REFRIGERANT CHARGE is in accordance with the room size within which the refrigerant containing parts are installed;
- if an indirect refrigerating circuit is being used, the secondary circuit shall be checked for the presence of refrigerant;
- marking to the equipment continues to be visible and legible. Markings and signs that are illegible shall be corrected;
- the ventilation machinery and outlets are operating adequately and are not obstructed;
- refrigerating pipe or components are installed in a position where they are unlikely to be exposed to any substance which may corrode refrigerant containing components, unless the components are constructed of materials which are inherently resistant to being corroded or are suitably protected against being so corroded.

- Repair and maintenance to electrical components shall include initial safety checks and component inspection procedures. If a fault exists that could compromise safety, then no electrical supply shall be connected to the circuit until it is satisfactorily dealt with. If the fault cannot be corrected immediately but it is necessary to continue operation, an adequate temporary solution shall be used. This shall be reported to the owner of the equipment, so all parties are advised.

WHEN REPAIRS TO SEALED COMPONENTS:

- During repairs to sealed components, all electrical supplies shall be disconnected from the equipment being worked upon prior to any removal of sealed covers, etc. If it is absolutely necessary to have an electrical supply to equipment during servicing, then a permanently operating form of leak detection shall be located at the most critical point to warn of a potentially hazardous situation.
- Particular attention shall be paid to the following to ensure that by working on electrical components, the casing is not altered in such a way that the level of protection is affected. This shall include damage to cables, excessive number of connections, terminals not made to original specification, damage to seals, incorrect fitting of glands, etc.
- Ensure that the apparatus is mounted securely.
- Ensure that seals or sealing materials have not degraded to the point that they no longer serve the purpose of preventing the ingress of flammable atmospheres. Replacement parts shall be in accordance with the manufacturer's specifications.

REPAIR TO INTRINSICALLY SAFE COMPONENTS:

- -Do not apply any permanent inductive or capacitance loads to the circuit without ensuring that this will not exceed the permissible voltage and current permitted for the equipment in use. -Intrinsically safe components are the only types that can be worked on while live in the presence of a flammable atmosphere. The test apparatus shall be at the correct rating. -Replace components only with parts specified by the manufacturer. Other parts can result in the ignition of refrigerant in the atmosphere from a leak.
- Check that cabling will not be subject to wear, corrosion, excessive pressure, vibration, sharp edges, or any other adverse environmental effects. The check shall also take into account the effects of aging or continual vibration from sources such as compressors or fans.

DETECTION OF FLAMMABLE REFRIGERANTS:

- - Under no circumstances shall potential sources of ignition be used in the searching for or detection of refrigerant leaks. A halide torch (or any other detector using a naked flame) shall not be used.

THE FOLLOWING LEAK DETECTION METHODS ARE DEEMED ACCEPTABLE:

- Electronic leak detectors may be used to detect refrigerant leaks but, in the case of FLAMMABLE REFRIGERANTS, the sensitivity might not be adequate, or might need recalibration. (Detection equipment shall be calibrated in a refrigerant-free area.) Ensure that the detector is not a potential source of ignition and is suitable for the refrigerant used. Leak detection equipment shall be set at a percentage of the LFL of the refrigerant and shall be calibrated to the refrigerant employed, and the appropriate percentage of gas (25 % maximum) is confirmed.
- Leak detection fluids are also suitable for use with most refrigerants but the use of detergents containing chlorine shall be avoided as the chlorine can react with the refrigerant and corrode the copper pipe-work.
- If a leak is suspected, all naked flames shall be removed/extinguished.
- If a leakage of refrigerant is found which requires brazing, all of the refrigerant shall be recovered from the system, or isolated (by means of shut off valves) in a part of the system remote from the leak. Removal of refrigerant shall be according to instruction of removal and evacuation.

REMOVAL AND EVACUATION:

- When breaking into the refrigerant circuit to make repairs – or for any other purpose – conventional procedures shall be used. However, for flammable refrigerants it is important that best practice be followed, since flammability is a consideration. The following procedure shall be adhered to:
 - a) safely remove refrigerant following local and national regulations;
 - b) purge the circuit with inert gas;
 - c) evacuate (optional for A2L);
 - d) purge with inert gas (optional for A2L);
 - e) open the circuit by cutting or brazing.
- The refrigerant charge shall be recovered into the correct recovery cylinders if venting is not allowed by local and national codes. For appliances containing flammable refrigerants, the system shall be purged with oxygen-free nitrogen to render the appliance safe for flammable refrigerants. This process might need to be repeated several times. Compressed air or oxygen shall not be used for purging refrigerant systems.
- For appliances containing flammable refrigerants, refrigerants purging shall be achieved by breaking the vacuum in the system with oxygen-free nitrogen and continuing to fill until the working pressure is achieved, then venting to atmosphere, and finally pulling down to a vacuum. This process shall be repeated until no refrigerant is within the system. When the final oxygen-free nitrogen charge is used, the system shall be vented down to atmospheric pressure to enable work to take place.
- Ensure that the outlet for the vacuum pump is not close to any potential ignition sources and that ventilation is available.

CHARGING PROCEDURES:

- In addition to conventional charging procedures, the following requirements shall be followed.
 - a) Ensure that contamination of different refrigerants does not occur when using charging equipment. Hoses or lines shall be as short as possible to minimise the amount of refrigerant contained in them.
 - b) Cylinders shall be kept in an appropriate position according to the instructions.
 - c) Ensure that the REFRIGERATING SYSTEM is earthed prior to charging the system with refrigerant.
 - d) Label the system when charging is complete (if not already).
 - e) Extreme care shall be taken not to overfill the REFRIGERATING SYSTEM.
- Before recharging the system, it shall be pressure-tested with the appropriate purging gas. After charging and before commissioning, the system shall undergo a leak test. Additionally, a follow-up leak test must be performed before leaving the site.

DECOMMISSIONING:

- Before carrying out this procedure, it is essential that the technician is completely familiar with the equipment and all of its details. It is recommended good practice to ensure that all refrigerants are recovered safely. An oil and refrigerant sample shall be taken prior to the task in case analysis is required prior to reuse of the recovered refrigerant. It is essential that electrical power is available before the task is started.
 - a) Become familiar with the equipment and its operation.
 - b) Isolate the system electrically.
 - c) Before attempting the procedure, ensure that:
 - i) mechanical handling equipment is available, if required, for handling refrigerant cylinders;
 - ii) all personal protective equipment is available and being used correctly;
 - iii) the recovery process is supervised at all times by a competent person;
 - iv) recovery equipment and cylinders conform to the appropriate standards.
 - d) Pump down refrigerant system, if possible.
 - e) If a vacuum is not possible, make a manifold so that refrigerant can be removed from various parts of the system.
 - f) Make sure that cylinder is situated on the scales before recovery takes place.
 - g) Start the recovery machine and operate in accordance with instructions.
 - h) Do not overfill cylinders (no more than 80 % volume liquid charge).
 - i) Do not exceed the maximum working pressure of the cylinder, even temporarily.

- j) When the cylinders have been filled correctly and the process completed, make sure that the cylinders and the equipment are removed from site promptly and all isolation valves on the equipment are closed off.
- k) Recovered refrigerant shall not be charged into another REFRIGERATING SYSTEM unless it has been cleaned and checked.
- The equipment shall be labeled to indicate that it has been taken out of service and emptied of refrigerant. The label shall be dated and signed. For equipment containing FLAMMABLE REFRIGERANT, ensure that labels are attached to the equipment indicating that the equipment contains FLAMMABLE REFRIGERANT.

RECOVERY:

- When removing refrigerant from a system, either for service or decommissioning, it is good practice to safely remove all refrigerant.
- When transferring refrigerant to cylinders, ensure that only appropriate refrigerant recovery cylinders are used. Ensure that the correct number of cylinders are available to hold the total system charge. All cylinders to be used shall be designated for the recovered refrigerant and labeled for that refrigerant (i.e., special cylinders for the recovery of refrigerant). Cylinders shall be complete with pressure relief valve and associated isolation valves in good working order. Empty recovery cylinders shall be evacuated and, if possible, cooled prior to recovery.
- The recovery equipment shall be in good working order with a set of instructions for the equipment and shall be capable of recovering all appropriate refrigerants including, where applicable, FLAMMABLE REFRIGERANTS. In addition, a set of calibrated scales shall be available and in good working order. Hoses must be complete with leak-free disconnect couplings and in good condition. Before using the recovery machine, check that it is in satisfactory working order, has been properly maintained and that all associated electrical components are sealed to prevent ignition in the event of a refrigerant release. If in doubt, please consult the manufacturer.
- The recovered refrigerant shall be returned to the refrigerant supplier in the correct recovery cylinder and the appropriate waste transfer note arranged. Do not mix refrigerants in recovery units and especially not in cylinders.
- If compressors or compressor oils are to be removed, ensure that they have been evacuated to an acceptable level to ensure that no FLAMMABLE REFRIGERANT remains in the lubricant. The evacuation process shall be performed before the compressor is returned to the supplier. Only electrical heating of the compressor body may be used to expedite this process. When oil is drained from a system, it shall be carried out safely.

TROUBLE SHOOTING

Fault content	Failure cause	Trouble shooting
No cooling	There is no electricity on the socket	Check whether the socket is connected
	Whether the voltage is stable	Check the voltage on the socket is normal
	The refrigeration switch is not turned on or damaged	Check whether the refrigeration switch is turned on. If the switch is faulty, it will need to be replaced
	The temperature control knob is not set in place	Check that the temperature control knob is in the right position
	Refrigeration system failure	Inform professionals to repair the refrigeration system
The cooling performance is poor	Insufficient ventilation and heat dissipation of the refrigeration system	Check that the air vents are blocked
	The product is exposed directly to the sunlight	Place the appliance in a location away from direct sunlight
	The door seal of the product is not sealed after aging	Replace the door seal
	The indoor ambient temperature is too high	Ensure proper indoor ventilation and keep the room temperature below 89.6°F
	Airflow obstruction inside the cabinet	Ensure that the air duct of the product is unobstructed and not blocked
	Fan does not turn	Inform professionals to replace the fan
The compressor does not stop	The product is exposed directly to the sunlight	Place the appliance in a location away from direct sunlight
	The thermostat setting temperature is too low	Reduce the thermostat setting temperature
	Insufficient ventilation and heat dissipation in the refrigeration system	Ensure adequate ventilation space is left around the unit
	Refrigeration system failure	Inform professionals to repair the refrigeration system

There is a peculiar smell in the cabinet	Newly purchased product insulation material taste	Place the product in the ventilated place, and open the cabinet door for ventilation
	Items in the cabinet have expired and deteriorated	Regularly check and clean up spoiled items
	The cabinet is not level, resulting in water accumulation.	Move the cabinet to the level to ensure the water is drained
	Pollution in the cabinet	Clean the water and pollutants in the cabinet regularly to ensure clean and tidy
Alarm code E1	1. Check whether the sensor is properly connected to the thermostat	
	2. Verify the sensor's resistance value. At an ambient temperature of 77°F, the resistance should be approximately 10 kΩ. If the resistance value is abnormal (e.g., no reading or less than 1 kΩ at normal temperature), the internal wire or the sensor terminal at the cabinet outlet may be damaged. Locate the damaged section and repair or replace the sensor as needed.	
	3. If the issue persists after completing checks in steps 1–2, you need to replace the thermostat.	
Alarm code rH	1. Check for any air leakage, frequent door openings while the power is on, or placing too many hot items into the cabinet at once.	
	2. Check whether the fan is not working;	
	3. Check whether the compressor is not working;	
	4. Check whether the system has any faults such as refrigerant leakage;	
Alarm code rL	1. Check if the sensor is properly in contact with the evaporator.	
	2. Ensure the sensor is securely connected to the thermostat.	
	3. Verify the sensor's resistance value. At an ambient temperature of 77°F, the resistance should be approximately 10 kΩ. If the resistance value is abnormal (e.g., no reading or less than 1 kΩ at normal temperature), the internal wire or the sensor terminal at the cabinet outlet may be damaged. Locate the damaged section and repair or replace the sensor as needed.	
	4. If the issue persists after completing checks in steps 1–2, you need to replace the thermostat.	

WARRANTY INSTRUCTIONS

1 Year Warranty Parts

Within one year (12 months) from the date of original delivery, we will provide free replacement parts for any component that is found to be defective in materials or workmanship, including installation support via video or online guide. For additional assistance, please contact our support team by email. This warranty covers all parts required to remedy such defects, provided that the unit has been properly installed and operated in accordance with the instructions specified in this manual.

3 Year Warranty Compressor

For the 2nd through the 3rd year from date of original purchase, we will provide a replacement compressor free of charge in case of failure.

You are responsible for service labor and freight charges. Any costs associated with moving the beverage refrigerator to and from the service center are the user's responsibility.

What Is Not Covered

The following situations are not covered under the warranty. The user will be responsible for the cost of materials and repair services in these cases:

- Damage caused by failure to follow operating instructions.
- Damage resulting from the use of incompatible power sources or non-approved components.
- Damage due to improper installation or failure to comply with the user manual.
- Damage caused by human error, misuse, or accidents.
- Damage caused by unauthorized repairs or modifications without prior approval from the company.
- Normal wear and tear, including surface aging or scratches.
- Claims made after the one-year free warranty period.

Matters Need Attention

- If you encounter any quality issues during use, please contact our customer service team and provide this warranty card. Once we verify your information and the product's factory number, we will arrange warranty service as soon as possible.
- After the free warranty period expires, you may still access our paid maintenance service, for which standard repair fees will apply.
- Please keep this warranty card in a safe place after purchase. Warranty claims will not be accepted without the original warranty card.

CUSTOMER SERVICE

Read This Guide Carefully.

Please keep the original proof of purchase (such as your sales receipt) with this manual to confirm the warranty period.

Save time and money-before contacting customer service, refer to the Troubleshooting Guide. It lists common issues and easy solutions you can try yourself.

User information

Name : _____

Tel : _____

Address: _____

Product information

Product model : _____

Purchase date : _____

Contact Us

We take pride in delivering excellent service and strive to ensure your satisfaction. If you have any questions or concerns, please reach out to the customer services who serviced your beverage refrigerator and explain your concerns. In many cases, they can address and resolve the issue directly.

Email Us: Please feel free to contact us via our after-sales email address (service@yeegolife.com)

Maintenance date	Fault content		Maintenance unit	Maintenance person
	Fault situation	Replace accessories		

Activate Warranty & Join Us

VISIT: <https://yeego.vip/>
or scan the QR code



Email: service@yeegolife.com

*Activate Product Warranty

*VIP Exclusive Service

*Personalized product care & records

Just let us know if you have any questions about our products!