

# Swivel Stool



Made in Vietnam

Updated V. 12-2020



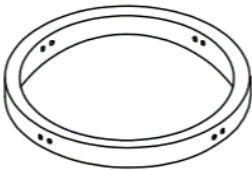
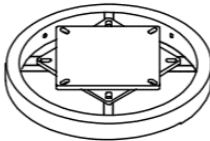

## Pre-Assembly Instructions

- Read all instructions carefully before assembly.
- Find a smooth clean area in which to work to avoid damaging your item.
- Check that all parts and hardware from the lists are present.
- Lay out parts in order and hardware in order to make them easier to find when you are ready to assemble
- Wait to dispose of packing material until assembly is complete to avoid accidentally disposing of small parts or hardware
- Tools required: Allen wrench (included)
- Please use caution and care when lifting the product to avoid injury
- For ease of assembly two people are recommended

## Parts List:

<p>A. Seat Cushion Qty: 1</p> 	<p>B. Legs Qty: 4</p> 
<p>C. Round Stretcher Qty: 1</p> 	<p>D. Round Support Apron Qty: 1</p> 

## Hardware List:

<p>1. Allen Wrench Qty: 1</p>  <p>Size 4mm</p>	<p>2. Flat Washer Qty: 20</p>  <p>Size 6x20mm</p>	<p>3. Spring Washer Qty: 20</p>  <p>Size 6x10mm</p>
<p>4. Bolt Qty: 4</p>  <p>Size 6x25mm</p>	<p>5. Bolt Qty: 16</p>  <p>Size 6x40mm</p>	

## Assembly Instructions:

### Step 1

**Wait to fully tighten all leg hardware until the end of Step 1.**

- A. Use eight Bolts (5), eight Spring Washers (3), and eight Flat Washers (2), to **loosely** attach the Round Support Apron (D) to the top of the Legs (B).
- B. Place Round Stretcher (C) in the grooves in the center of the Legs (B)  
**TIP: Keeping the bolts loose in Step 1A will make it easier for the Round stretcher to slide into position**
- C. Use eight Bolts (5), eight Spring Washers (3), and eight Flat Washers (2), to loosely attach the center of the Legs (B) to Round Stretcher (C) be sure metal foot plates are facing the bottom of the round support apron (D).  
**TIP: Fully tighten all leg hardware on the Round Support Apron (E) first then fully tighten all leg hardware on the Round Stretcher (D).**

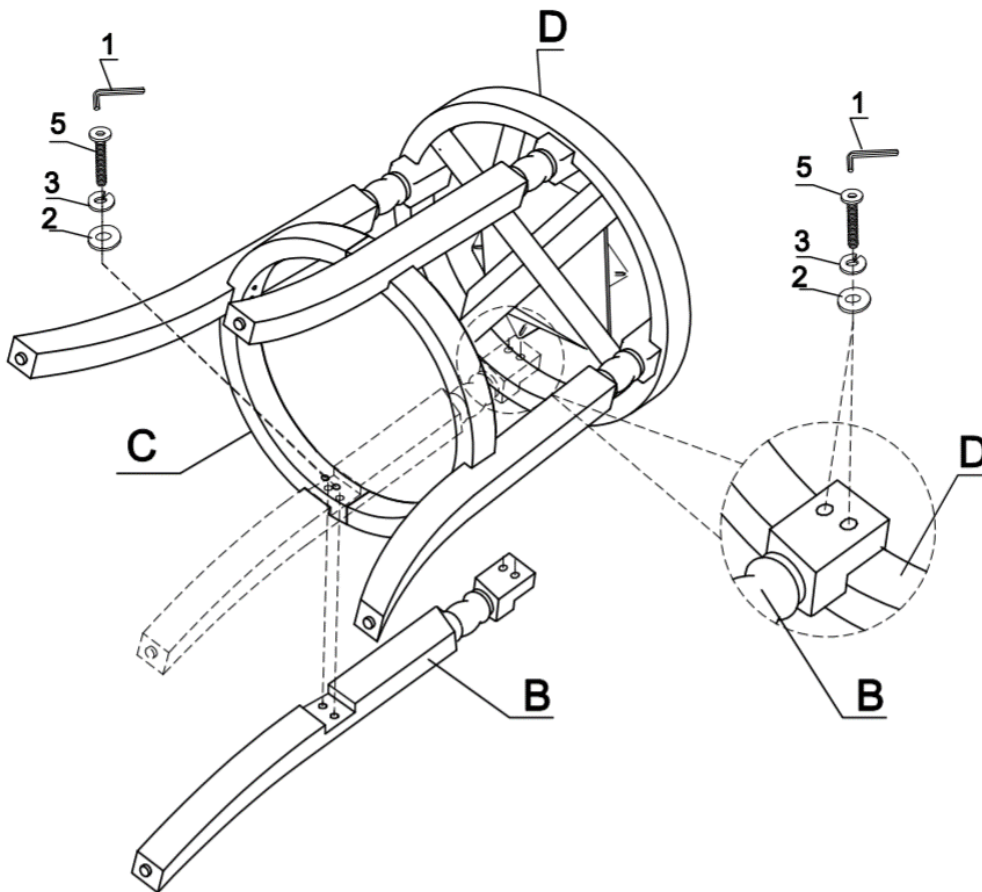

## Step 2

With Seat (A) upside down on a table, use four Bolts (4) four Spring Washers (3), and four Flat Washers (2), to attach Seat (A) to Round Support Apron (D) through the metal plate. Do not tighten bolts fully until all four bolts are lined up.

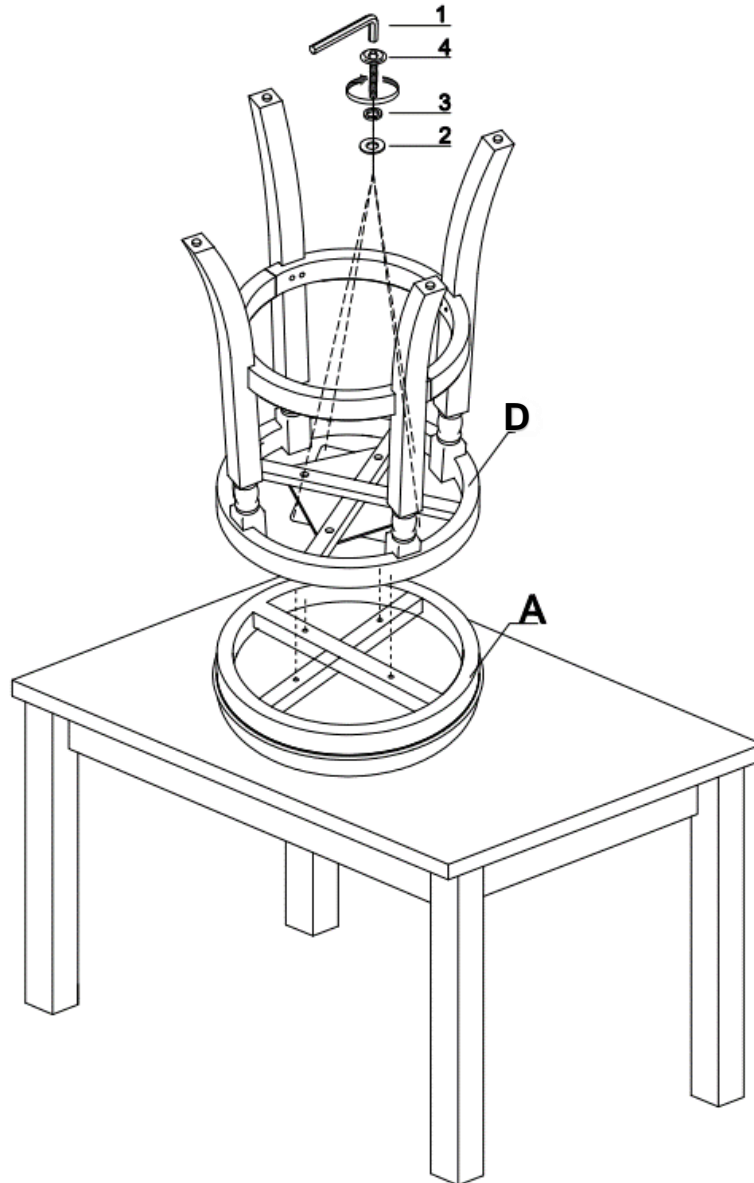

### **Post-Assembly Instructions:**

- Periodically check bolts to be sure they do not loosen over time.
- Do not stand on stool or round stretcher.

### **Furniture Care Tips**

With proper care your furniture will look beautiful for years to come.

#### **Wood Furniture Tips**

- Avoid placing in direct sunlight to keep from fading and discoloring.
- Do not use soap or abrasive cleaners
- Clean up spills as soon as they occur by blotting the food or liquid and then by wiping with a damp cloth
- Vacuum seat cushions periodically to remove dust and dirt
- Use a soft damp cloth to remove normal dust and dirt from the wood,
- Wood furniture should be dusted frequently. Use a lamb's wool duster, microfiber cleaning cloth or cotton cleaning cloth.
- Dusting with a dry cloth can scratch your furniture so lightly spritz your duster with water, a spray duster or wood polish.
- Never spray polish directly on the furniture as it can cause furniture products to buildup.
- Dust in the direction of the grain

#### **Polyester Upholstery Tips**

- Avoid placing in direct sunlight to keep from fading and discoloring.
- Vacuum fabric regularly with an upholstery attachment using low suction.
- Use a soft damp cloth to remove normal dust and dirt
- Wipe up spills immediately, as stains are harder to remove once they are set.
- Most minor stains can be cleaned using 1 tablespoon of dishwashing liquid with 2 cups of cool water. Dab onto the stain with a clean, white cloth. Blot until the liquid is absorbed.
- Never use harsh cleaners.

#### **Bonded Leather Tips**

With proper care your bonded leather furniture will look beautiful for years to come.

- Avoid placing in direct sunlight to keep from fading and discoloring.
- Never use harsh or alcohol-based cleaners.
- Use a soft damp cloth to remove normal dust and dirt and wipe up spills as soon as they occur.
- A good quality leather conditioner may be used periodically following manufacturer's instructions.