

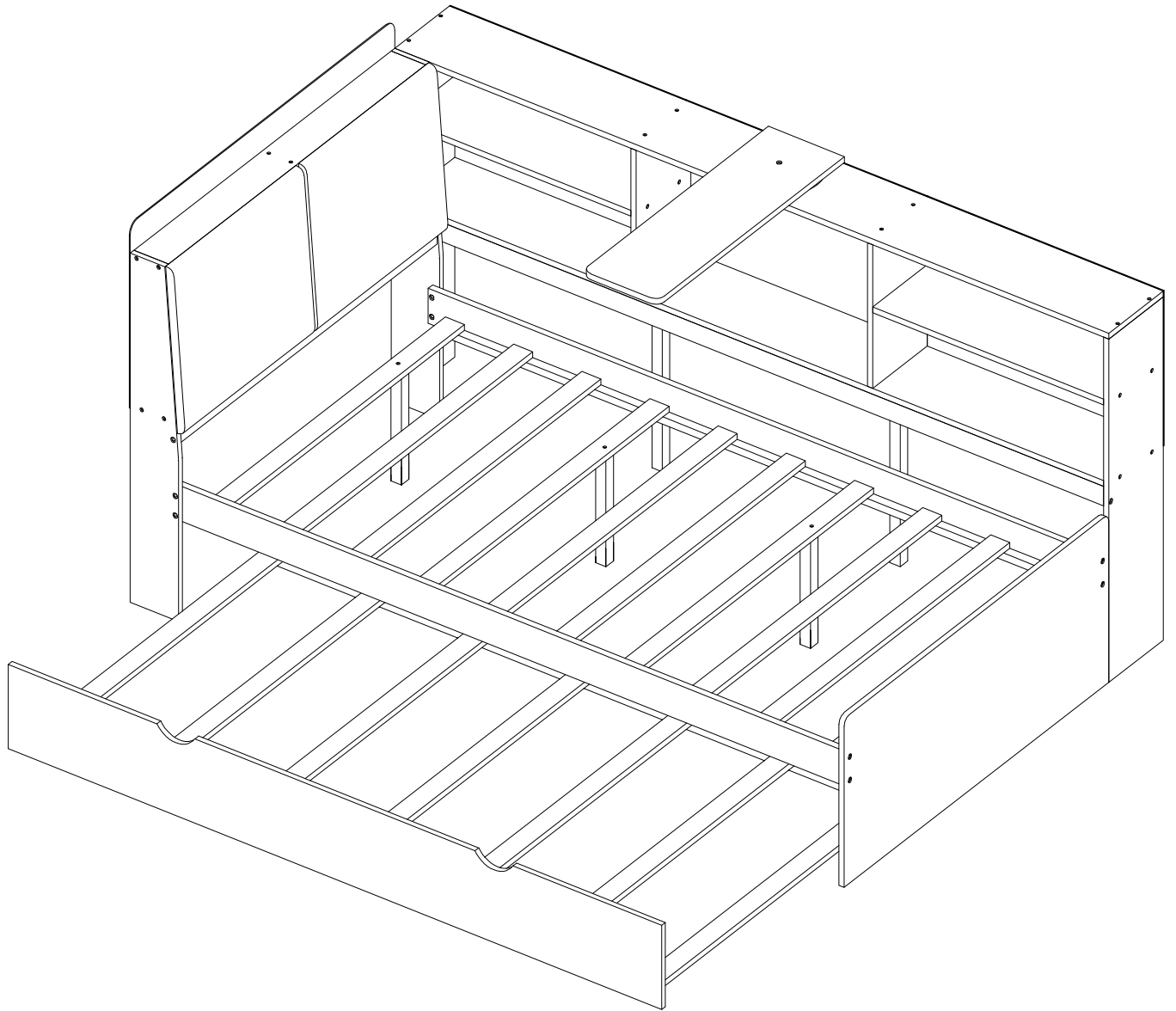

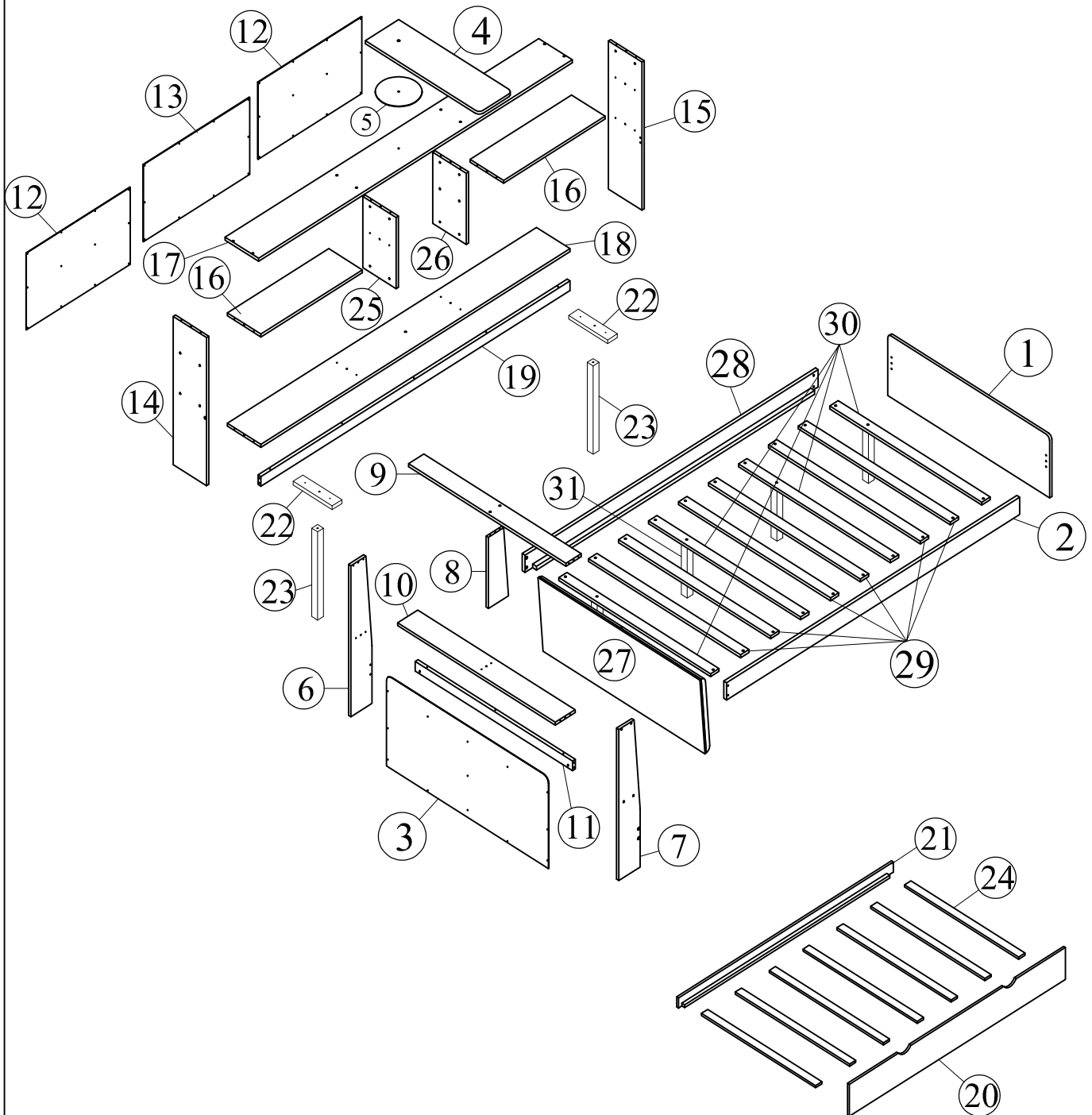





ASSEMBLY INSTRUCTION

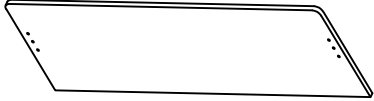
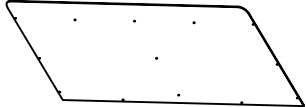

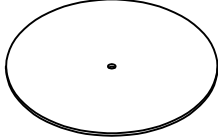
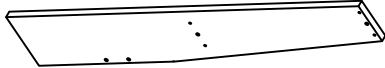
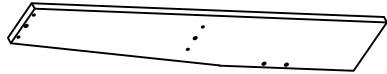

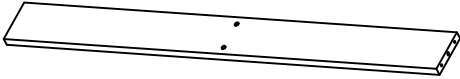
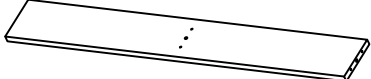
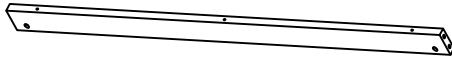
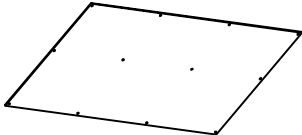
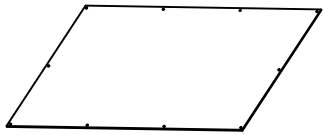
Detail:

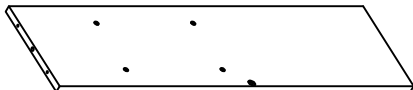

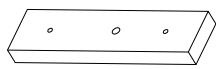

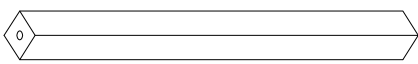
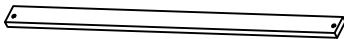
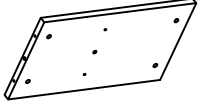
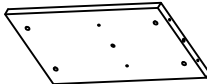

Part List

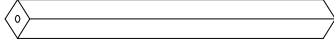
<p>① x1</p>  <p>Panel at Footboard Panneau au pied de lit</p>	<p>③ x1</p>  <p>Panel at Headboard Panel at Headboard</p>
<p>④ x1</p>  <p>Panel Panneau</p>	<p>⑤ x1</p>  <p>Cirde panel Panneau Cirde</p>
<p>⑥ x1</p>  <p>Left panel at side rail Panneau gauche sur le rail latéral</p>	<p>⑦ x1</p>  <p>Right panel at side rail Panneau droit sur le rail latéral</p>
<p>⑧ x1</p>  <p>Bulk head Tête en vrac</p>	<p>⑨ x1</p>  <p>Top wood bar at headboard Barre supérieure en bois à la tête de lit</p>
<p>⑩ x1</p>  <p>Center wood bar of side rail Barre de bois centrale du rail latéral</p>	<p>⑪ x1</p>  <p>Bottom panel at side rail Panneau inférieur au rail latéral</p>
<p>⑫ x2</p>  <p>Back panel of side rail Panneau arrière du rail latéral</p>	<p>⑬ x1</p>  <p>Back panel of side rail Panneau arrière du rail latéral</p>
<p>⑭ x1</p>  <p>Left panel Panneau gauche</p>	<p>⑮ x1</p>  <p>Right panel Panneau droit</p>
<p>⑯ x2</p>  <p>Shelf Étagère</p>	<p>⑳ x2</p>  <p>Wooden support additional legs Pieds supplémentaires de support en bois</p>



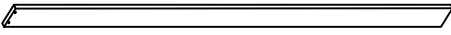
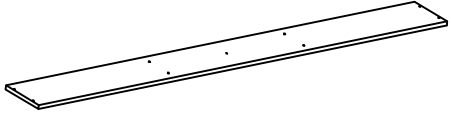



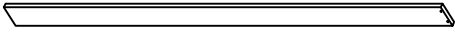
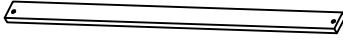
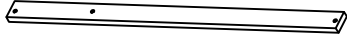

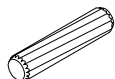

Part List

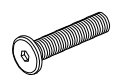
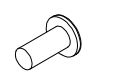
<p>23 x2</p>  <p>Support Leg Jambe de soutien</p>	<p>24 x7</p>  <p>Slats Lattes</p>
<p>25 x1</p>  <p>Left Center panel Panneau central gauche</p>	<p>26 x1</p>  <p>Right center panel Panneau central droit</p>
<p>27 x1</p>  <p>Panel at headboard Panneau à la tête de lit</p>	<p>31 x4</p>  <p>Support Leg Jambe de soutien</p>

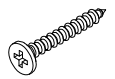
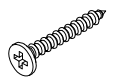
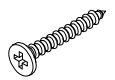
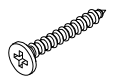
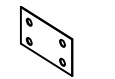
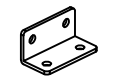
Part List

<p>② x1 </p> <p>Front side rail Rail latéral avant</p>	<p>①7 x1 </p> <p>Top shelf of side rail Tablette supérieure du rail latéral</p>
<p>①8 x1 </p> <p>Bottom shelf of side rail Tablette inférieure du rail latéral</p>	<p>①9 x1 </p> <p>Wood bar at side rail Barre en bois sur le rail latéral</p>
<p>②0 x1 </p> <p>Front trundle Lit gigogne avant</p>	<p>②1 x1 </p> <p>Back trundle Lit gigogne arrière</p>
<p>②8 x1 </p> <p>Back side rail Rail latéral arrière</p>	<p>②9 x6 </p> <p>Slats Lattes</p>
<p>③0 x4 </p> <p>Slats Lattes</p>	

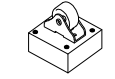

Hardware List

No/Non	OUTLOO/PERSPECTIVES	DESC/DESC	QTY/Qt é
(A)		Dowel Ø8*30mm Cheville Ø8*30mm	24pcs 24 pièces
(B)		Bolts M6*60mm Boulons M6*60mm	8pcs 8pièces
(C)		Bolts M6*20mm Boulons M6*20mm	5pcs 5pièces
(D)		Bolts M6*15mm Boulons M6*15mm	5pcs 5pièces
(E)		Cross dowel M6*13mm Cheville croisée M6*13mm	8pcs 8pièces
(F)		Cross dowel Ø10*10mm Cheville croisée Ø10*10mm	36pcs 36pièces
(G)		Flat head screw #8*60mm Vis à tête plate #8*60mm	36pcs 36pièces
(H)		Flat head screw #8*50mm Vis à tête plate #8*50mm	8pcs 8pièces
(I)		Flat head screw #8*30mm Vis à tête plate #8*30mm	58pcs 58pièces
(J)		Flat head screw #7*12mm Vis à tête plate #7*12mm	38pcs 38pièces
(K)		Metal Rectangle Rectangle en métal	1pc 1pièce
(L)		Pas L Pas L	6pcs 6pièces
(M)		Flap fitting (Left) Ferrure d' abattant (Gauche)	1pc 1pièce
(N)		Flap fitting (Right) Ferrure de volet (Droite)	1pc 1pièce
(O)		Door Hinge Charnière de porte	3pcs 3pièces
(P)		Wheels roues	4pcs 4pièces
(Q)		Allen key 60*22*4mm Clé Allen 60*22*4mm	1pc 1pièce
(X)		Round head screw #8*15mm Vis à tête ronde #8*15mm	47pcs 47pièces

ASSEMBLY TOOLS REQUIRED (NOT INCLUDED)/OUTILS D'ASSEMBLAGE REQUIS (NON INCLUS)

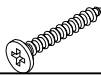
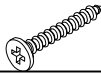
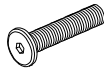

Hardware List



No/Non	OUTL00/PERSPECTIVES	DESC/DESC	QTY/Qt é
(Y)		Inhaler magnet Aimant pour inhalateur	2pcs 2 pièces
(T)		Flat head screw #7*15mm Vis à tête plate #7*15mm	4pcs 4pièces
(W)		Flat head screw #6*15mm Vis à tête plate #6*15mm	12pcs 12pièces
(Z)		Bolts M6*30mm Boulons M6*30mm	6pcs 6pièces
(A1)		Wood bar Barre en bois	2pcs 2pièces

ASSEMBLY TOOLS REQUIRED (NOT INCLUDED)/OUTILS D'ASSEMBLAGE REQUIS (NON INCLUS)



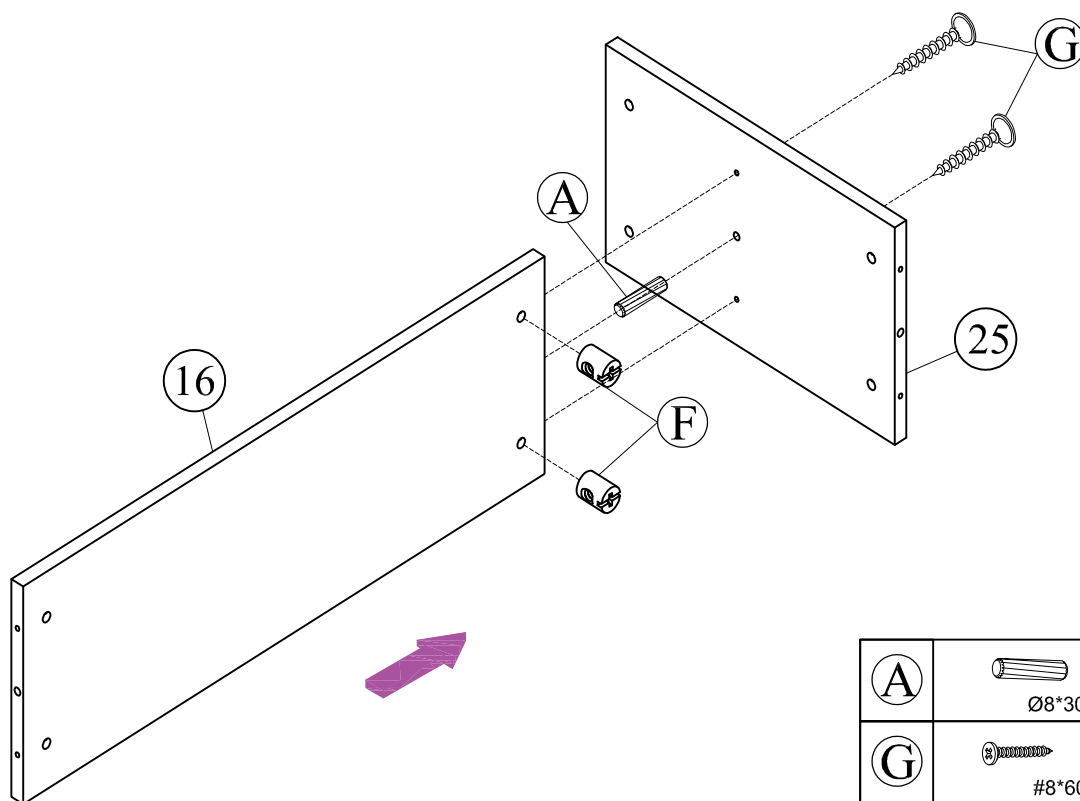



STEP 1:

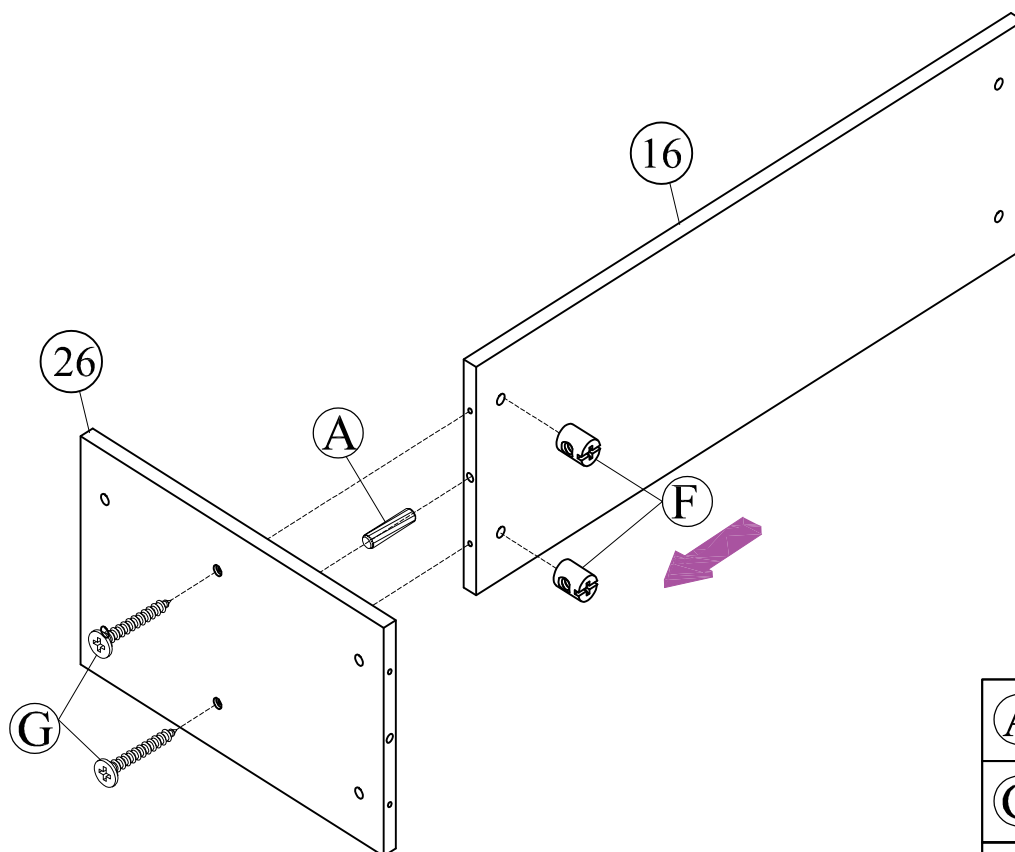

A	 Ø8*30mm	1pc 1pièce
G	 #8*60mm	2pcs 2pièces
F	 Ø10*10mm	2pcs 2pièces



STEP 2:



A	 Ø8*30mm	1pc 1pièce
G	 #8*60mm	2pcs 2pièces
F	 Ø10*10mm	2pcs 2pièces

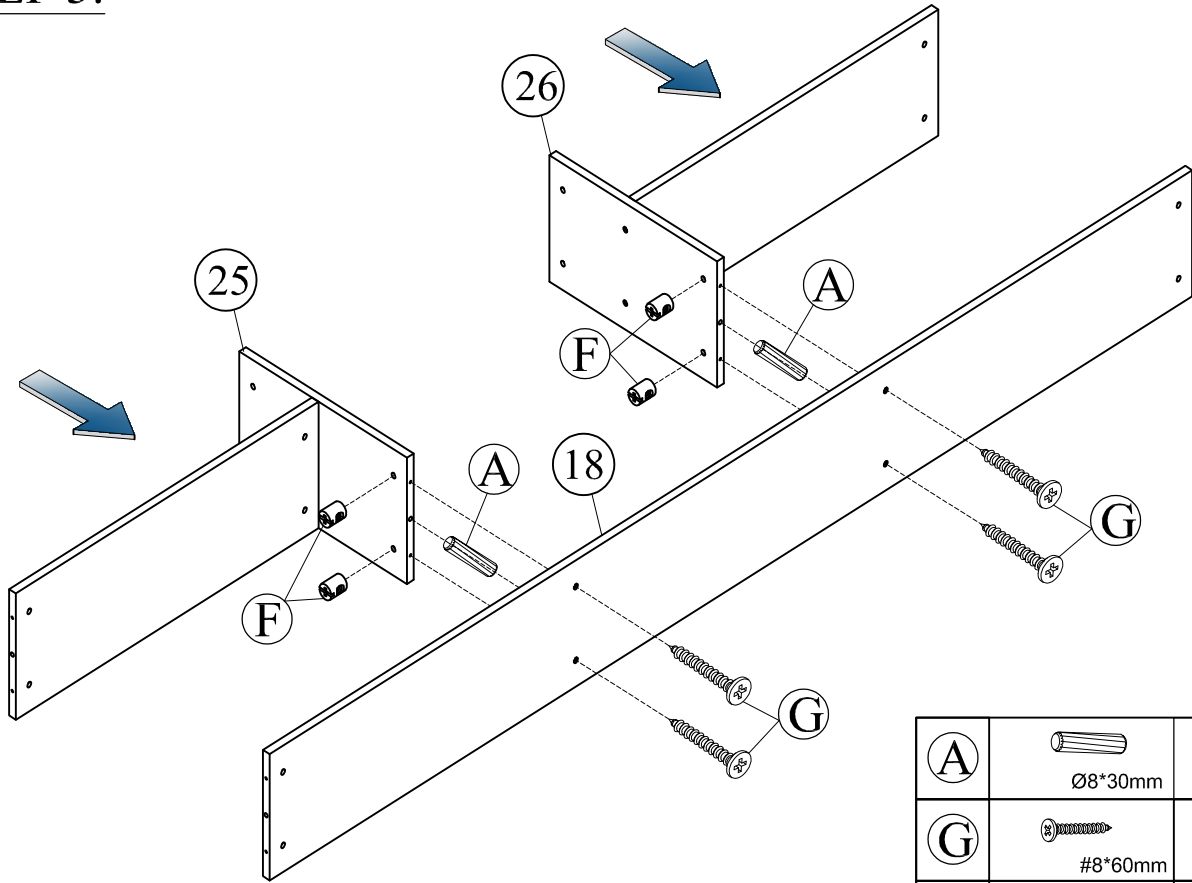

STEP 3:



(A)		2pcs 2pièces
(G)		4pcs 4pièces
(F)		4pcs 4pièces

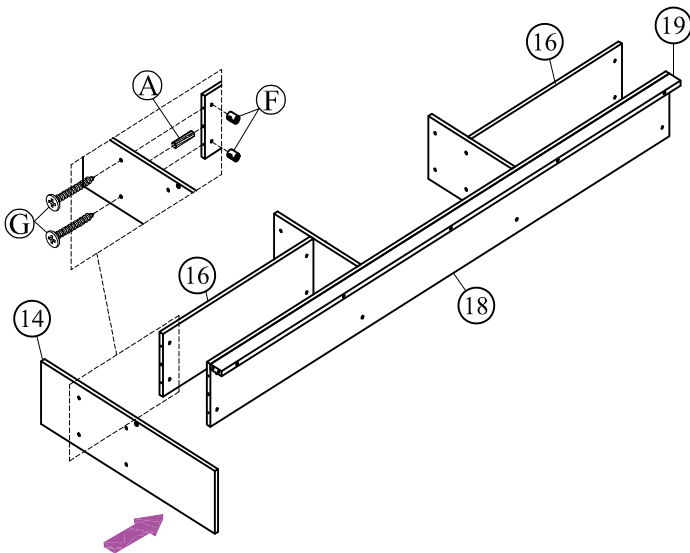





STEP 4.1:

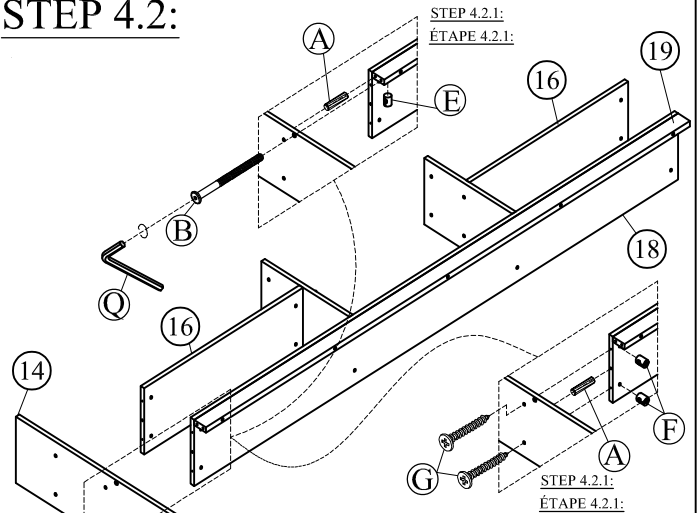

(A)		1pc 1pièces
(G)		2pcs 2pièces
(F)		2pcs 2pièces



STEP 4.2:



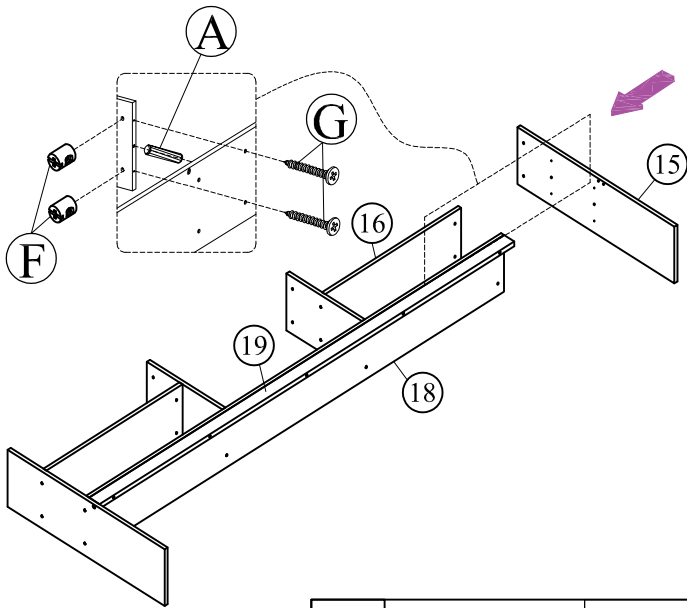

(G)		2pcs 2pièces
(F)		2pcs 2pièces
(A)		2pcs 2pièces
(E)		1pc 1pièce
(B)		1pc 1pièce
(Q)		1pc 1pièce

STEP 5.1:





(A)	 Ø8*30mm	1pc 1pièce
(G)	 #8*60mm	2pcs 2pièces
(F)	 Ø10*10mm	2pcs 2pièces

STEP 5.2:

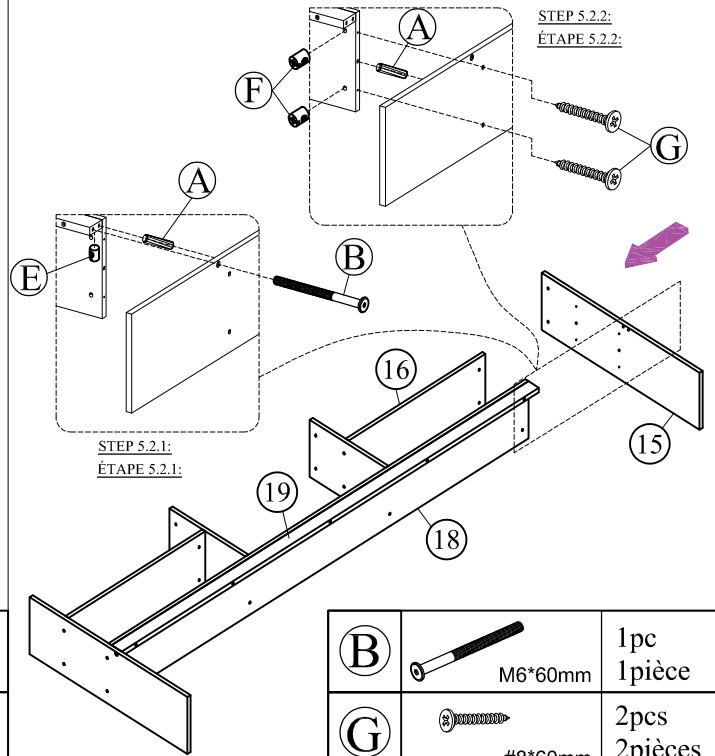
(E)	 M6*13mm	1pc 1pièce
(A)	 Ø8*30mm	2pcs 2pièces



(B)	 M6*60mm	1pc 1pièce
(G)	 #8*60mm	2pcs 2pièces
(F)	 Ø10*10mm	2pcs 2pièces

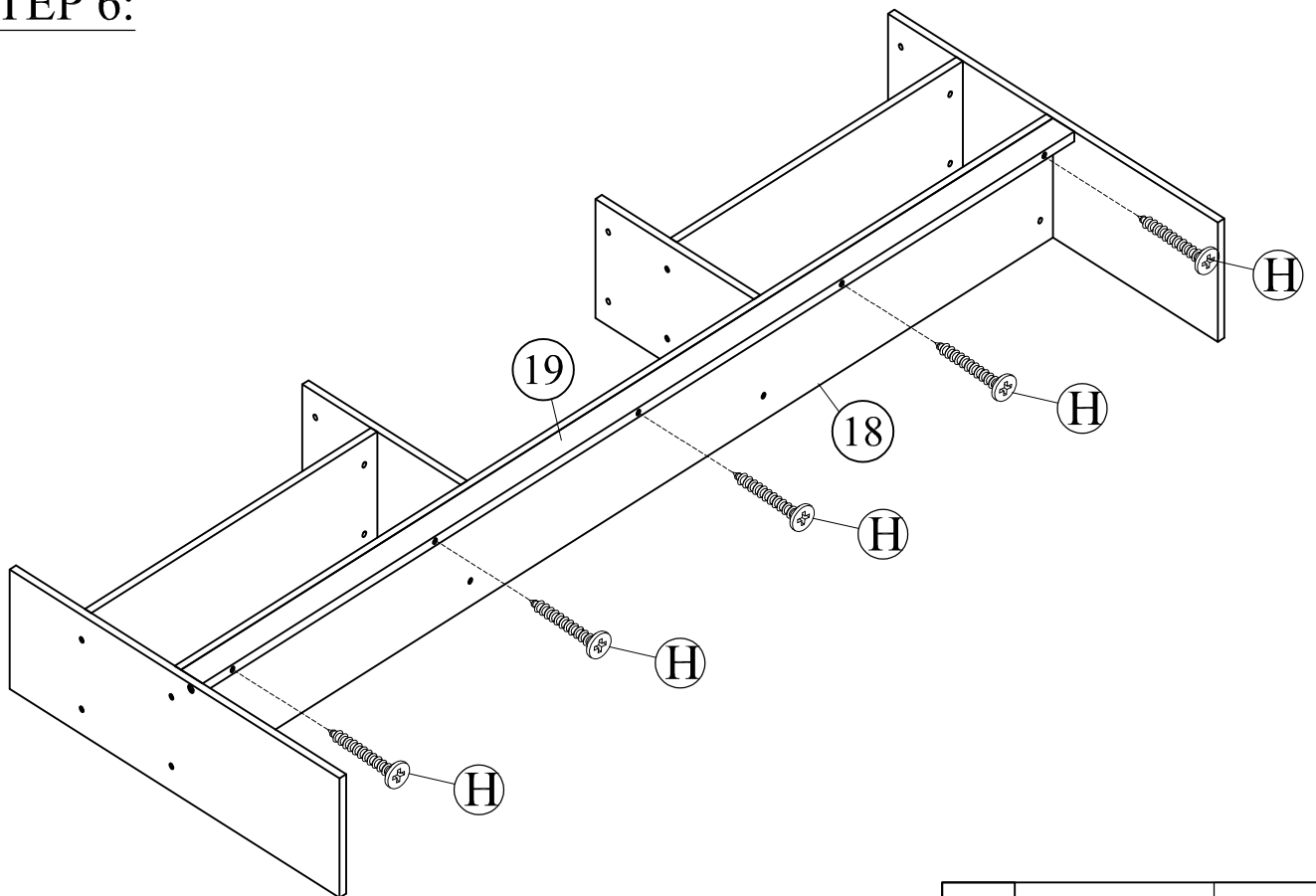

STEP 6:



(H)	 #8*50mm	5pcs 5pièces
-----	---	-----------------

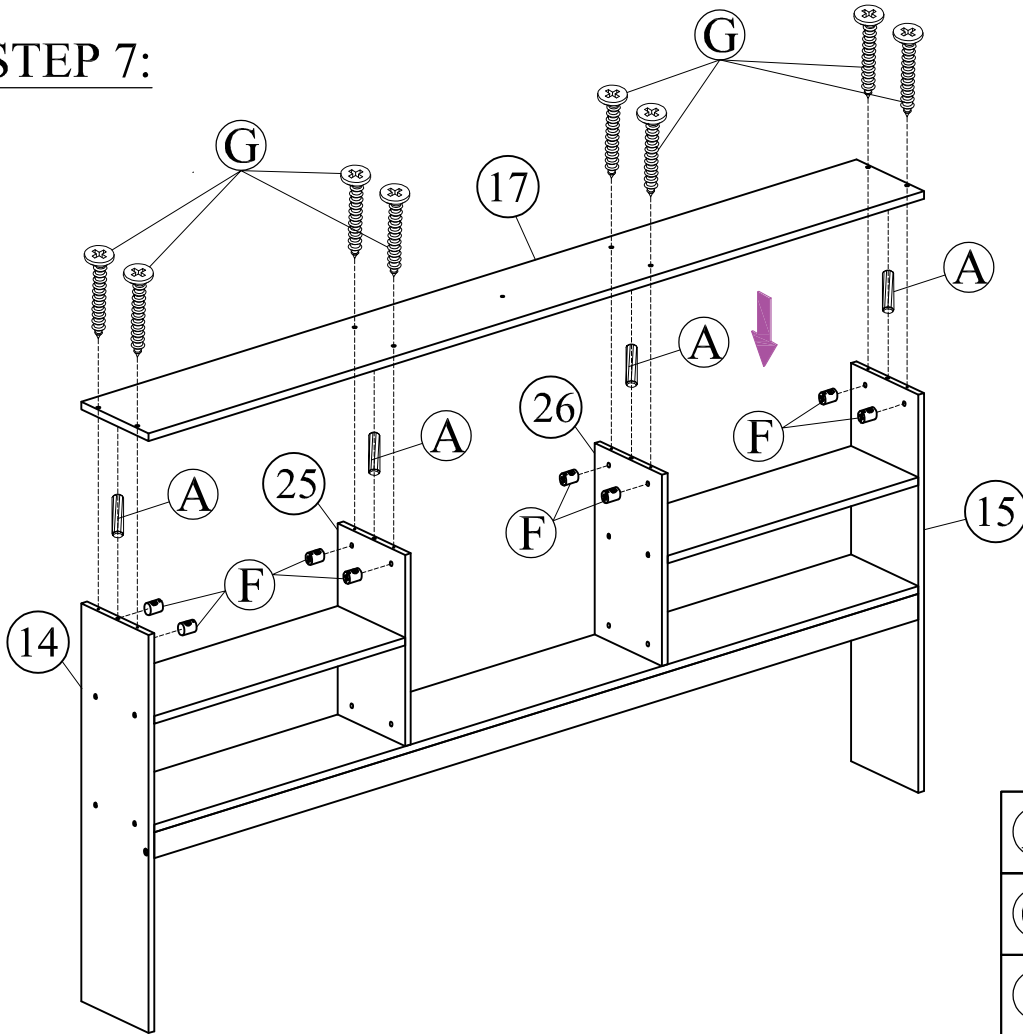

STEP 7:

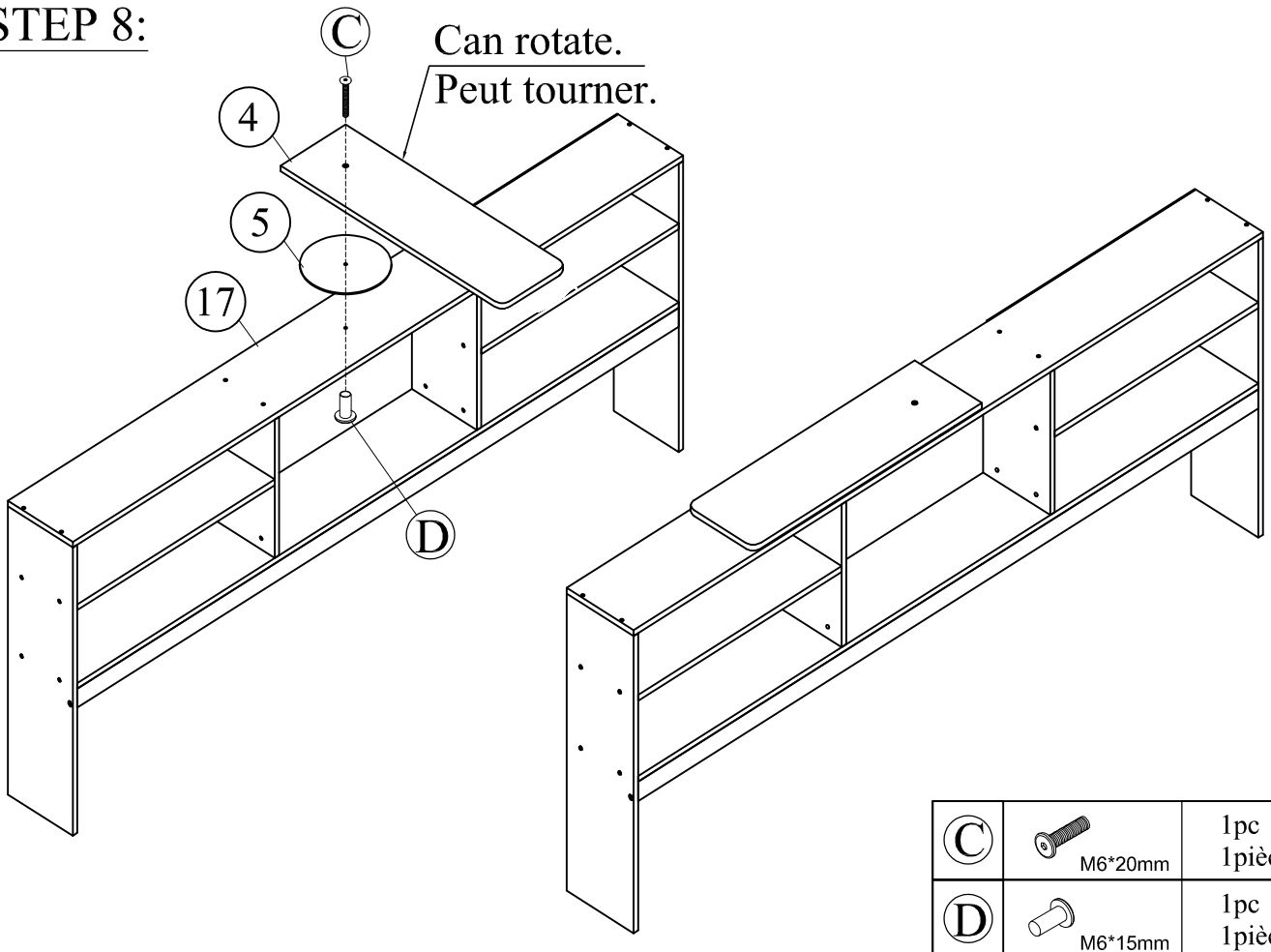

(A)	 Ø8*30mm	4pcs 4pièces
(G)	 #8*60mm	8pcs 8pièces
(F)	 Ø10*10mm	8pcs 8pièces

STEP 8:



(C)	 M6*20mm	1pc 1pièce
(D)	 M6*15mm	1pc 1pièce

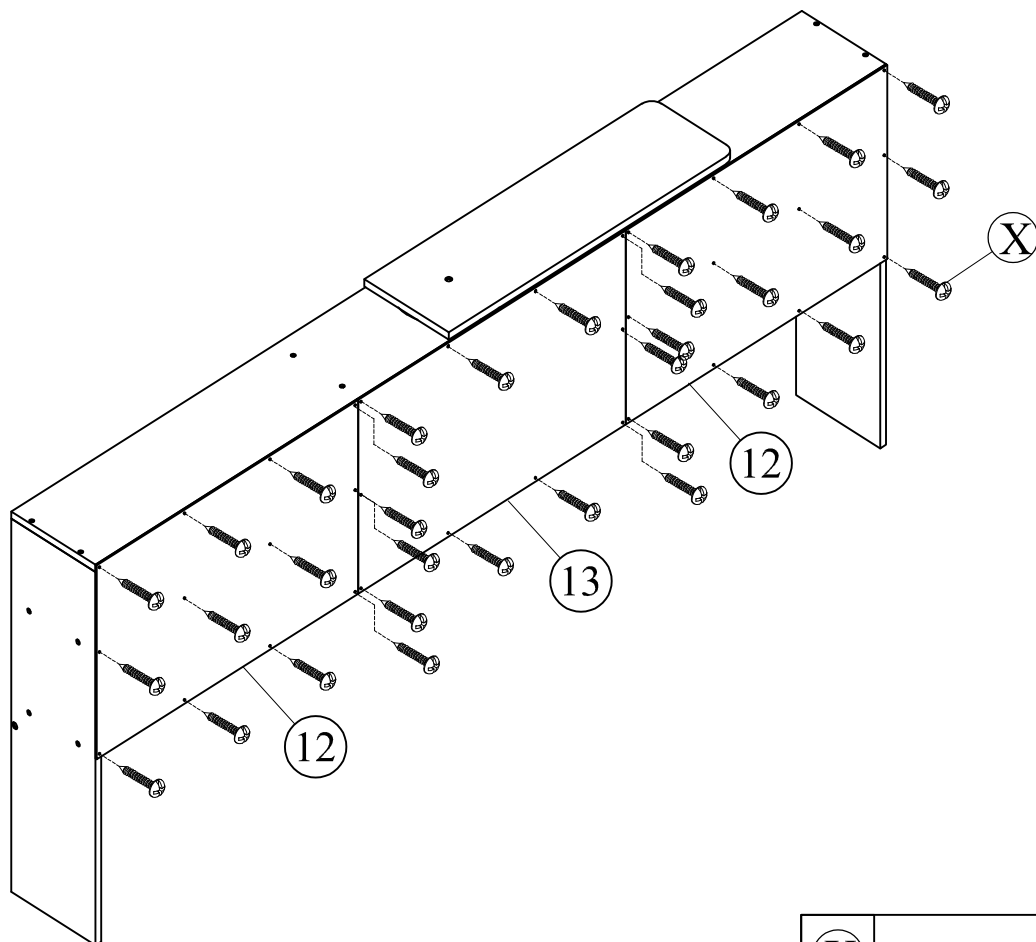

STEP 9:

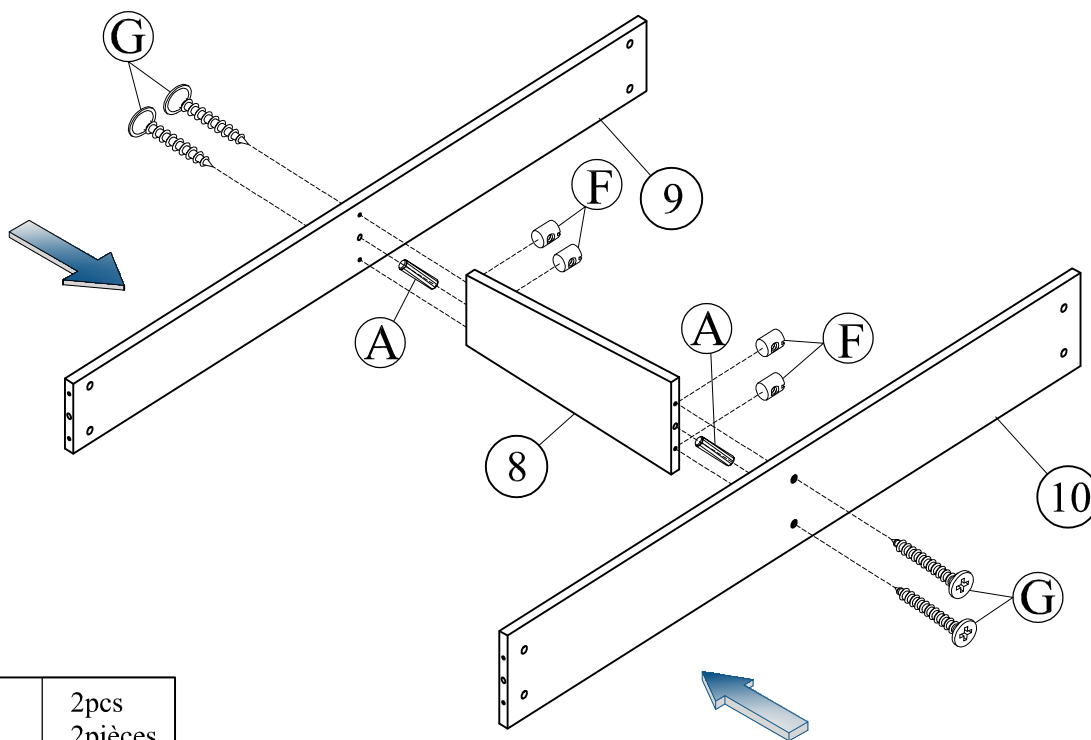

(X)		34pcs 34pièces
	#8*15mm	

STEP 10:



(A)		2pcs 2pièces
	Ø8*30mm	
(G)		4pcs 4pièces
	#8*60mm	
(F)		4pcs 4pièces
	Ø10*10mm	

STEP 11.1:

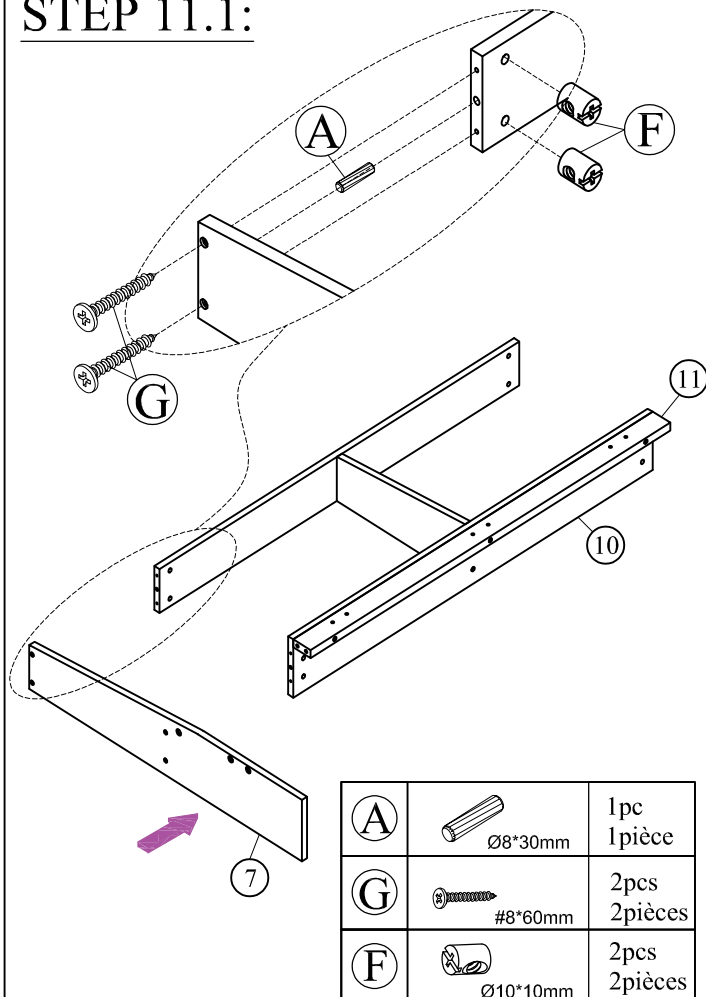

A		1pc 1pièce
G		2pcs 2pièces
F		2pcs 2pièces

STEP 11.2:

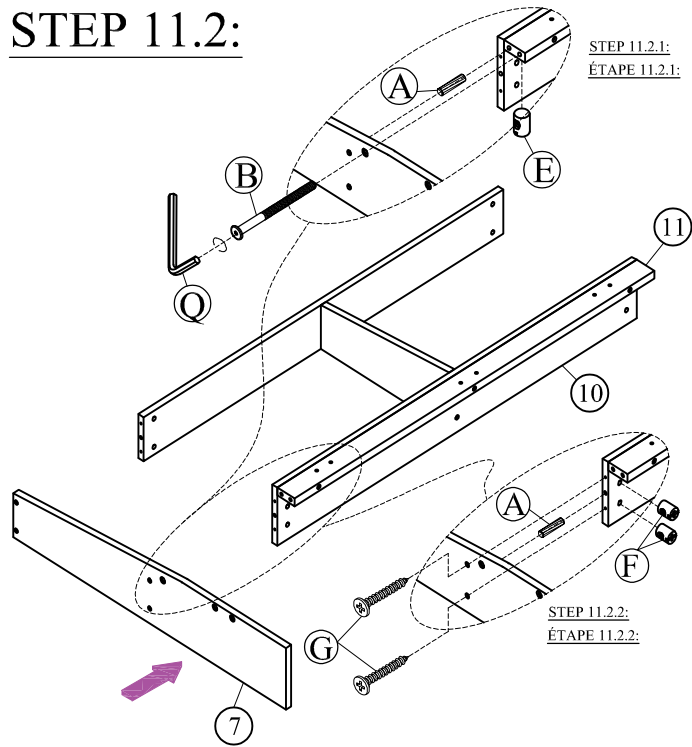

STEP 11.2.1:
ÉTAPE 11.2.1:

STEP 11.2.2:
ÉTAPE 11.2.2:

Q		1pc 1pièce	A		2pcs 2pièces
E		1pc 1pièce	G		2pcs 2pièces
B		1pc 1pièce	F		2pcs 2pièces

STEP 12.1:

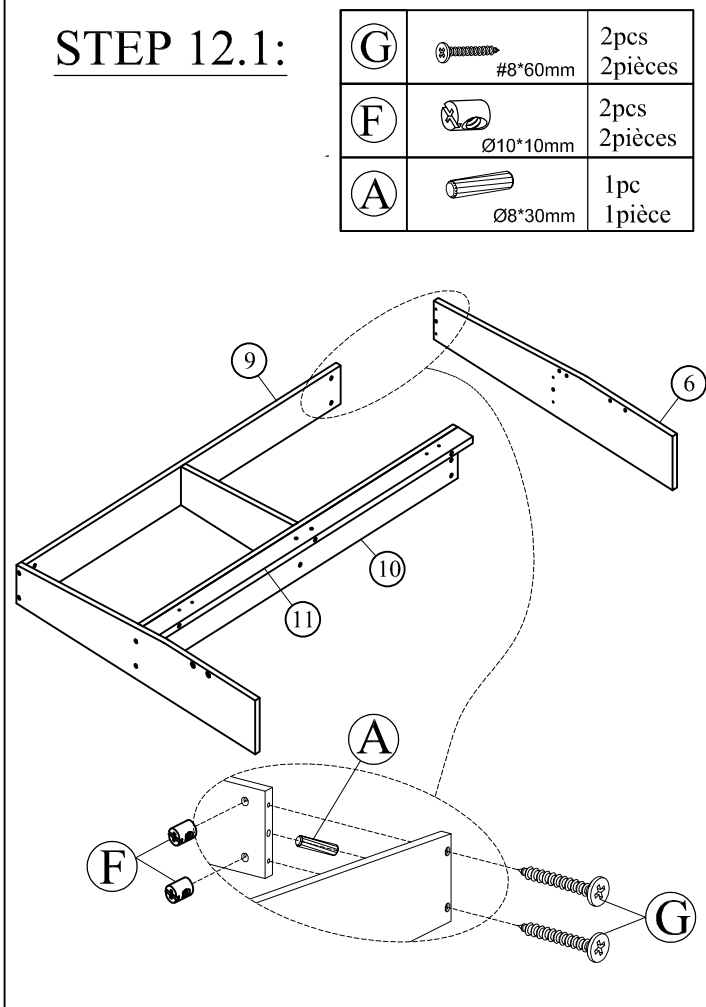

G		2pcs 2pièces
F		2pcs 2pièces
A		1pc 1pièce

STEP 12.2:

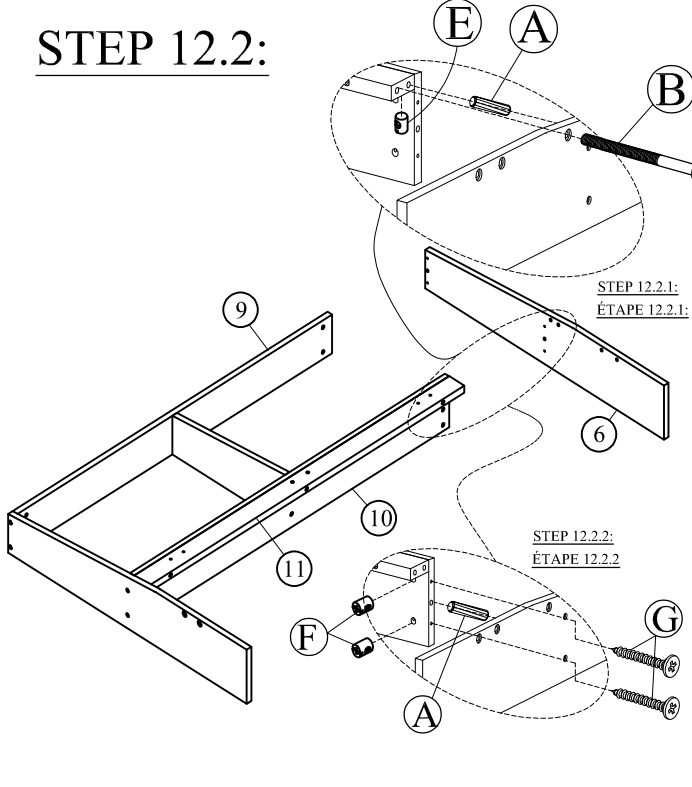

STEP 12.2.1:
ÉTAPE 12.2.1:

STEP 12.2.2:
ÉTAPE 12.2.2:

E		1pc 1pièce	G		2pcs 2pièces
B		1pc 1pièce	F		2pcs 2pièces
A		2pcs 2pièces			

STEP 13:

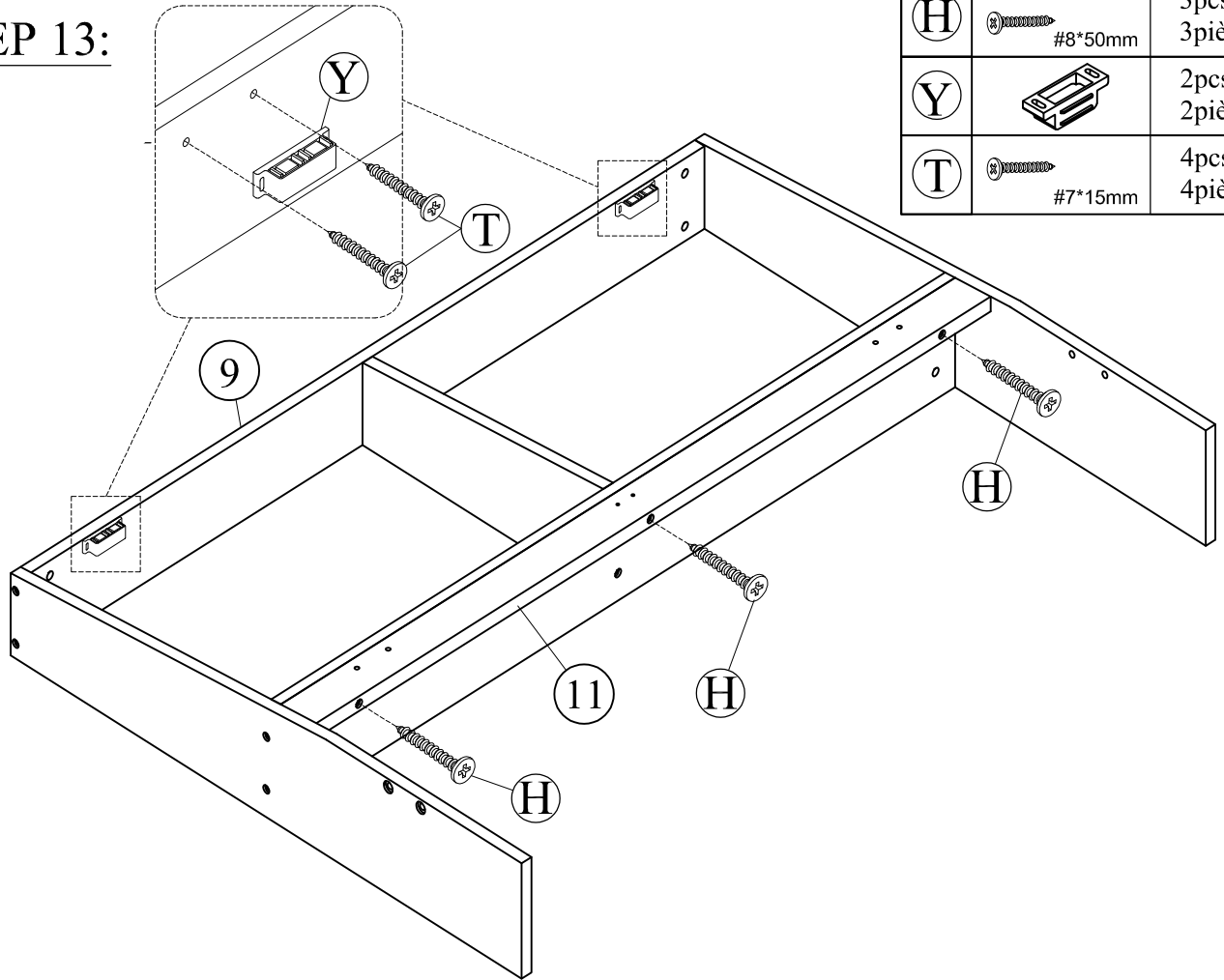

(H)	#8*50mm	3pcs 3pièces
(Y)		2pcs 2pièces
(T)	#7*15mm	4pcs 4pièces

STEP 14:

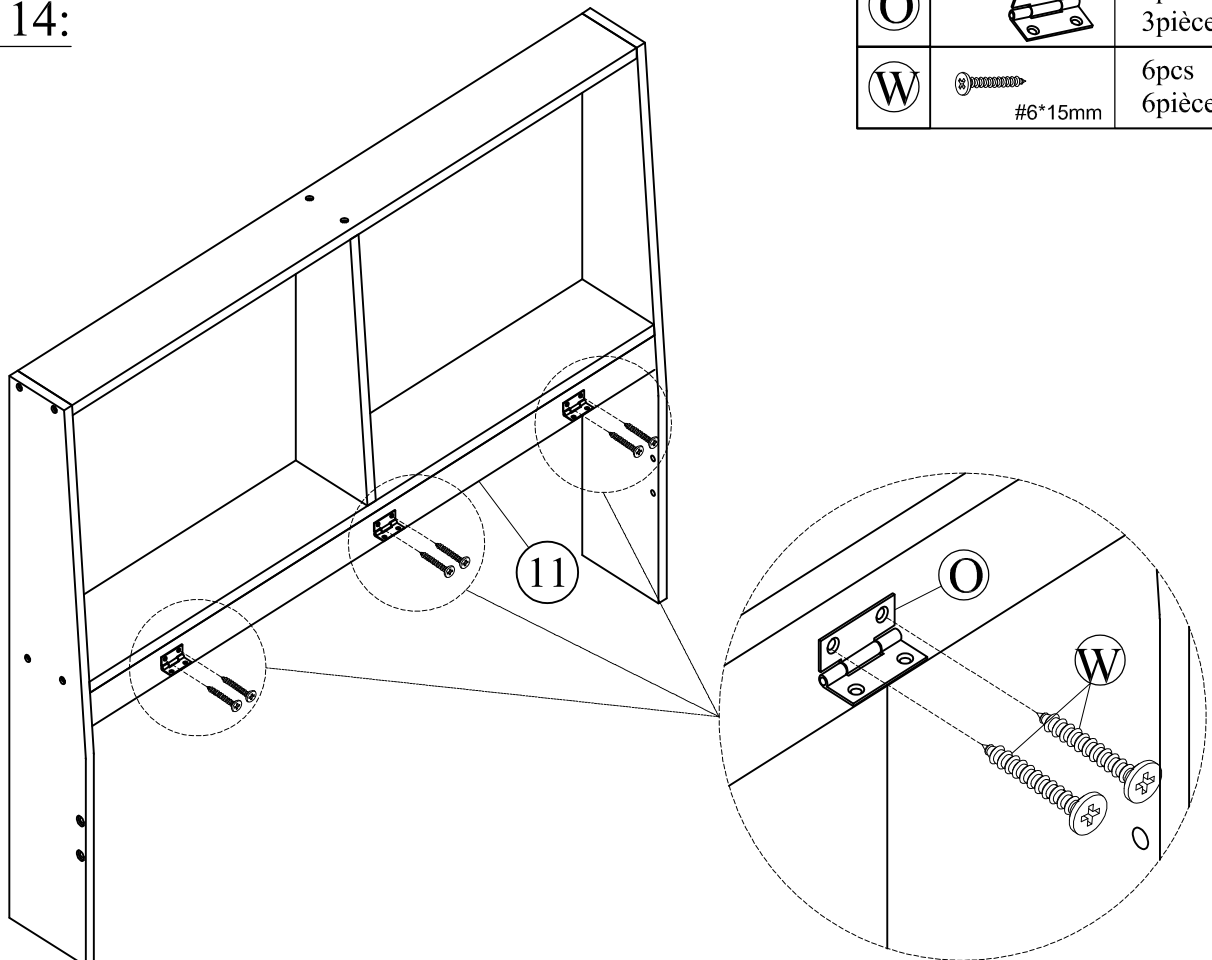

(O)		3pcs 3pièces
(W)	#6*15mm	6pcs 6pièces

STEP 15:

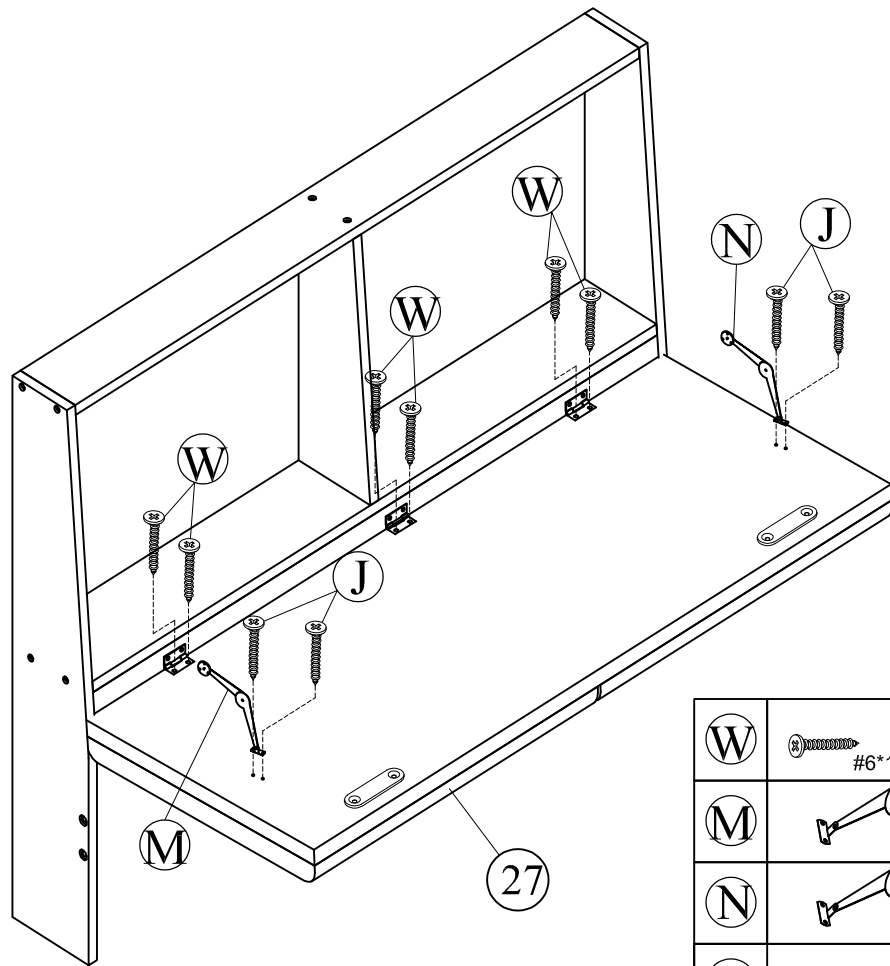

W	#6*15mm	6pcs 6pièces
M		1pc 1pièce
N		1pc 1pièce
J	#7*12mm	4pcs 4pièces

STEP 16:

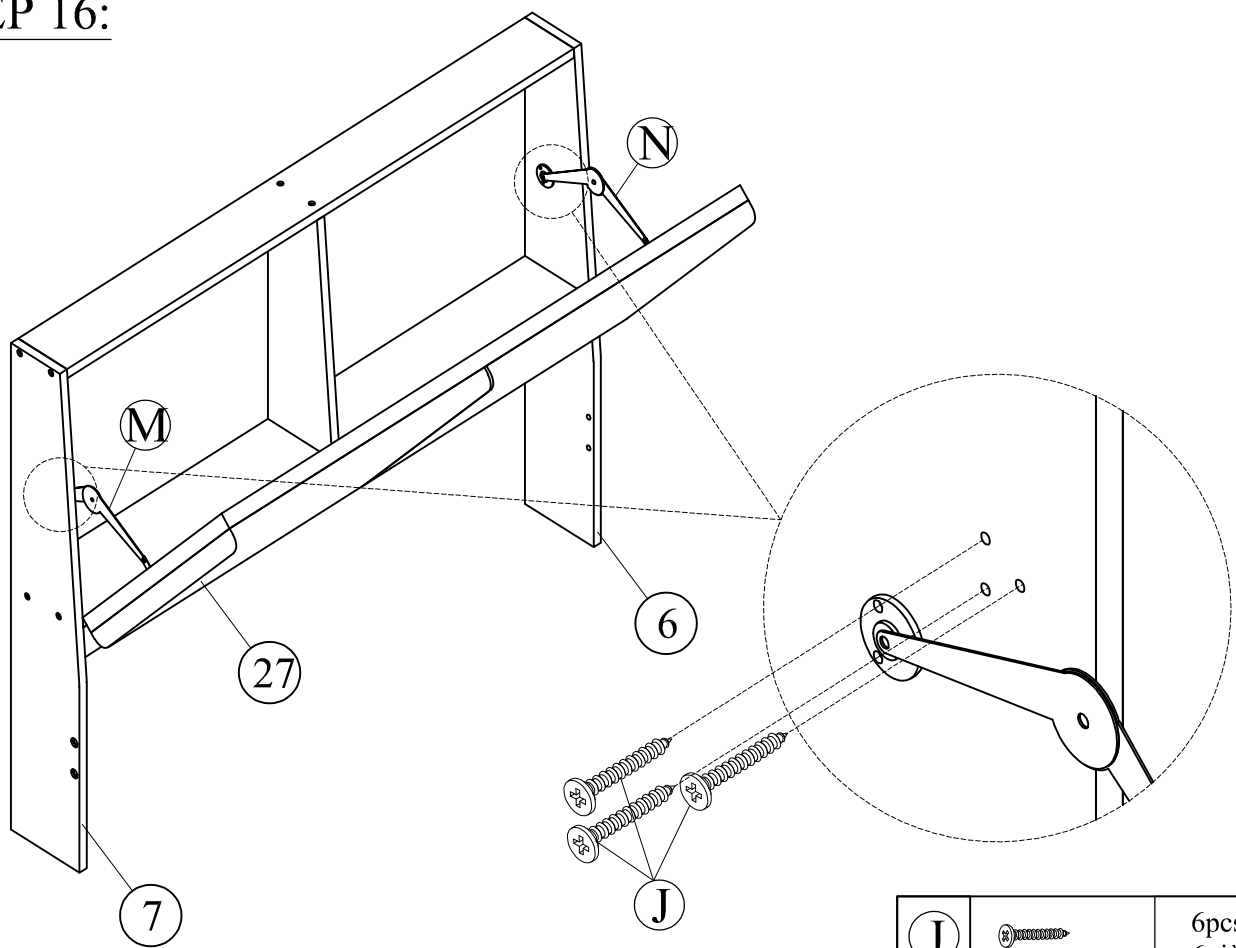

J	#7*12mm	6pcs 6pièces
---	---------	-----------------



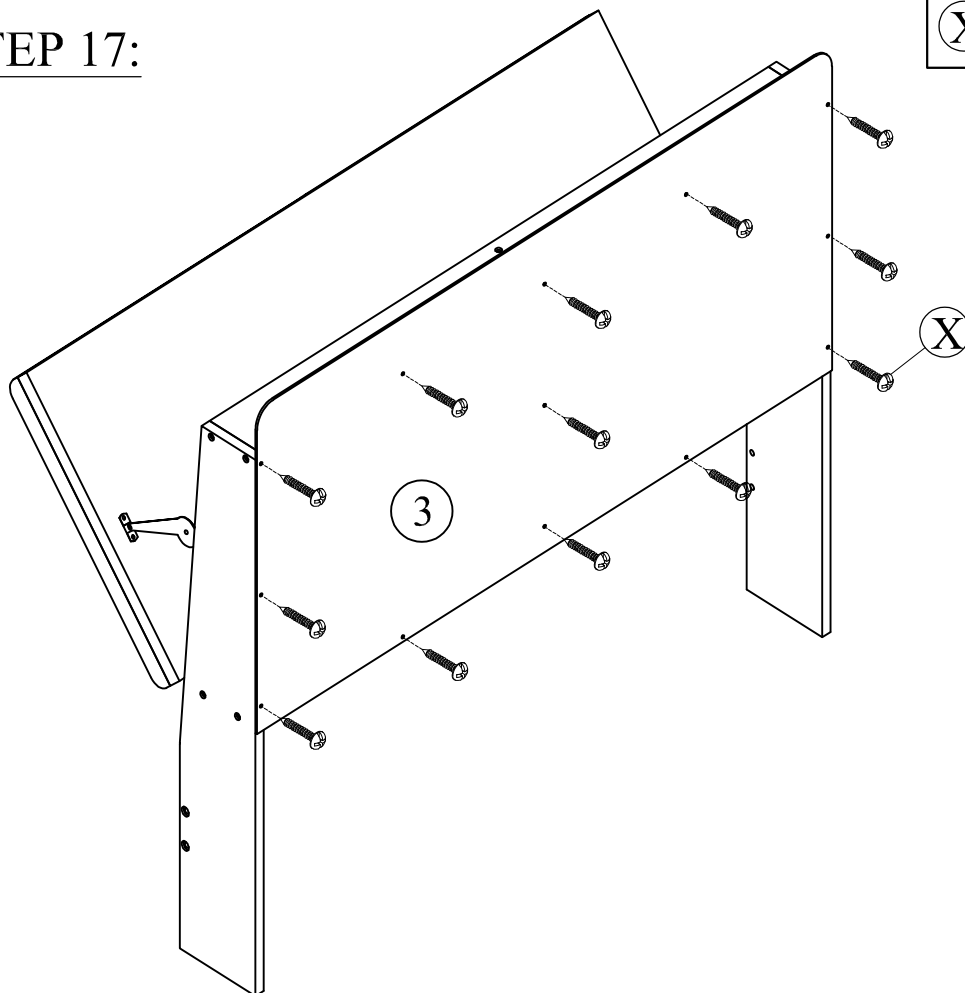

STEP 17:

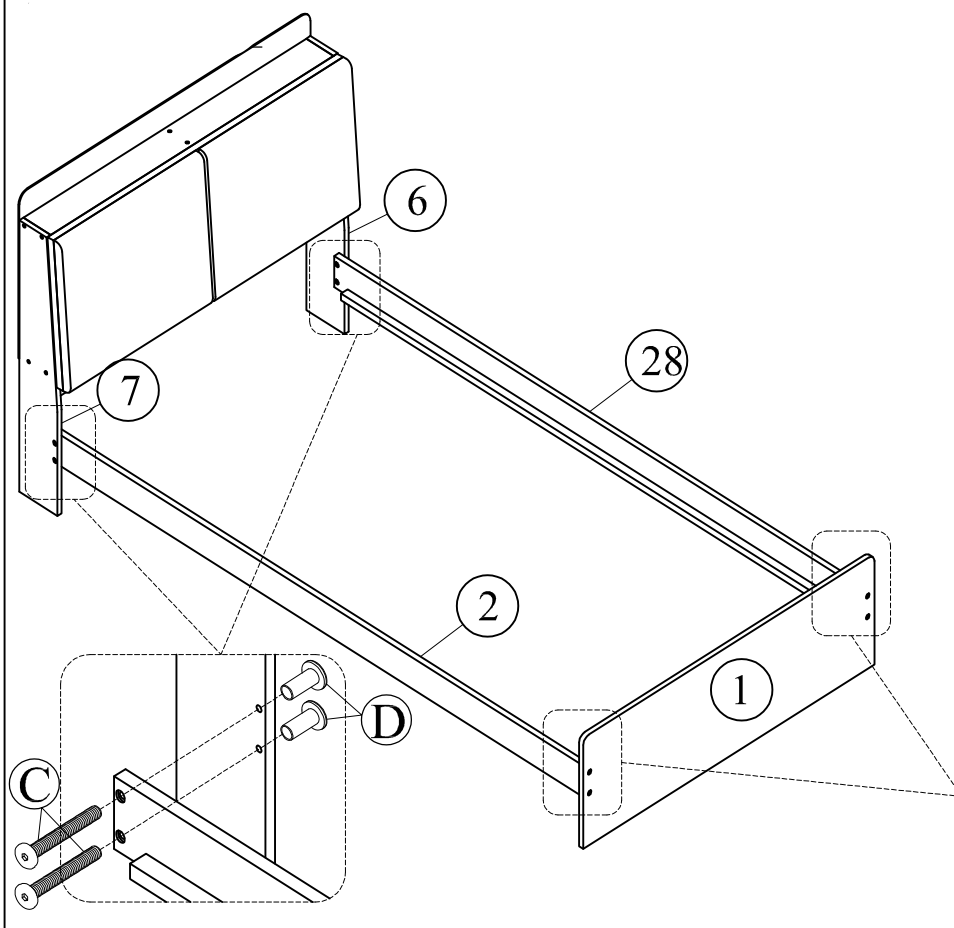

(X)	 #8*15mm	13pcs 13pièces
-----	--	-------------------



STEP 18:

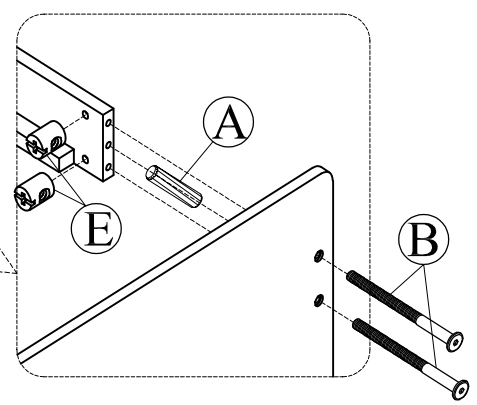

(C)	 M6*20mm	4pcs 4pièces
(D)	 M6*15mm	4pcs 4pièces
(E)	 M6*13mm	4pcs 4pièces
(B)	 M6*60mm	4pcs 4pièces
(A)	 Ø8*30mm	2pcs 2pièces



STEP 19:

I	 #8*30mm	20pcs 20pièces
Z	 M6*30mm	4pcs 4pièces
Q		1pc 1pièce

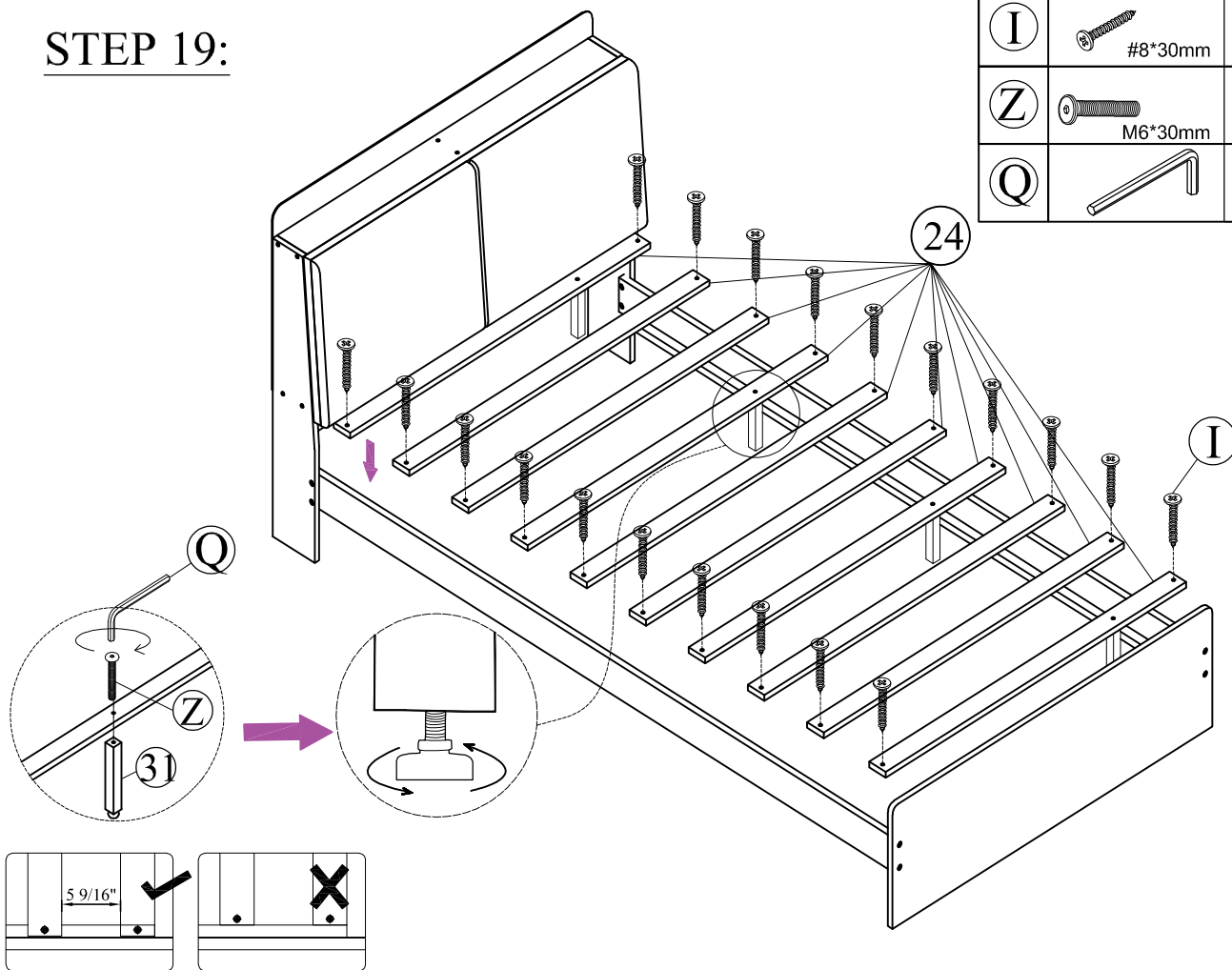

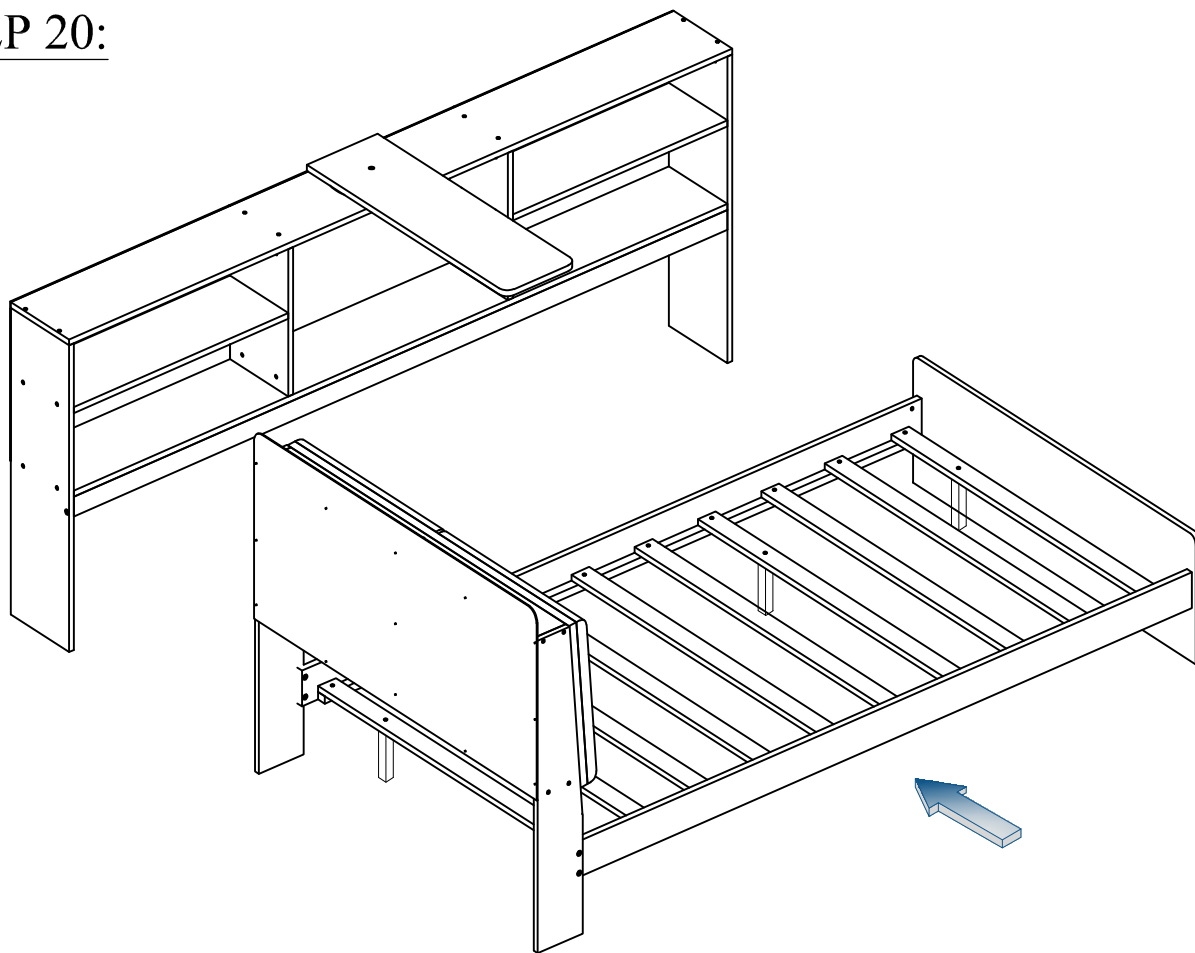

STEP 20:



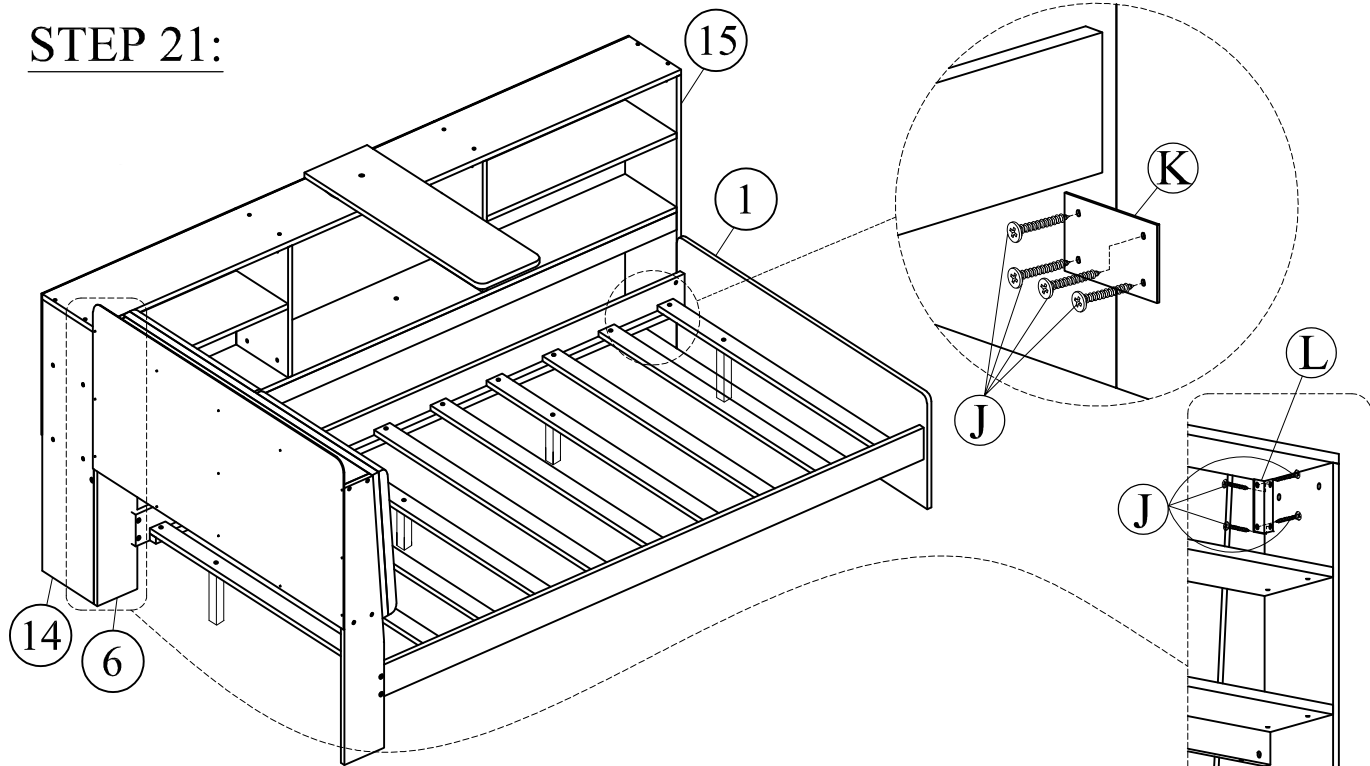

STEP 21:

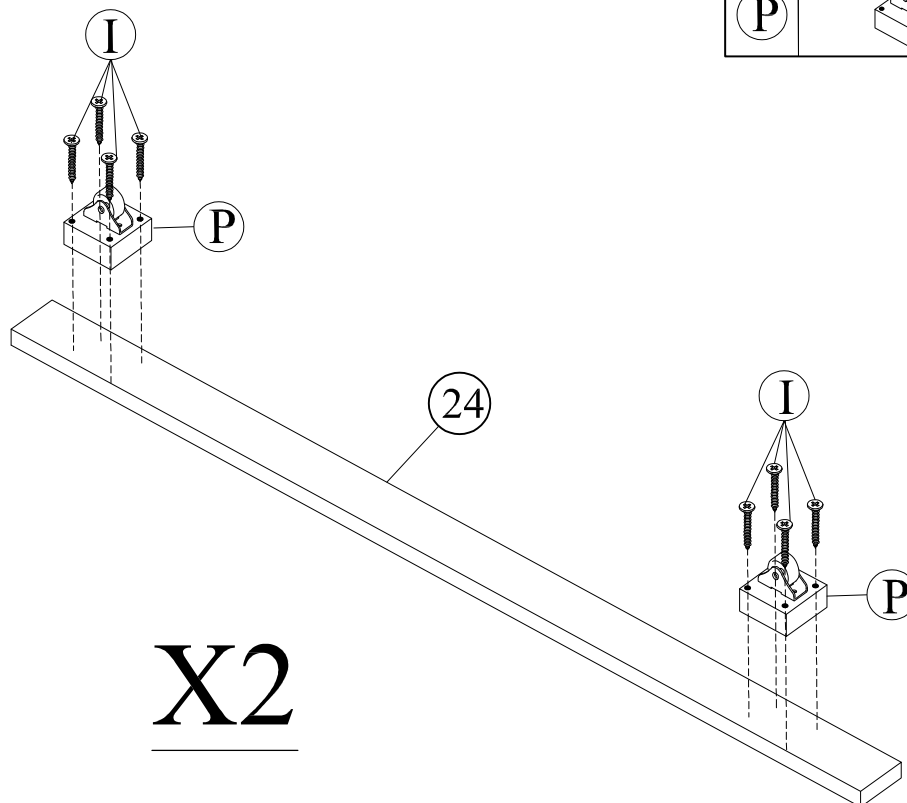

K		1pc 1pièce
J	 #7*15mm	12pcs 12pièces
L		2pcs 2pièces

STEP 22:



I	 #8*30mm	16pcs 16pièces
P		4pcs 4pièces

X2

STEP 23:

I	 #8*30mm	14pcs 14pièces
---	---	-------------------

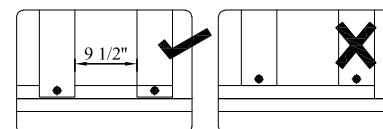
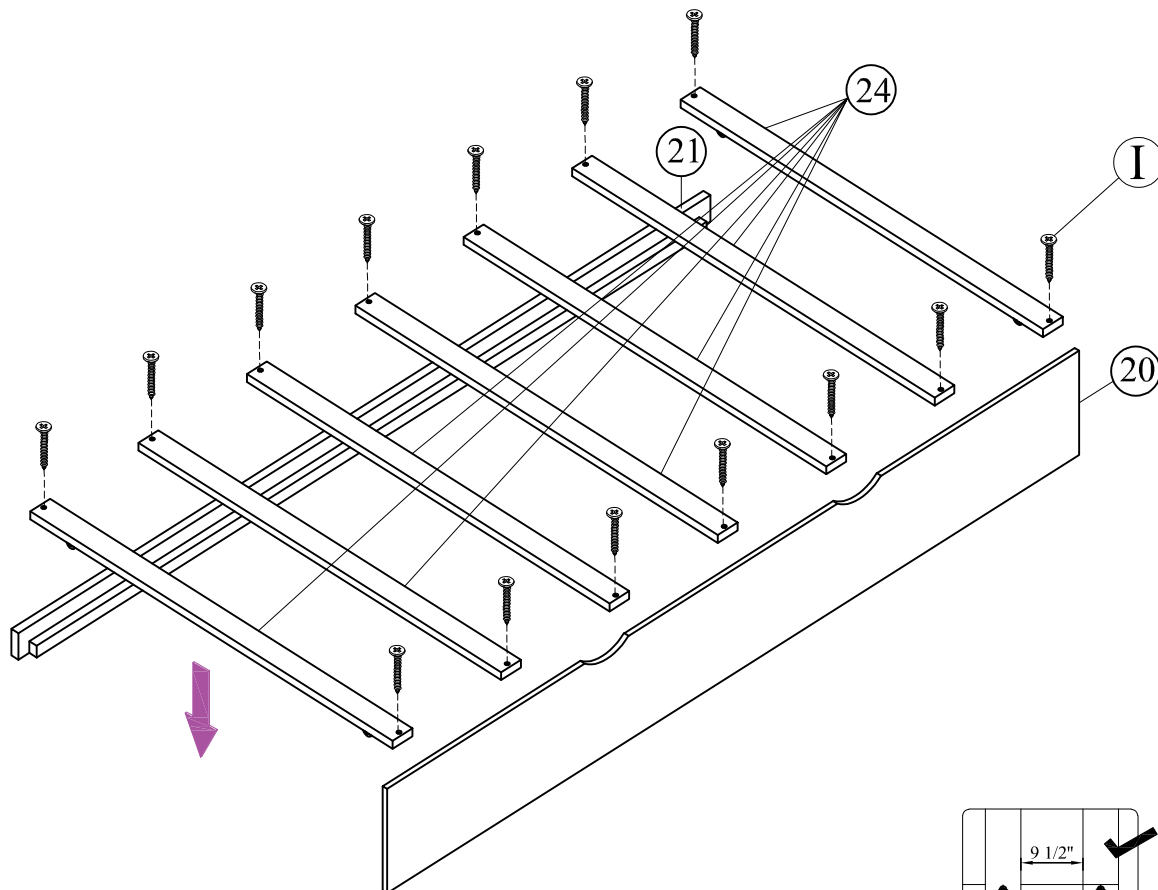

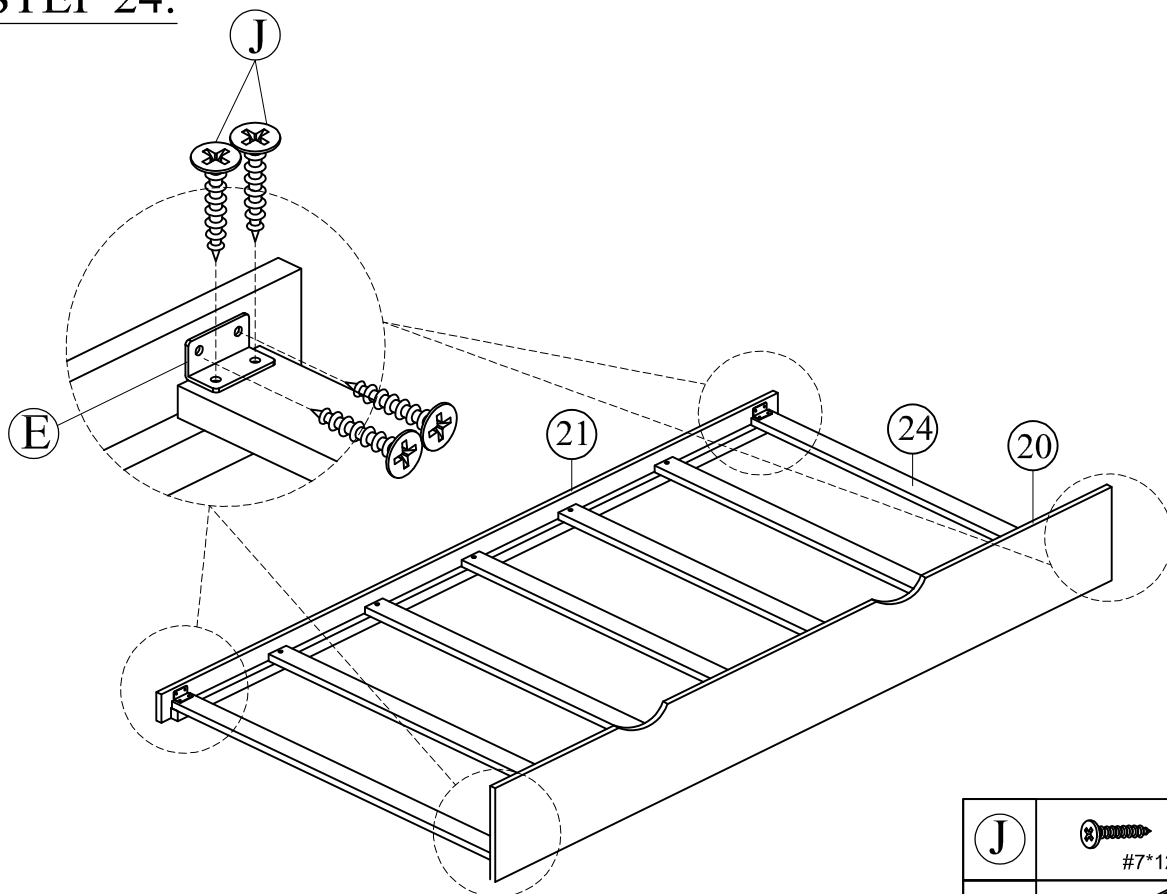

STEP 24:

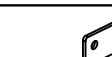

J	 #7*12mm	16pcs 16pièces
L		4pcs 4pièces

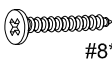
STEP 25:

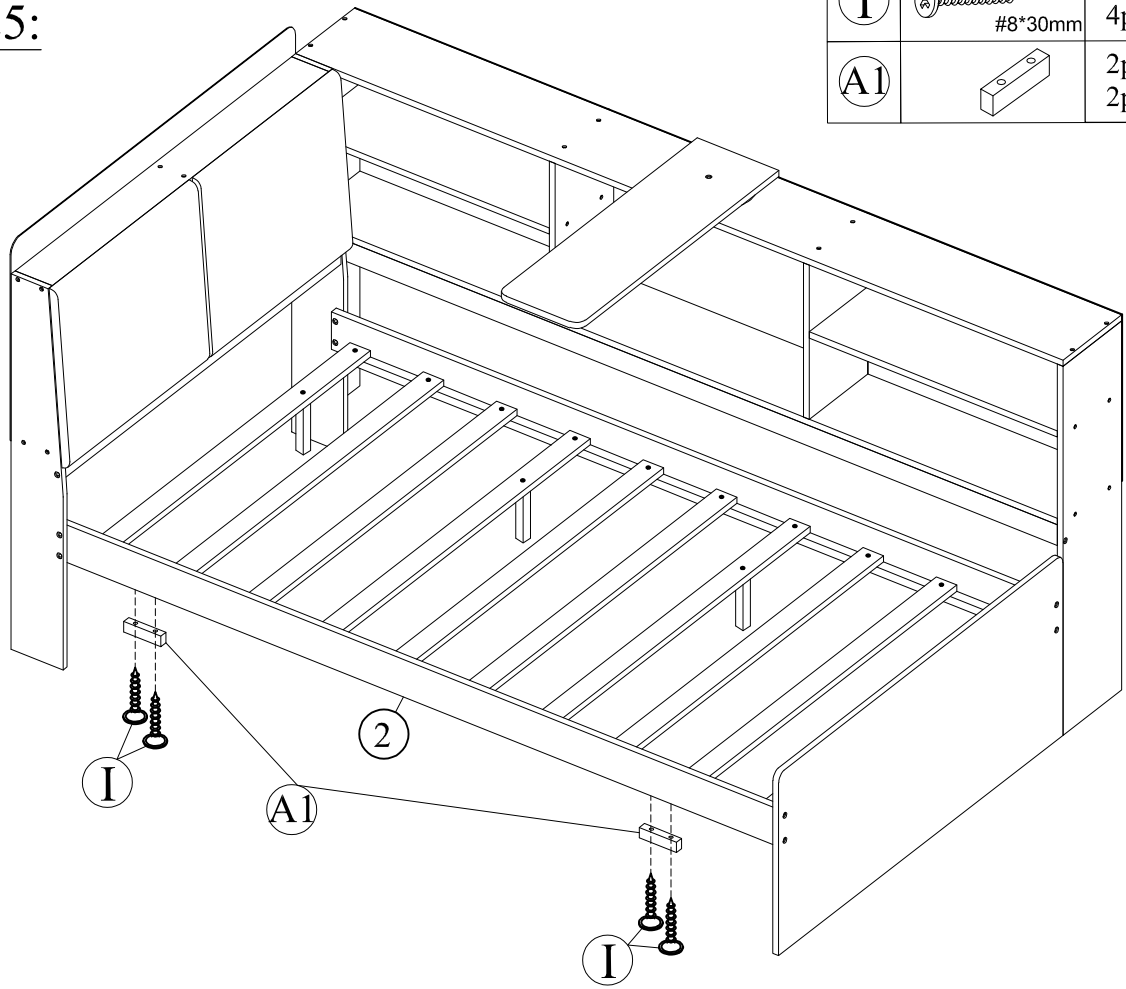

I	 #8*30mm	4pcs 4pièces
A1		2pcs 2pièces

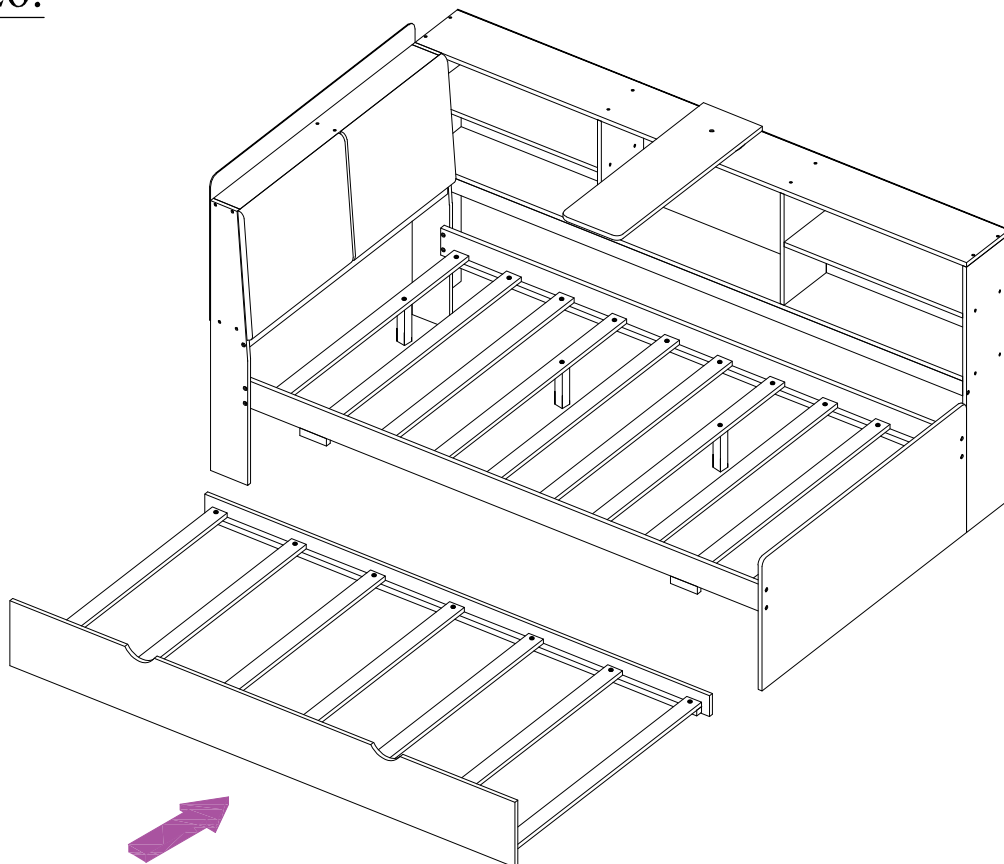

STEP 26:



STEP 27:

Z	 M6*30mm	2pcs 2pièces
I	 #8*30mm	4pcs 4pièces
Q		1pc 1pièce

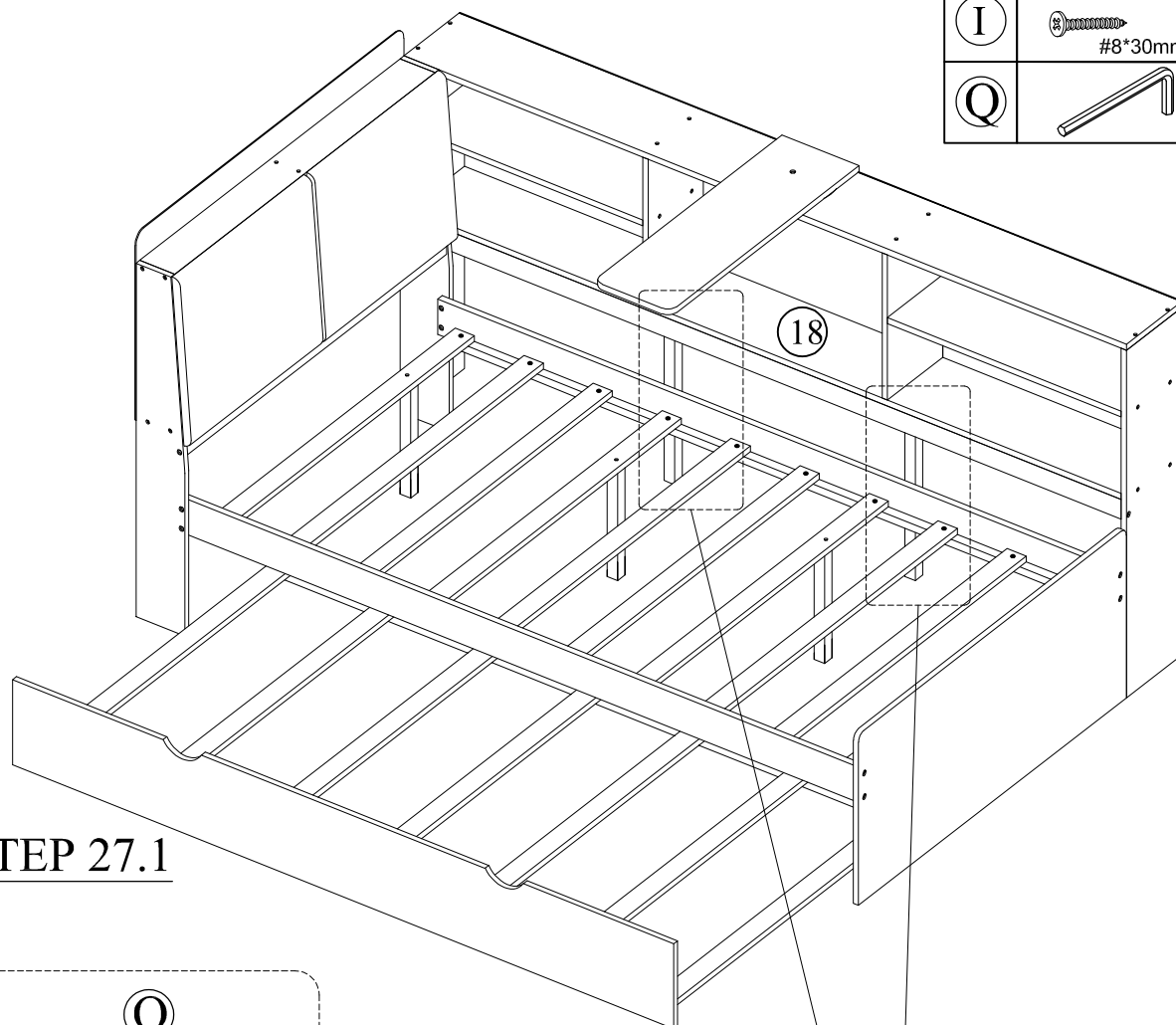

STEP 27.1

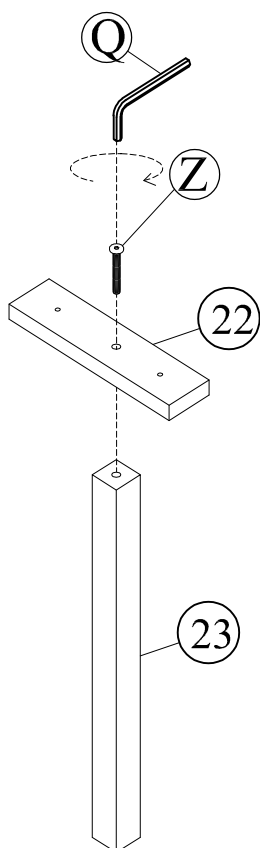

X2

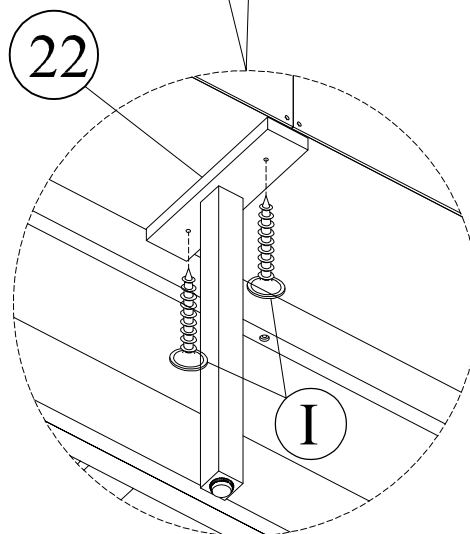
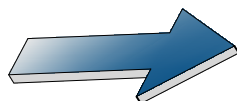

STEP 27.2
ÉTAPE 27.2

FINAL:

