

ASSEMBLY INSTRUCTIONS

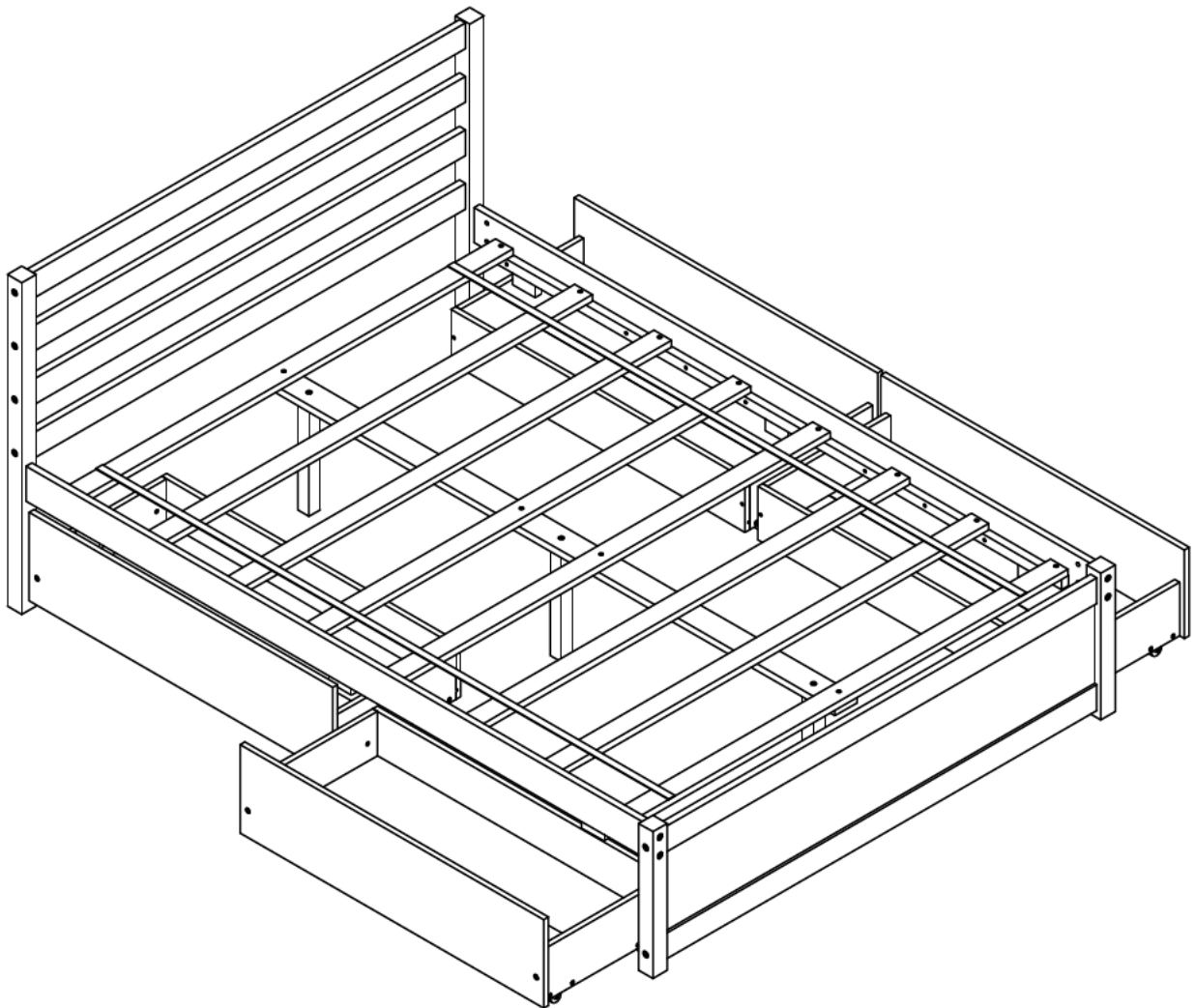

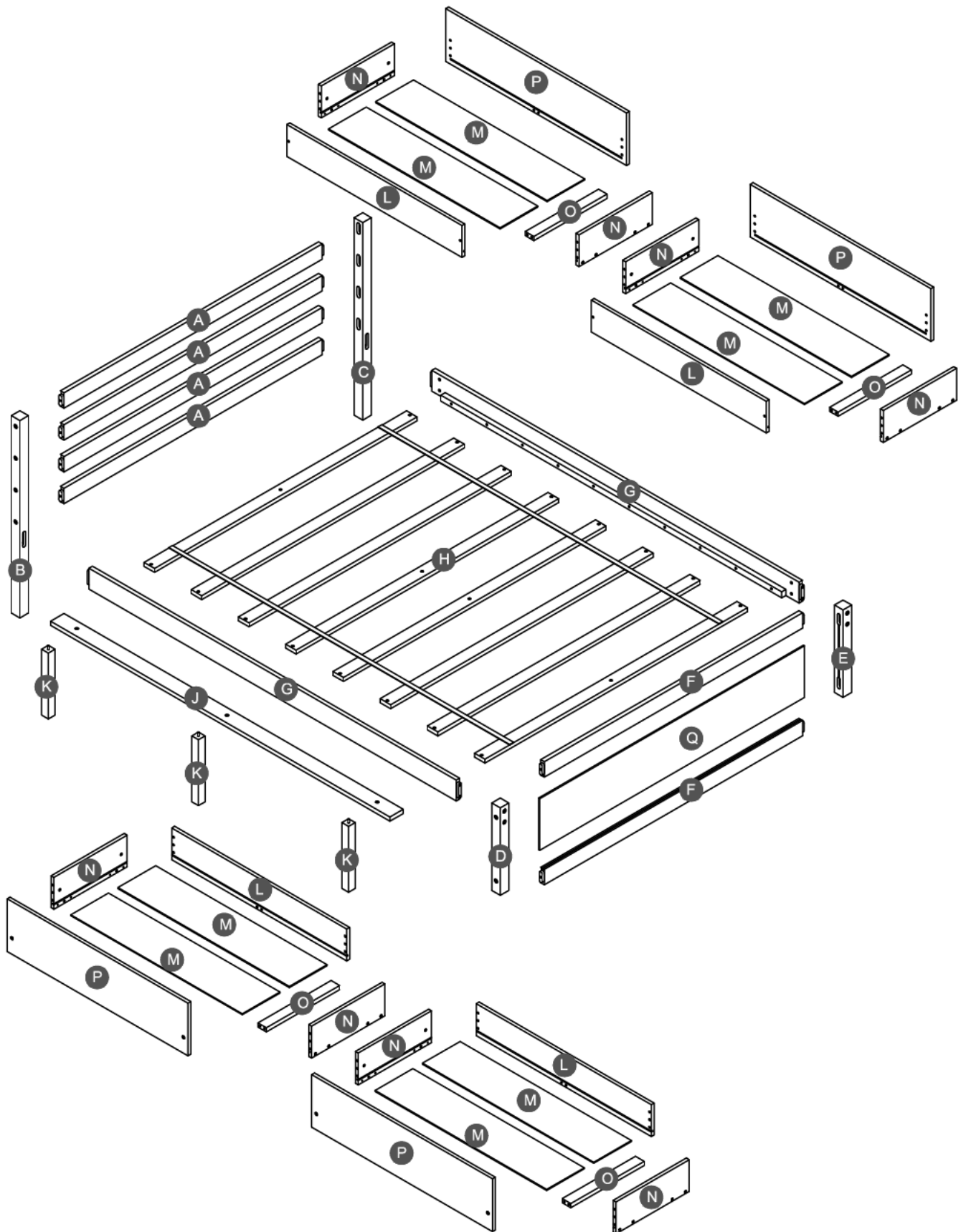







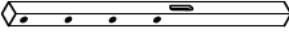

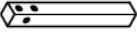
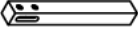
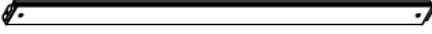
FULL BED WITH 4 DRAWERS

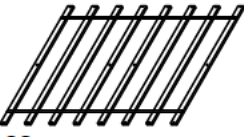

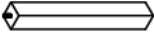

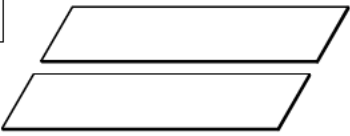
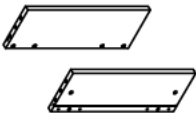



Detail View



Part List

<p>A</p>  <p>Horizontal HB - 4pcs</p>	<p>B</p>  <p>Leg HB (Left) - 1pc</p>	<p>C</p>  <p>Leg HB (Right) - 1pc</p>
<p>D</p>  <p>Leg FB (Left) - 1pc</p>	<p>E</p>  <p>Leg FB (Right) - 1pc</p>	<p>F</p>  <p>FB Horizontal bar - 2pcs</p>
<p>G</p>  <p>Side rail - 2pcs</p>	<p>H</p>  <p>Slat - 8pcs</p>	<p>J</p>  <p>Support slat - 1pc</p>
<p>K</p>  <p>Leg support - 3pcs</p>	<p>L</p>  <p>Drawer back - 4pcs</p>	<p>M</p>  <p>Drawer bottom - 8pcs</p>
<p>N</p>  <p>Drawer (Left / Right)- 8pcs</p>	<p>O</p>  <p>Drawer support - 4pcs</p>	<p>P</p>  <p>Drawer front - 4pcs</p>
<p>Q</p>  <p>FB side panel - 1pc</p>		

Hardware List

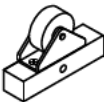
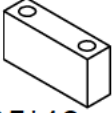
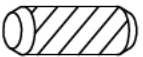
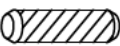
1  (Ø15)1/4"*100mm Hex-Head bolts (8pcs)	2  (Ø15)1/4"*80mm Hex-Head bolts (12pcs)	3  (Ø12)1/4"*60mm Hex-Head bolts (16pcs)
4  1/4"*15 (9.5mm) Horizontal-Hole bolts(36pcs)	5  (1/4")4.5*58mm Allen key (1pc)	6  Ø4*30mm Wood screws (64pcs)
7  100*54*20 mm Wheels (16pcs)	8  70*35*19 mm Drawer stopper (6pcs)	9  Ø10*20mm Wood dowel (16pcs)
10  Ø8*30mm Wood dowel (48pcs)		

ASSEMBLY TOOLS REQUIRED (NOT INCLUDED)

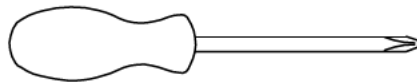

PLEASE BE CAREFUL DO NOT DAMAGE THE HOLE POSITION WHEN YOU USE POWER TOOLS !

STEP 1:

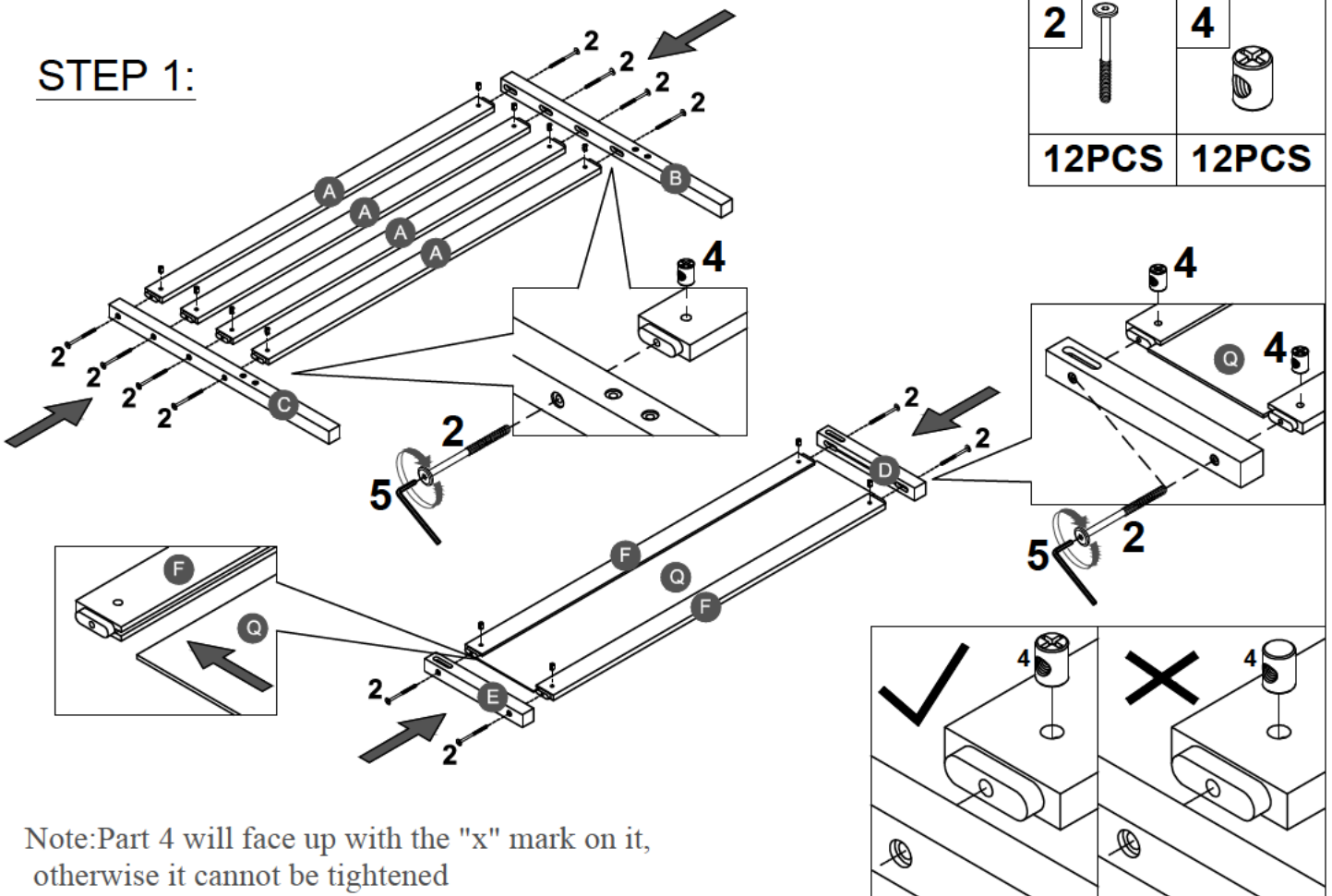

STEP 2:

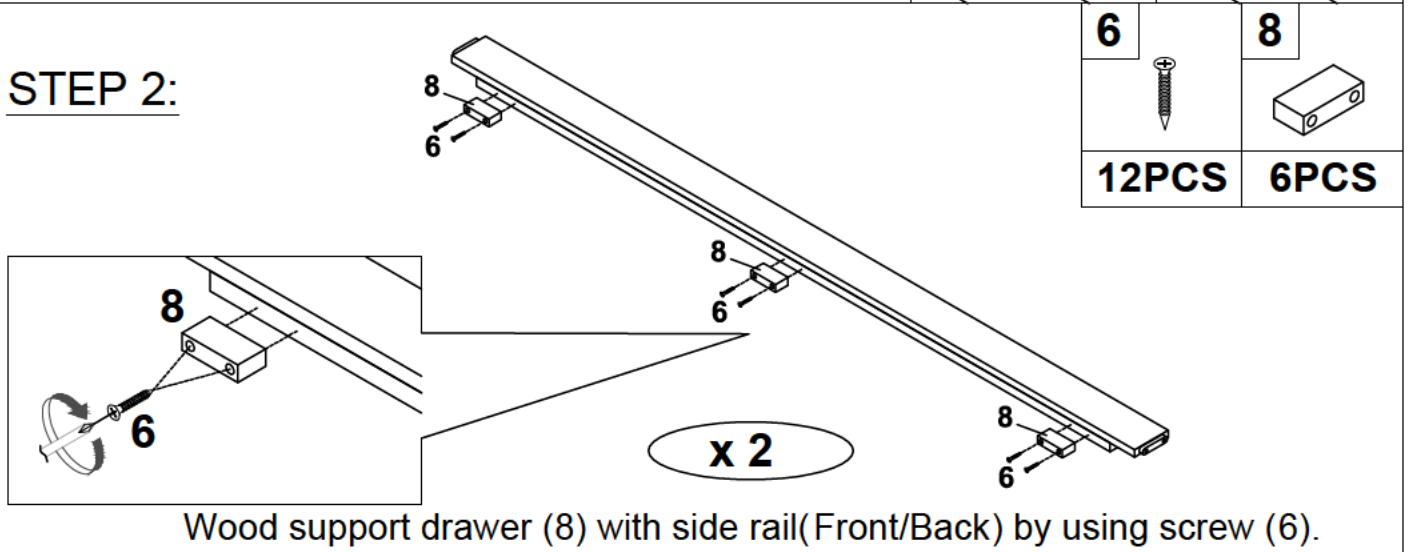

STEP 3:

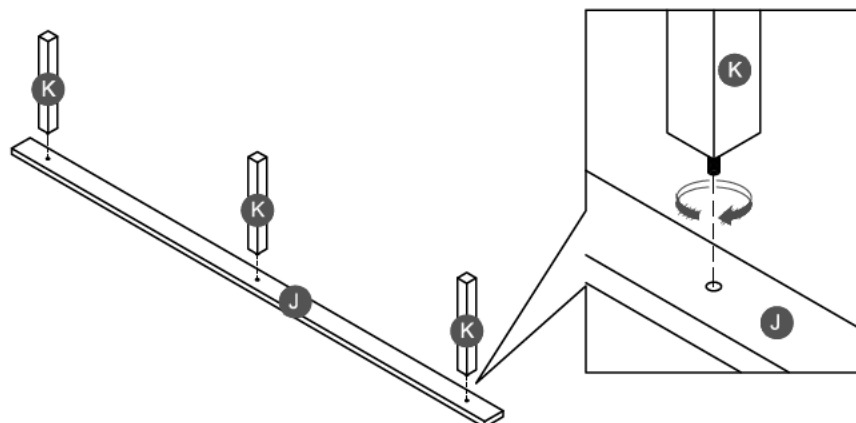

STEP 4:

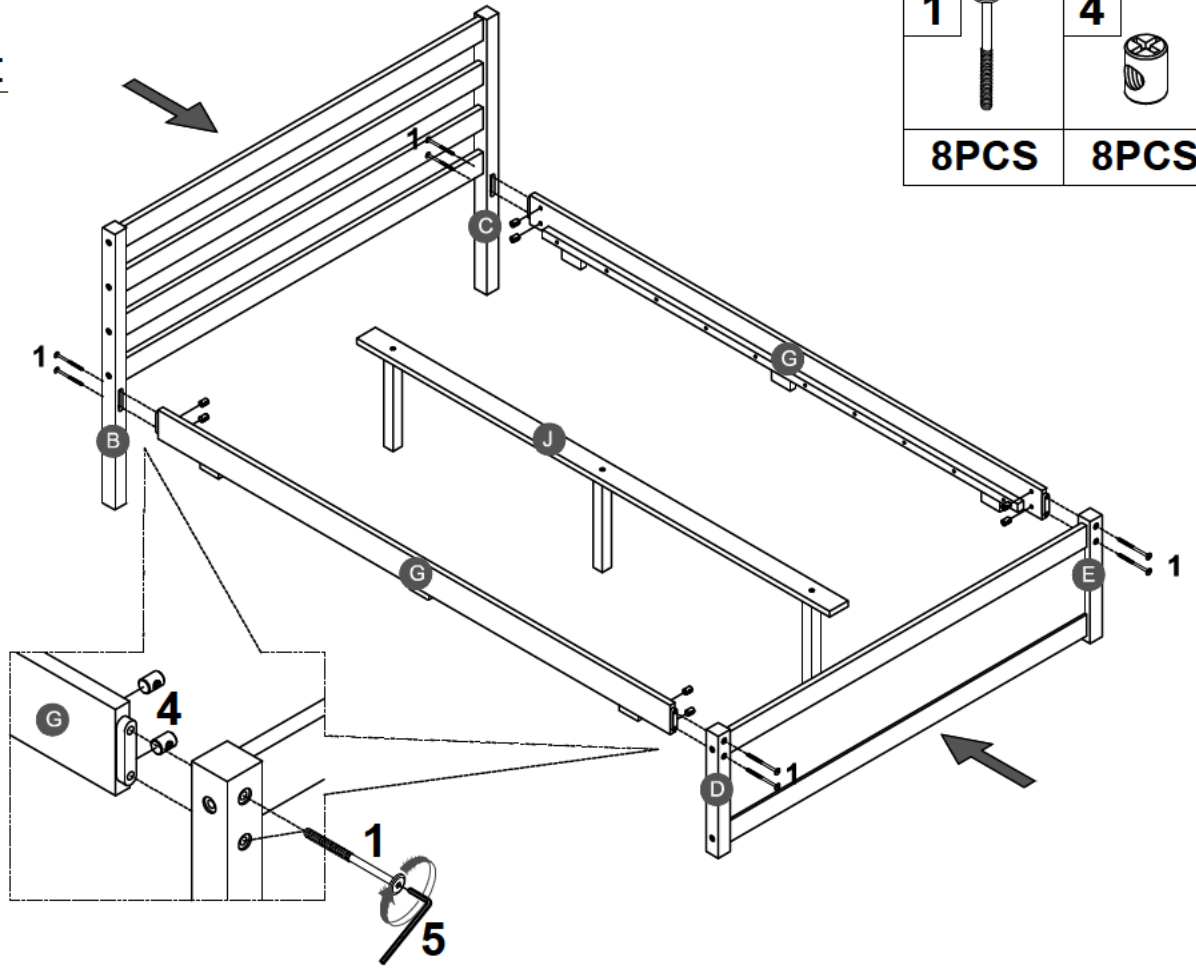

STEP 5:

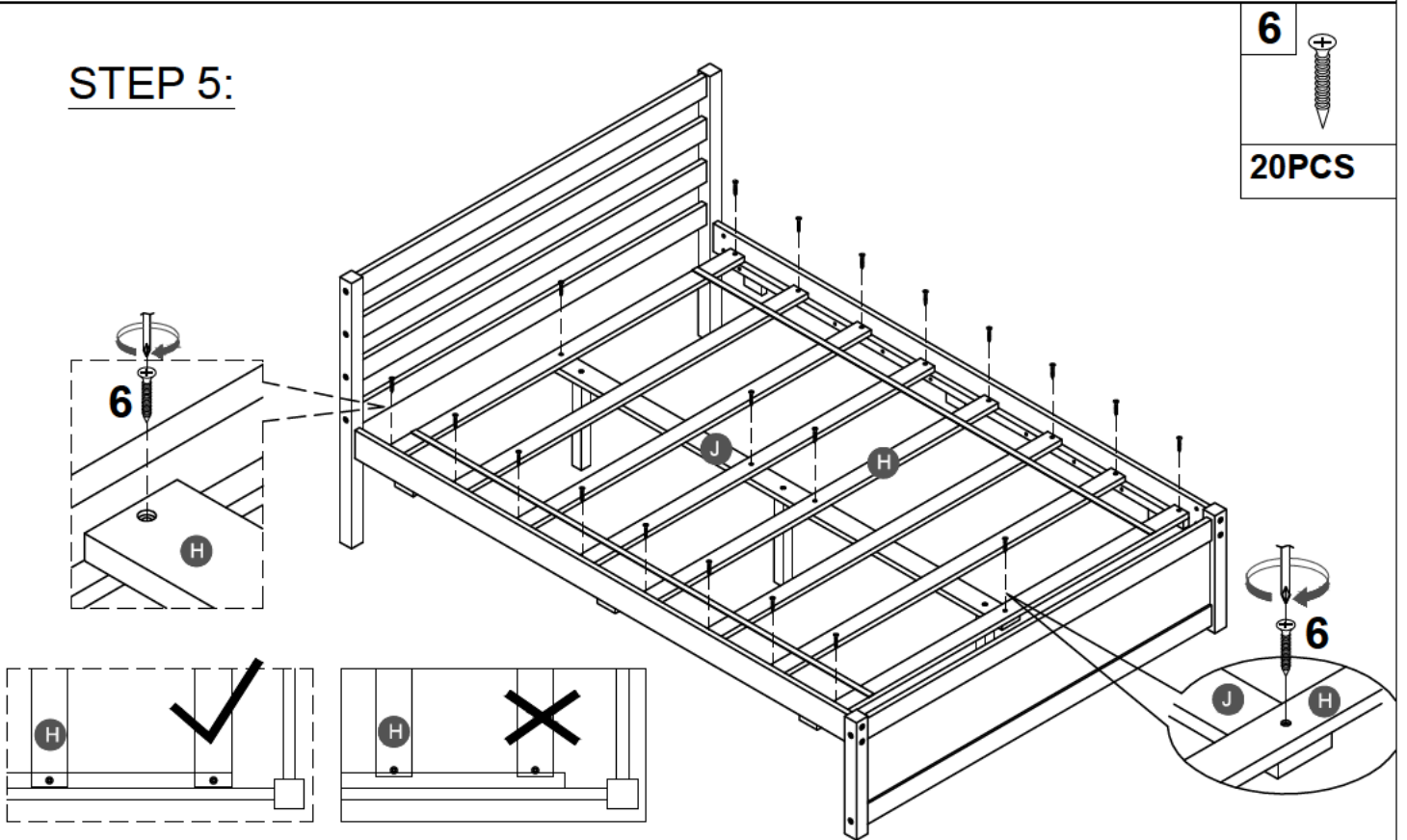

Note: Do not lock the screws of the bed slats to the outermost edge of the bed slats, you need to leave a certain space at the edges, otherwise it will cause the board to break

STEP 6:

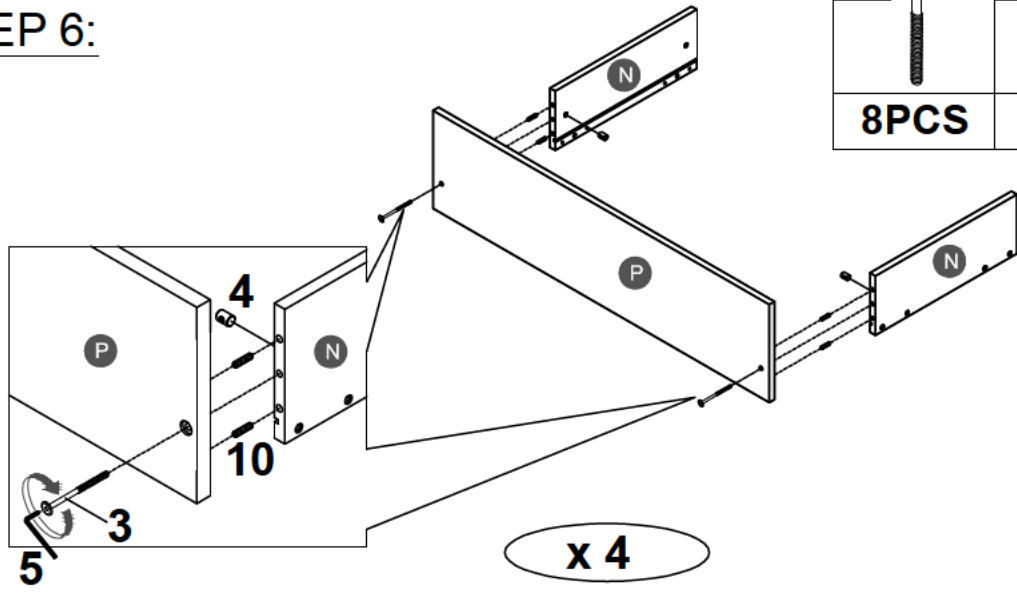

3	4	10
8PCS	8PCS	16PCS

STEP 7:

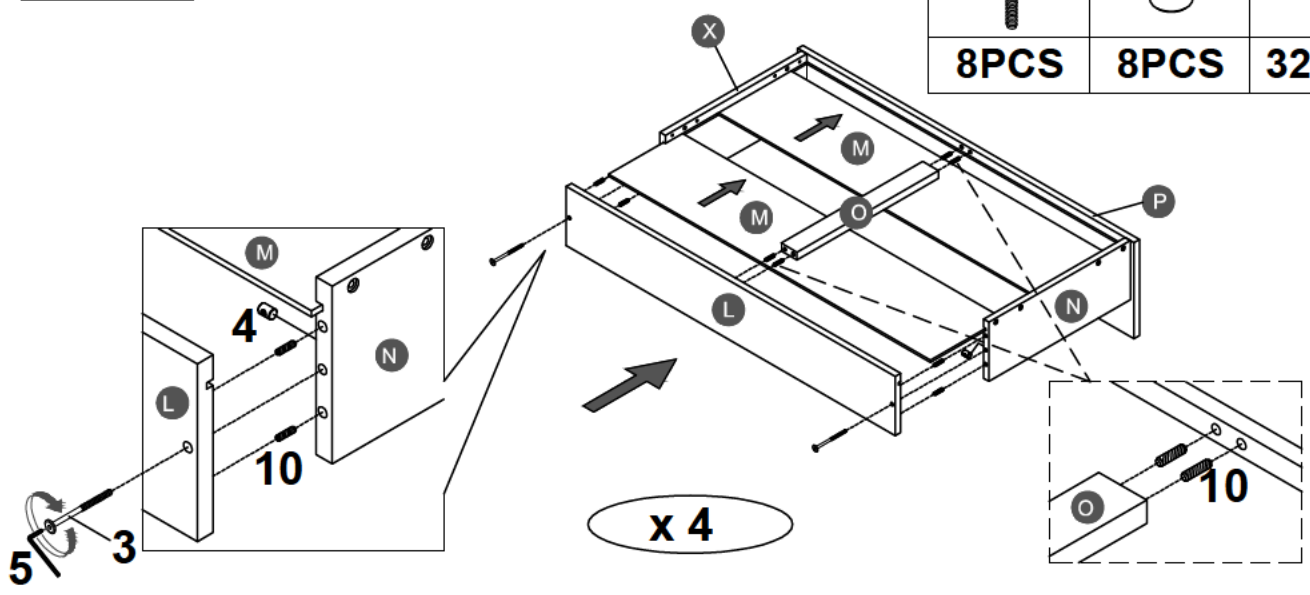

3	4	10
8PCS	8PCS	32PCS

STEP 8:

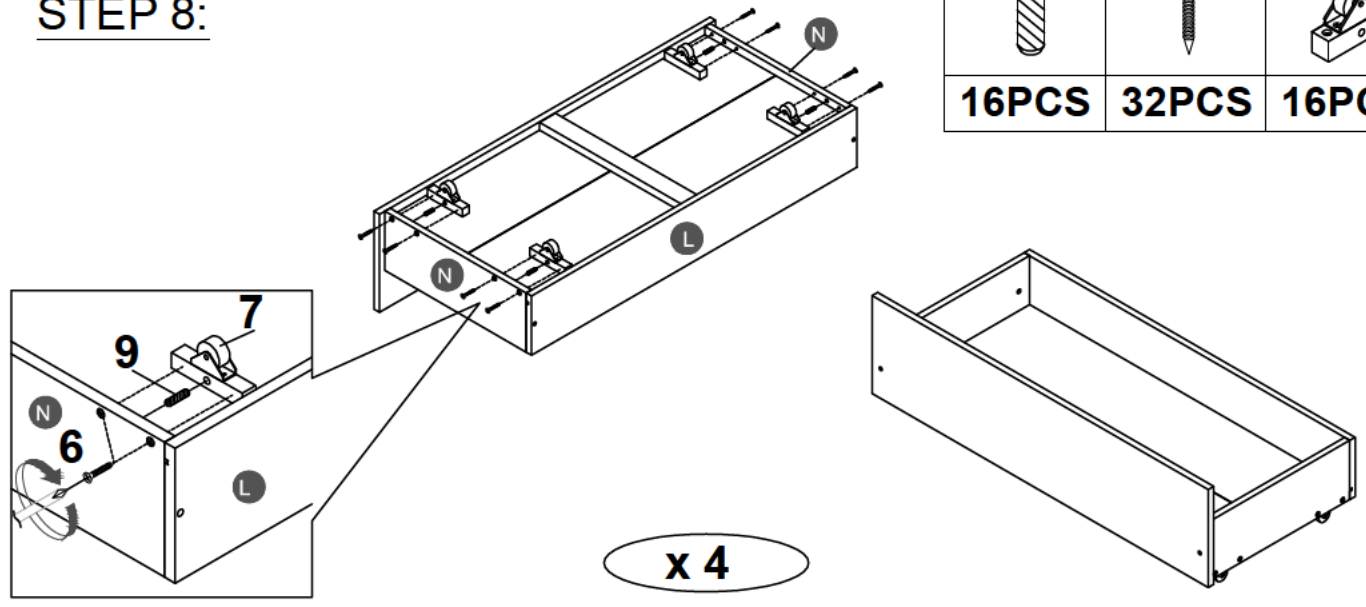

9	6	7
16PCS	32PCS	16PCS

STEP 9:

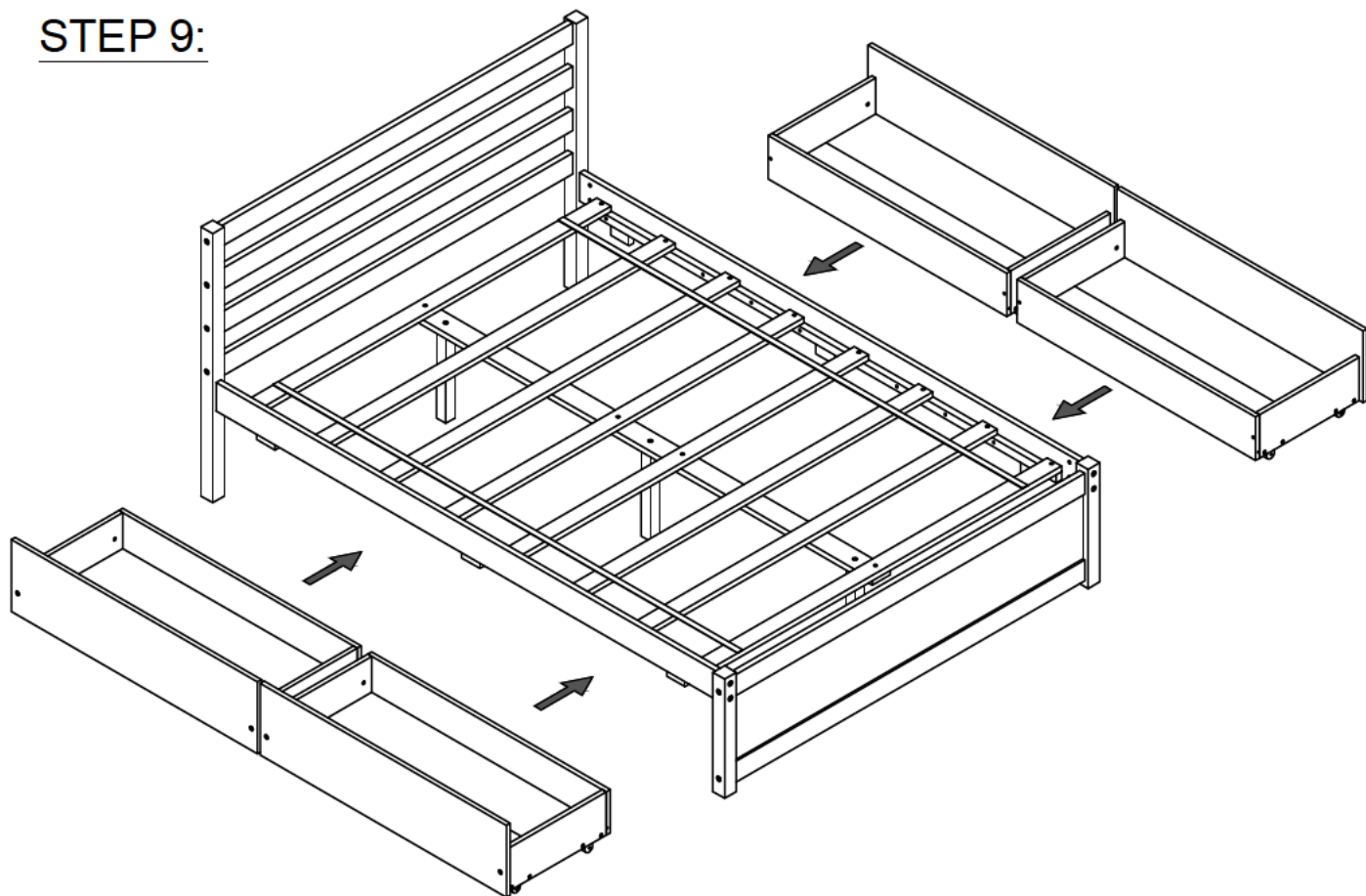

Push Drawer under the bottom of Full Bed.

