

ASSEMBLY INSTRUCTIONS

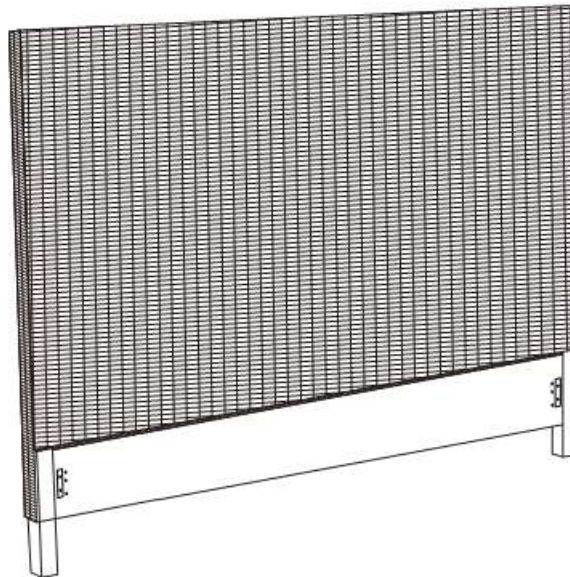

Queen Headboard

ASSEMBLE HEADBOARD TO METAL FRAME

ASSEMBLY TIPS :

1. Remove hardware from box and sort by size.
2. Please check to see that all hardware and parts are present prior to start of assembly.
3. Please follow attached instructions in the same sequence as numbered to assure fast & easy assembly.



WARNING!

1. Don't attempt to repair or modify parts that are broken or defective. Please contact the store immediately.
2. This product is for home use only and not intended for commercial establishments.

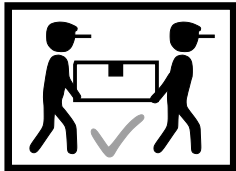

ASSEMBLY TIME

15 MINUTES

PARTS IDENTIFICATION

B1 (BOX 1)

A

HEADBOARD

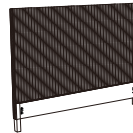

1PC

HARDWARE IDENTIFICATION

Z - B1 (BOX 1) - HARDWARE PACK

| | | | |
|----|---|--|-------|
| 6 | LONG BOLT (Ø7/23" x 2-3/8" - BLK) | | 6PCS |
| 7 | LOCK WASHER (Ø4/16" - RBW) | | 6PCS |
| 8 | FLAT WASHER (Ø4/16" - RBW) | | 12PCS |
| 9 | ALLEN WRENCH (4mm - BLK) | | 1PC |
| 10 | HEX NUT (M 6mm - BLK) | | 6PCS |
| 11 | WRENCH (3-3/8" x 1-1/8" - RBW) | | 1PC |

ASSEMBLE HEADBOARD TO METAL FRAME COMPLETE

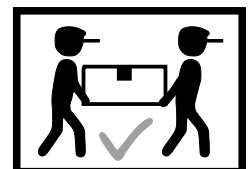
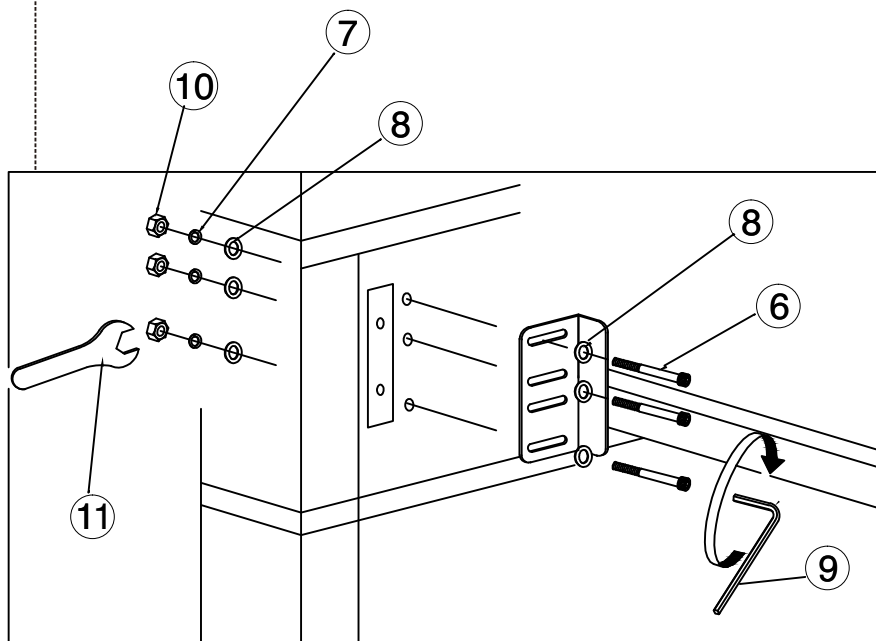
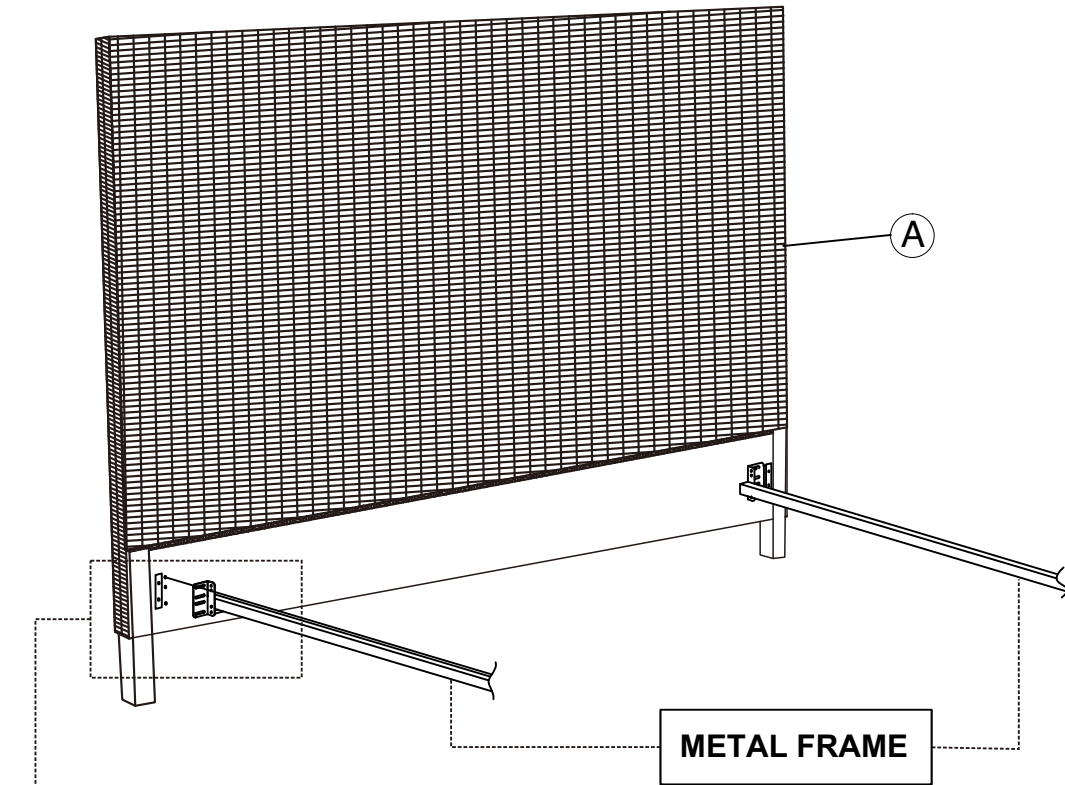

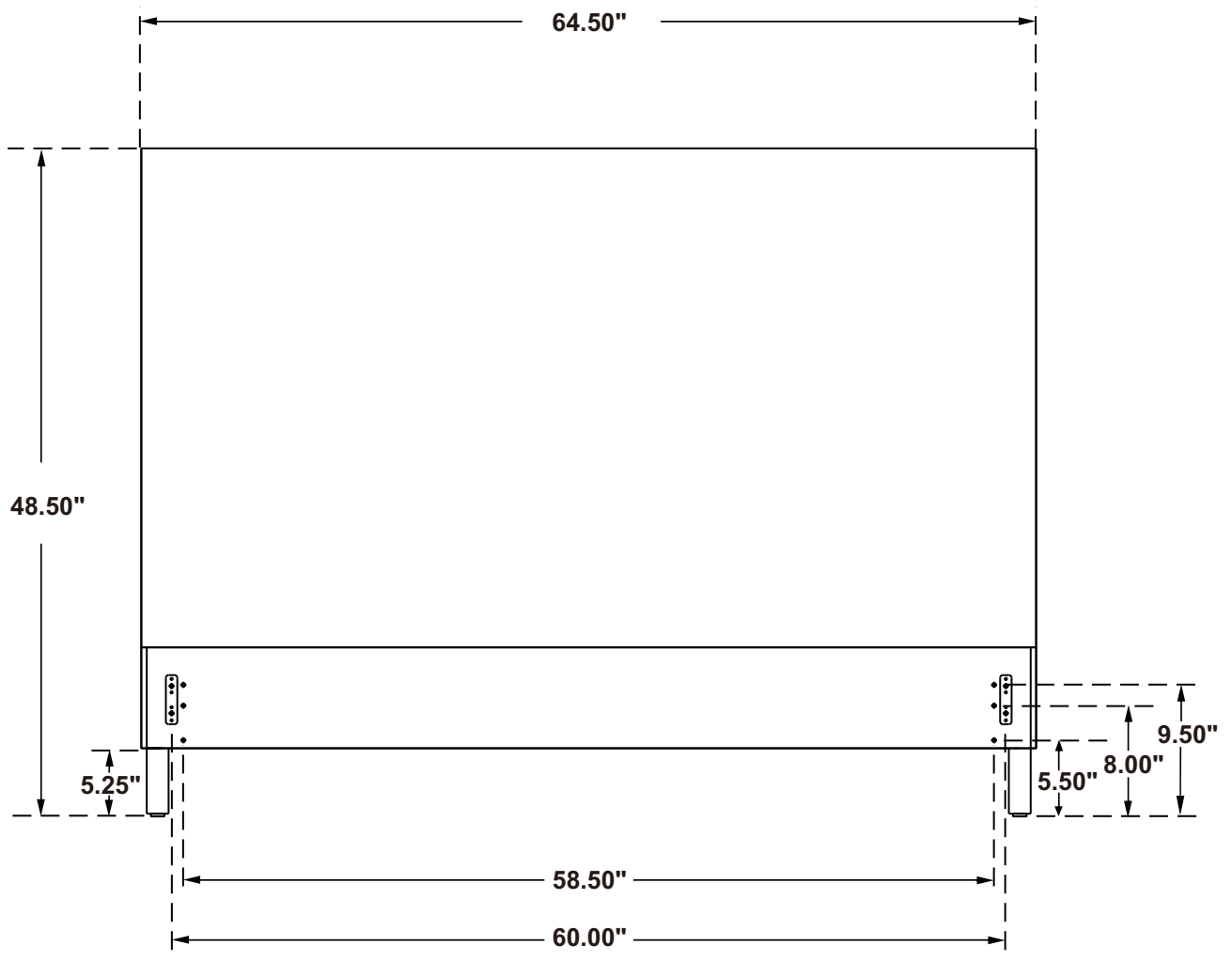

Note: Dimension tolerance $\pm 5\%$