

Outdoor portable Storage Shed Manual

Dear Customer,

Thank you for choosing our product! To ensure your safety and the proper usage of the product, please adhere to the following crucial recommendations during installation and use:

1. Secure the product using sandbags: To enhance the stability and safety of the product, it is imperative to use sandbags during installation. Sandbags effectively prevent unintended movement or tilting of the product, providing additional support and stability.
2. Avoid installing near or directly on air vents: Air vents can cause airflow variations that may adversely affect the normal operation of the product. Choose a location away from air vents to ensure the product's stability under various environmental conditions.

Our objective is to provide you with the highest quality and safest product experience. If you have any questions regarding installation or usage, please feel free to contact our customer service team. Once again, thank you for choosing our product, and we wish you a delightful user experience!

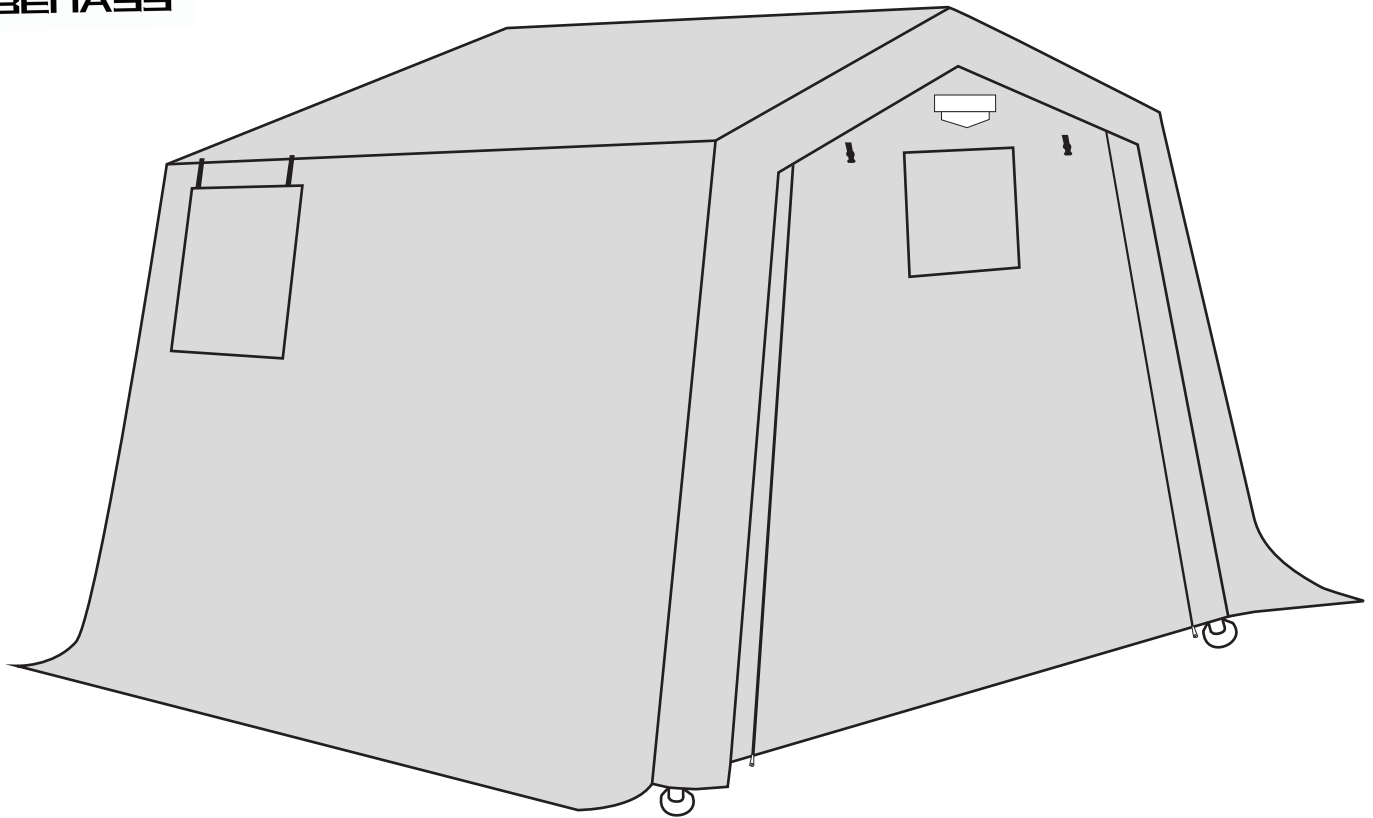







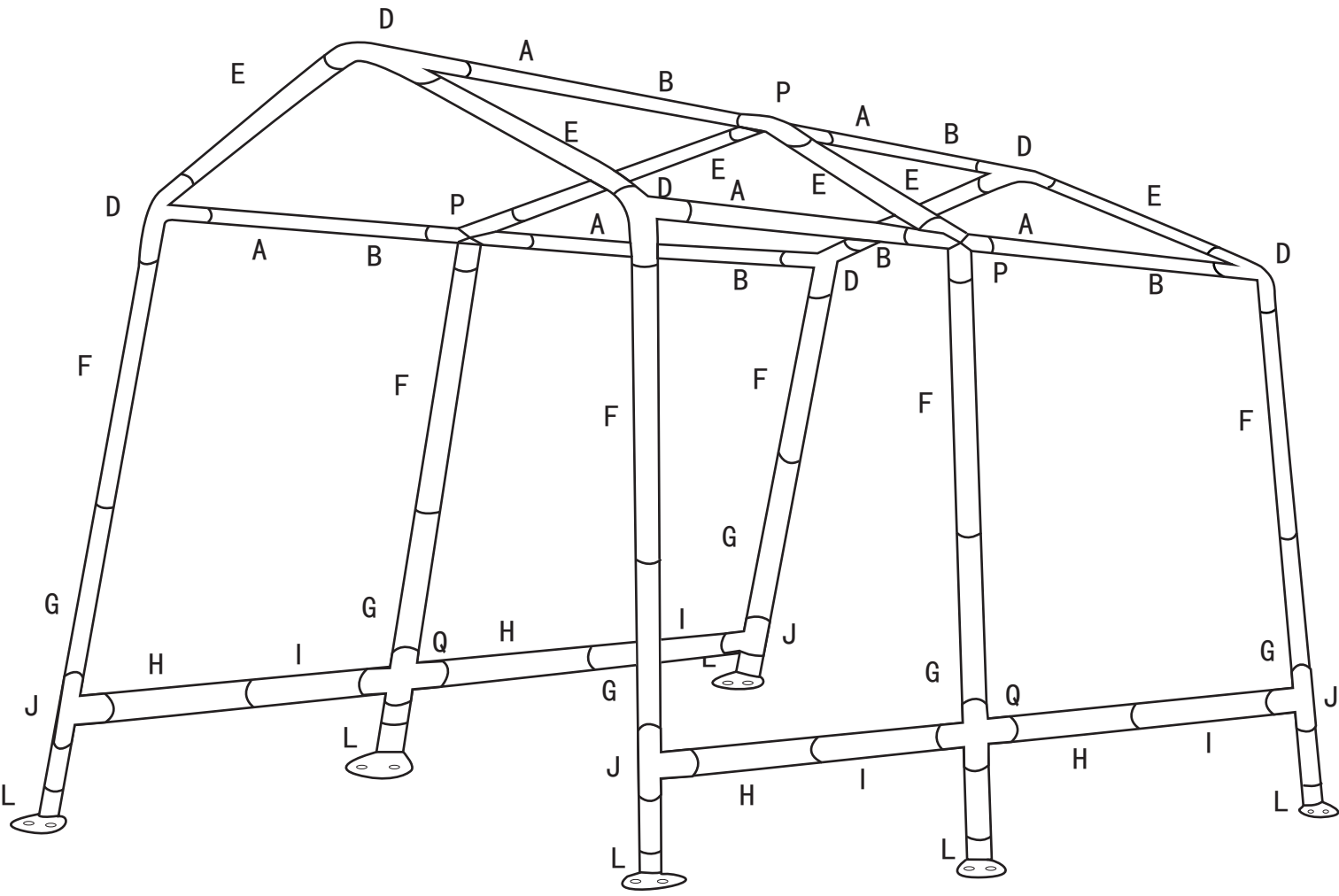

7x12FT Outdoor portable Storage Shed



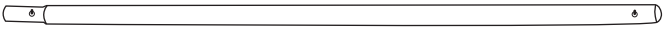

Phone: 3022415039/6605538327
Email: easyhelpservice@yahoo.com
Please contact us by phone or email.

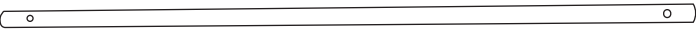
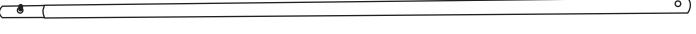
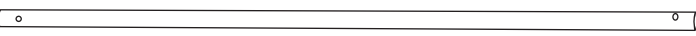
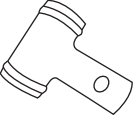
After-sales phone service hours:
US Central Time: 19:00-23:00
Seattle time: 17:00-21:00
US Eastern Time: 20:00-00:00
Toronto time: 20:00-00:00
Germany time: 8:00-11:00
After-sales mailbox service time: 7*24 hours

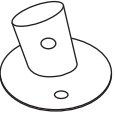
Assembly Diagram

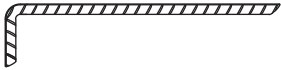
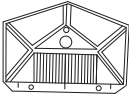
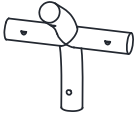
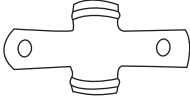

Letter	Illustration	Description	Q'ty
A		Crossbeam	6
B		Crossbeam	6
C		horizontal sleeve	6
D		Tee-junction	6
E		Slant beam	6
F		Post	6
G		Post	6
H		Fabric tube	4
I		Fabric tube	4
J		T-joint	8
K		Elastic cord	28
L		Base	6

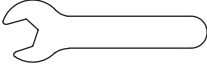
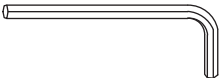
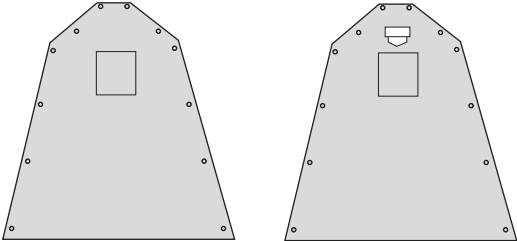
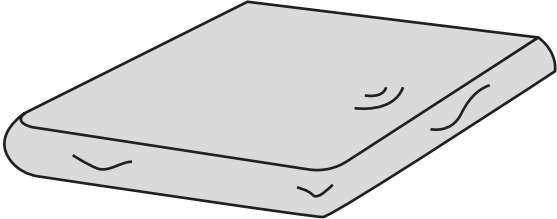
Letter	Illustration	Description	Q'ty
M1		M6*40	8
M2		M6*50	6
N		Stake	12
O		Solar Lamp	1
P		Cross fitting	3
Q		four-way joint	4
R		Sand bags	2
V		Hook	4
W		Wrench	1
Z		Wrench	1
S		Door	2
U		Canopy&Wall	1

Step 1

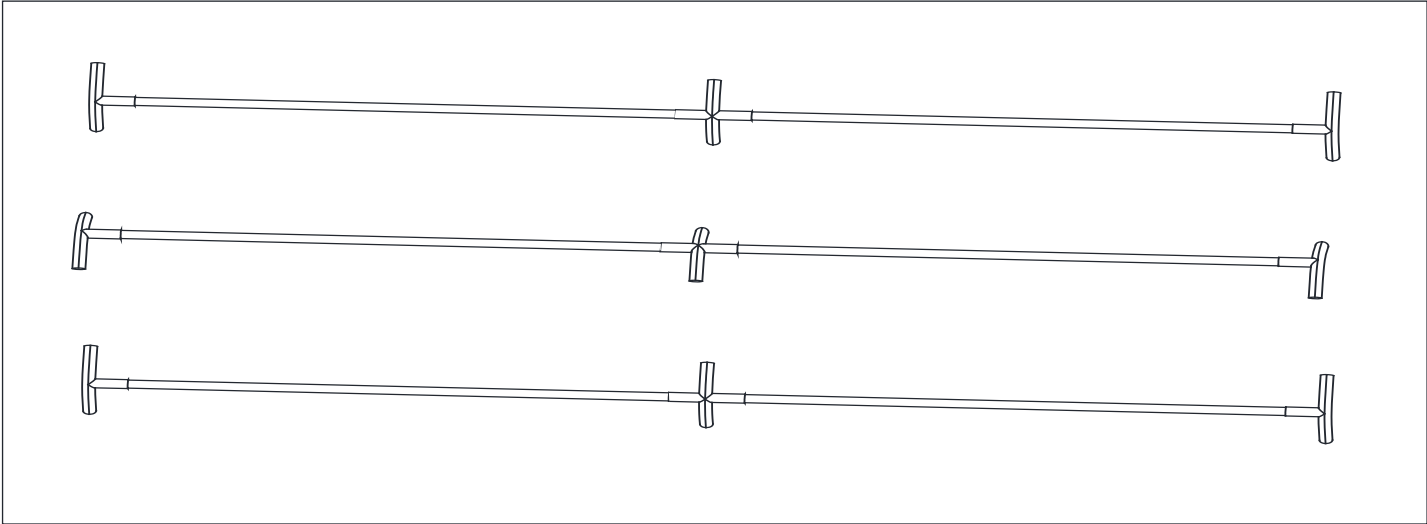
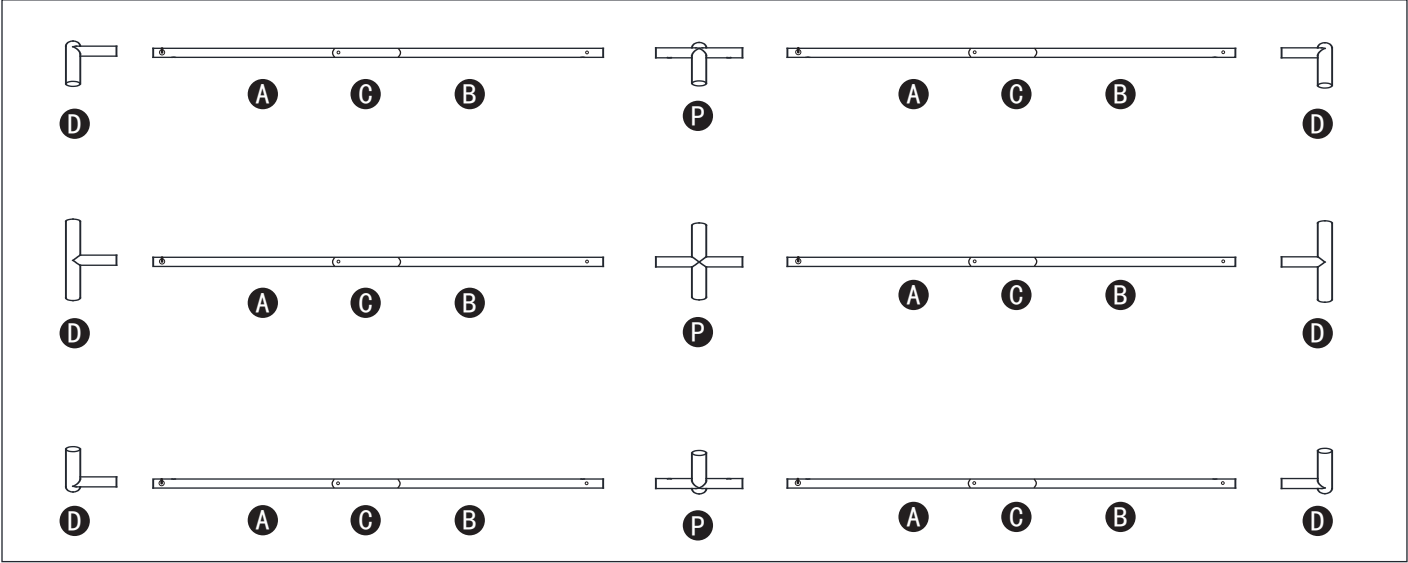
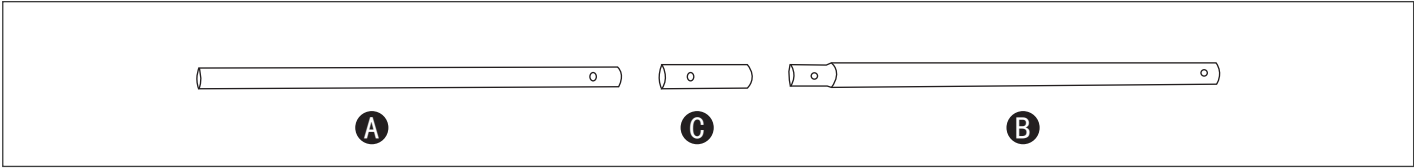

1. Connect D to A. Insert A into tube C, then connect B to C, ensuring that the hole on C aligns with the joint between A and B. Finally, connect B to D.

Step 2

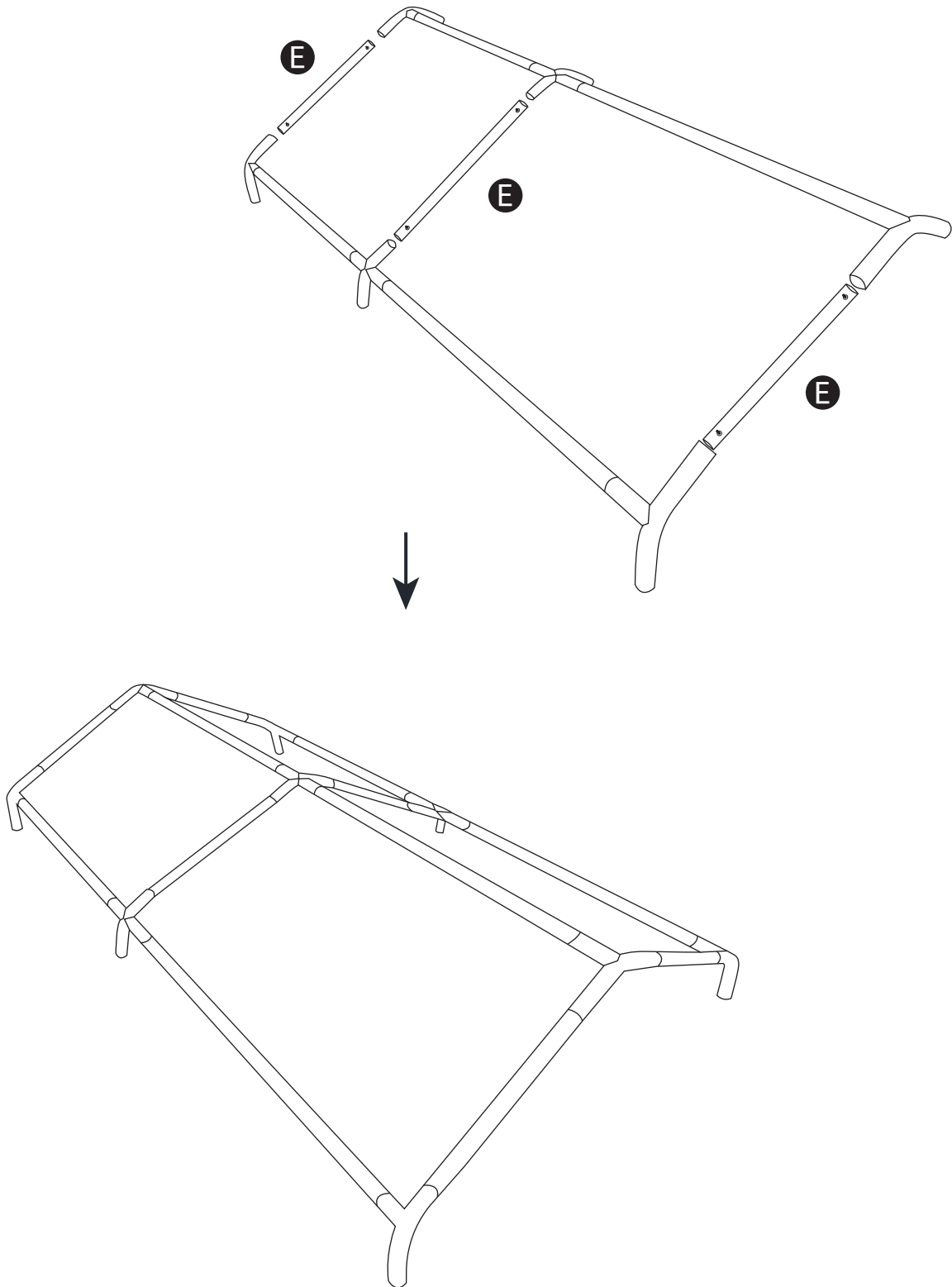

2. After assembling $D \rightarrow A \rightarrow C \rightarrow B \rightarrow D$ in order, connect both ends of E to the two D components on either side.

Step 3

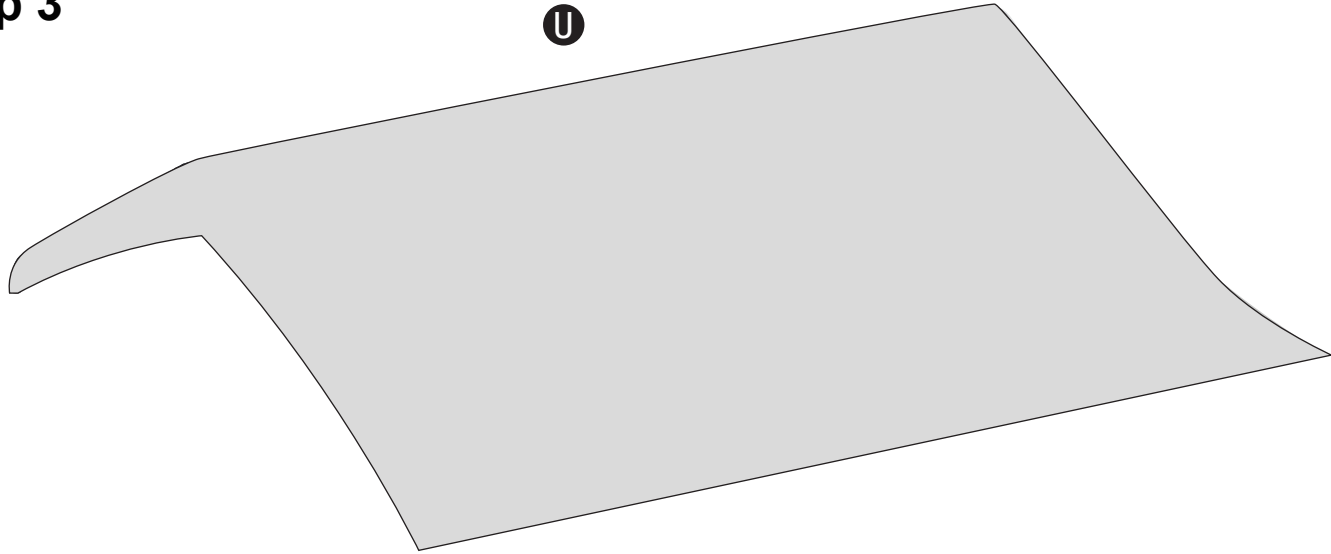

3. Once the roof structure is assembled, place the canopy fabric U over the top structure.

Step 4

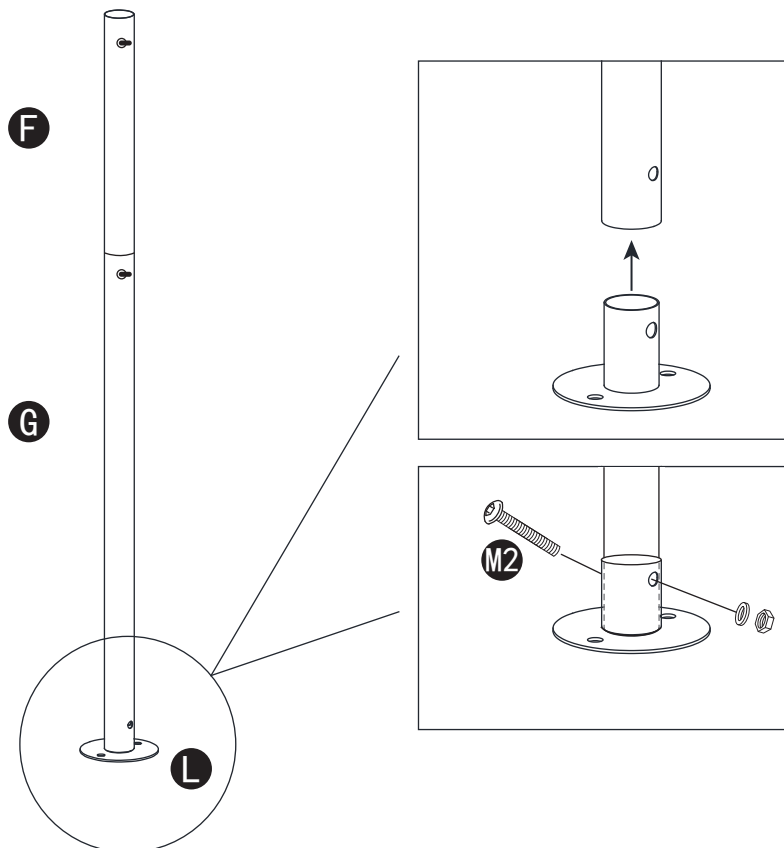

4. Assemble the leg tube structure: Connect the blind hole of F to G. Attach the other end of G to L, aligning the through-hole of G with the base L, and secure it using part M2.

Step 5

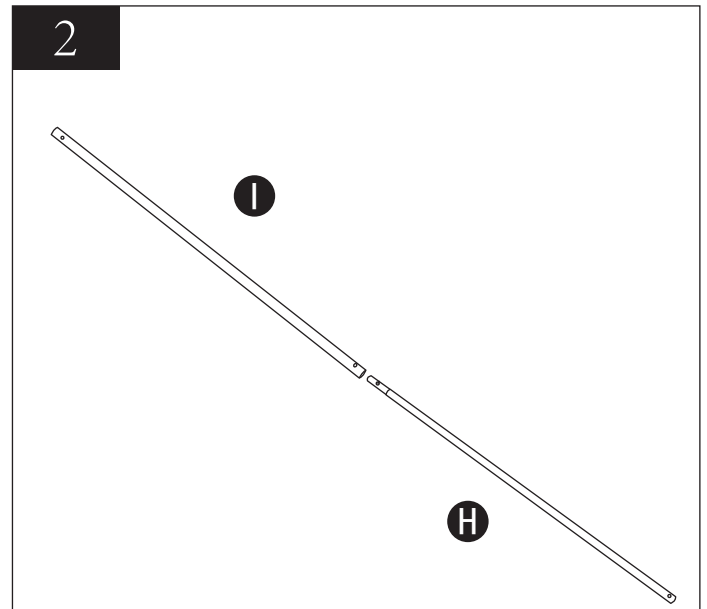
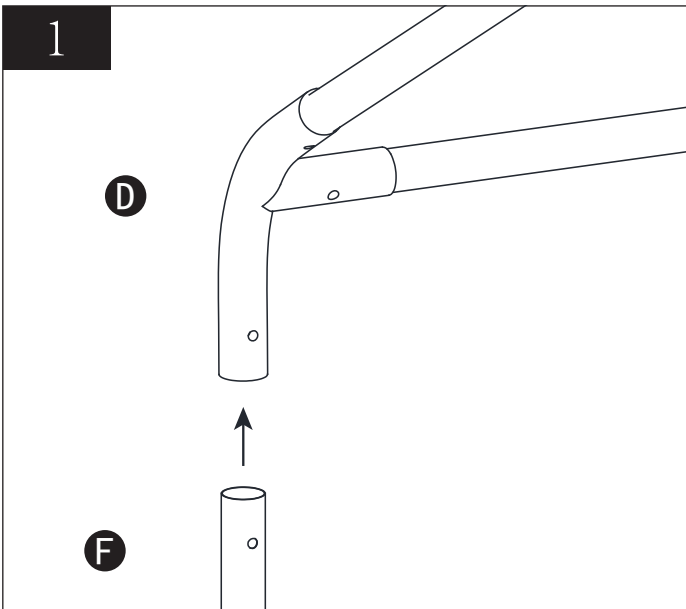
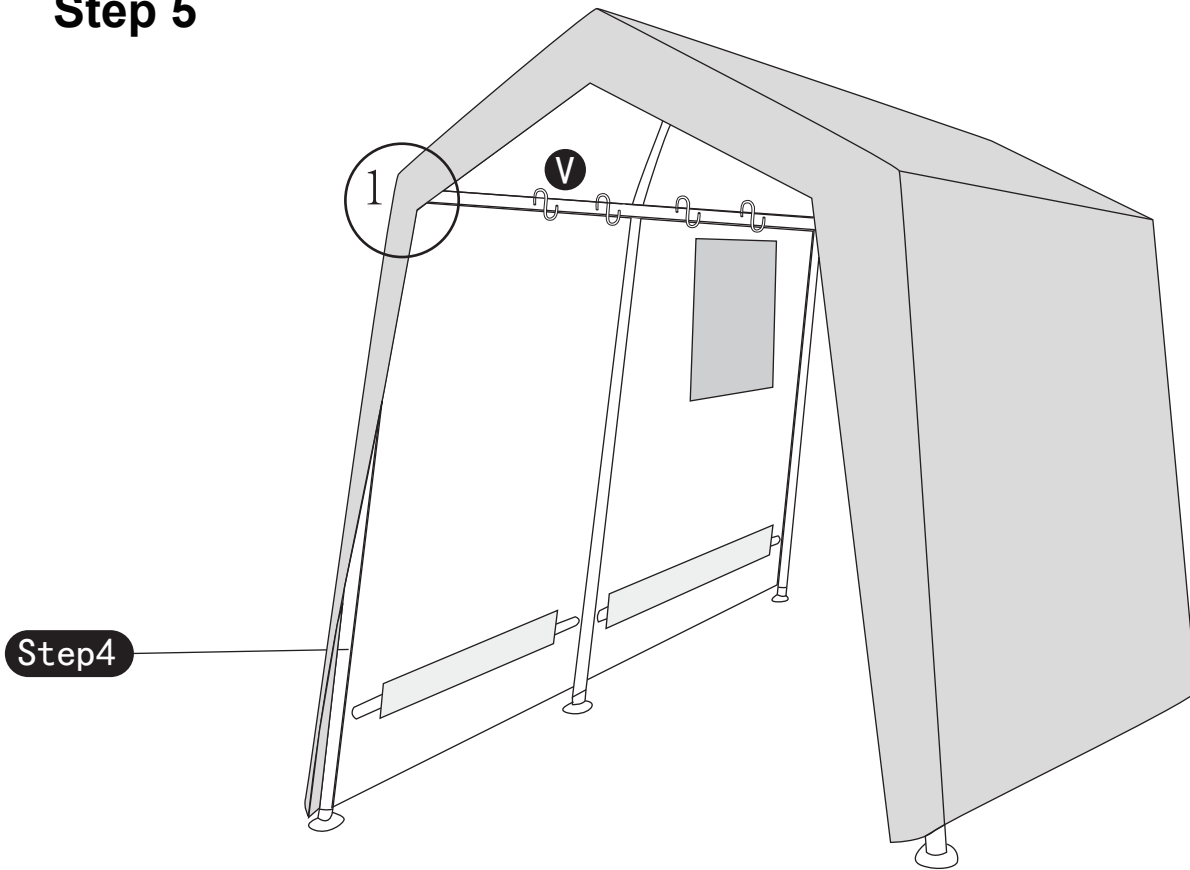

Slide the Post into the Tee-junction (E) and Cross fittings (F).

Insert the connected (I) and (H) into the fabric conduit below the surrounding fabric.

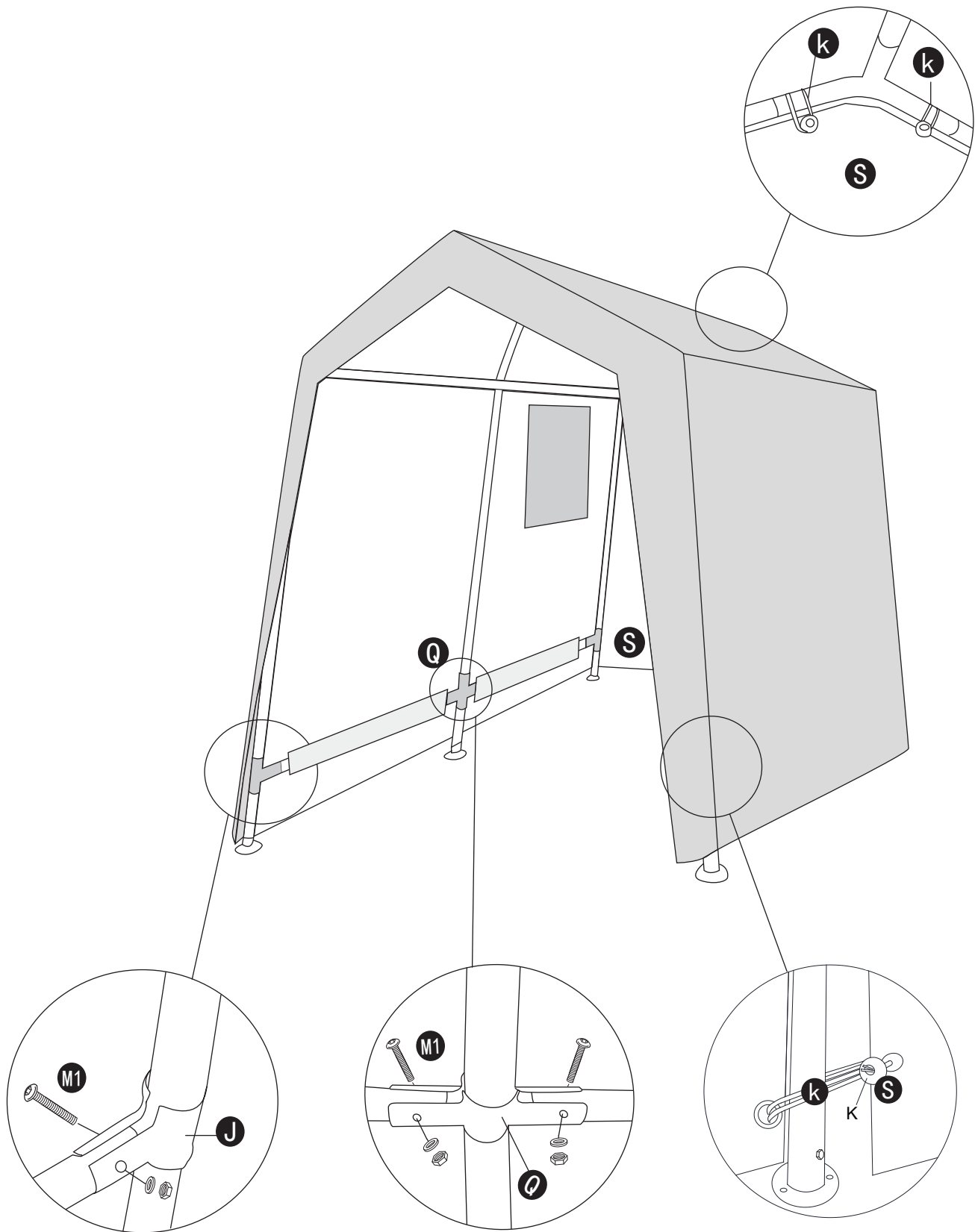

6. Use two T-connector pieces J to secure the junction between the leg pipes and the fabric pipe. Then, use part M1 to fix the T-connector pieces J in place. Finally, thread the elastic cord K through the corresponding holes in the canopy fabric S.

Step 7

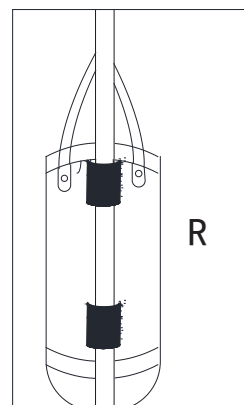
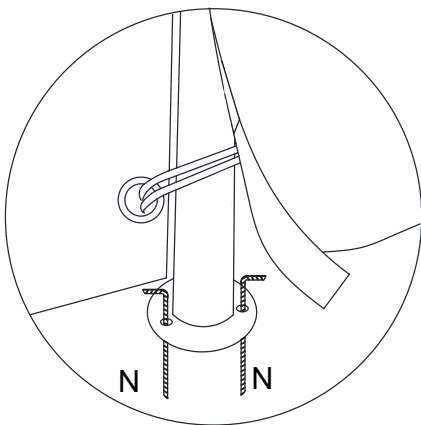
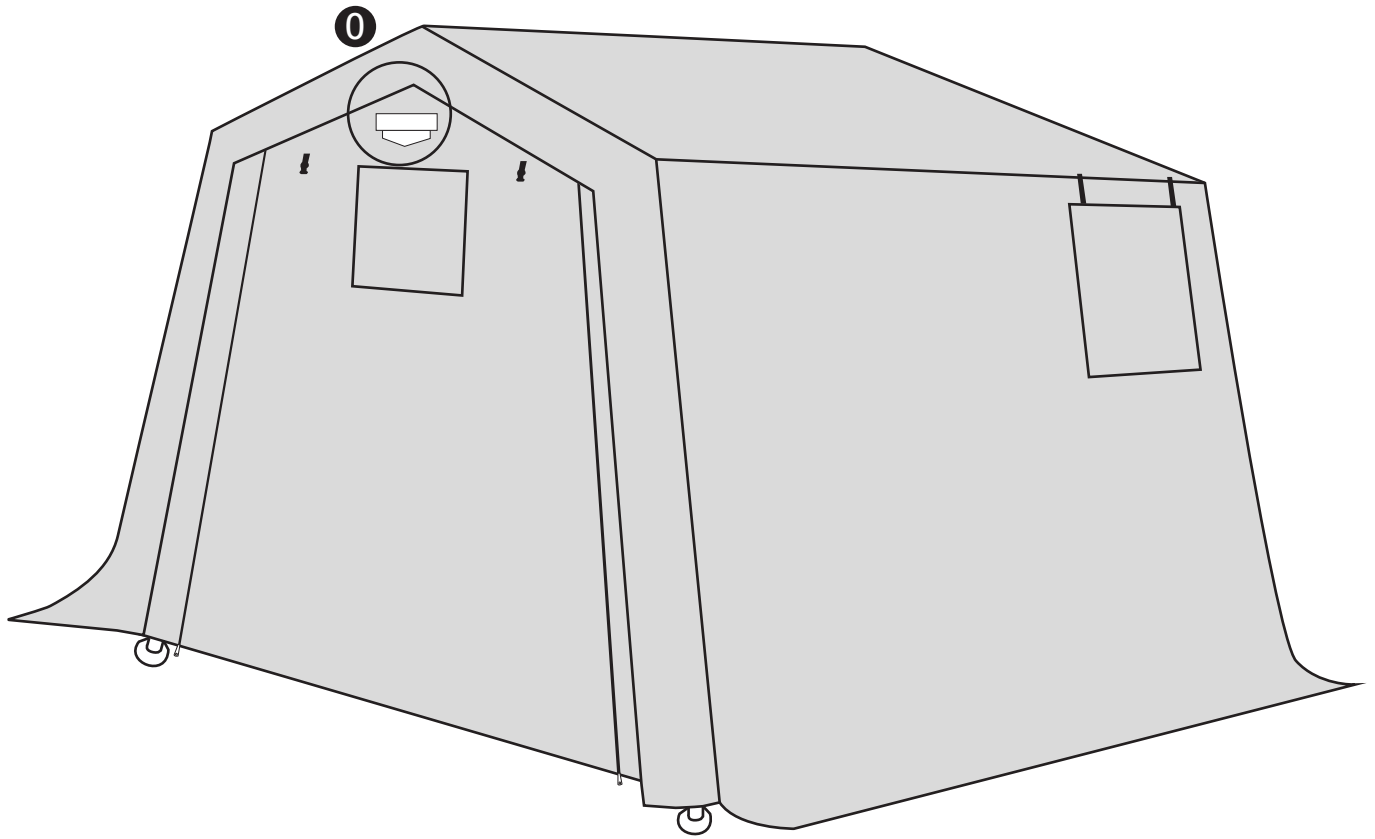

7. Insert ground stake N into the hole on base L and hammer it into the ground. Then, secure sandbag R around the tube.