









Assembly Instructions

CAUTION: You must read these Assembly Instructions before you proceed.

Care & Maintenance

- ⊘  • Not for commercial use. For residential use only.
- ⊘  • Do not put hot items directly on furniture surface.
- ⊘  • Do not clean furniture with harsh cleansers or polish.
- ✓  • To obtain the longest lifespan of your outdoor products, minimizing exposure to direct sunlight is recommended.
- ⊘  • Children should not climb or jump on the furniture.
- ⊘  • Do not write on furniture without a padded barrier to protect the surface.
- ⊘  • To obtain the longest lifespan of your outdoor products, avoid extended and lengthy exposure to rain, snow, and direct sunshine. Whenever possible cover the product and /or place under patio or awnings.
- ⊘  • Stains may be removed with mild soap solution and damp cloth.
- ✓  • Dust and pick-up spills using a clean, non-colored, lint-free cloth.

Please look underneath the Seat Panel for hardware packs.

Sofa

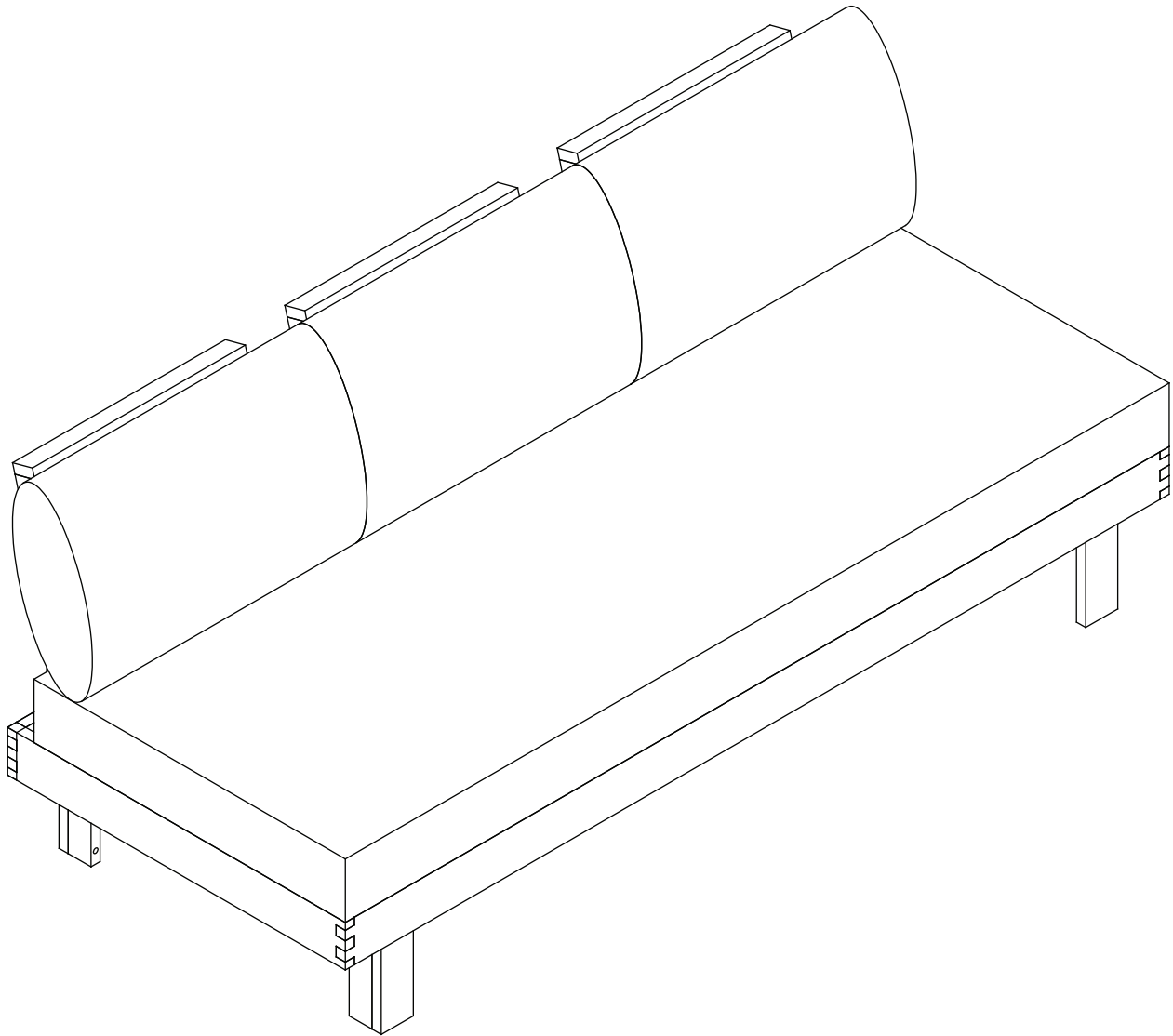



CAUTION: This Sofa is NOT a TOY



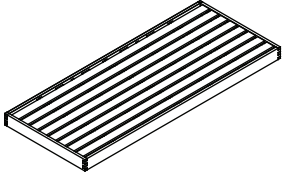

Keep your child/children at bay during the assembly process.

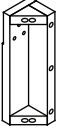
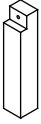
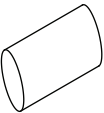
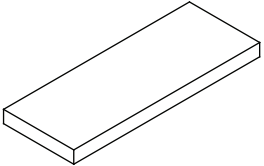
Whenever moving/lifting the Sofa and to prevent damage to the Sofa, two adults are needed to execute these actions.

Parts List

Label	Picture	Description	QTY
A		Backrest Panel	3
B		Seat Panel	1
C		First Leg	2
D		Second Leg	2
E		Mid Leg	1
F		Back Cushion	3
G		Seat Cushion	1

Hardware

Label	Picture	Description	QTY
①		Bolt (M6x25mm)	13
②		Bolt (M6x50mm)	13
③		Bolt (M8x45mm)	2
④		Allen Wrench	2

Assembly Preparation

Before Beginning Assembly:

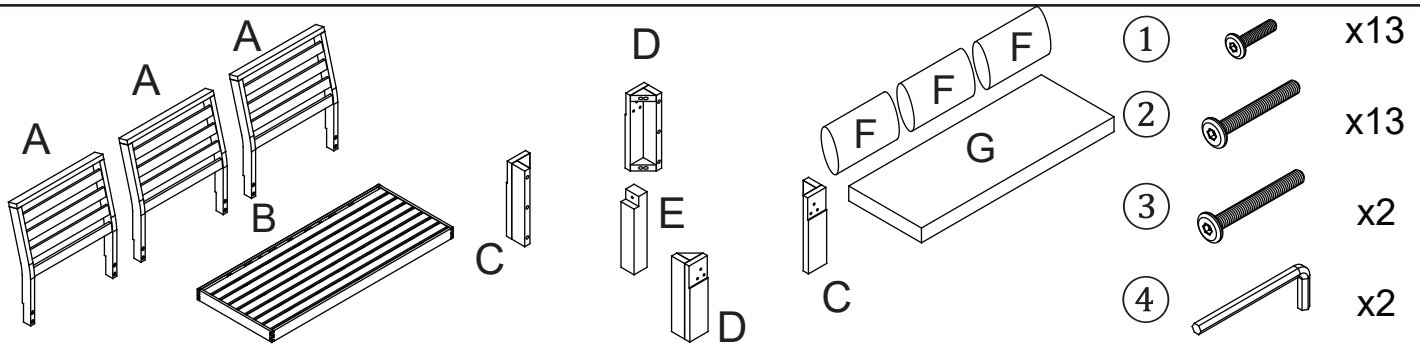

● Read instructions, cover to cover.



● Have 2 adults on hand for assembly.



● Do not assemble on flooring or carpet.



● Assemble on a clean non-marring surface (packing foam).



● Save all packaging until finished.

Assembly Steps

Overview

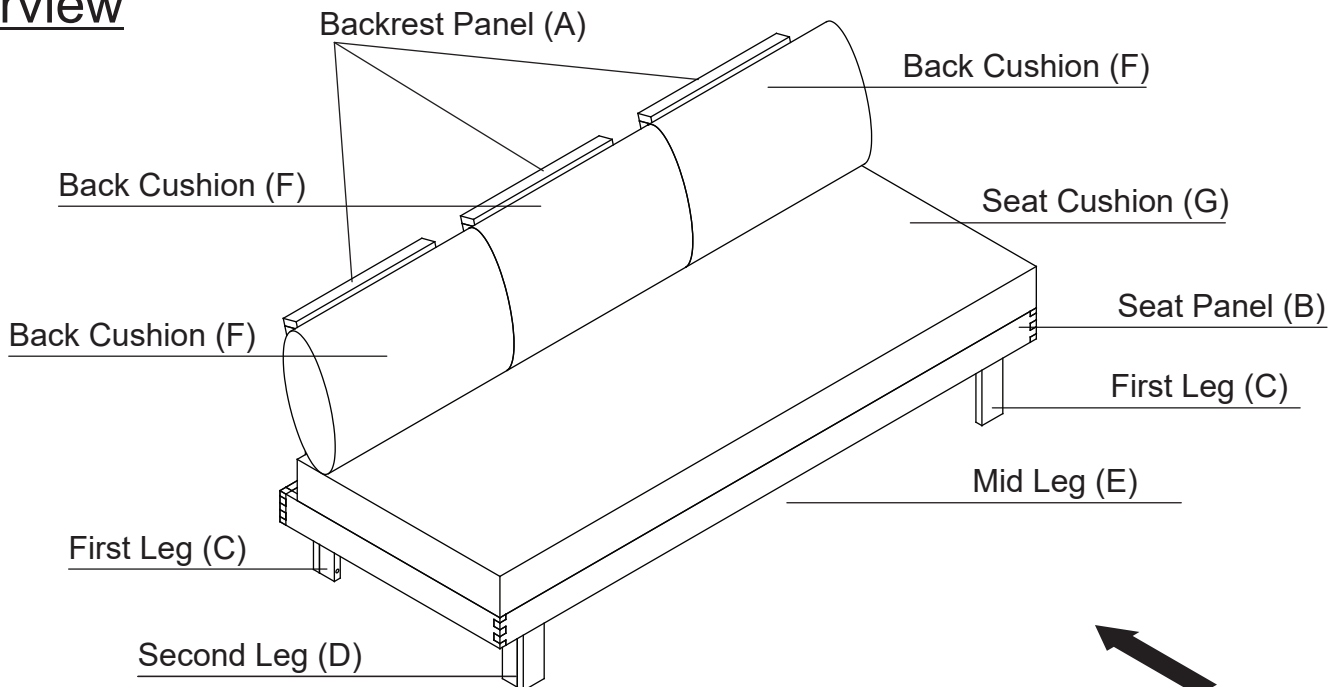

FRONT FACING

This Sofa has multiple parts and may require up to 30 minutes to assemble. To give you an overview of the Sofa parts, the above picture is to help you put the various parts into perspective. Please read through the instructions below to familiarise yourself with the parts and steps before assembly.

Step 1

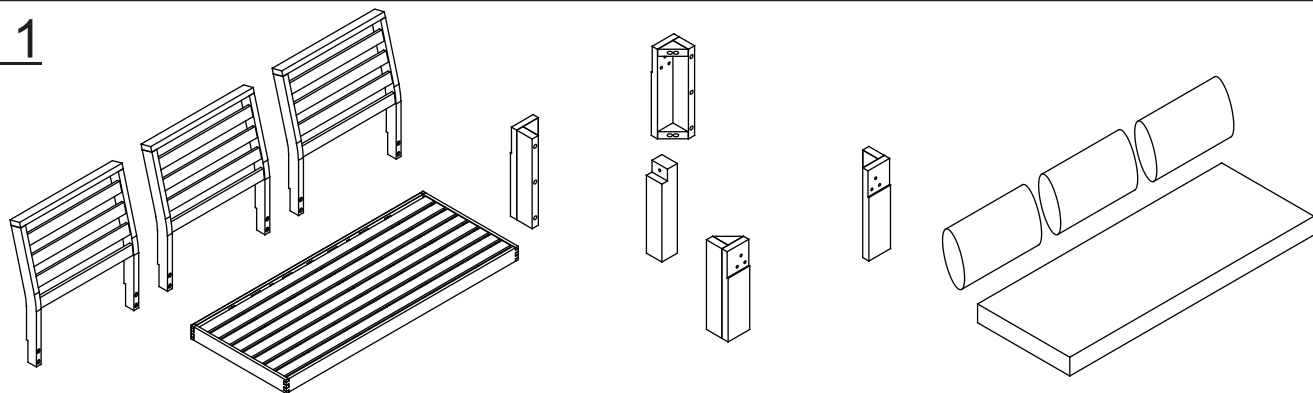

Unpack and place all parts on a clean, non-marring surface.

Step 2

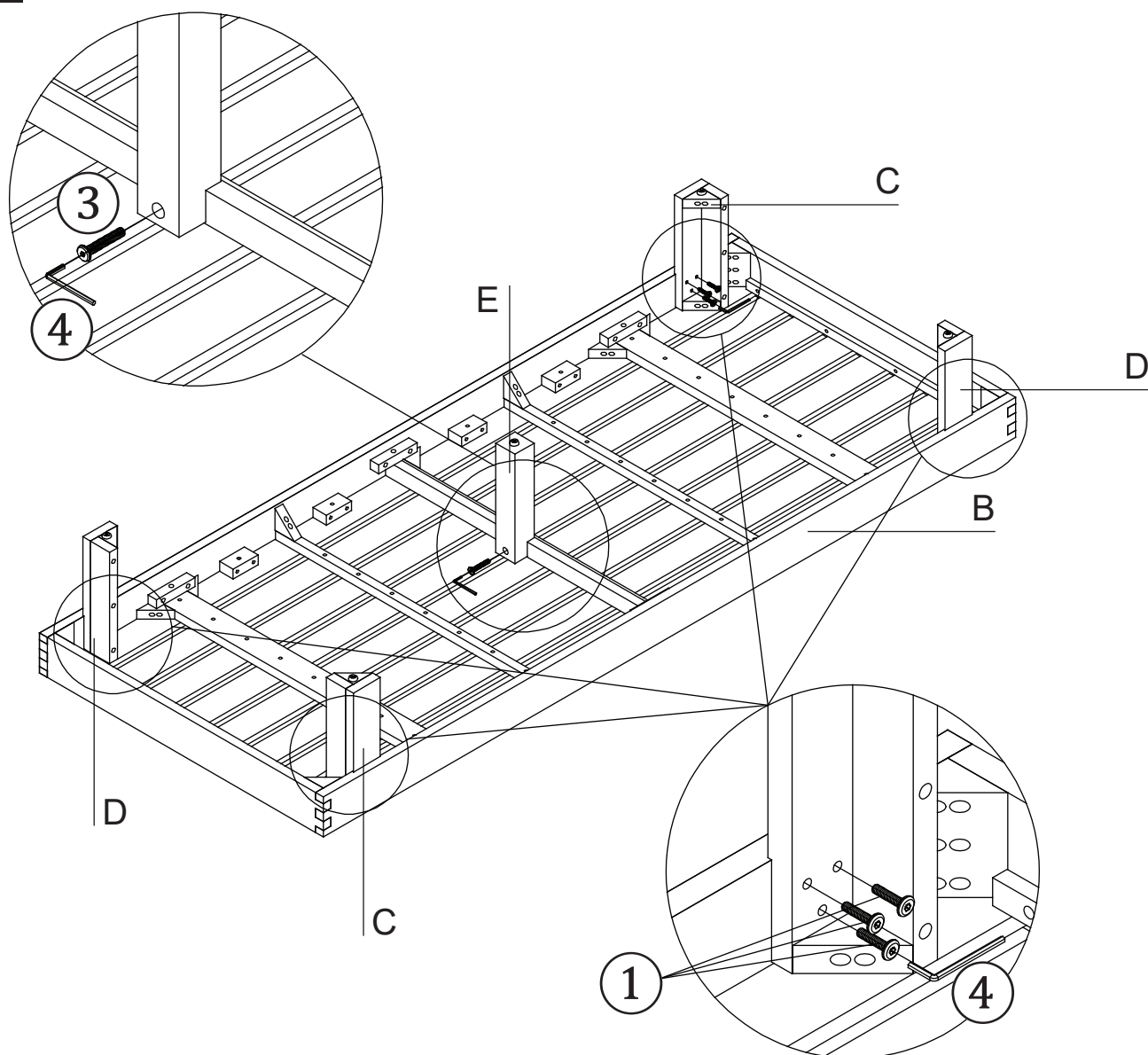

Place the Seat Panel (B) facedown on a clean, non-marring surface. With assistance from your adult partners, attach the First Leg (C), Second Leg (D), Mid Leg (E) to the Seat Panel (B) using Bolts (1), Bolts (3) and the Allen Wrench (4) as shown above.

Do not fully tighten Bolts.

Step 3

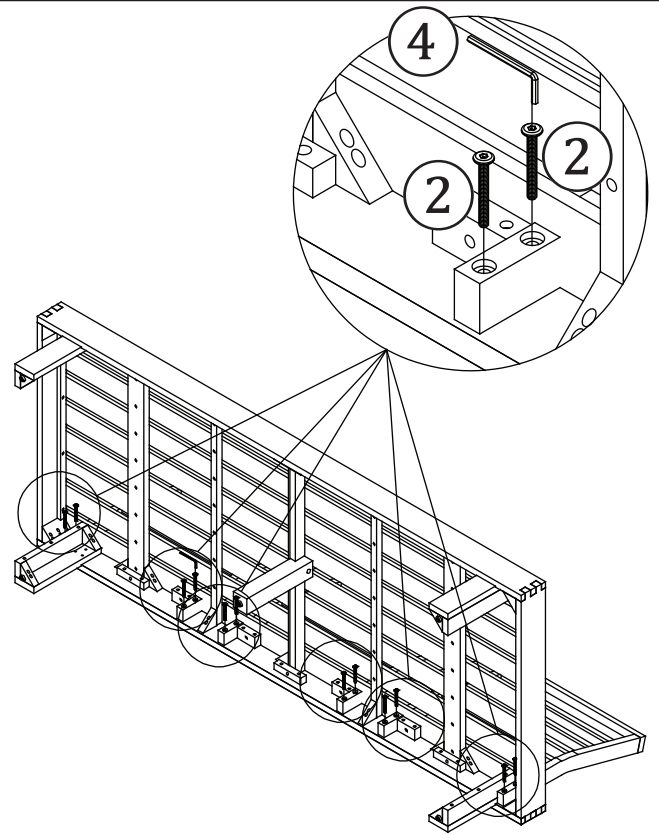
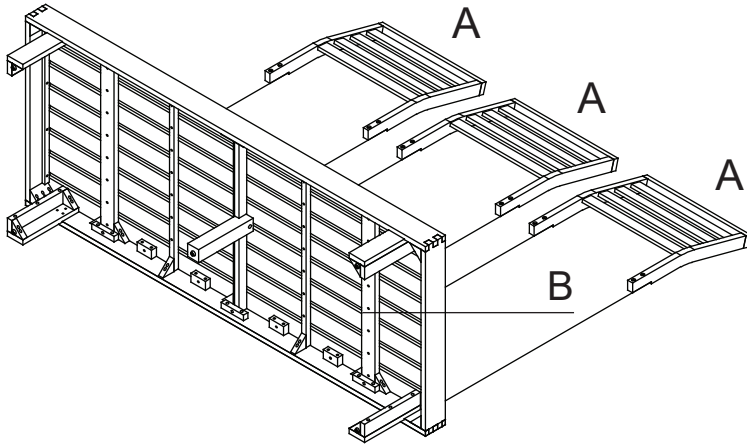

With the help of your adult partner, attach the Backrest Panel (A) to Step 2 using Bolts ② and the Allen Wrench ④ as show above.
Do not fully tighten the Bolts.

Step 4

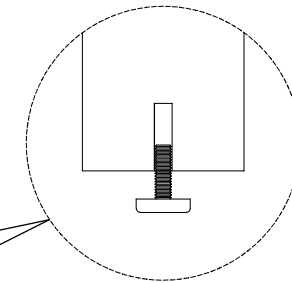
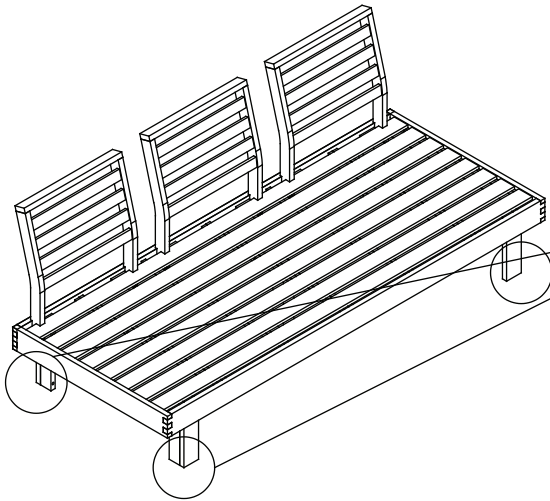

Adjust height for balance

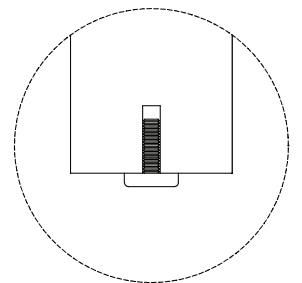

Adjust low for balance

Adjust Pre-installed
Levelers height for balance

Turn the Sofa right side up.
Place the Sofa on a **LEVEL SURFACE**.
Inspect it and make sure all parts are adequately connected.
Press on the Sofa with both hands and apply pressure towards the floor.
This would help the Sofa reach full alignment at all joints.
Check for wobbles.
In a sequential manner, proceed to tighten all bolts.

CAUTION: When tightening these bolts, tighten sequentially.
DO NOT tighten any bolts fully and then towards the next one.
This would cause the frame to warp.
If there is still wobbles, loosen the bolts and execute this same process.
Ensure all botls are fully locked into position.

Step 5

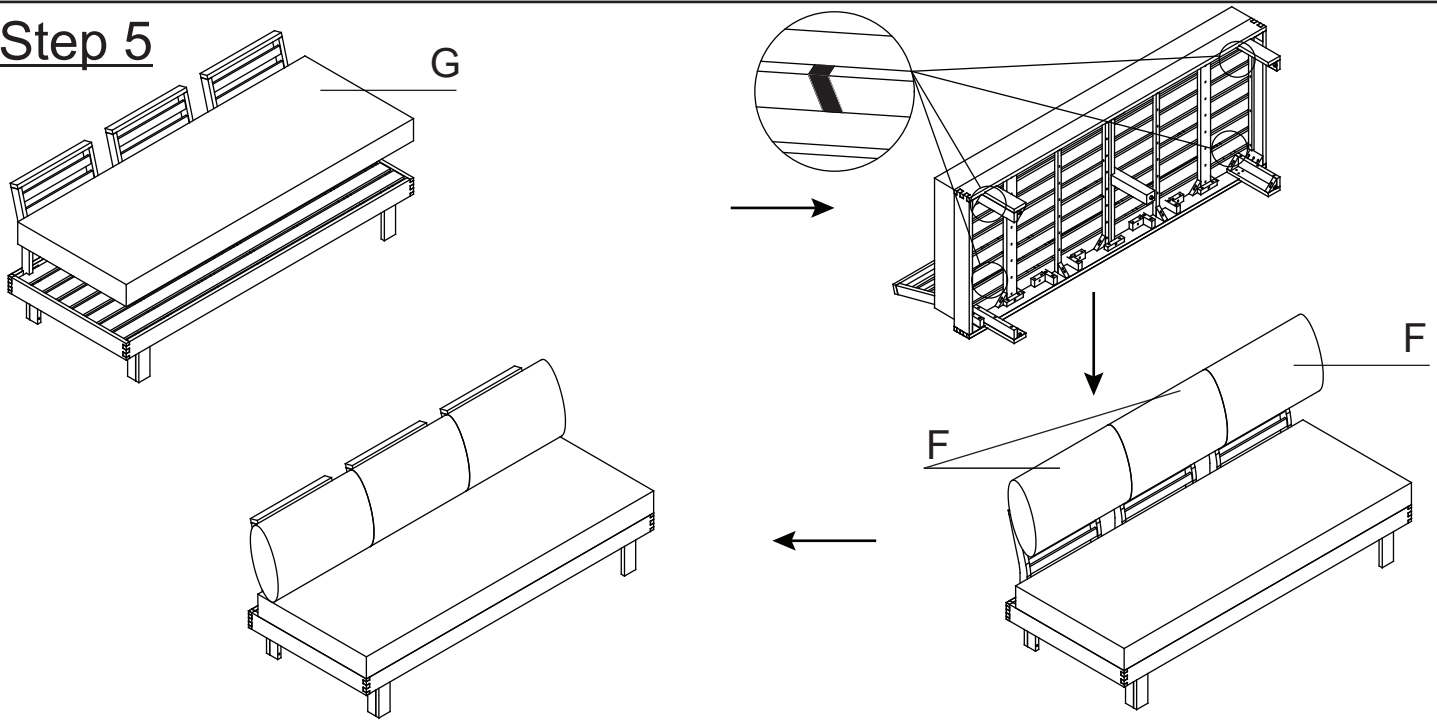

Place the Seat Cushion (G) and the Back Cushion (F) on the Seat Panel (B).
With the help of your adult partner, turn the Sofa right side up.
Tie the magic tape straps on the Seat Cushion (G) to the Seat Panel (B) as show above.
Inspect it and make sure all parts are adequately connected.
Ensure all bolts are fully locked into position and secured.

The Sofa is ready to be used.

Caution: This Sofa can only be used on a flat, level surface.

Questions & Answers about Proposition 65

• What is Proposition 65?

Proposition 65 requires businesses to provide warnings to Californians about significant exposures to chemicals that cause cancer, birth defects or other reproductive harm. These chemicals can be in the products that Californians purchase, in their homes or workplaces, or that are released into the environment. By requiring that this information be provided, Proposition 65 enables Californians to make informed decisions about their exposures to these chemicals.

Proposition 65 also prohibits California businesses from knowingly discharging significant amounts of listed chemicals into sources of drinking water.

Proposition 65 requires California to publish a list of chemicals known to cause cancer, birth defects or other reproductive harm. This list, which must be updated at least once a year, has grown to include approximately 900 chemicals since it was first published in 1987.

• What types of chemicals are on the Proposition 65 list?

The list contains a wide range of naturally occurring and synthetic chemicals that include additives or ingredients in pesticides, common household products, food, drugs, dyes, or solvents. Listed chemicals may also be used in manufacturing and construction, or they may be byproducts of chemical processes, such as motor vehicle exhaust.

• What does a warning mean?

If a warning is placed on a product label or posted or distributed at a workplace, a business, or in rental housing, the business issuing the warning is aware or believes that it is exposing individuals to one or more listed chemicals.

By law, a warning must be given for listed chemicals unless the exposure is low enough to pose no significant risk of cancer or is significantly below levels observed to cause birth defects or other reproductive harm.

• Where can I get more information on Proposition 65?

If you have specific questions on the administration or implementation of Proposition 65, you can contact OEHHA's Proposition 65 program at P65.Questions@oehha.ca.gov, or by phone at (916) 445-6900.