

# INSTALLATION & ASSEMBLY

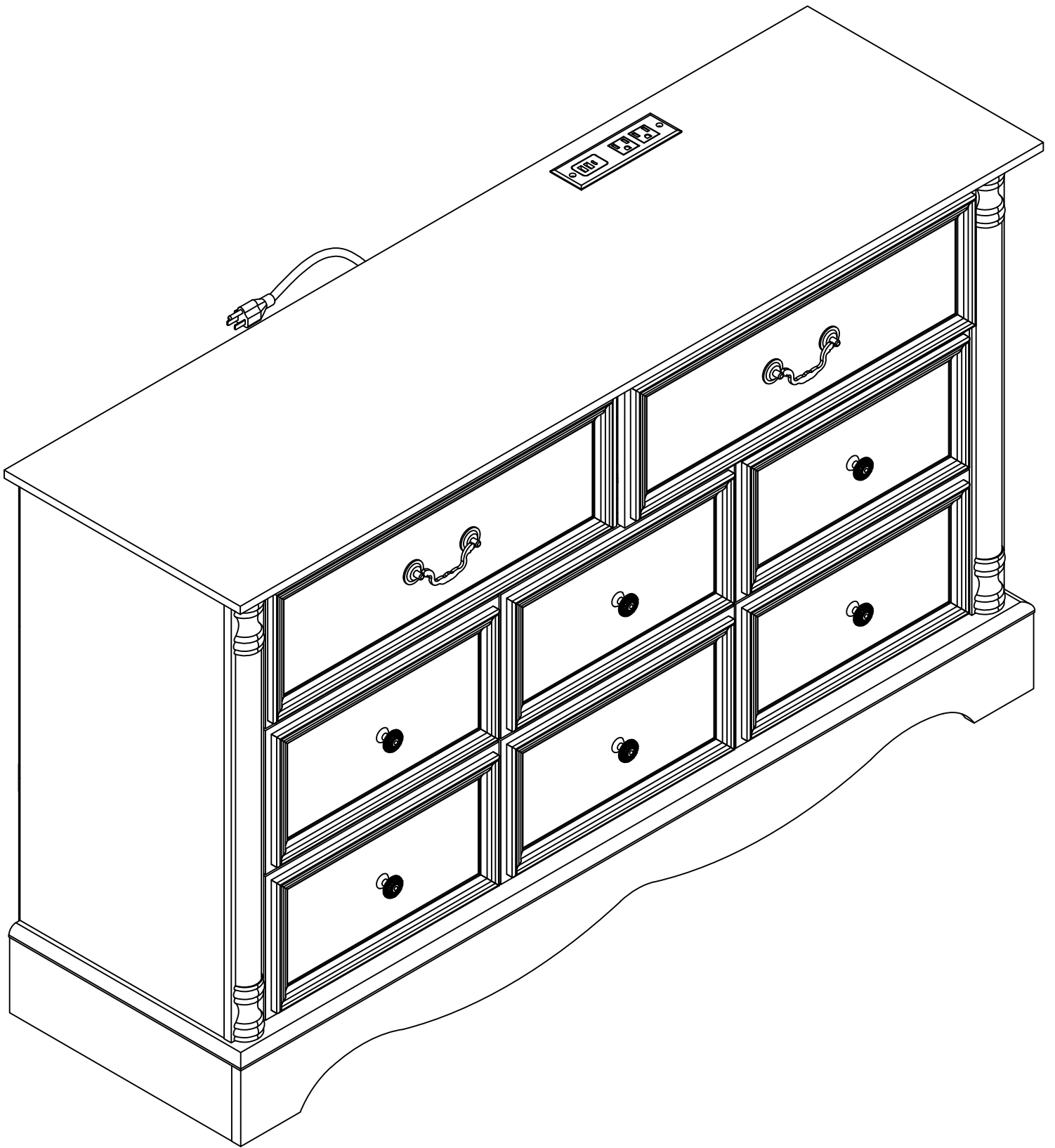

# General Assembly Guidelines

- I. Please ensure that all parts and hardware are available before assembly.
- II. Follow each step carefully to ensure the proper assembly of this product.
- III. For easy of assembly, two people are recommended to assemble this product.
- IV. The three main types of hardware are: wood dowels , screws and bolts.

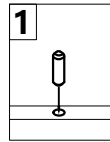

V. A Phillips head screwdriver is required for the assembly of this product.

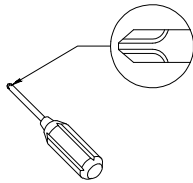

VI. Power tools should not be used when assemble this product.

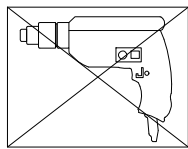

VII. Steps for assembly of three-in-one screws.

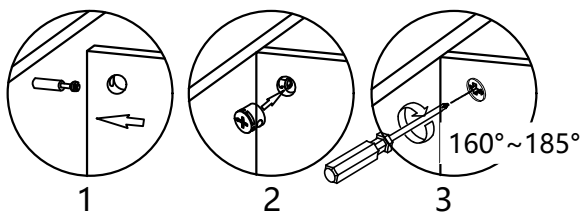

IX. Screw fixation diagram for all fittings

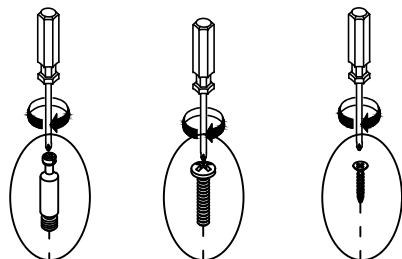

# Parts List

- ① x 1
- ② x 1
- ③ x 1
- ④ x 1
- ⑤ x 2
- ⑥ x 2
- ⑦ x 1
- ⑧ x 1
- ⑨ x 1
- ⑩ x 2
- ⑪ x 1
- ⑫ x 1
- ⑬ x 1
- ⑭ x 1
- ⑮ x 8
- ⑯ x 8
- ⑰ x 6
- ⑱ x 6
- ⑲ x 2
- ⑳ x 2
- ㉑ x 2
- ㉒ x 2
- ㉓ x 2
- ㉔ x 2
- ㉕ x 1
- ㉖ x 1
- ㉗ x 1
- ㉘ x 1
- ㉙ x 1
- ㉚ x 1

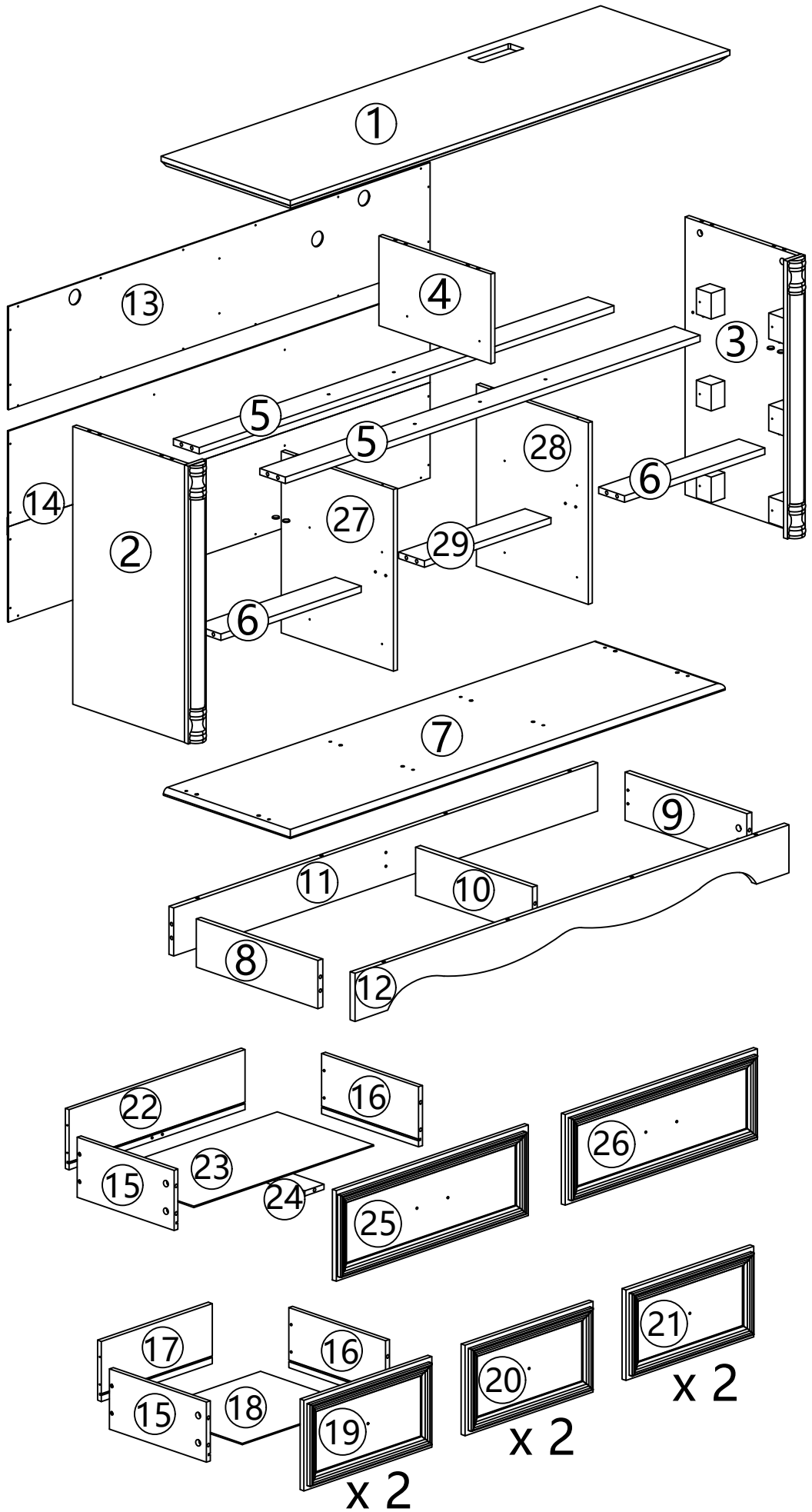

# HARDWARE

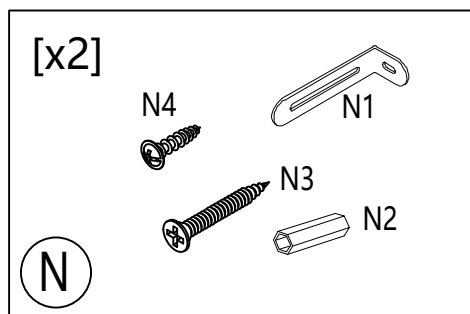
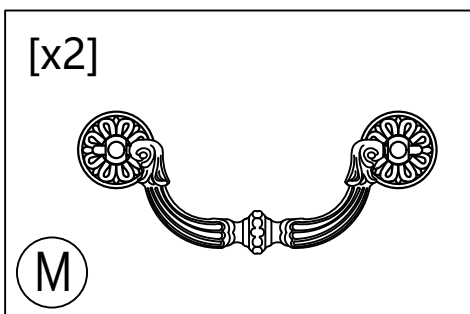
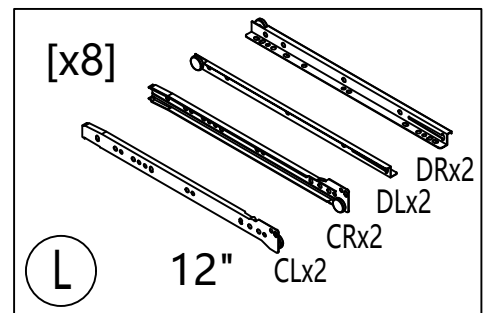
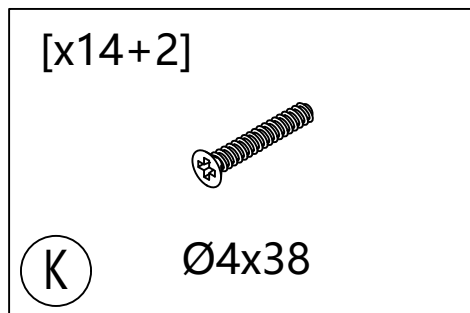
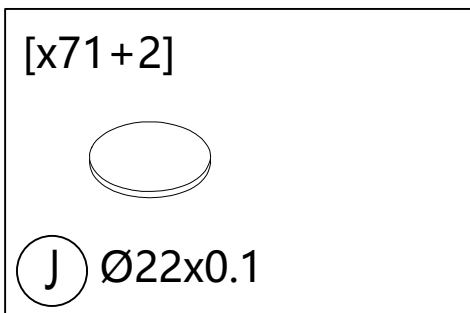
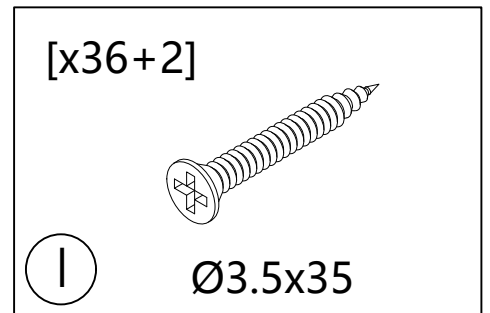
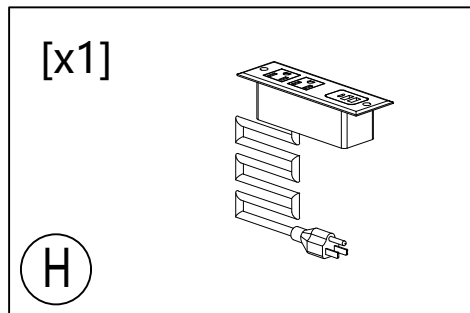
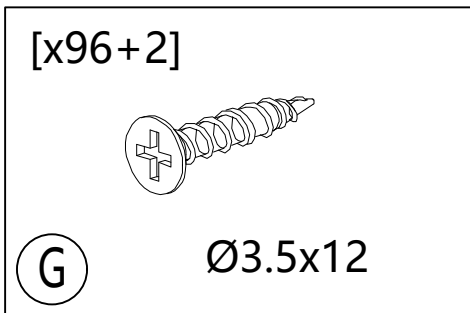
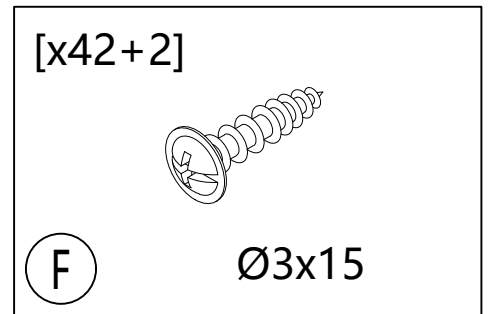
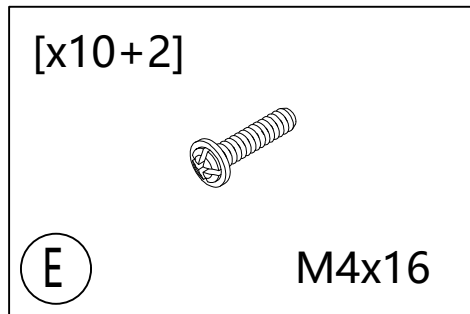
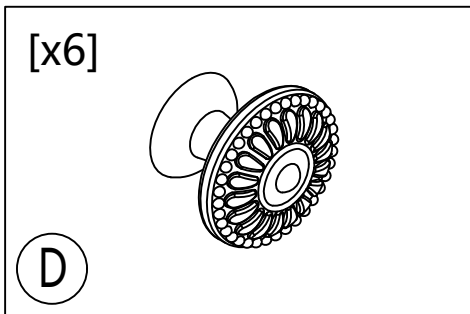
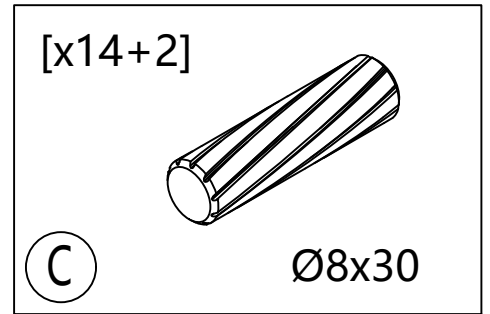
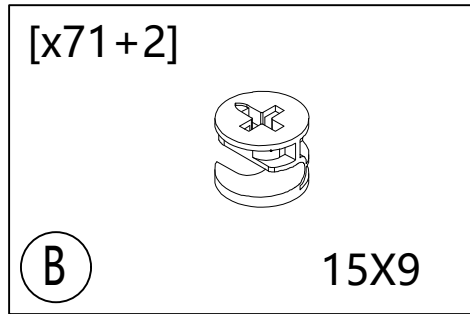
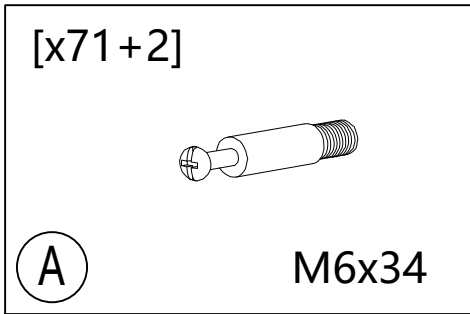

## STEP#1



G x 12



L x 3

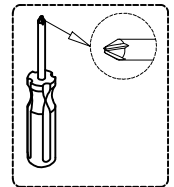
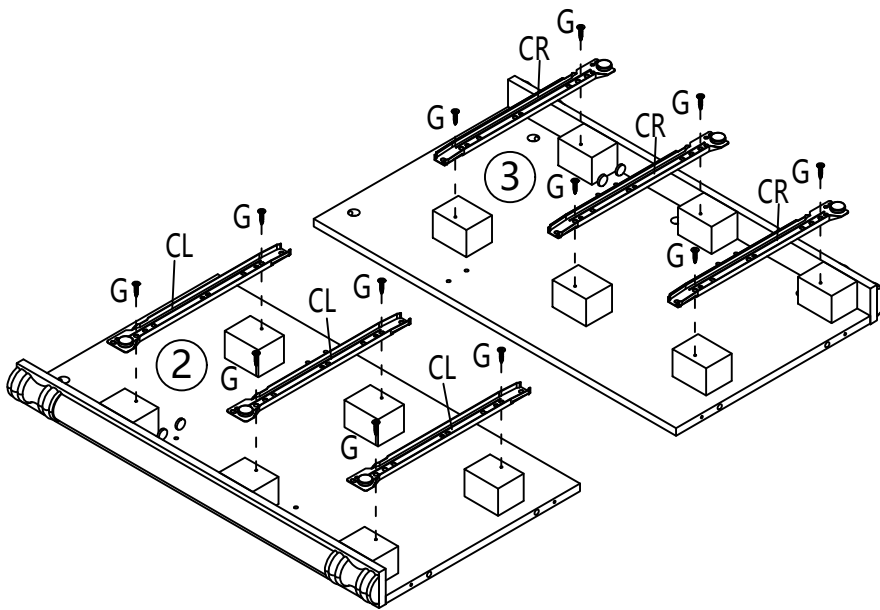

## STEP#2



A x 12

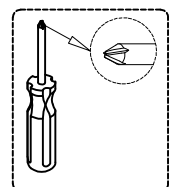
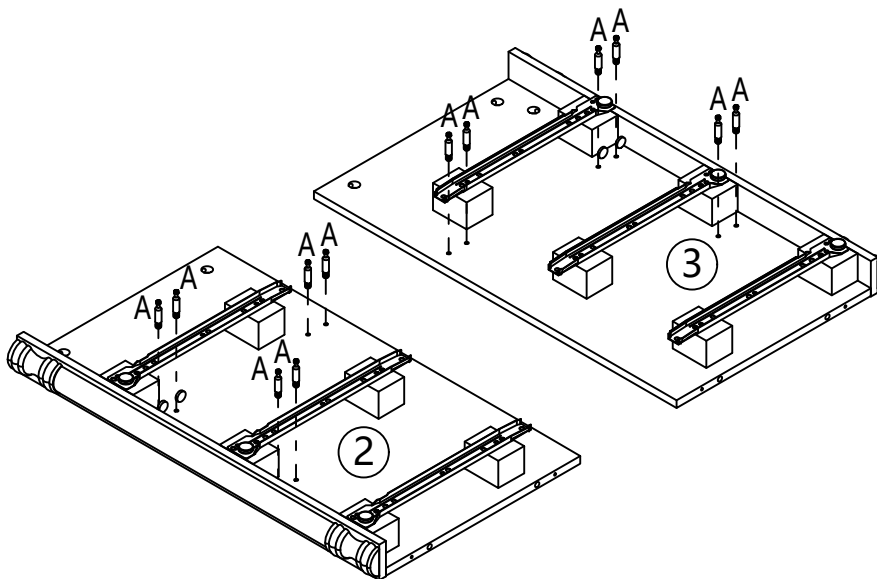

### STEP#3

G x 16

CR  
CL

L x 4

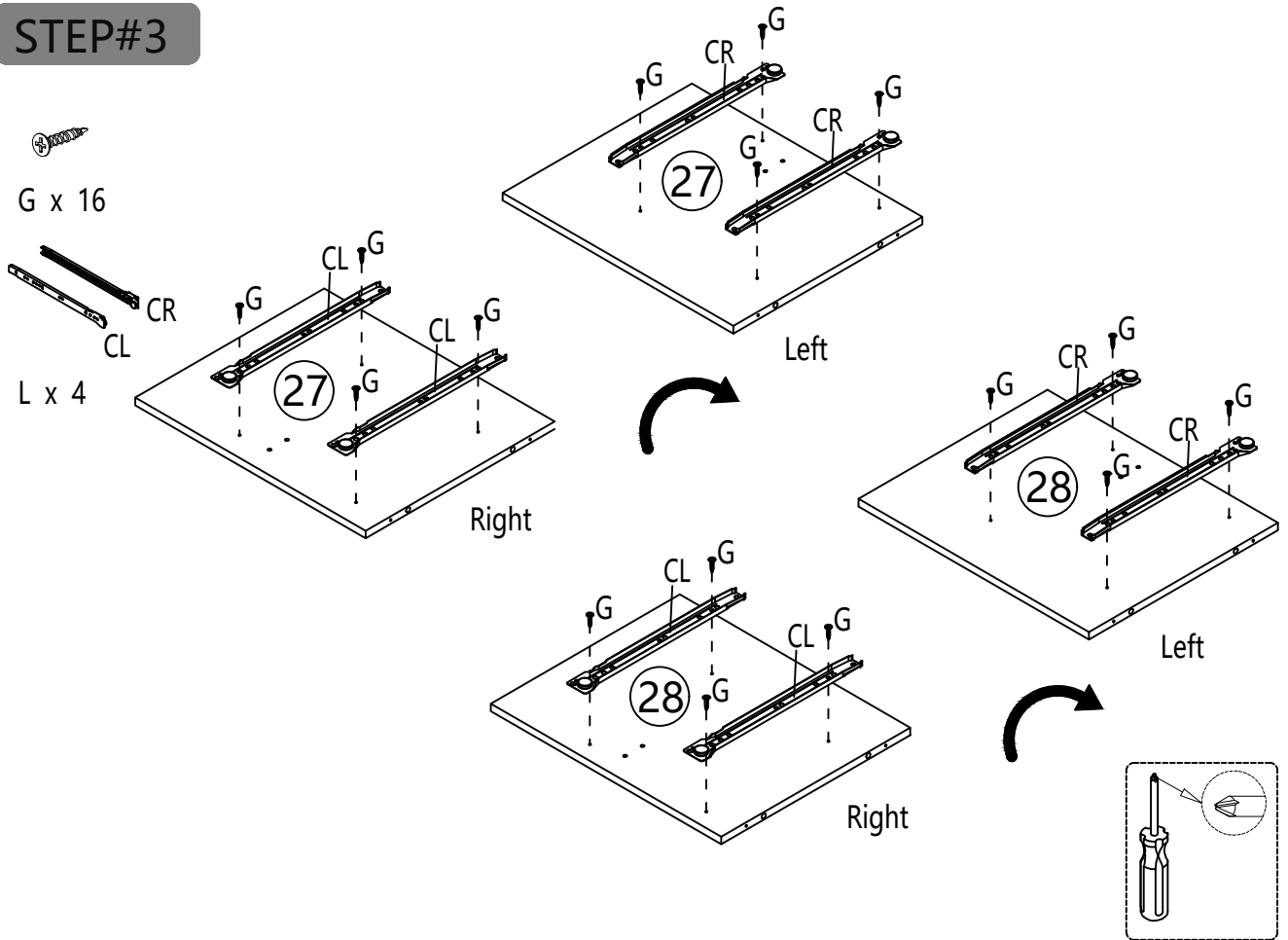

### STEP#4

A x 8

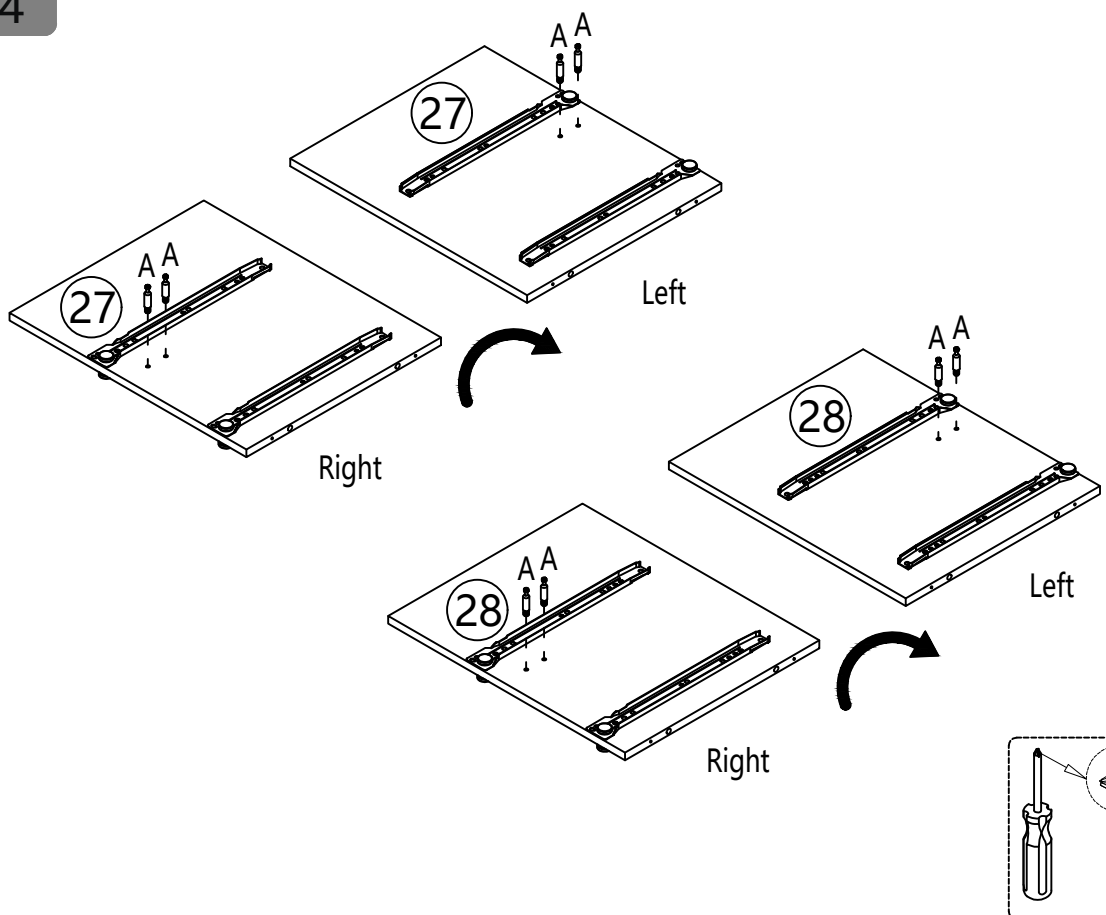

# STEP#5



G x 4



L x 1

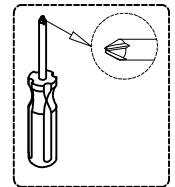
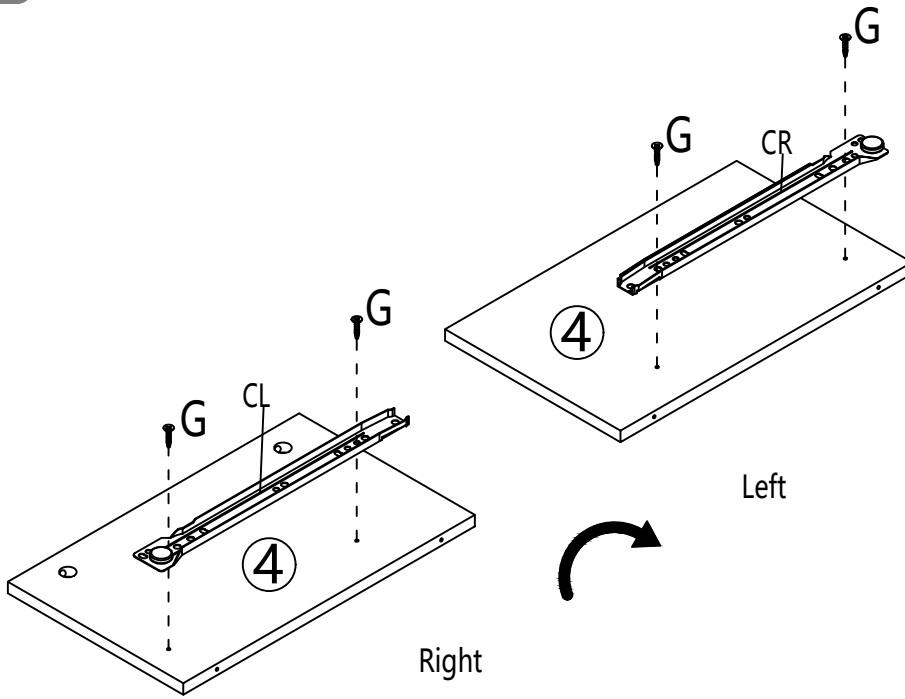

# STEP#6



B x 4



J x 4

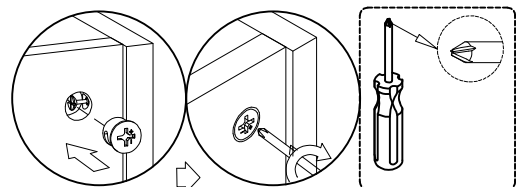
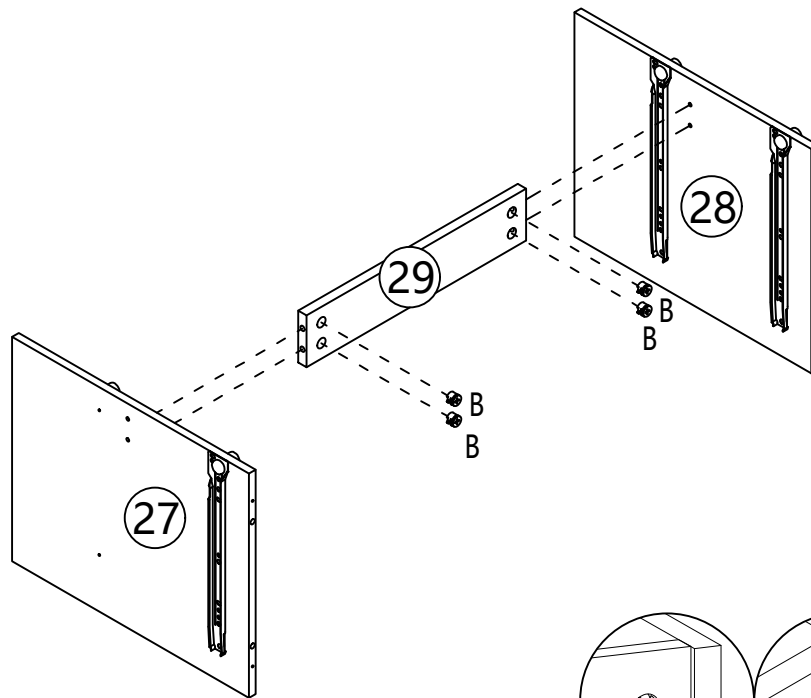

# STEP#7



K x 4

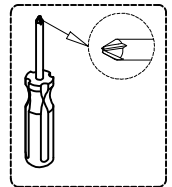
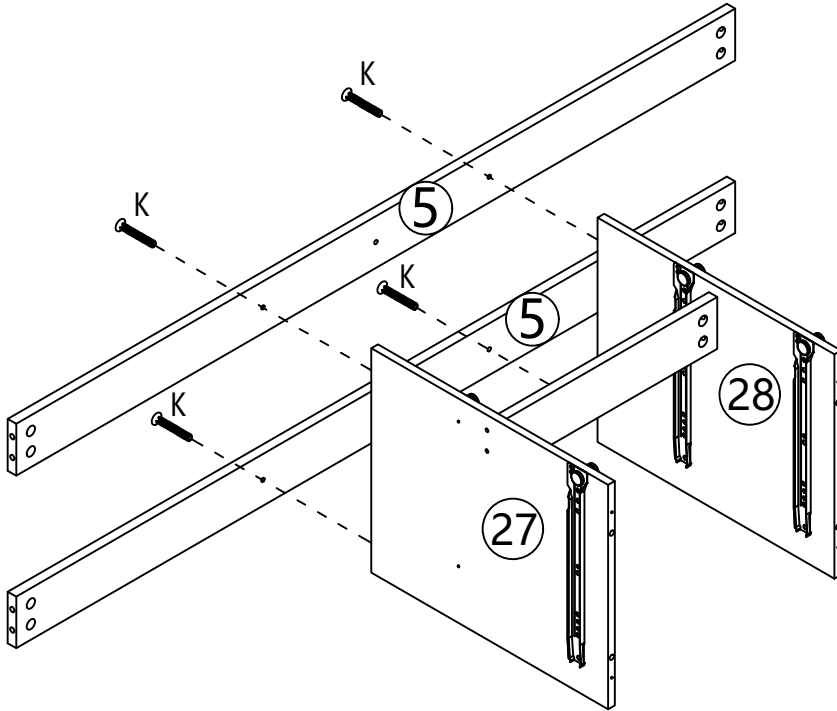

# STEP#8



K x 2

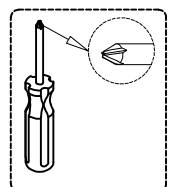
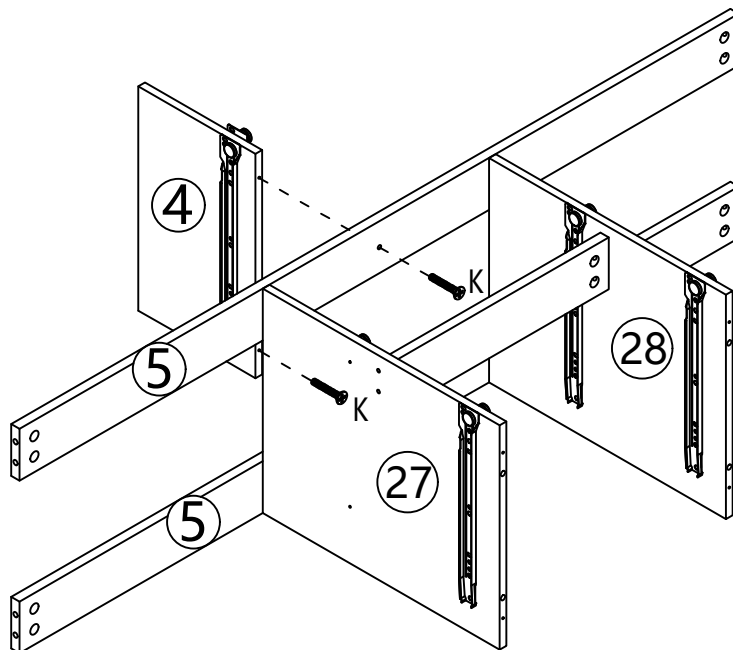

# STEP#9



B x 8



J x 8

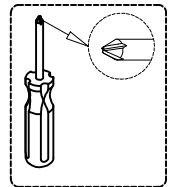
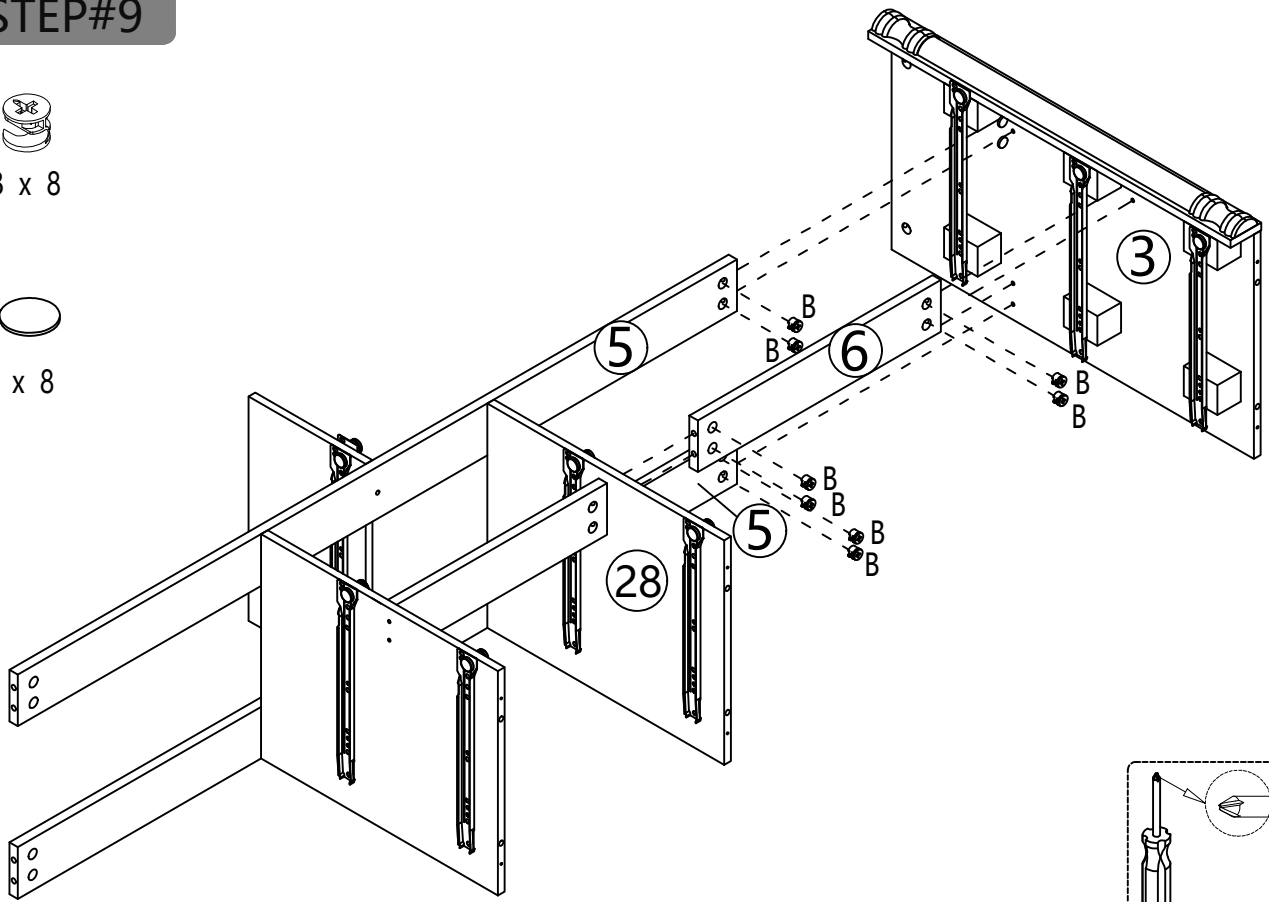

# STEP#10



B x 8



J x 8

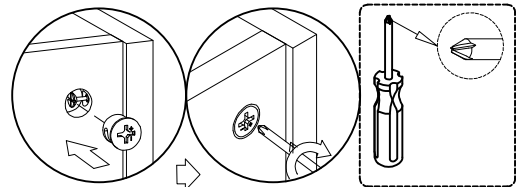
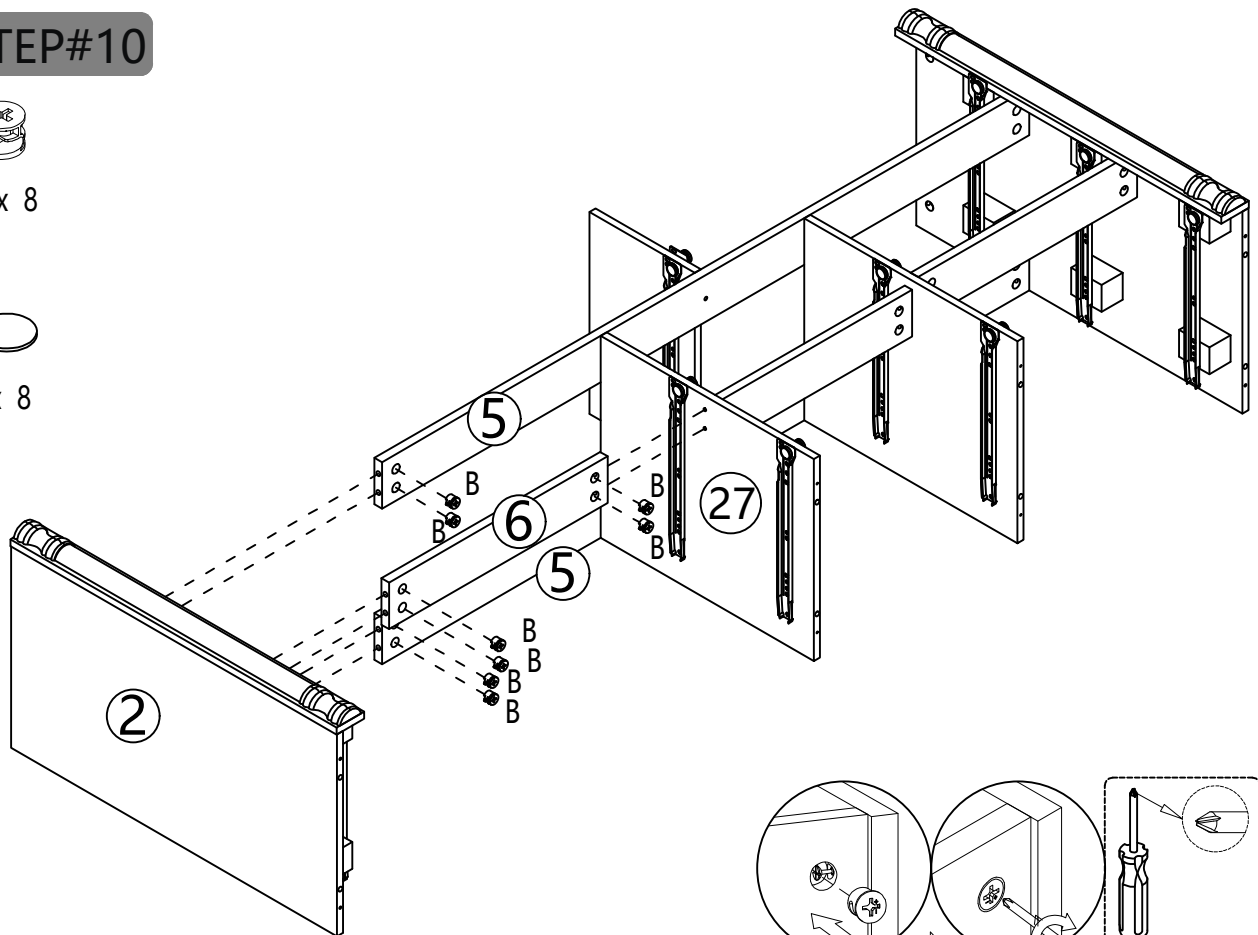

# STEP#11



K x 8



C x 8

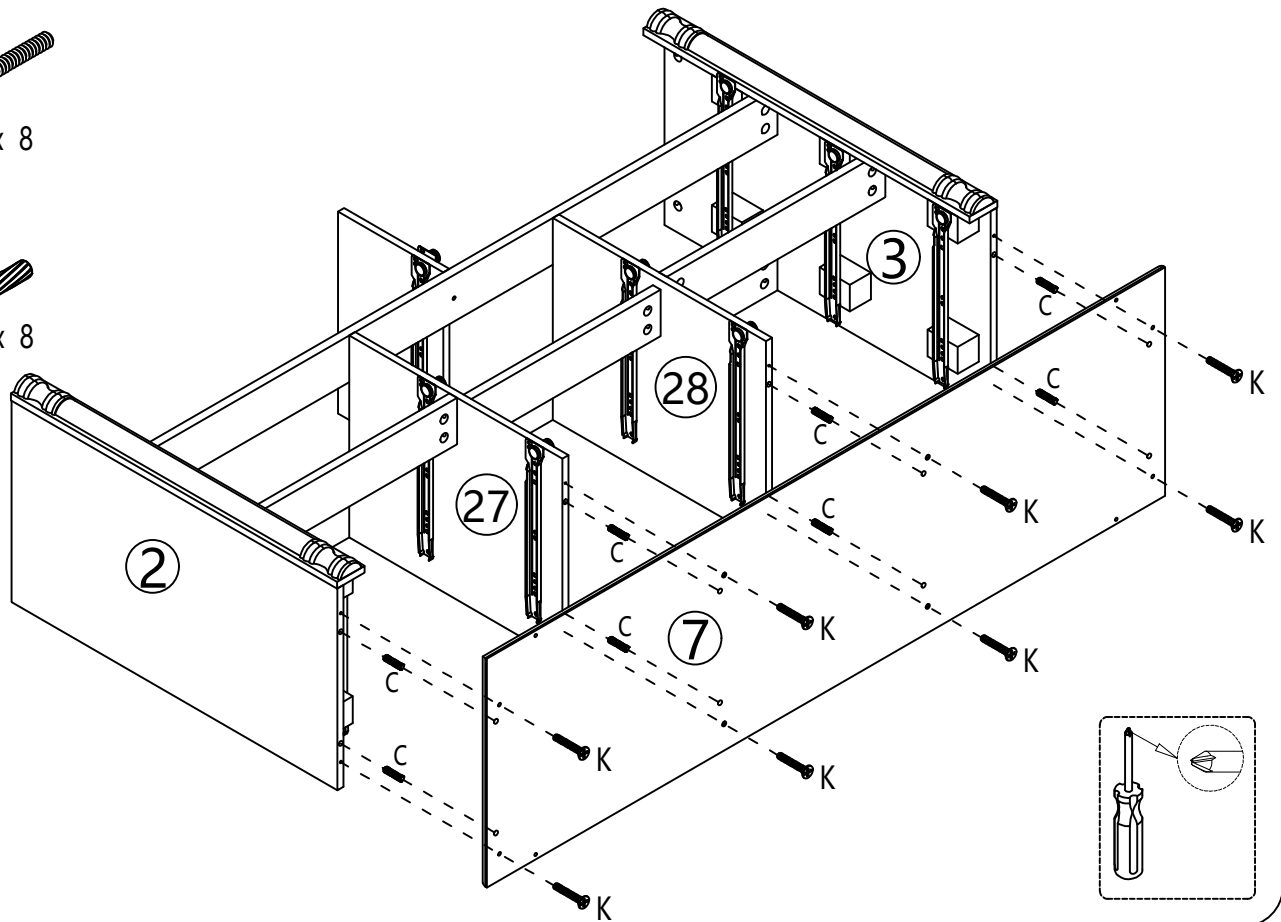

# STEP#12



A x 8

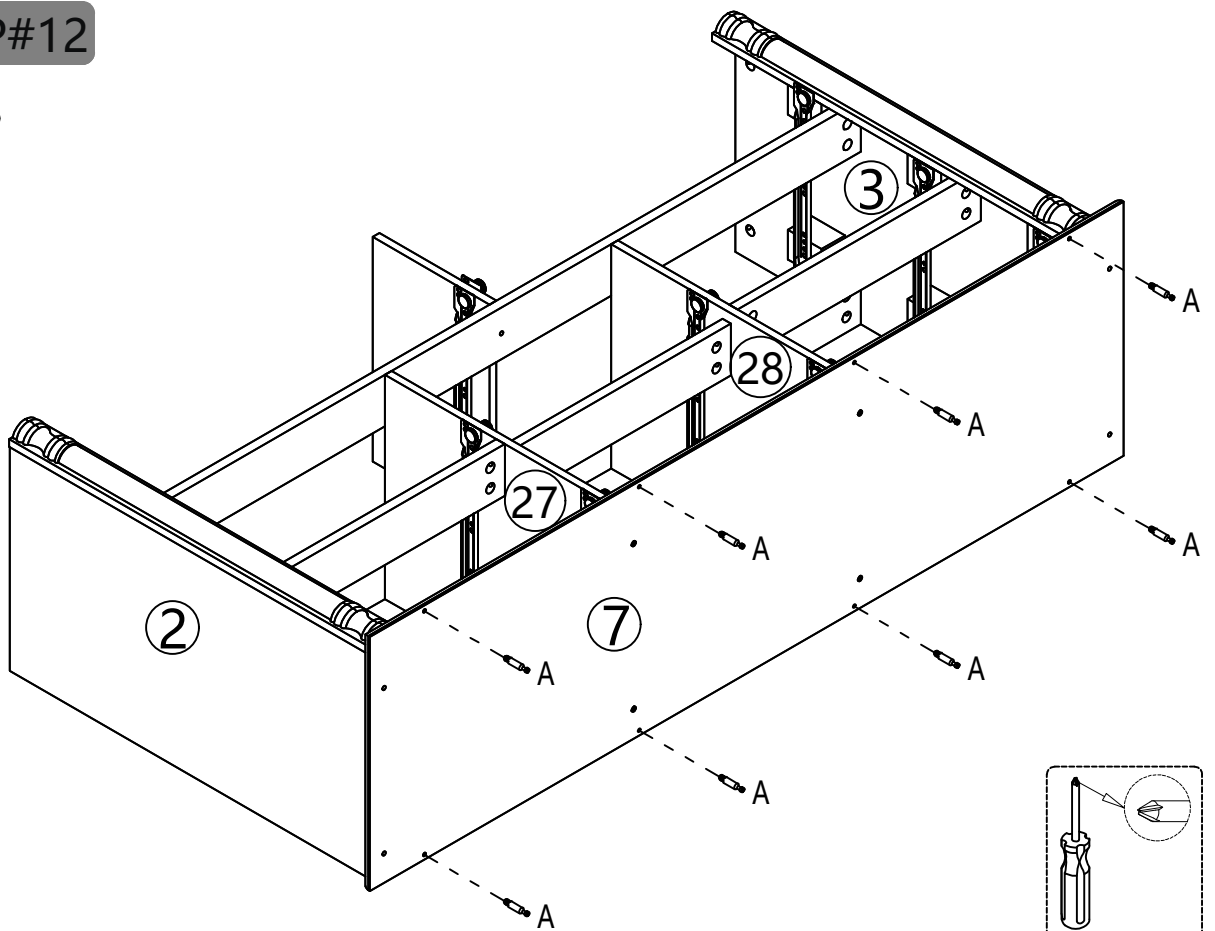

# STEP#13



A x 11

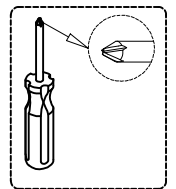
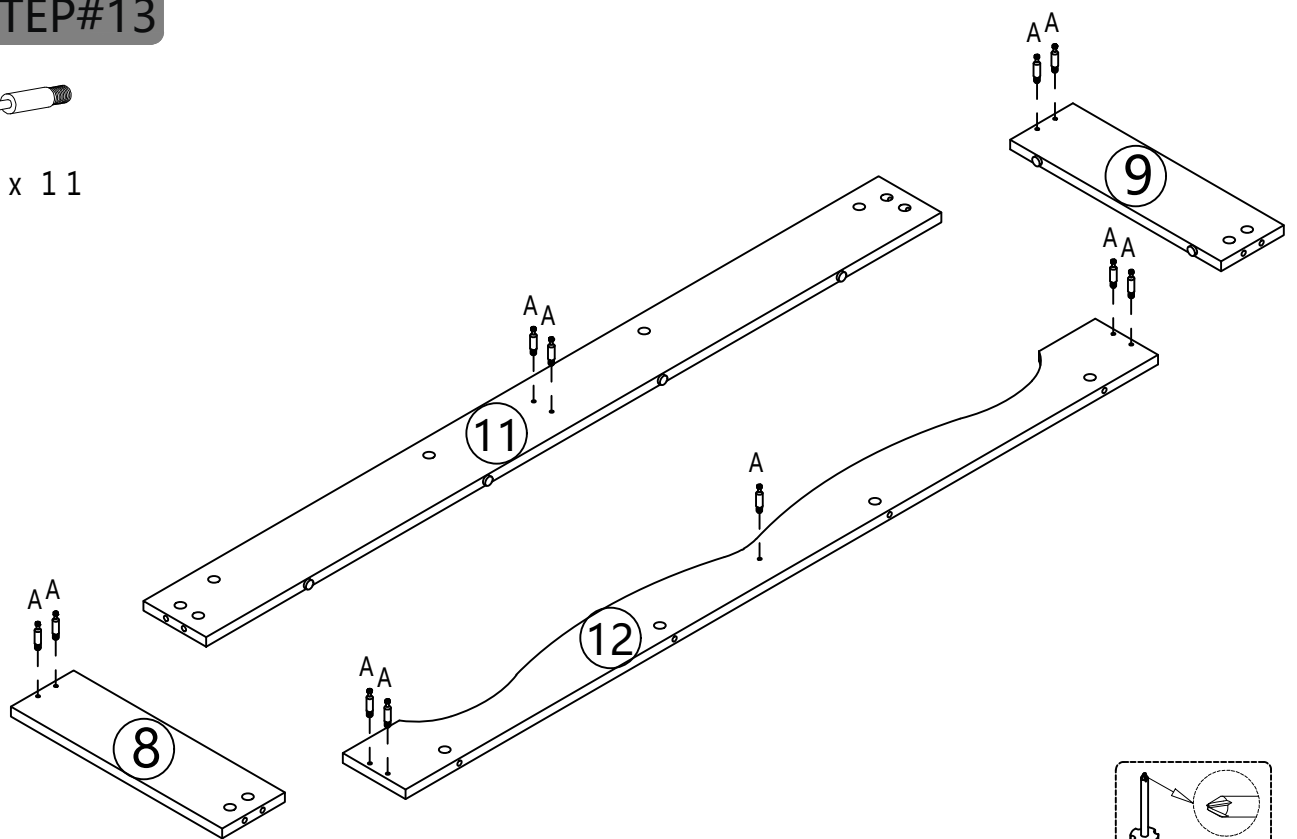

# STEP#14



B x 6



J x 6

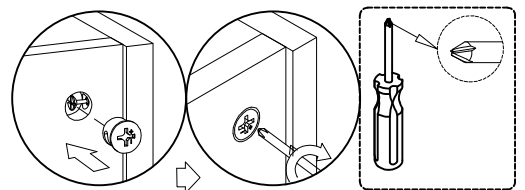
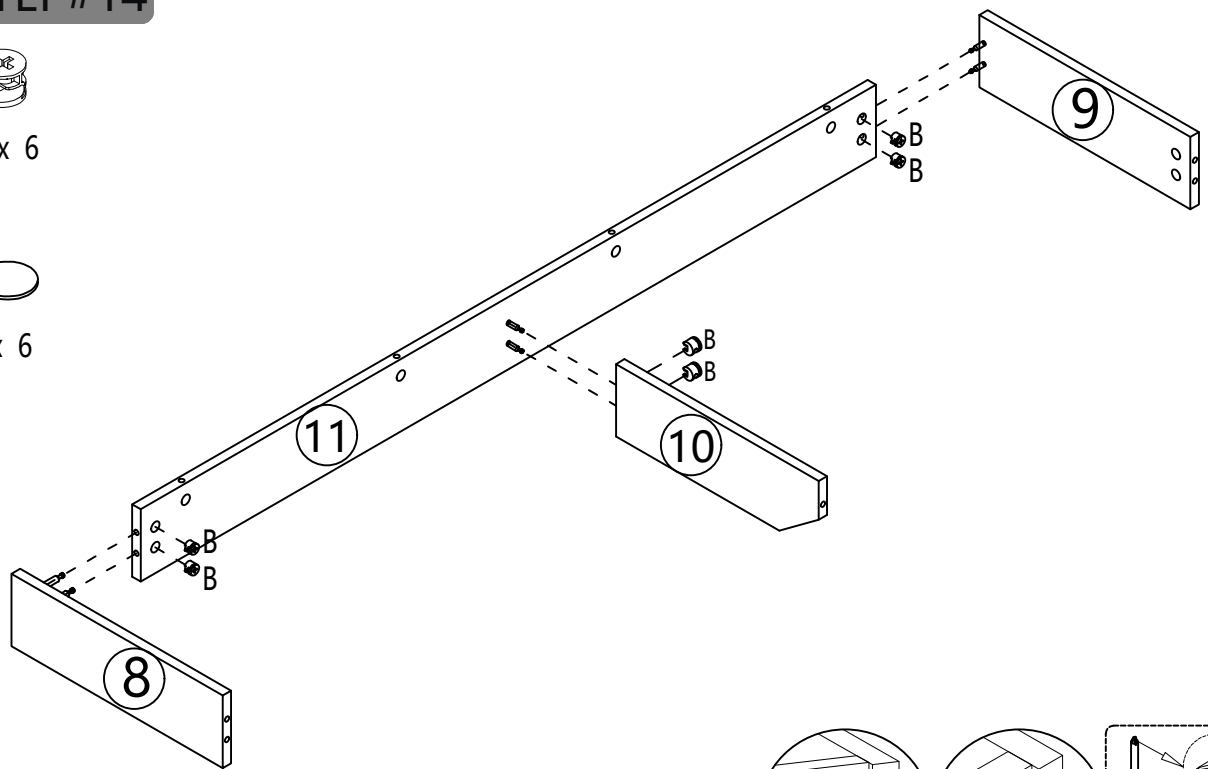

# STEP#15



B x 5



J x 5

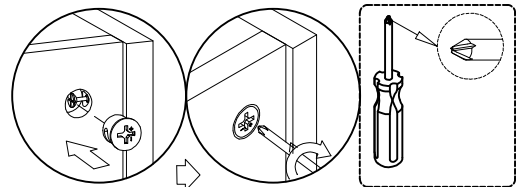
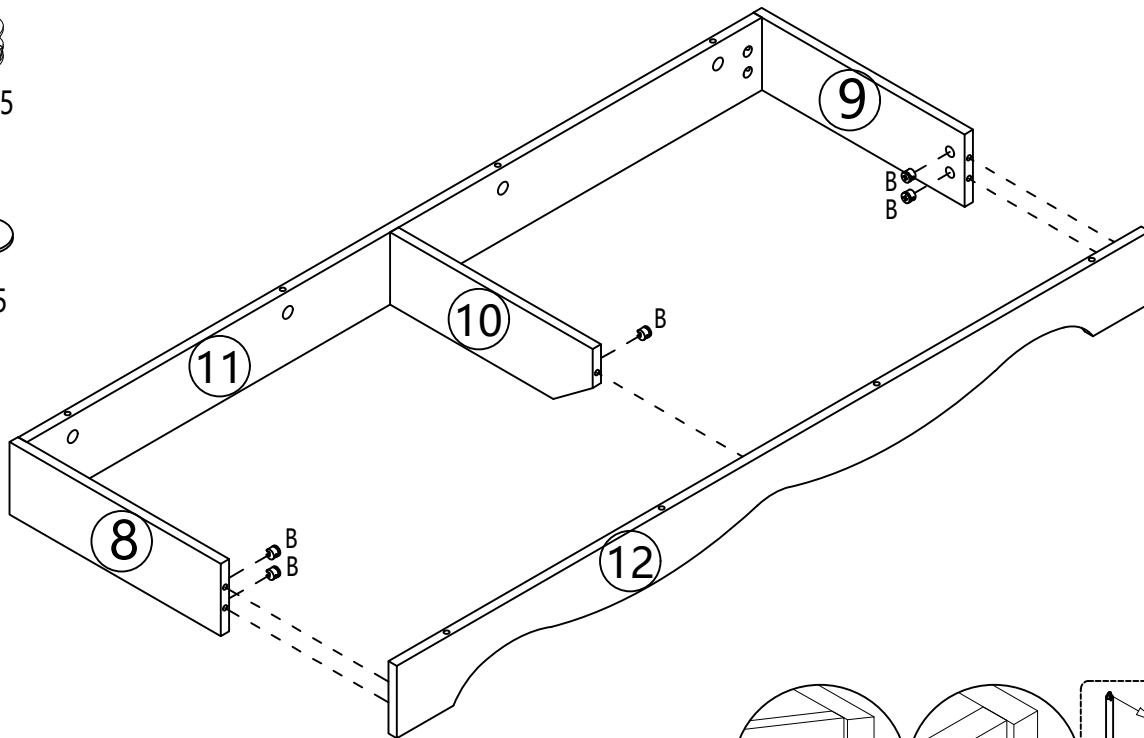

# STEP#16



B x 8



J x 8

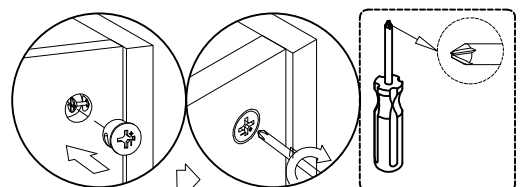
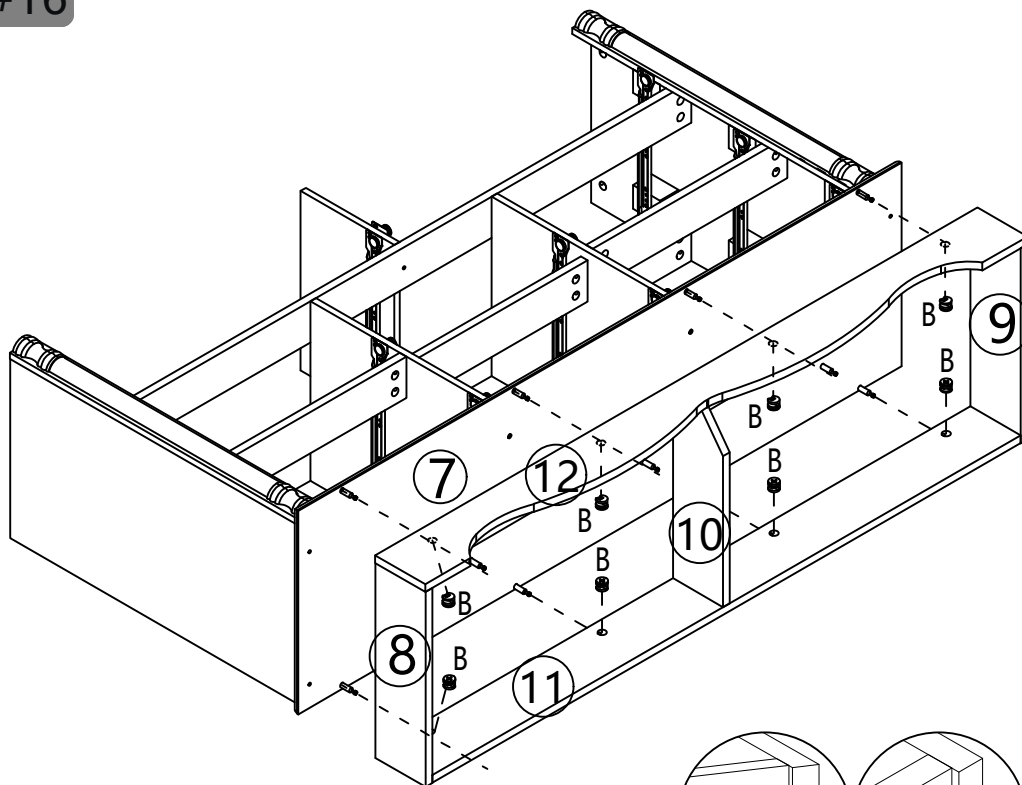

# STEP#17



A x 6

N4



N1

N x 2

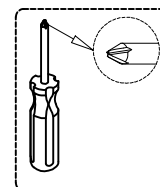
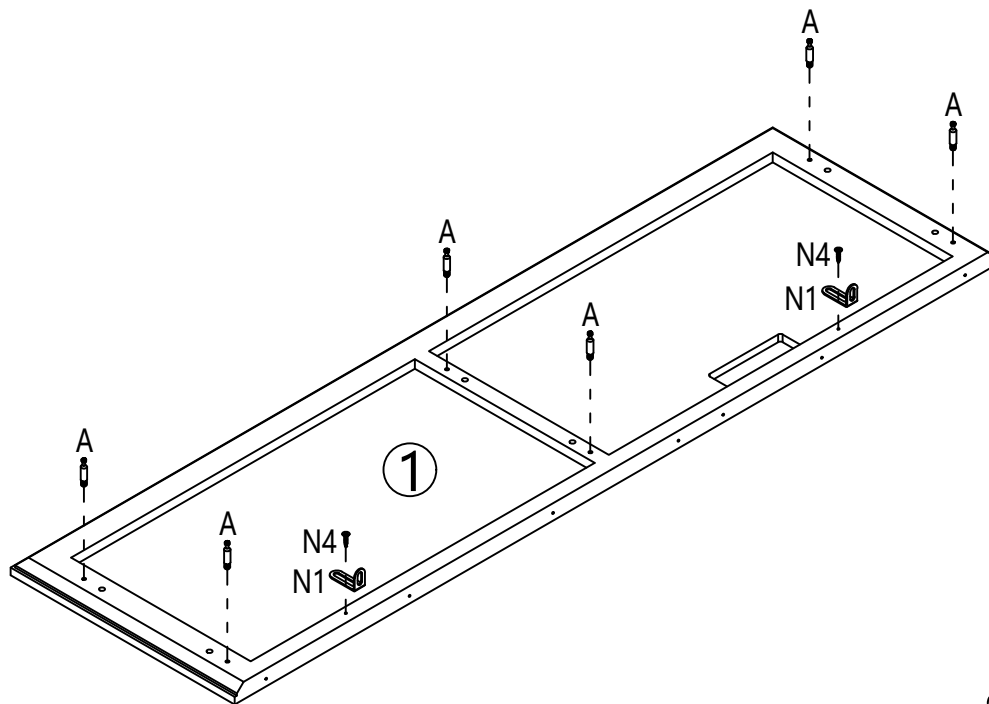

# STEP#18



B x 6



C x 6

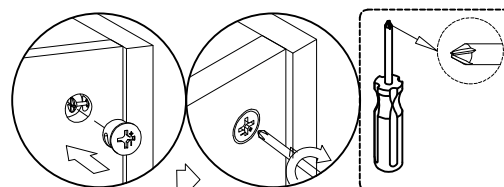
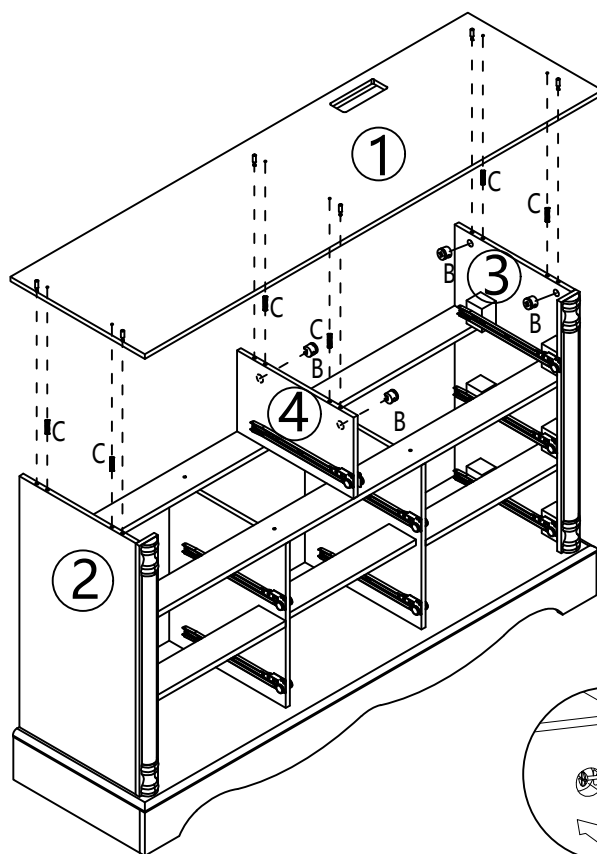

# STEP#19



F x 40

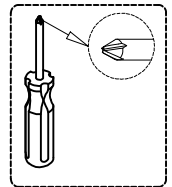
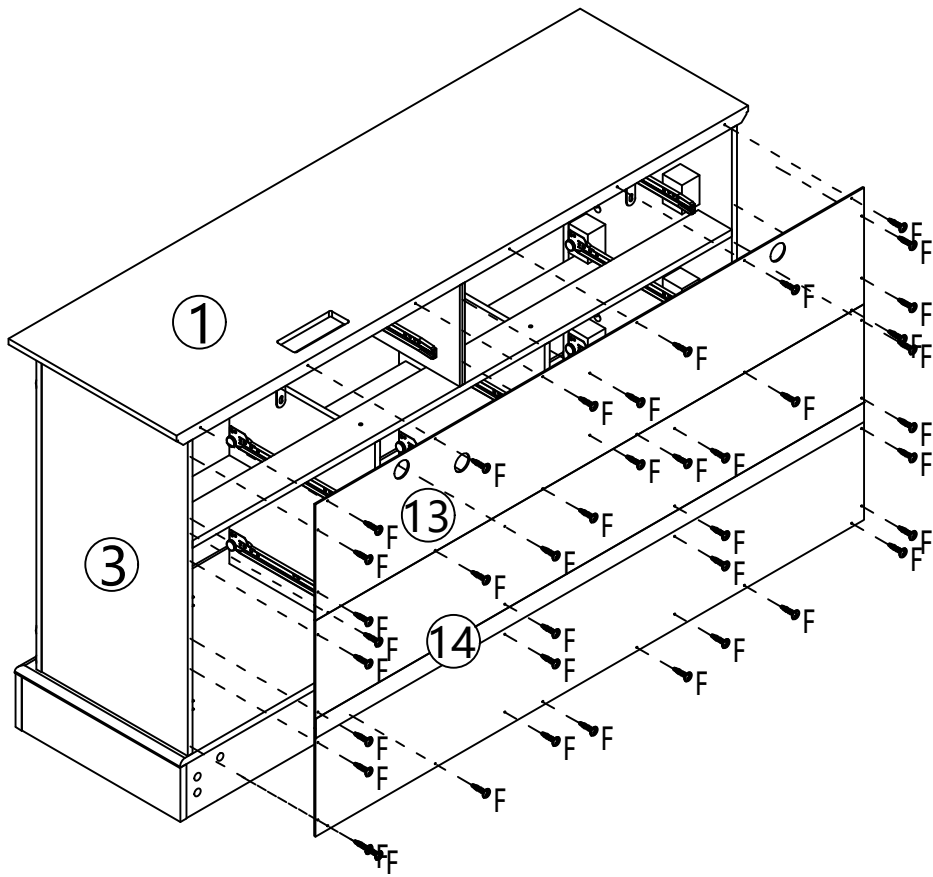

# STEP#20



F x 2

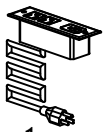

H x 1

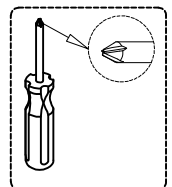
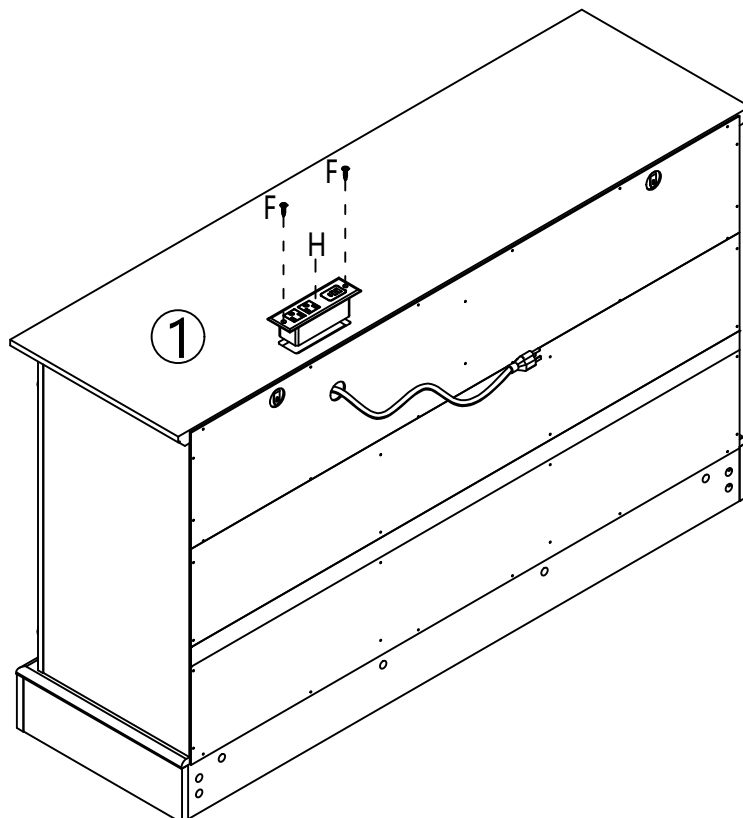

### STEP#21

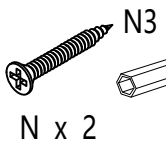

N2

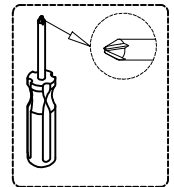
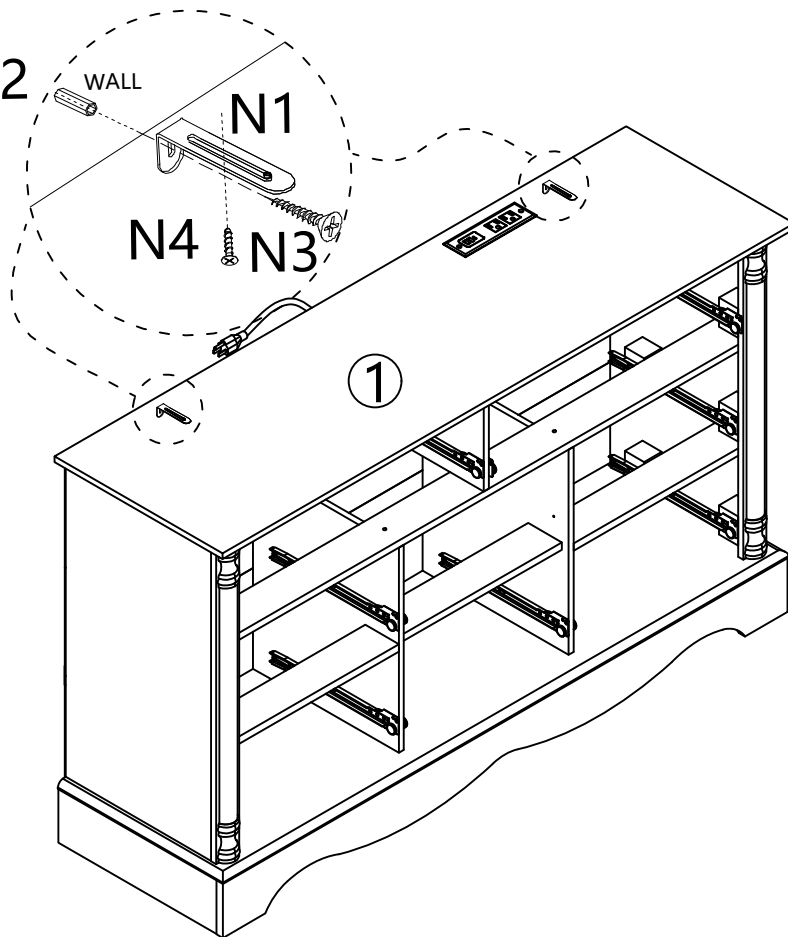

### STEP#22

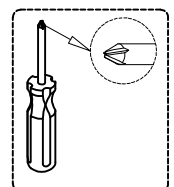
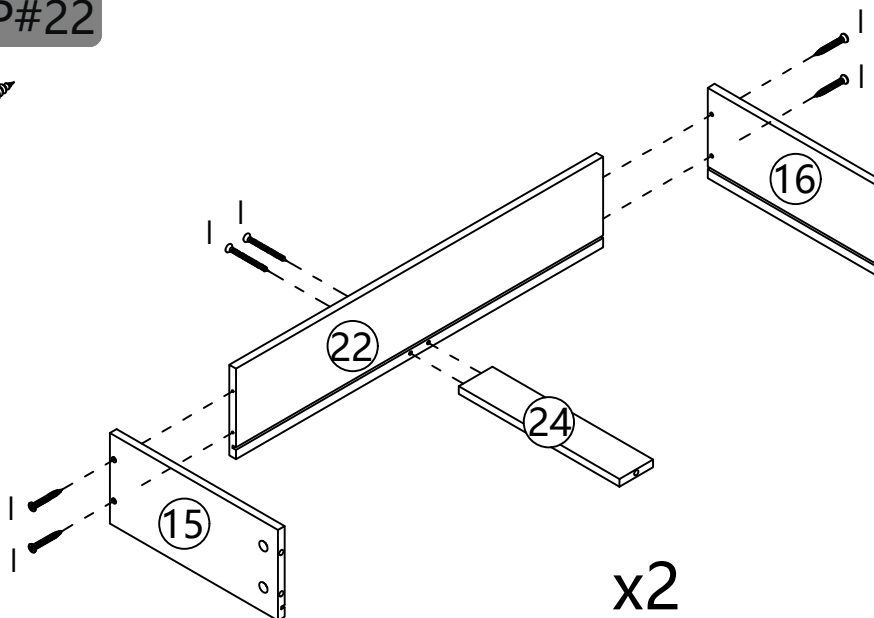

# STEP#23

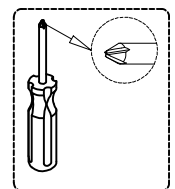
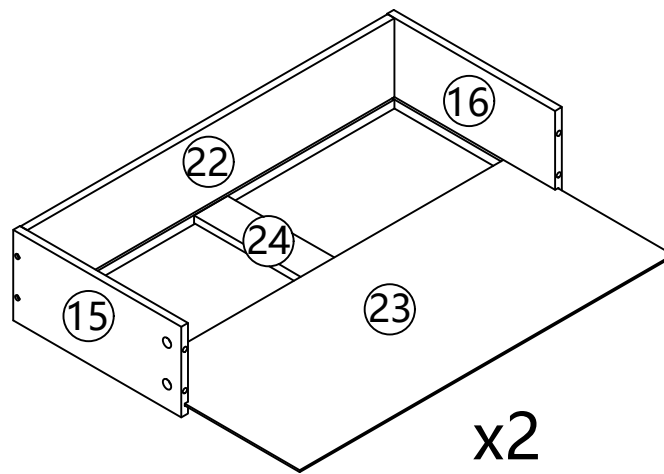

# STEP#24

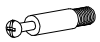

A x 10

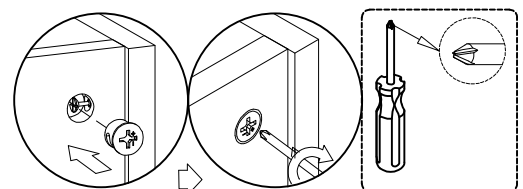
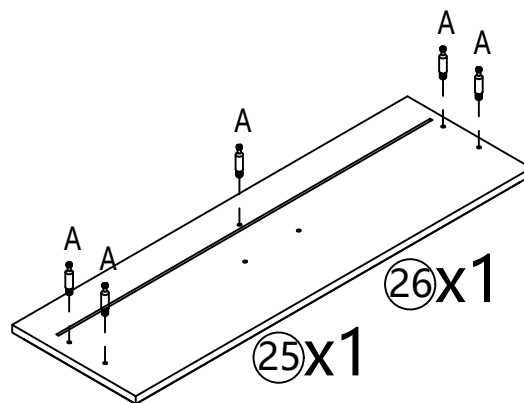

# STEP#25



B x 10

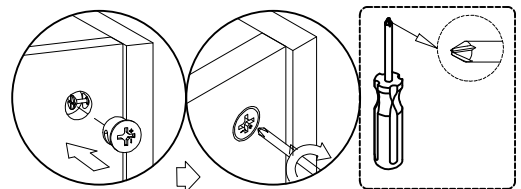
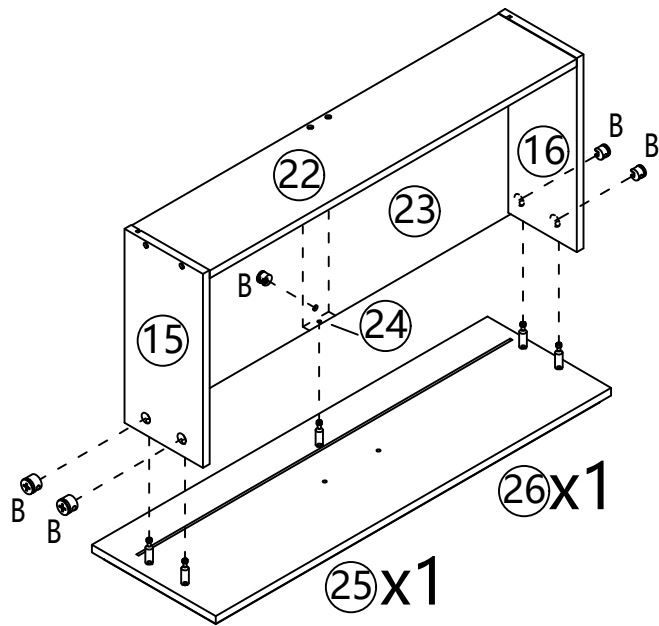

# STEP#26



G x 8



L x 2

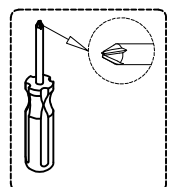
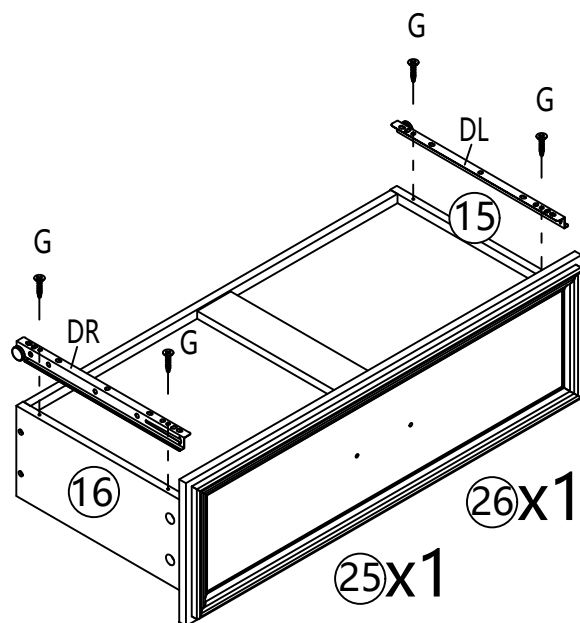

# STEP#27

  
E x 4

  
M x 2

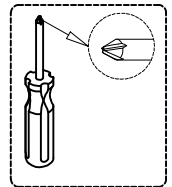
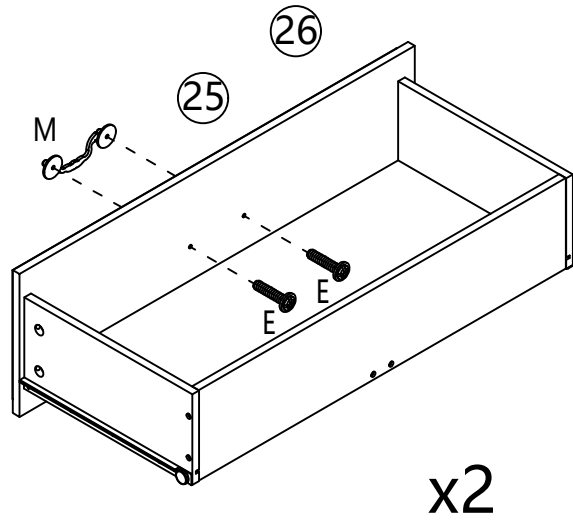

# STEP#28

  
I x 24

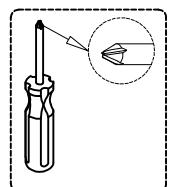
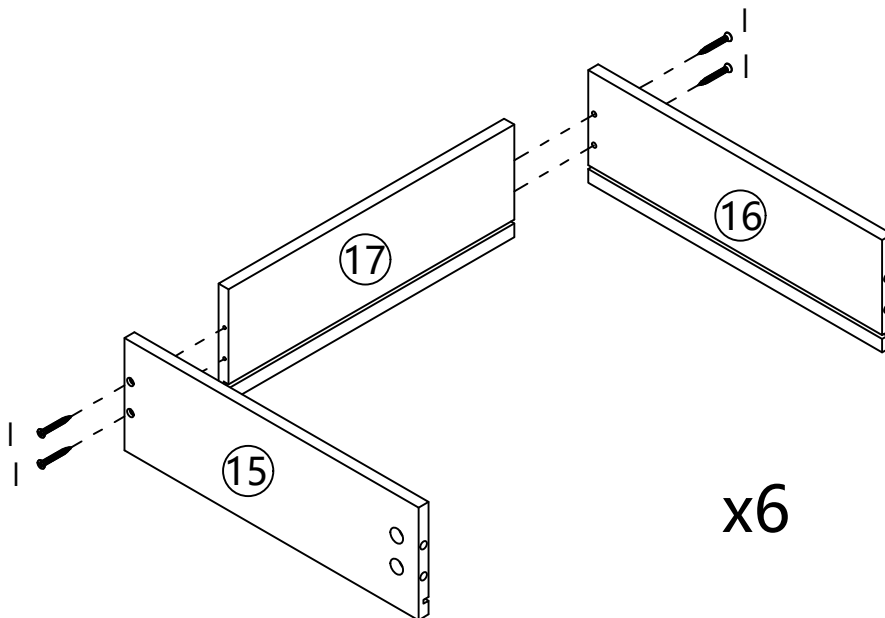

# STEP#29

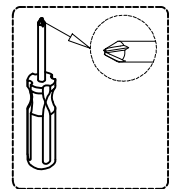
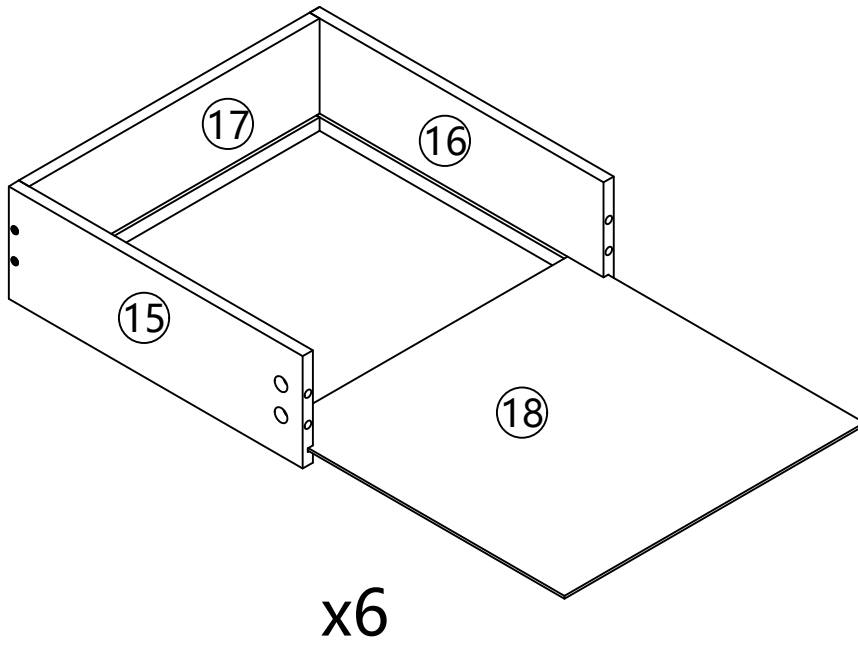

# STEP#30

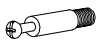

A x 24



B x 24

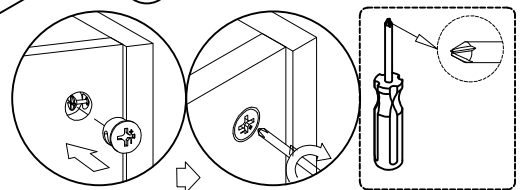
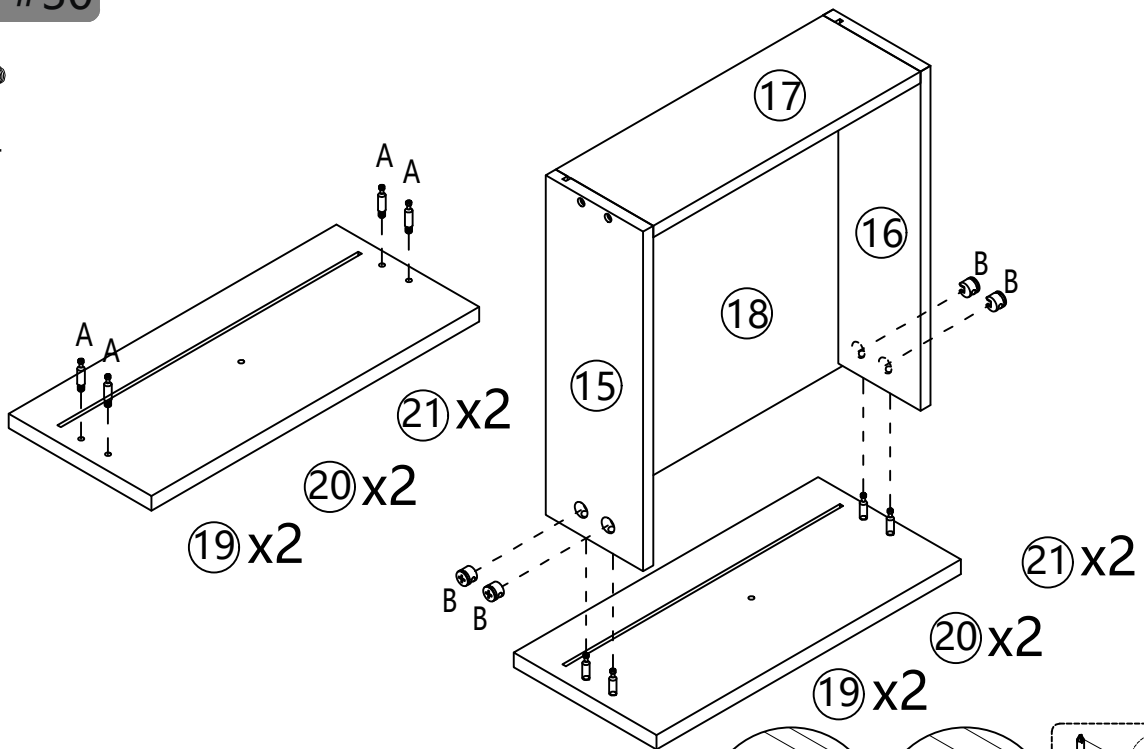

### STEP#31



G x 24

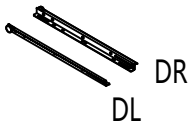

L x 6

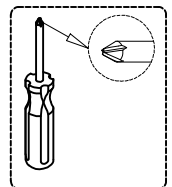
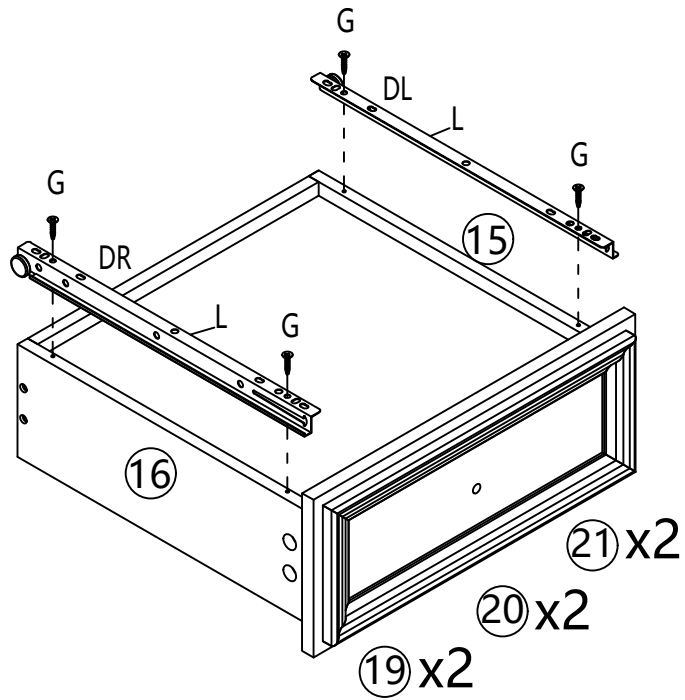

### STEP#32



E x 3



D x 3

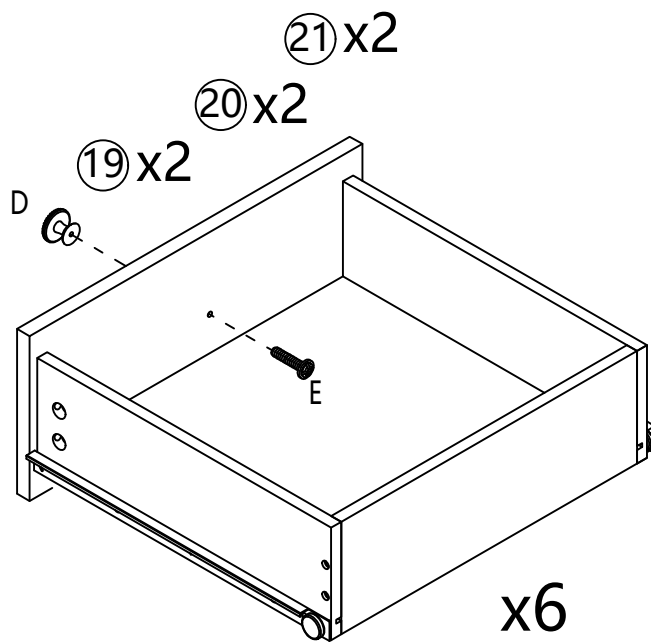

STEP#33

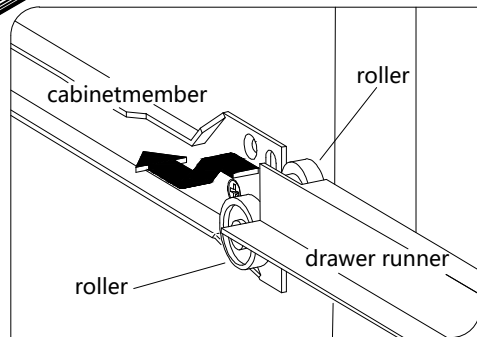
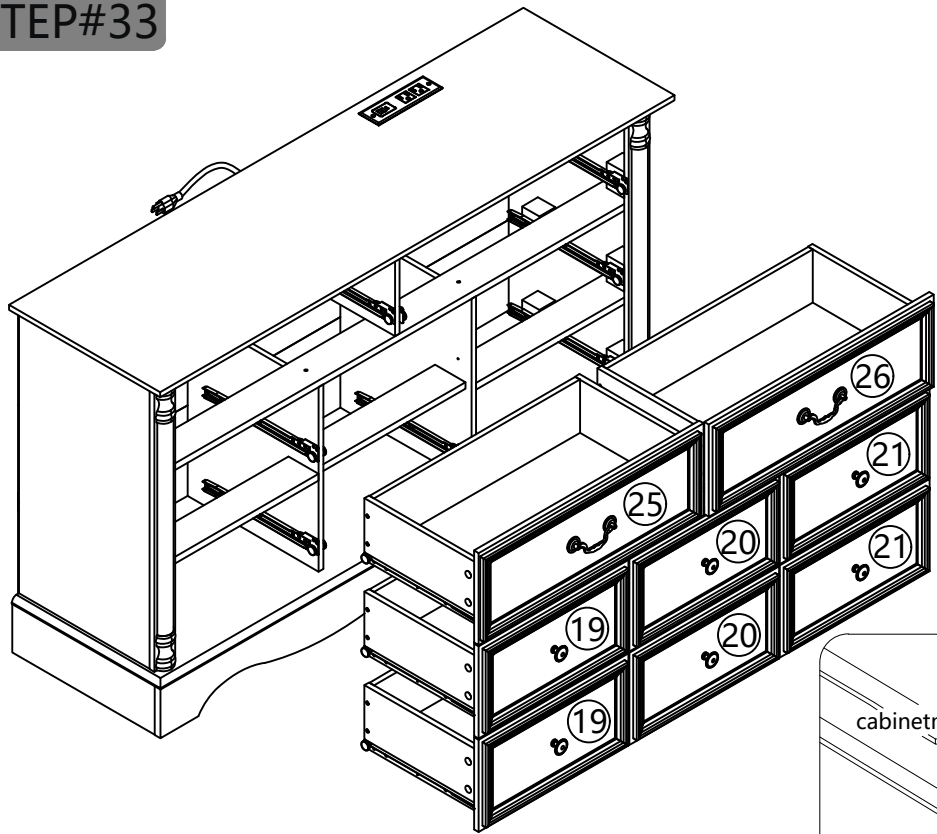

STEP#34

