

Assembly Instructions

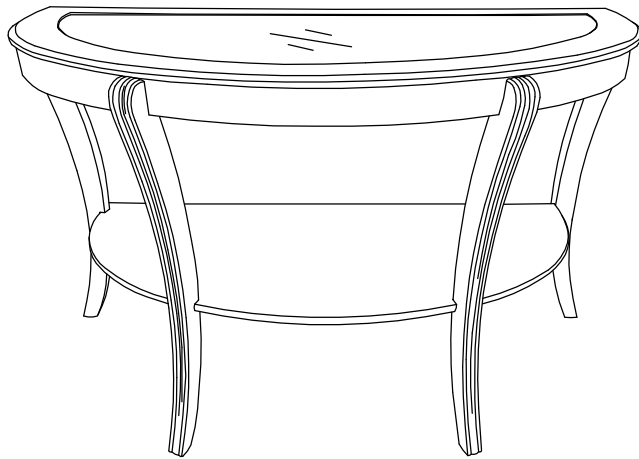

ASSEMBLY RATING

The Assembly Rating is a 5-point system that shows the degree of effort needed in assembling a specific product (with 1 being easy and 5 being difficult). For some products, two persons are recommended.

Tools Required For Assembly:

Allen Wrench

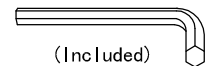

(Included)

EASY

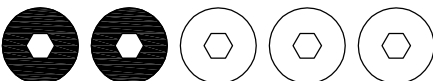

DIFFICULT

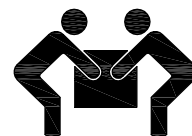

2 PERSONS RECOMMENDED

ASSEMBLY & CARE ADVICE

FOR YOUR FURNITURE TO LAST, CORRECT ASSEMBLY AND PROPER MAINTENANCE ARE NECESSARY. PLEASE FOLLOW THE INFORMATION PROVIDED BELOW TO FULLY ENJOY YOUR FURNITURE.

BASIC ASSEMBLY TECHNIQUES



When lock or spring washer is used in an assembly, please make sure the lock or spring washer is placed between the larger flat washer and the head of the screw or bolt.



Position each part correctly and insert screws or bolts into their respective holes by hand tighten or using the proper hand tool. Only tighten when step is completed or when instructed to do so.



Use cardboard or carpet area when assembling furniture to prevent scratches. Make sure the furniture rests on a flat and level surface with each leg evenly touching the floor.



Some furniture comes with height adjustment knobs underneath each leg. To lower or to raise each leg, you need to turn clockwise or counterclockwise, respectively.



Make sure all parts are properly aligned, then use the appropriate hand tool to completely tighten the bolts or screws. Do not use power tools and do not overtighten.



Save the instructions and store the Allen wrench or any supplied tool for later maintenance. After two weeks, check and tighten any loose hardware and repeat again every six months thereafter.

IT IS THE USER'S RESPONSIBILITY TO MAINTAIN THE FURNITURE. THE HARDWARE MAY LOOSEN OVER TIME AND MAY CAUSE THE FURNITURE TO BE WOBBLY AND UNABLE TO SUPPORT ITS INTENDED WEIGHT CAPACITY. THIS MAY LEAD TO COLLAPSE AND MAY CAUSE SERIOUS INJURY.

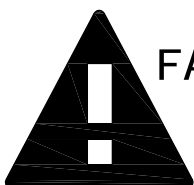

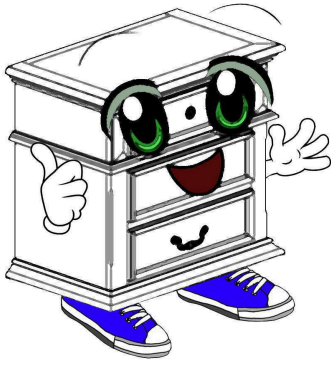

FAILURE TO FOLLOW THE GUIDELINES ABOVE MAY RESULT IN INJURY AND/OR PROPERTY DAMAGE.



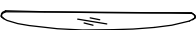
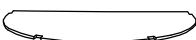

Before you begin, please read Page 2 of "Assembly and Care Advice".

And remember, do not tighten until each step is completed or instructed.





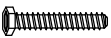

Parts List

-  #1 x 1pc
Table Top Frame
-  #2 x 1pc
Glass Top
-  #3 x 1pc
Shelf
-  #4 x 4pcs
Table Leg

Hardware List

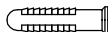
-  #A x 8pcs
Bolt $\phi 1/4" \times 2"$
-  #B x 8pcs
Bolt $\phi 1/4" \times 1/2"$
-  #C x 16pcs
Lock Washer
-  #D x 16pcs
Flat washer

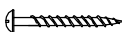
Hardware List

-  #E x 1pc
Allen Wrench
-  #F x 4pcs
Bracket
-  #G x 8pcs
Plastic Cap
-  #H x 1pc
Wall Anchor
-  #I x 1pc
Tightwire
-  #J x 1pc
Long Wood Screw
-  #K x 1pc
Medium Wood Screw



1) Prepare 6 bolts assembly. Insert lock washer (#C) to bolts (#A), then flat washer (#D) to the same bolts (#A).

- #A x 6pcs
- #C x 6pcs
- #D x 6pcs
- #G x 6pcs

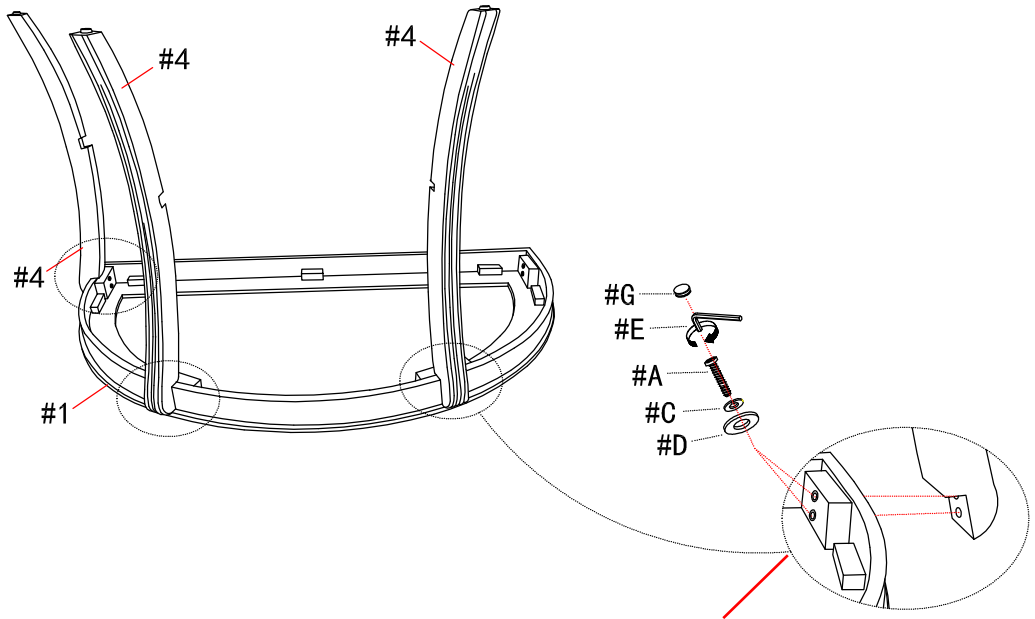

2) Align 3 table legs (#4) to the table top frame (#1), then secure with bolts (#A).



1) Prepare 8 bolts assembly. Insert lock washer (#C) to bolts (#B), then flat washer (#D) to bolts (#B). Prepare 2 bolts assembly by inserting lock washer (#C), then flat washer (#D) to bolts (#A).

2) Align shelf (#3) to the legs, then align the bracket (#F) to the shelf (#3) and legs (#4). Secure with bolts (#B).

- #A x 2pcs
- #B x 8pcs
- #C x 10pcs
- #D x 10pcs
- #F x 4pcs
- #G x 2pcs

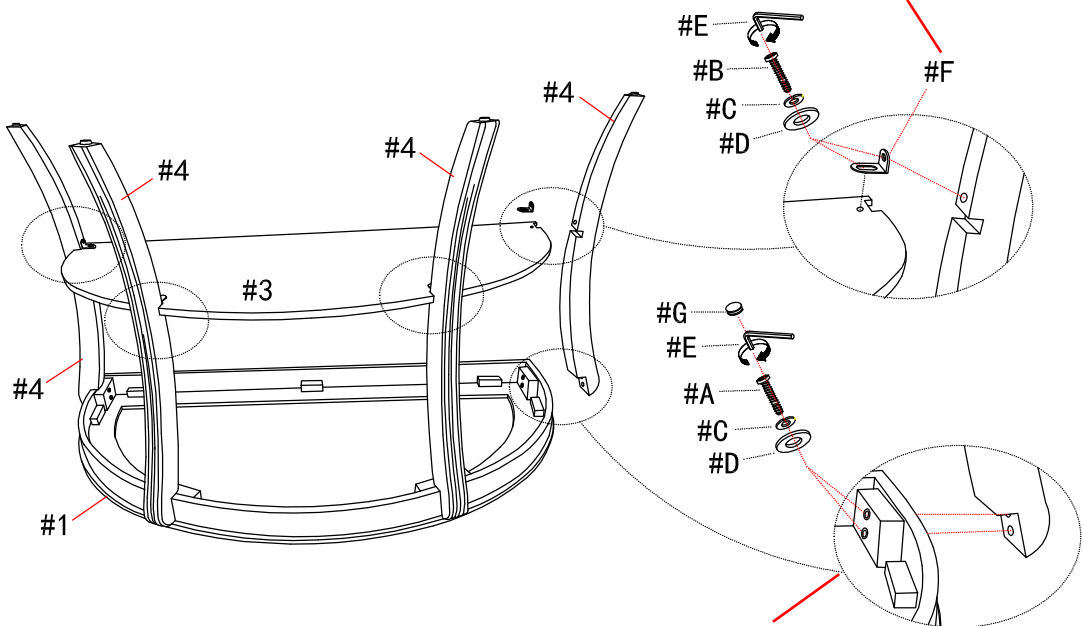

3) Align the last leg (#4) to the shelf (#3) and table top frame (#1). Secure leg (#4) to table top frame (#1) with bolts (#A) and then secure shelf (#3) to leg (#4) with bolts (#B).



Carefully place the glass top (#2) on the table.

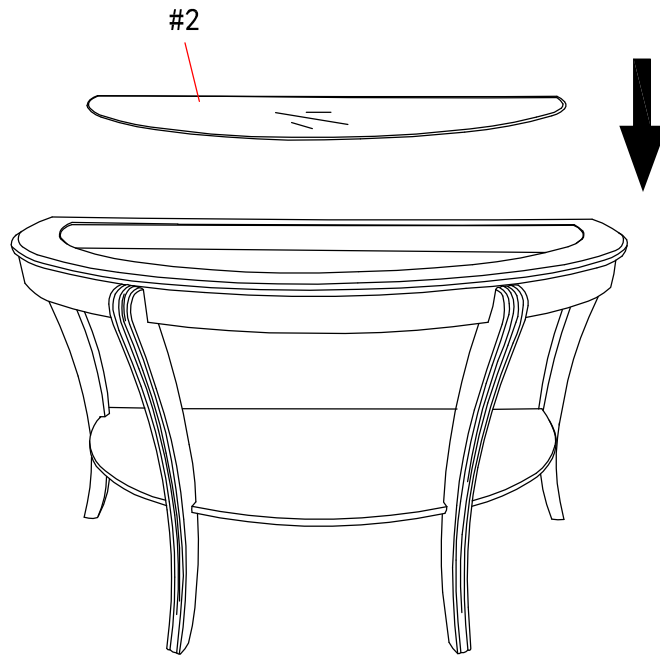

Attach fall prevention hardware to the wall, then to the table top frame (#1) to prevent the product from tipping.

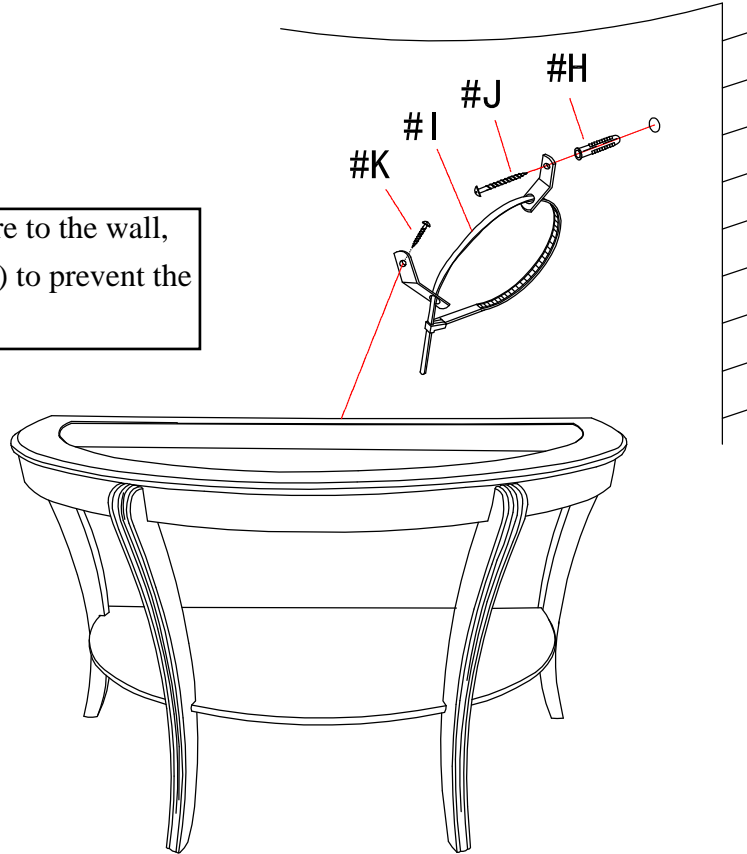

ASSEMBLY IS COMPLETELY