

# CHAIR & TABLE COMPANY

Thank you for purchasing a Chair & Table Company product. This product has been designed for easy assembly and is constructed for durability. Please take this time to read and follow the assembly instruction carefully. If a part or hardware is missing or you have any difficulties in assembling this product, please contact us.

## ASSEMBLY INSTRUCTION

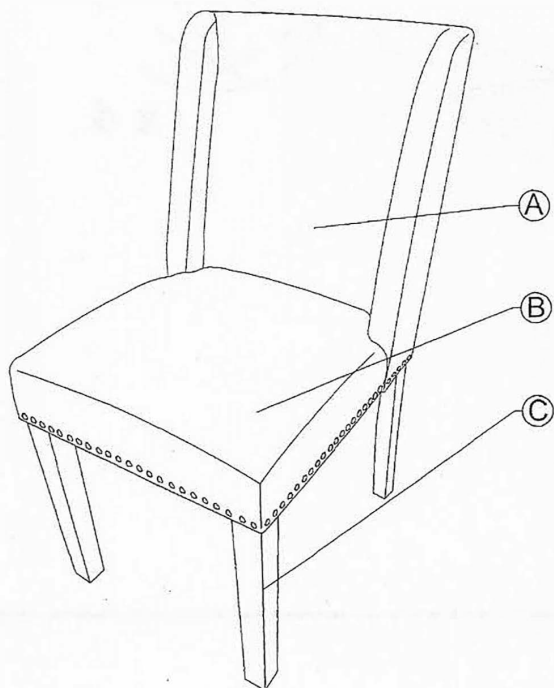

## PARTS CHECK LIST

CODE	COMPONENTS	Q'TY
Ⓐ	BACK REST	x01
Ⓑ	SEAT FRAME	x01
Ⓒ	FRONT LEG	x02

## FITTINGS CHECK LIST

CODE	DESCRIPTION	Q'TY
Ⓓ	 JCBC M6 x 40mm	x02
Ⓔ	 JCBC M6 x 60mm	x04
Ⓕ	 JCBC M6 x 90mm	x04
Ⓖ	 SPRING WASHER M6	x10
Ⓗ	 FLAT WASHER M6	x10
Ⓘ	 ALLEN KEY M4	x01

- Assemble front legs (C) to the seat frame (B) with JCBC (E), spring washer (G) and flat washer (H).  
Do not tighten all the screws until fully set up.

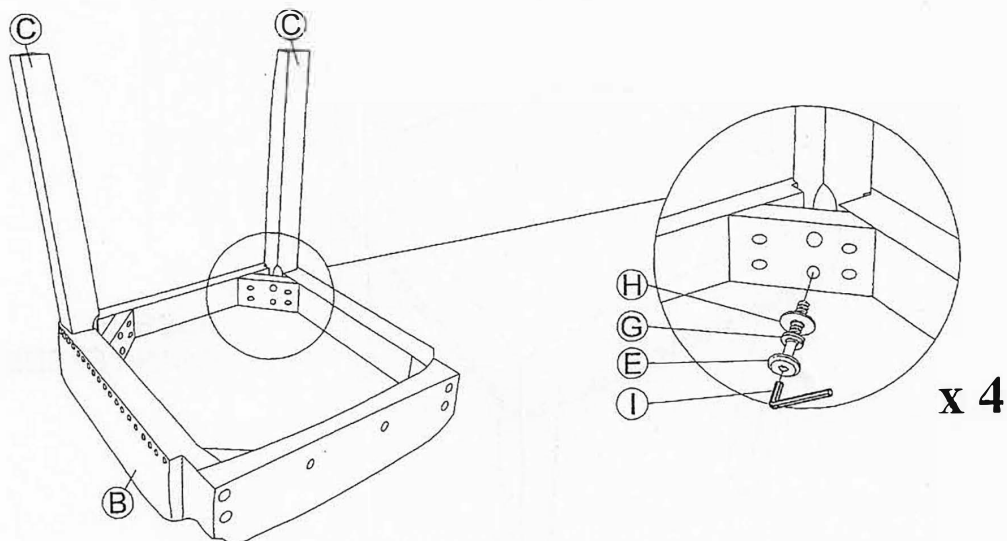

2. Assemble seat frame (B) and front leg (C) to the back rest (A) with JCBC (D), JCBC (F), spring washer (G) and flat washer (H).

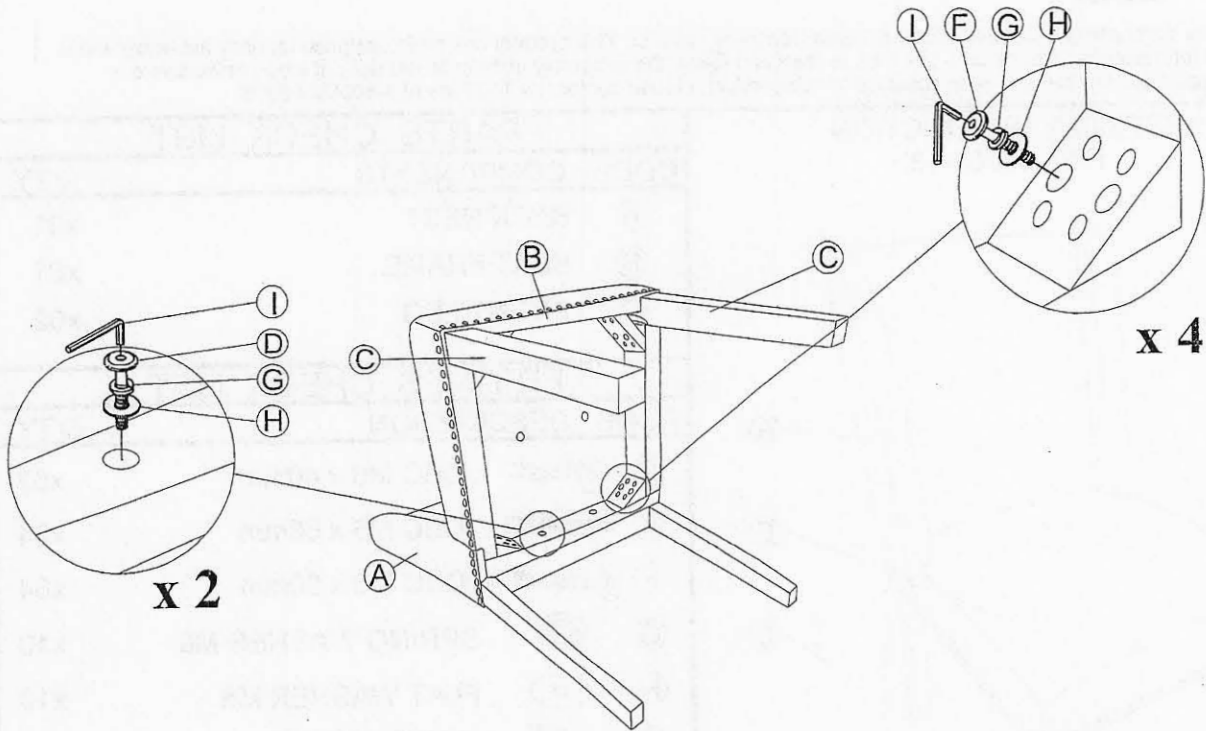

3. Please make sure all screws are tightened 100%.

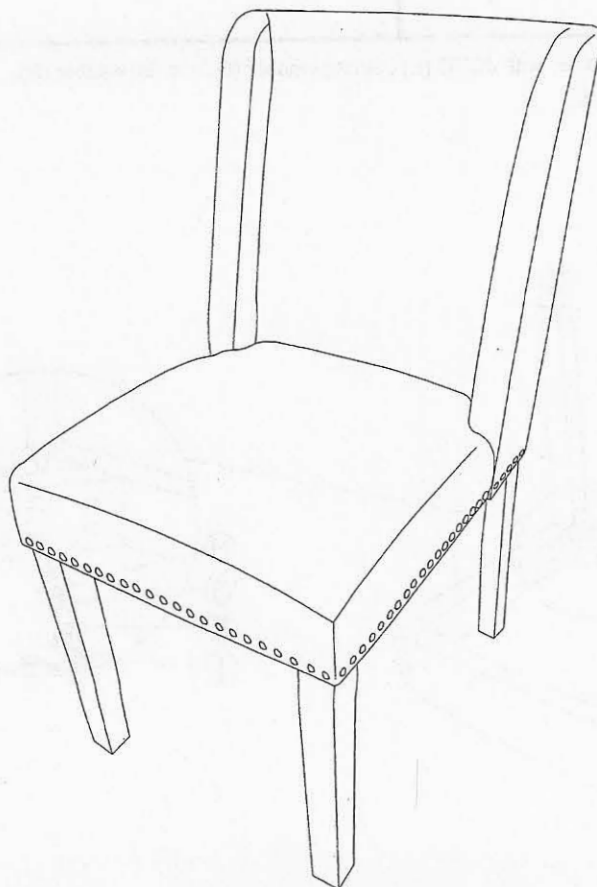

ASSEMBLY  
COMPLETED!!!