

# ASSEMBLY INSTRUCTION

NO	PARTLIST	QTY
1	HEADBOARD CUSHION	1PC
2	HEADBOARD LEG (LEFT)	1PC
3	HEADBOARD LEG (RIGHT)	1PC
4	FOOTBOARD CUSHION	1PC
5	FOOTBOARD LEG	2PCS
6	SIDE RAIL	2PCS
7	SIDE RAIL	2PCS
8	SIDE RAIL SUPPORT LEG	2PCS
9	ROLL SLAT 6PCS / SET	2SET
10	SUPPORT LEGS WITH ADJUSTABLE FEET	8PCS
11	CENTER SUPPORT RAIL	4PCS
ITEM	HARDWARE	QTY
A	JCBB SCREW M8 x 20MM	8PCS
B	JCBB SCREW M6 x 25MM	8PCS
C	JCBC SCREW M6 x 50MM	14PCS
D	JCBC SCREW M6 x 100MM	2PCS
E	WOOD DOWEL M8 x 30MM	2PCS
F	SPRING WASHER M6 x 13MM	14PCS
G	FLAT WASHER M6 x 19MM	14PCS
H	SCREW M4 x 32MM	8PCS
I	L-KEY M5 x 65MM	1PC
J	L-KEY M4 x 100MM	1PC

STEP 1 Open zipper to get all other parts.

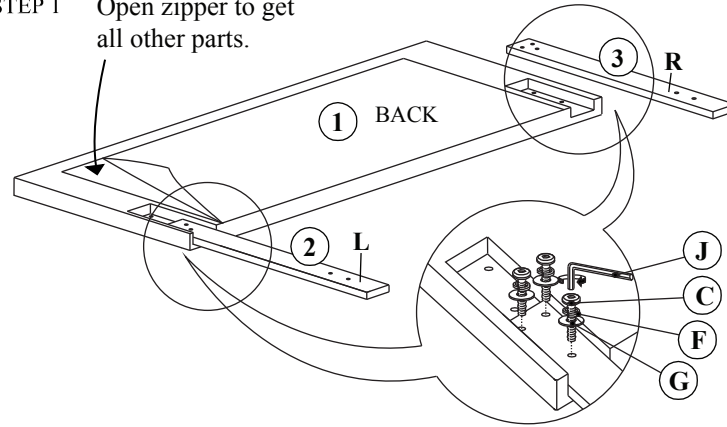

STEP 2

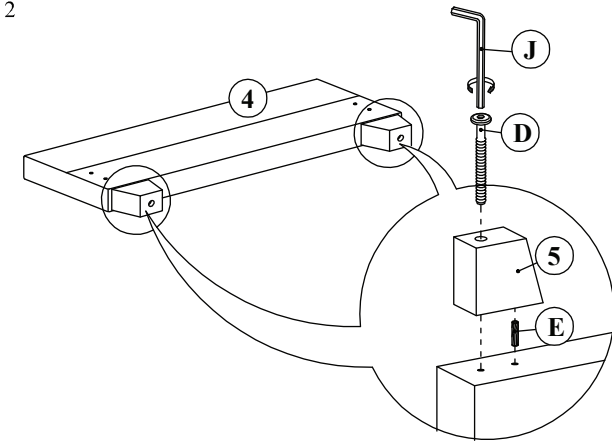

STEP 3

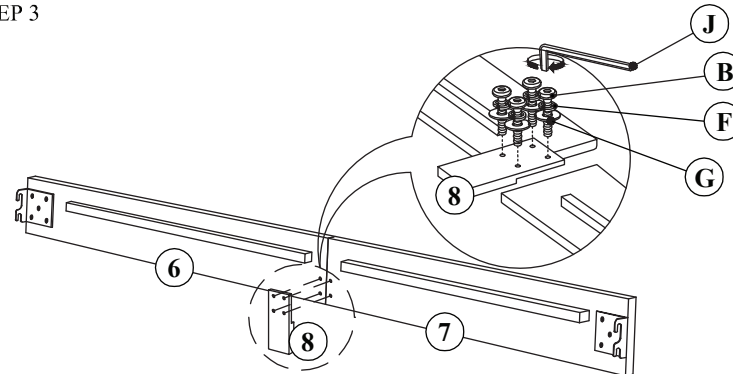

STEP 4

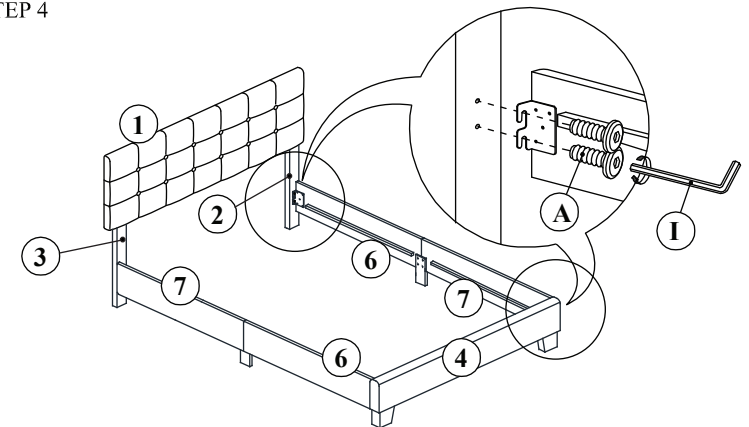

STEP 5

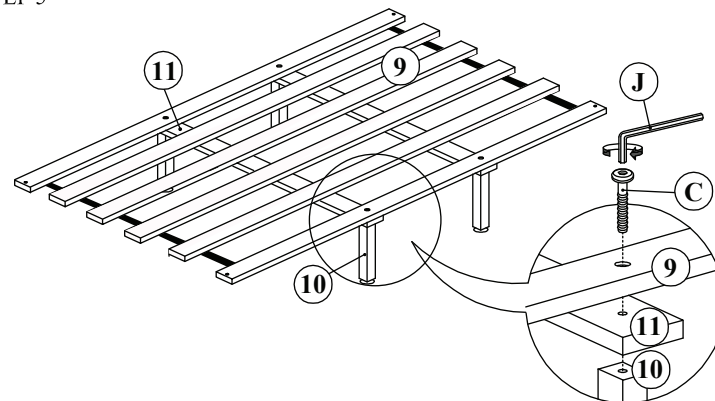

STEP 6

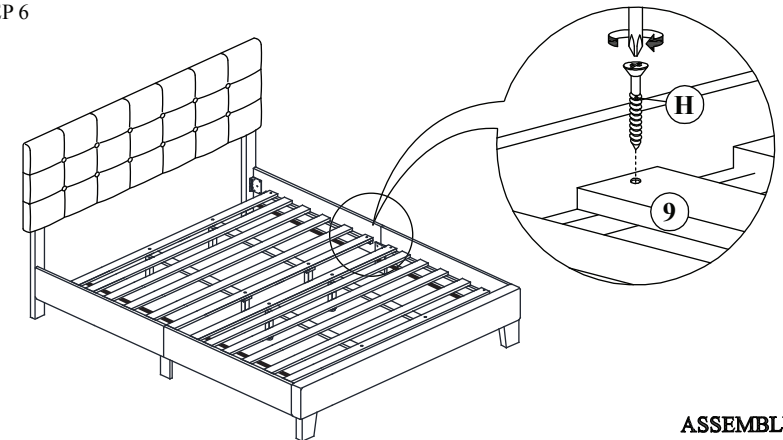

ASSEMBLY COMPLETED