

Thank you for your purchase!

PLATFORM BED FRAME

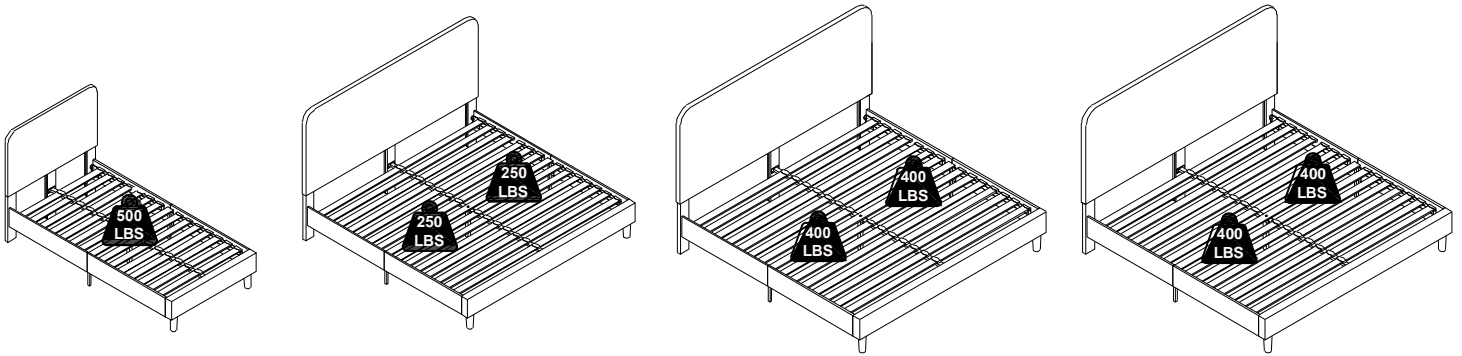

TWIN SIZE

FULL SIZE

QUEEN SIZE

KING SIZE

ASSEMBLY INSTRUCTIONS

Before You Begin:

Please identify all component parts and hardware pieces required before you begin. Carefully remove all of the components from the packaging and set aside for assembly. Assemble on a soft surface to prevent scratching during assembly.

Caution:

Tighten all components securely before use. Failure to do so may result in personal injury. DO NOT use any sharp objects to open plastic wrapped components as damage to product or components may result.

Warning:

CHOKING HAZARD - Small Parts. Adult Assembly Required.









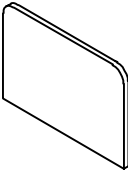

DO NOT ALLOW CHILDREN TO CLIMB ON FURNITURE

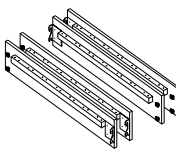
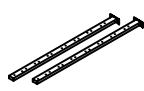
Serious or fatal injuries can occur from furniture tipping over. You must install Tipping Restraint Hardware (where included) to help prevent the unit from tipping and causing accidental injury, instability, death or damage. The tipping restraint is intended only as a safety measure, it is not a substitute for proper adult supervision.

To help prevent furniture from tipping over it must be permanently attached to the wall. Anti-Tip Safety Wall Straps suitable for the unit weight and wall materials (if not included) should be purchased and installed.

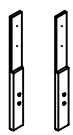
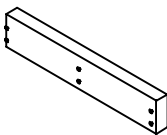
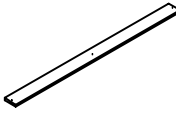
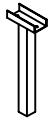
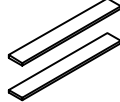
PLATFORM BED FRAME INSTRUCTION

Components

(A) Headboard  1pc	(C) Headboard Middle Leg  1pc	(E) Side Rails  4pcs	(G) Middle Cross Beam  2pcs	(I) Middle Brace Feet  2pcs	(K) Bed Legs  2pcs	(M) Screw $\phi 8 \times 40$  11pcs	(O) Outer Slat Holders  28pcs
(B) Headboard Side Legs  2pcs	(D) Footboard  1pc	(F) Middle Brace  1pc	(H) Middle Leg  1pc	(J) Slats  28pcs	(L) Washers $\phi 8$  11pcs	(N) Allen Wrench  1pc	(P) Middle Slat Holders  14pcs

1

STEP 1: Attach Headboard Side Legs (Part B) and Headboard Middle Leg (Part C) to Headboard (Part A) using (6) Washers (Part L) and (6) 8*40 Screws (Part M). Tighten with Allen Wrench (Part N)

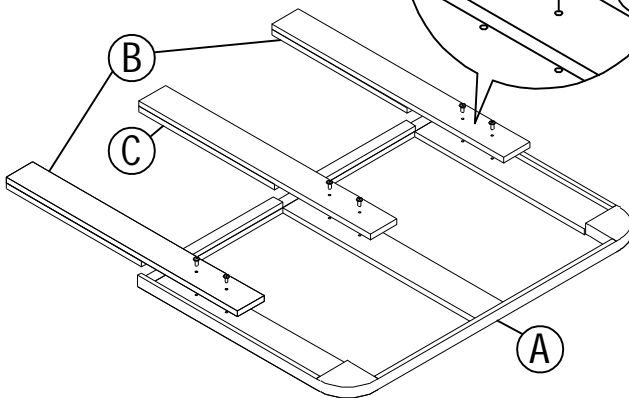

2

STEP 2: Insert Bed Legs (Part K) into Footboard (Part D) and turn clockwise to tighten.

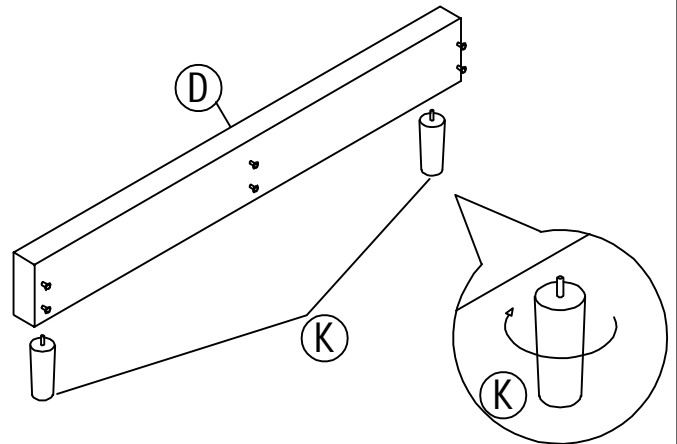

Note: Screws preassembled on the footboard

3

STEP 3: Attach Middle Cross Beam (Part G) to Middle Leg (Part H) using (2) Washers (Part L) and (2) 8*40 Screws (Part M). Tighten with Allen Wrench (Part N)

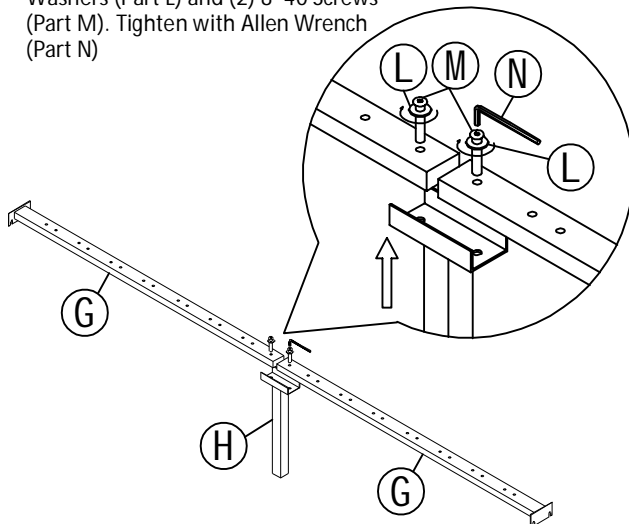

4

STEP 4: Attach Middle Brace (Part F) to Middle Brace Feet (Part I) using (2) Washers (Part L) and (2) 8*40 Screws (Part M). Tighten with Allen Wrench (Part N)

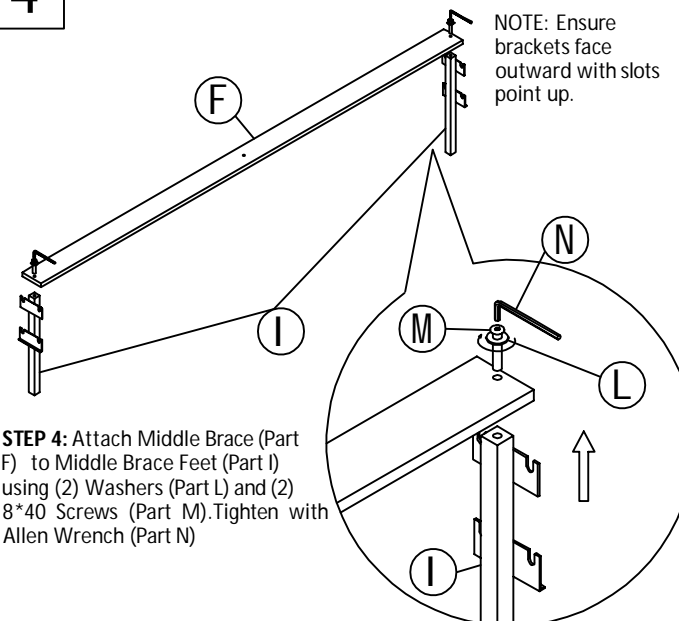

NOTE: Ensure brackets face outward with slots point up.

5

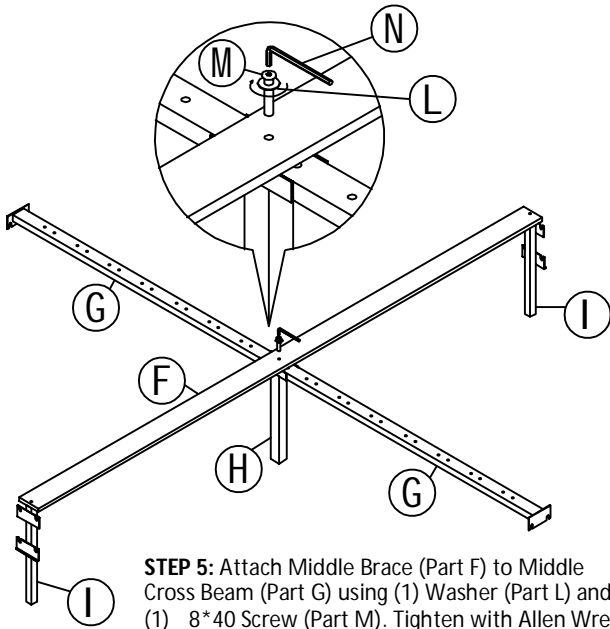

STEP 5: Attach Middle Brace (Part F) to Middle Cross Beam (Part G) using (1) Washer (Part L) and (1) 8*40 Screw (Part M). Tighten with Allen Wrench (Part N)

6

STEP 6A: Remove preassembled screws from middle leg. Attach Middle Cross Beam (Part G) to Middle Headboard Leg using preassembled screws.

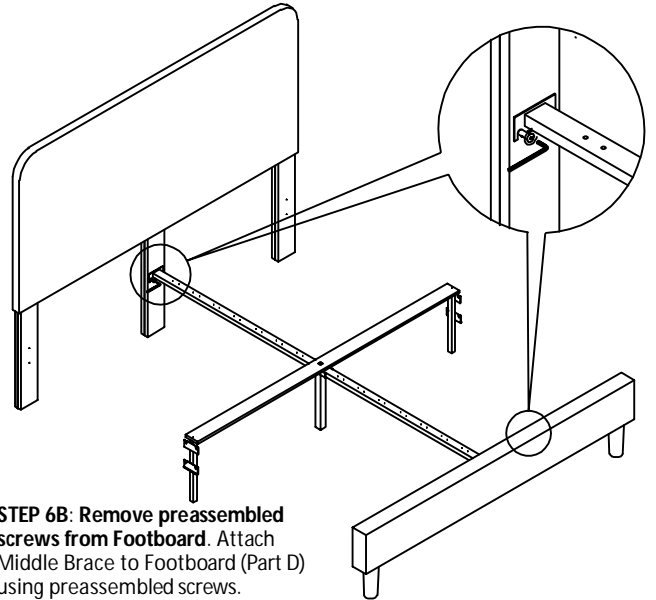

STEP 6B: Remove preassembled screws from Footboard. Attach Middle Brace to Footboard (Part D) using preassembled screws.

7

STEP 7: Remove remaining preassembled screws from Headboard Side Legs and Footboard. Attach Siderails (Part E) to Headboard and Footboard using preassembled screws.

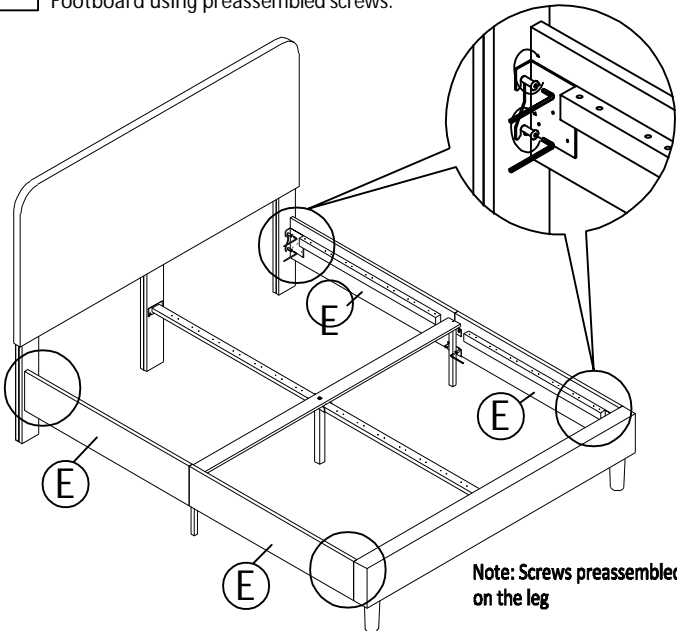

Note: Screws preassembled on the leg

8

STEP 8: Loosen preassembled screws from Siderails (Part E). Insert screws into the slots of the Middle Legs then tighten screws.

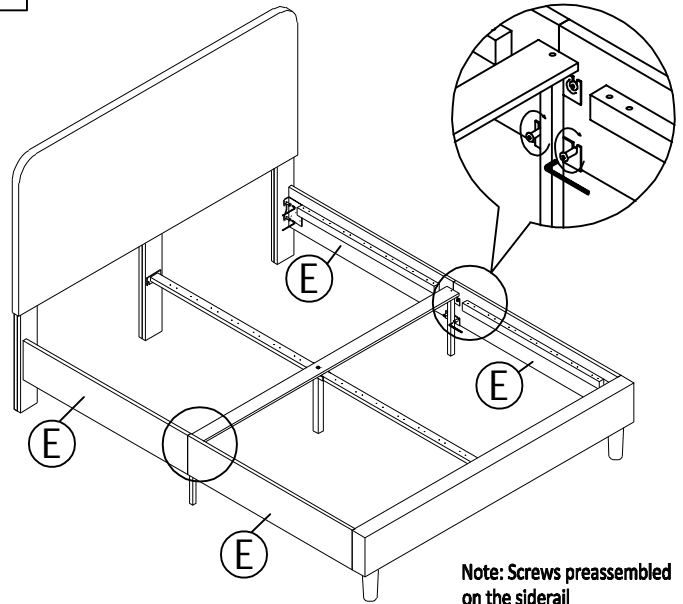

Note: Screws preassembled on the siderail

9

STEP 9: Insert (28) Slats (Part J) into the left and right sides of the Middle Slat Holders (Part P). Insert Slats into Outer Slat Holders (Part O). Push down on slat holders to secure.

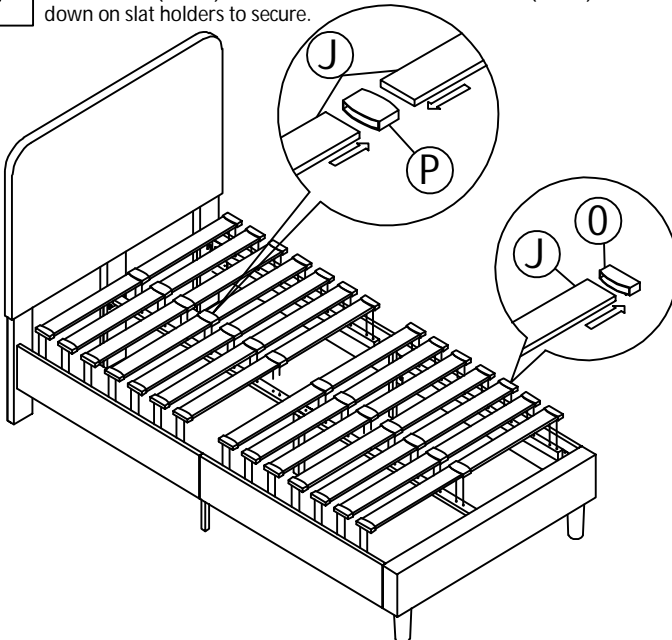

10

STEP 10: Ensure all screws and slats are secure.

