

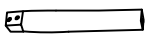



ASSEMBLY INSTRUCTION

NO.	PARTS LIST		Q'TY
A		TABLE TOP	1PC
B		TABLE LEG	4PCS

NO.	HARDWARE LIST		Q'TY
C		WRENCH 5MM	1PC
D		BOLT Ø5/16*2-1/2"	8PCS
E		LOCK WASHER Ø5/16"	8PCS
F		FLAT WASHER Ø5/16"*22MM	8PCS



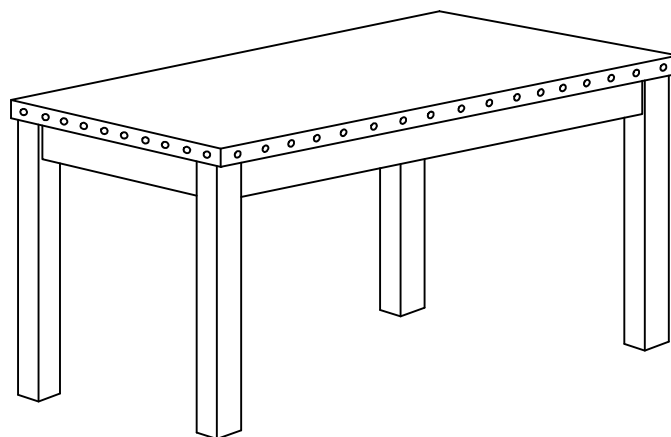
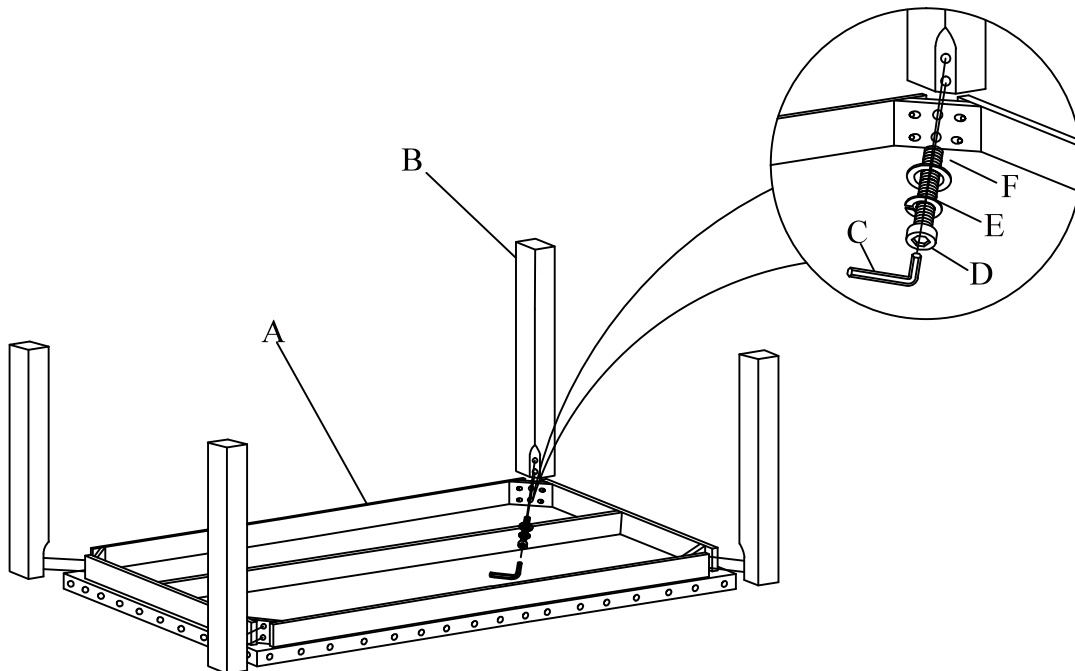

Caution: Please do not tighten all bolts until the table is completely assembled!







MADE IN VIETNAM

ASSEMBLY INSTRUCTION

PARTS LIST

NO.	DESCRIPTION	SKETCH	QTY
A	FRONT LEGS		2PCS
B	SEAT FRAME		1PC
C	CHAIR BACK		1PC

HARDWARE LIST

N O .	DESCRIPTION	SKETCH	Q T Y
D	WRENCH 5MM		1PC
E	BOLT Ø5/16" * 3-1/2"		4PCS
F	BOLT Ø5/16" * 2"		6PCS
G	LOCK WASHER 5/16" * 22MM		10PCS
H	FLAT WASHER 5/16"		10PCS
I	WOOD DOWEL Ø10 * 30mm		1 PCS

STEP : 1

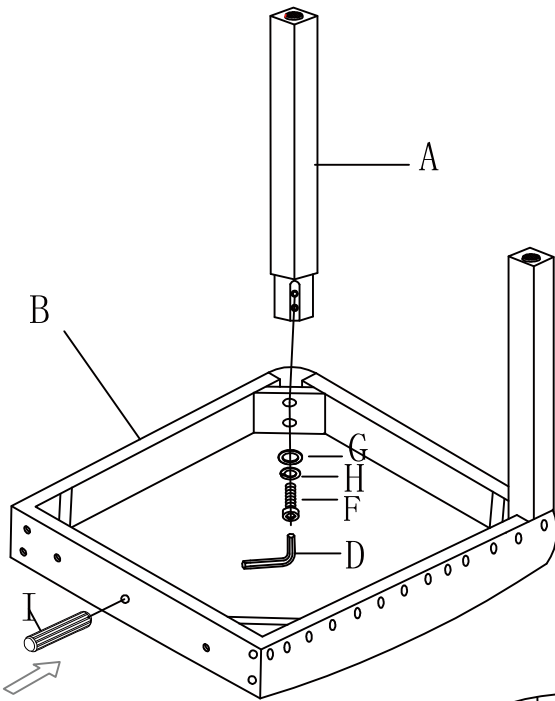

WOOD DOWEL

STEP : 2

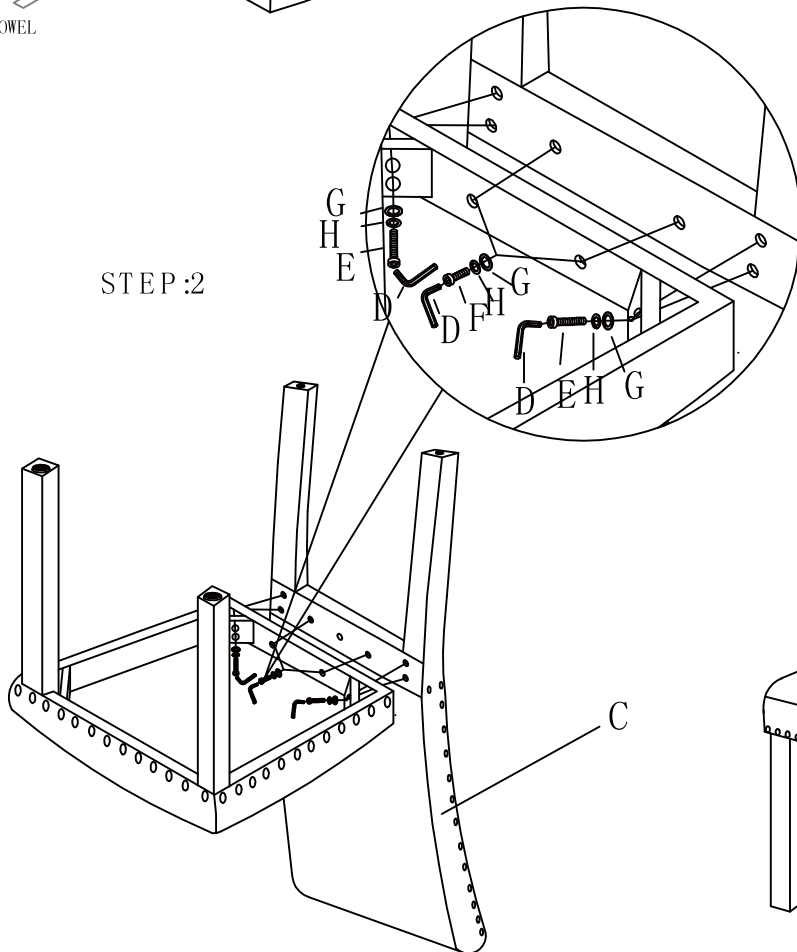

Please balance all 4 chair legs on the same level & tighten all the screws.

STEP : 3

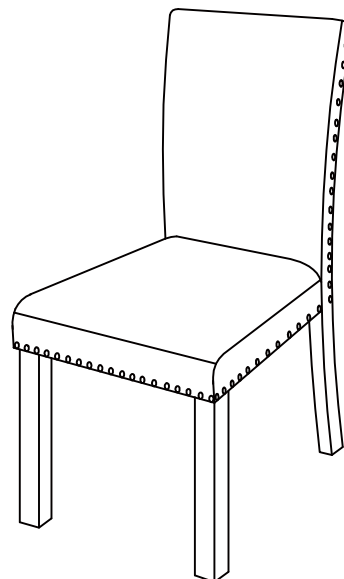



Caution: Please do not tighten all bolts until the chair is completely assembled!





MADE IN VIETNAM

ASSEMBLY INSTRUCTION

PARTS LIST

NO.	DESCRIPTION	SKETCH	QTY
A	TOP		1PC
B	LEGS		4PCS

HARDWARE LIST

NO.	DESCRIPTION	SKETCH	QTY
C	WRENCH 5MM		1PC
D	BOLT $\times 5/16"$ *2"		8PCS
E	LOCK WASHER 5/16"*22MM		8PCS
F	FLAT WASHER 5/16"		8PCS

STEP:1

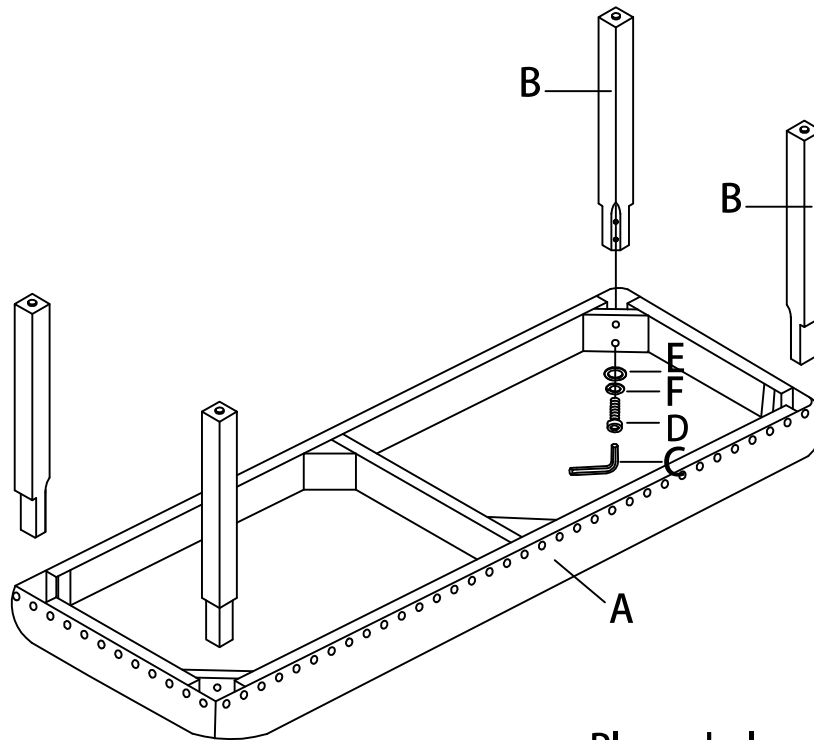

Please balance all 4 bench legs on the same level&tighten all the screws.

STEP:2

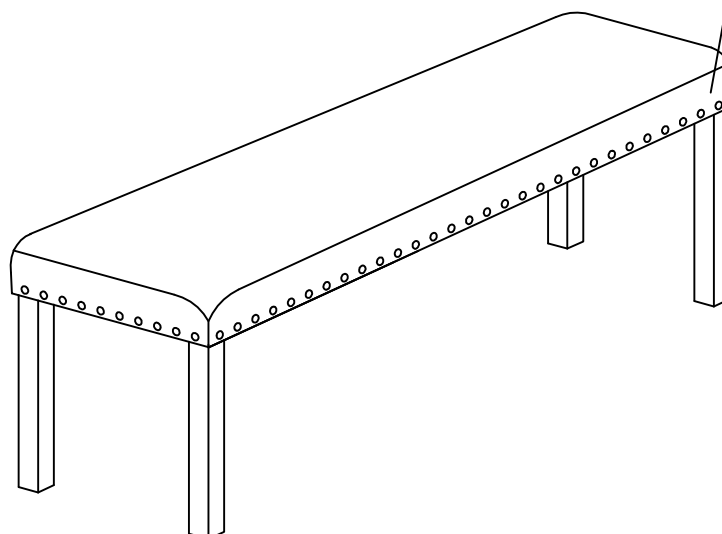

Caution:Please do not tighten all bolts until the bench is completely assembled!

MADE IN VIETNAM