

Assembly Instructions

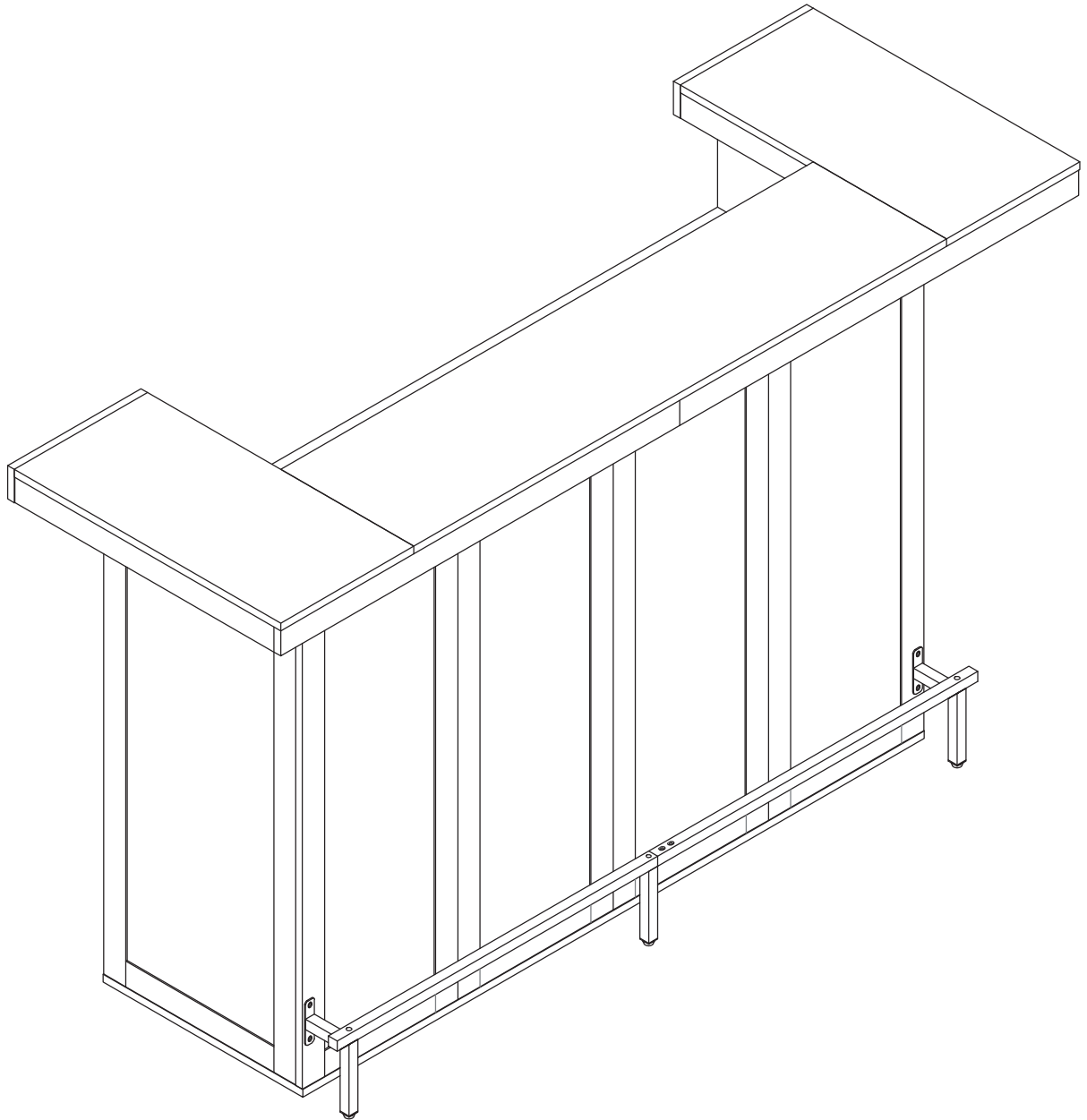

Bar Table

Contact Us

We're here to help you.

Your satisfaction is our top priority. If you encounter any issues with this product, such as missing or damaged parts, we're here to help. Please retain the original packaging and take photos of the packaging and the product, then contact us as soon as possible.

Warm Tips

1. Carefully read these instructions and keep them for future reference.
2. Check the parts list and confirm everything's there before starting assembly.
3. When assembling, put all parts on a soft, smooth surface like a carpet to avoid scratches.
4. Don't fully tighten screws until all parts are confirmed in place to avoid misalignment.

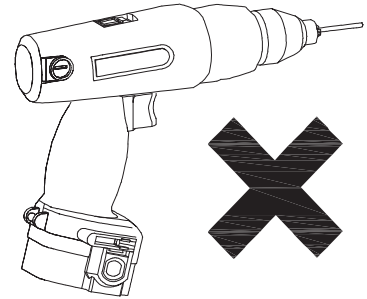
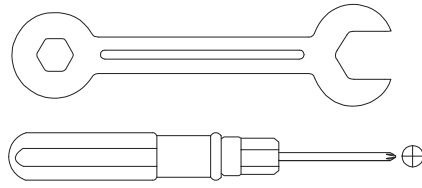
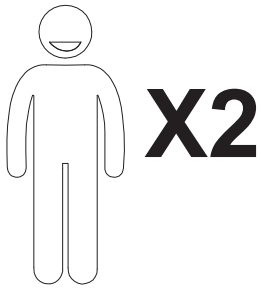

We recommend using hand tools for assembly.

If an electric screwdriver is used, reduce power and torque to avoid damage to the product.

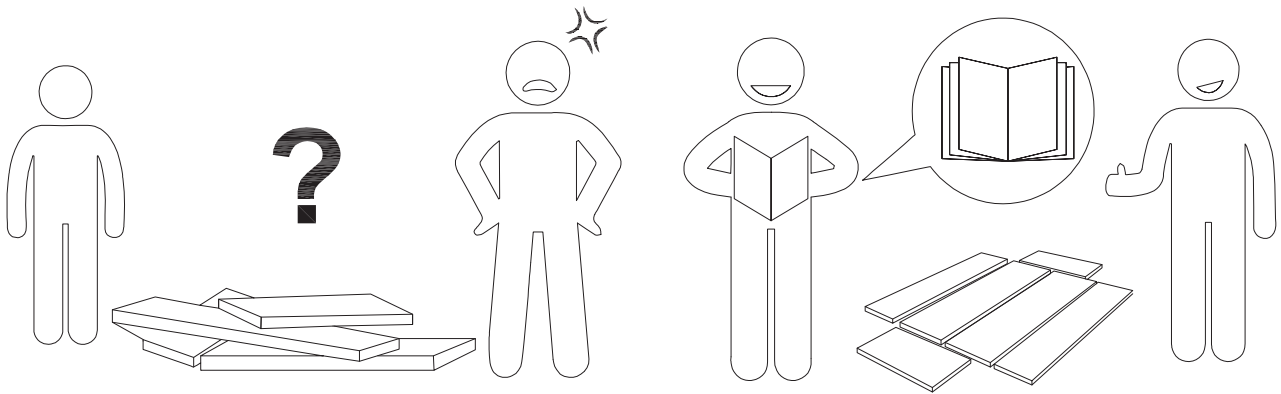

AVOID SCRATCHES

In order to avoid scratching, this furniture should be assembled on a soft surface, such as a rug.

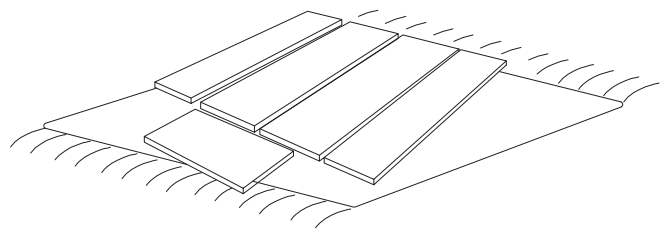
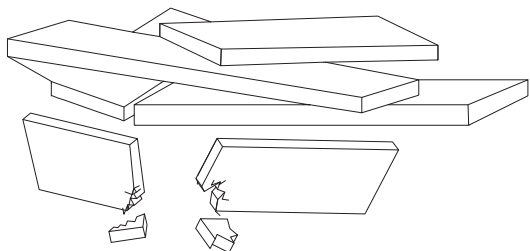

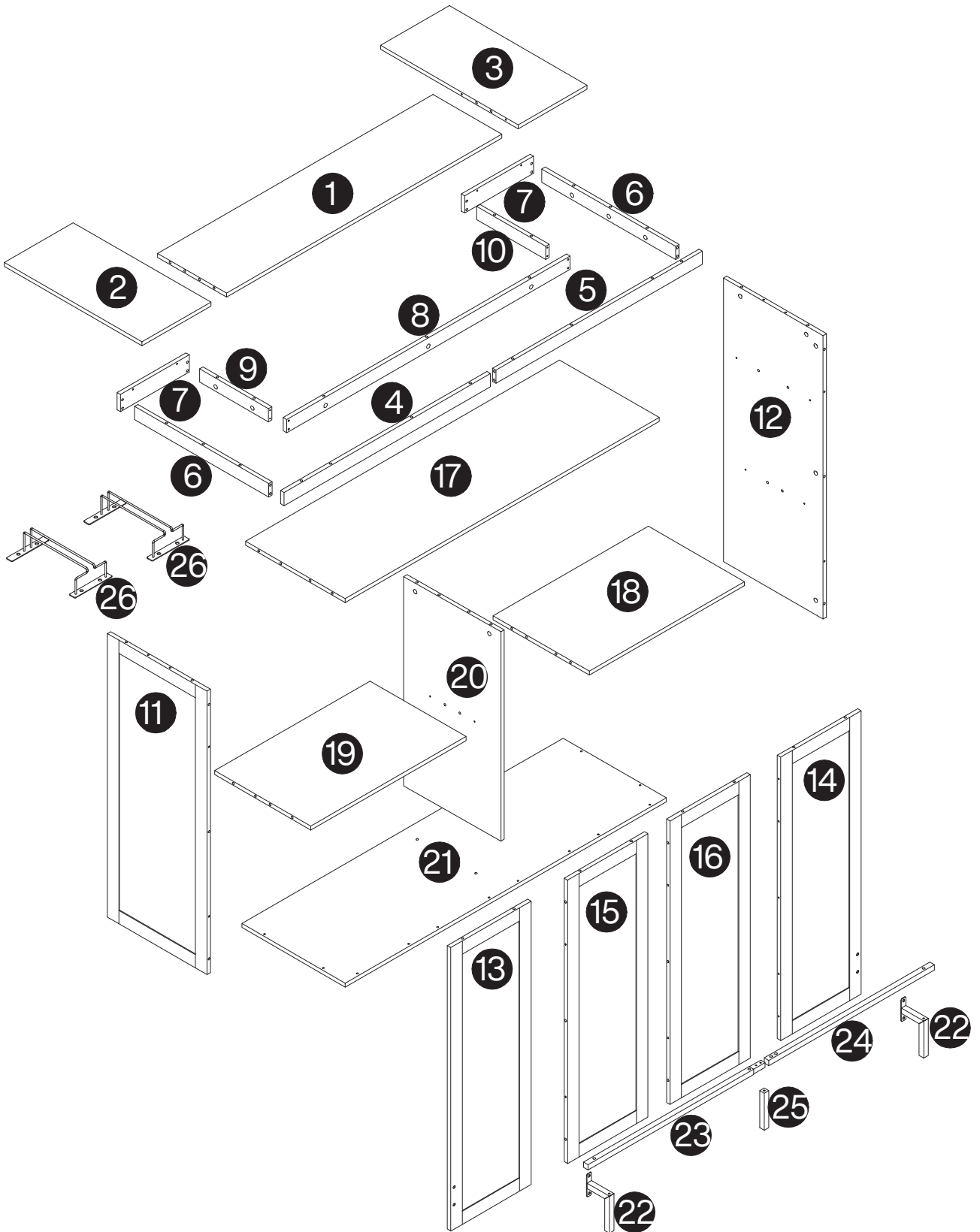



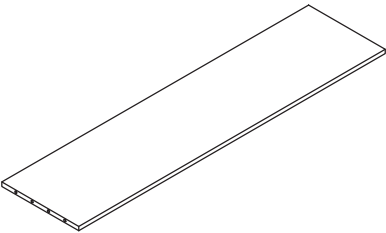
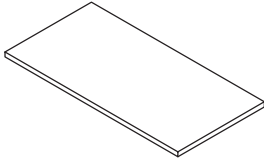
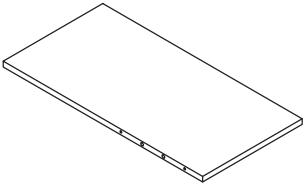
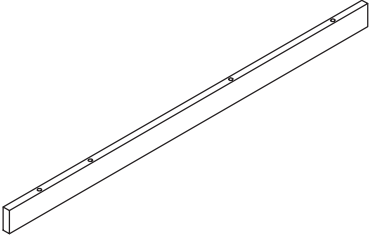
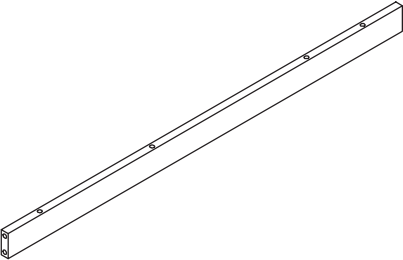
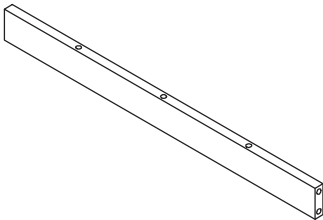
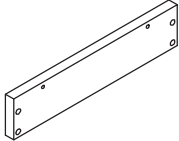
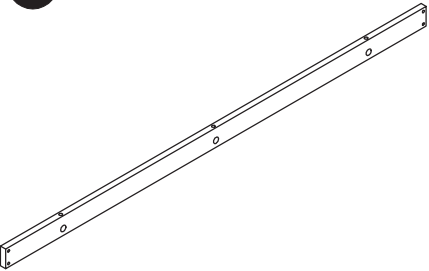
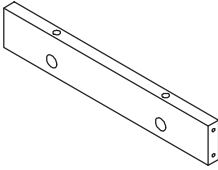
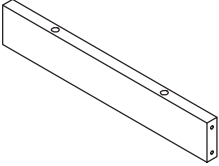
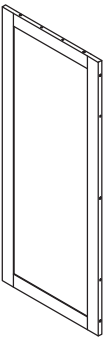

⚠ Caution

Make sure all parts are included. Most board parts are labeled or stamped on the raw edge. Contact us for a free replacement if you encounter any damaged or missing parts.

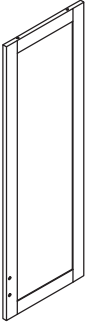

Parts List

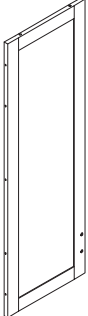
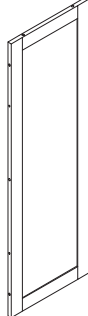
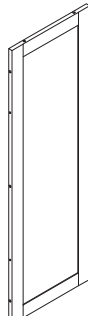
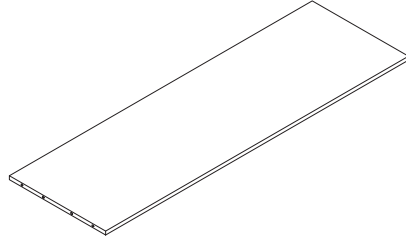
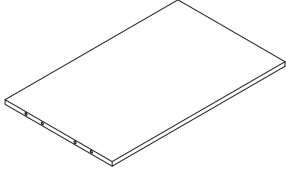
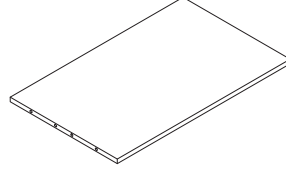
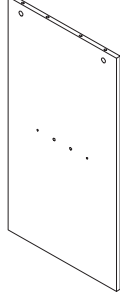
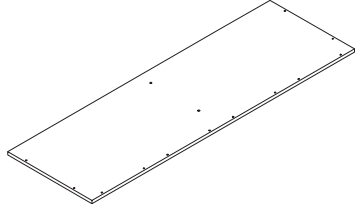
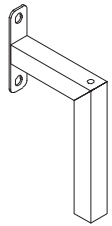
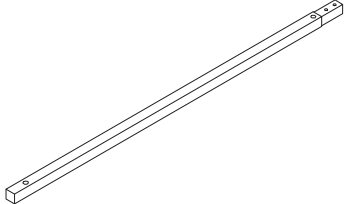
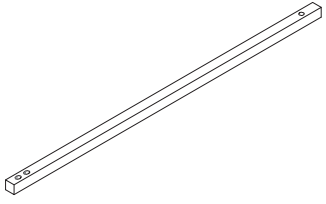

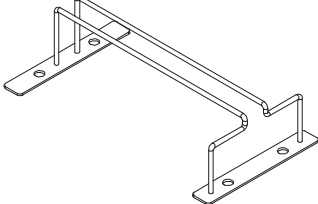
<p>1</p>  <p>1pc</p>	<p>2</p>  <p>1pc</p>	
<p>3</p>  <p>1pc</p>	<p>4</p>  <p>1pc</p>	
<p>5</p>  <p>1pc</p>	<p>6</p>  <p>2 pcs</p>	<p>7</p>  <p>2 pcs</p>
<p>8</p>  <p>1pc</p>	<p>9</p>  <p>1pc</p>	<p>10</p>  <p>1pc</p>
<p>11</p>  <p>1pc</p>	<p>12</p>  <p>1pc</p>	<p>13</p>  <p>1pc</p>

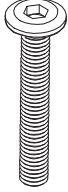

Parts List

<p>14</p>  <p>1pc</p>	<p>15</p>  <p>1pc</p>	
<p>16</p>  <p>1pc</p>	<p>17</p>  <p>1pc</p>	
<p>18</p>  <p>1pc</p>	<p>19</p>  <p>1pc</p>	<p>20</p>  <p>1pc</p>
<p>21</p>  <p>1pc</p>	<p>22</p>  <p>2 pcs</p>	<p>23</p>  <p>1pc</p>
<p>24</p>  <p>1pc</p>	<p>25</p>  <p>1pc</p>	<p>26</p>  <p>2 pcs</p>

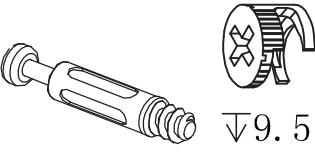
Hardware List

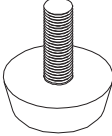
A	B	C
 <p>M6X10mm</p>	 <p>M6X40mm</p>	 <p>ST5X40mm</p>
14+1 pcs	3 pcs	18+1 pcs

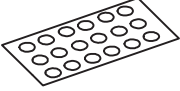
D	E	F
 <p>ST6X40mm</p>	 <p>Ø8 x 35mm</p>	 <p>M8</p>
70+5 pcs	46+2 pcs	3 pcs

 <p>→70</p>	 <p>4#</p>	 <p>3#</p>
1 pc	1 pc	1 pc

		
1 pc		

Installation of Cams and Pins

Read each step carefully before starting. Each step of instruction should be performed in the correct order. If these steps are not followed in sequence, assembly difficulties may occur.

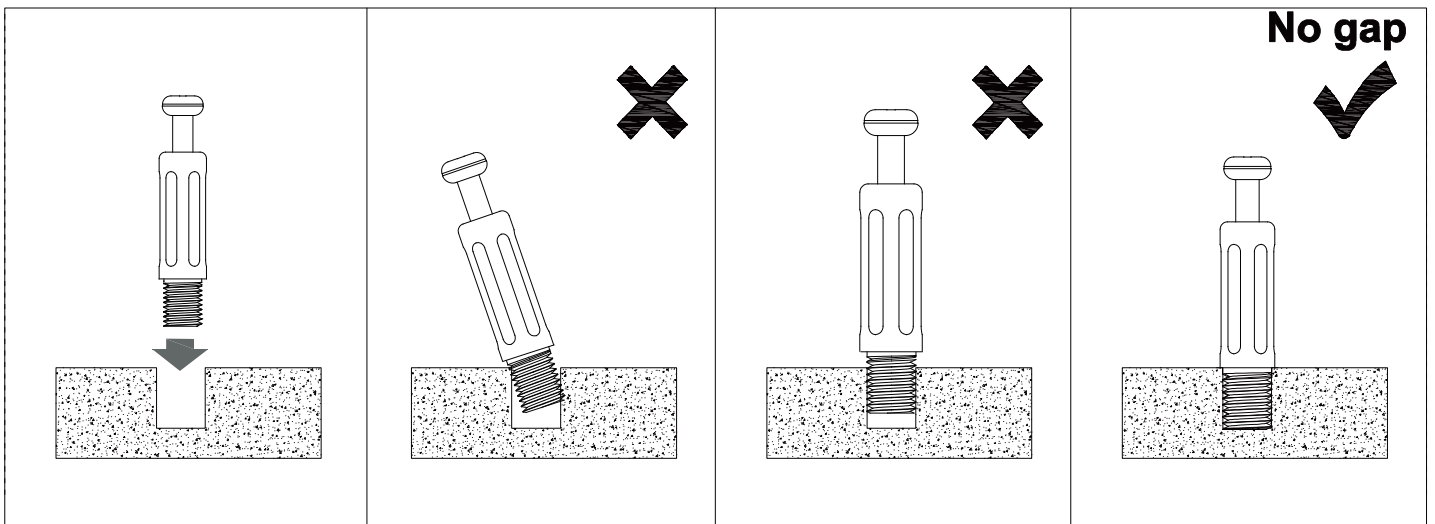
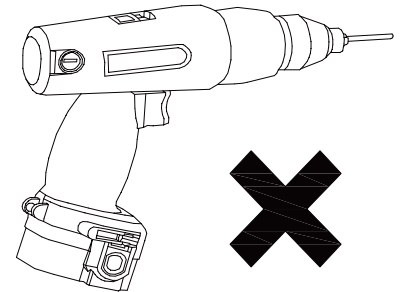

Screw the pin into the hole. Set the cams correctly by aligning the head of the cams with the lock pins. Lock the cam by turning the cam head with a screwdriver until it is tightened. Please do not use an electric screwdriver to assemble the unit.

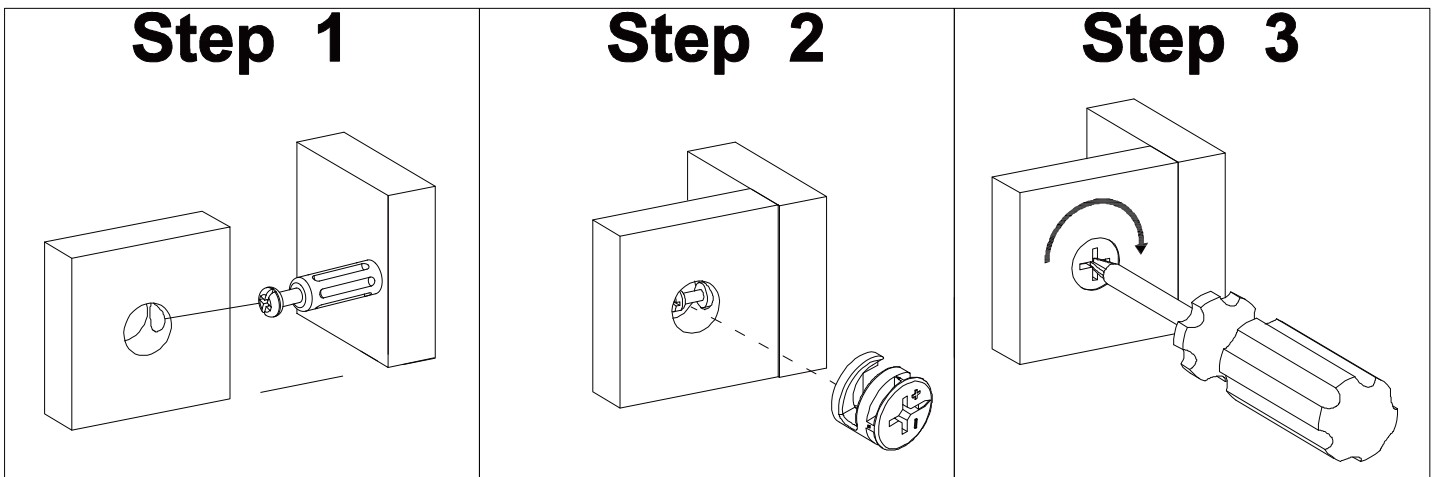

1

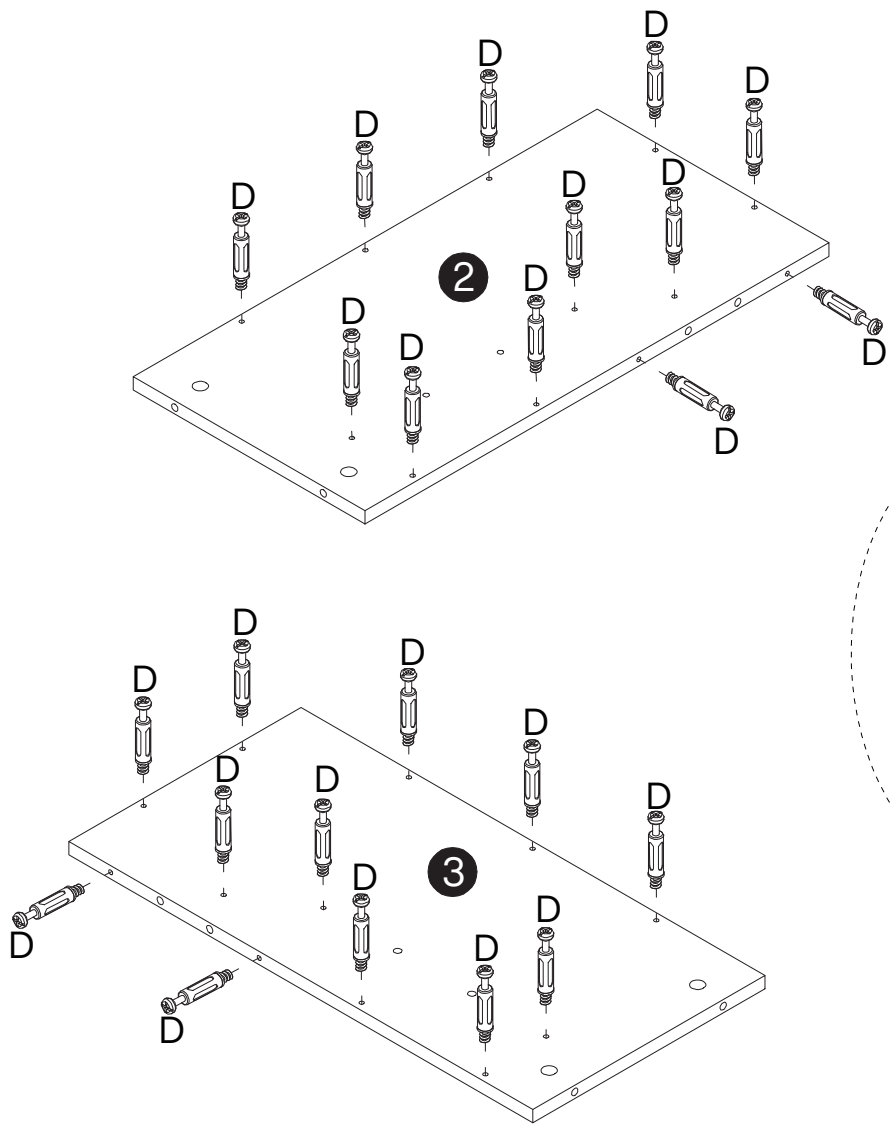

D

ST6X40mm
24 pcs

2

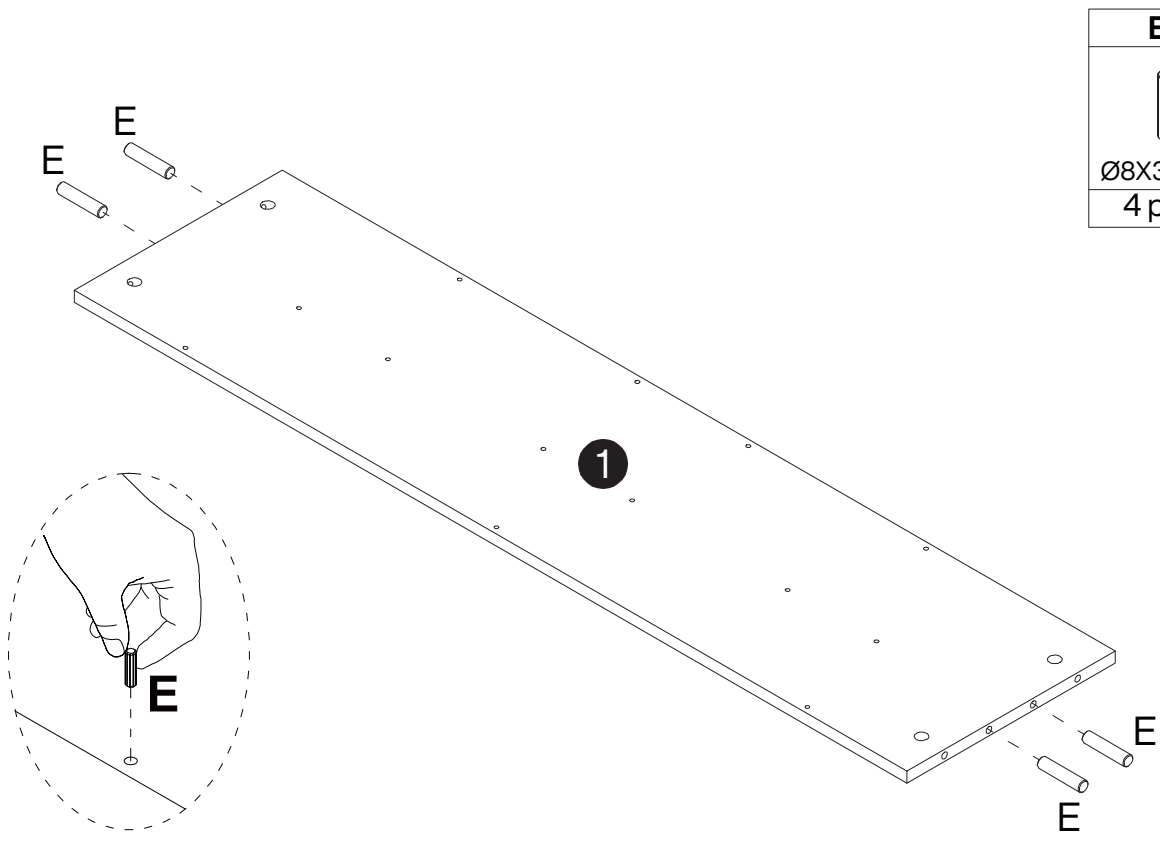

E

Ø8X35mm
4 pcs

3

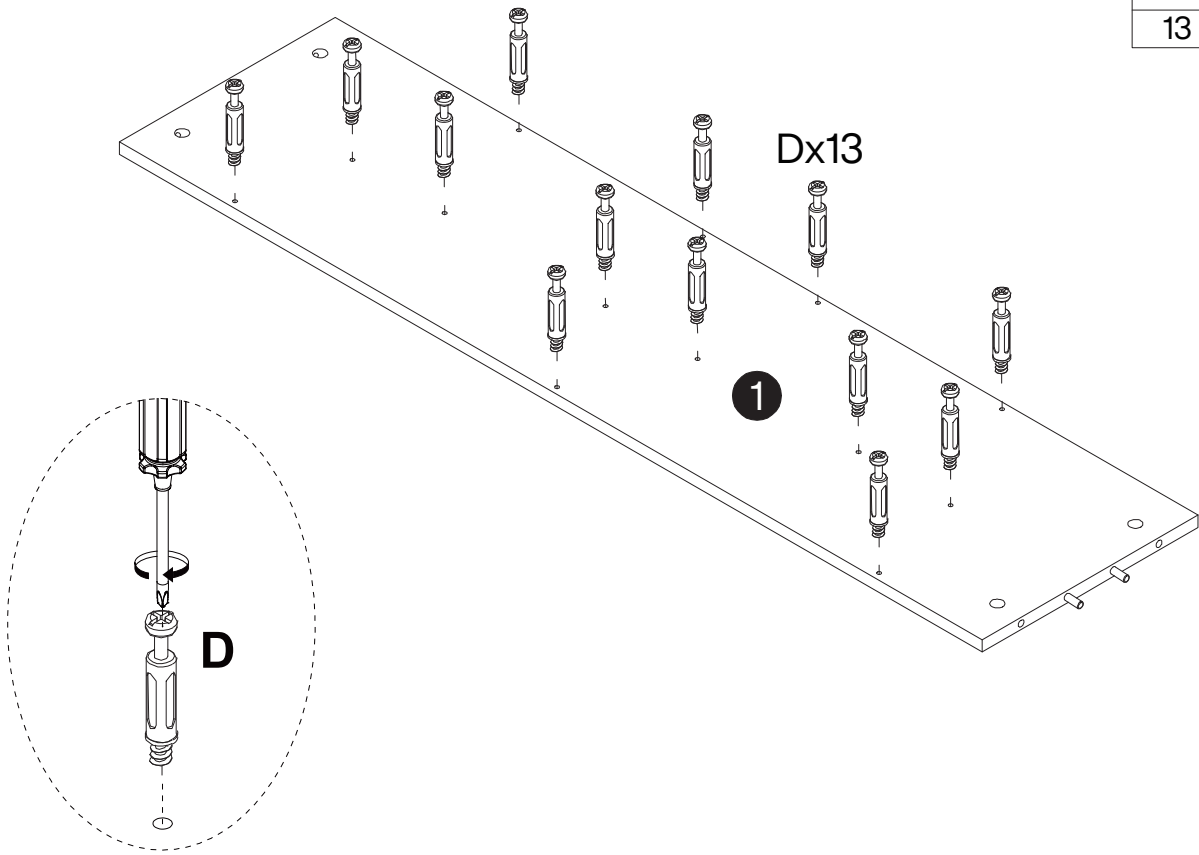
D

ST6X40mm
13 pcs

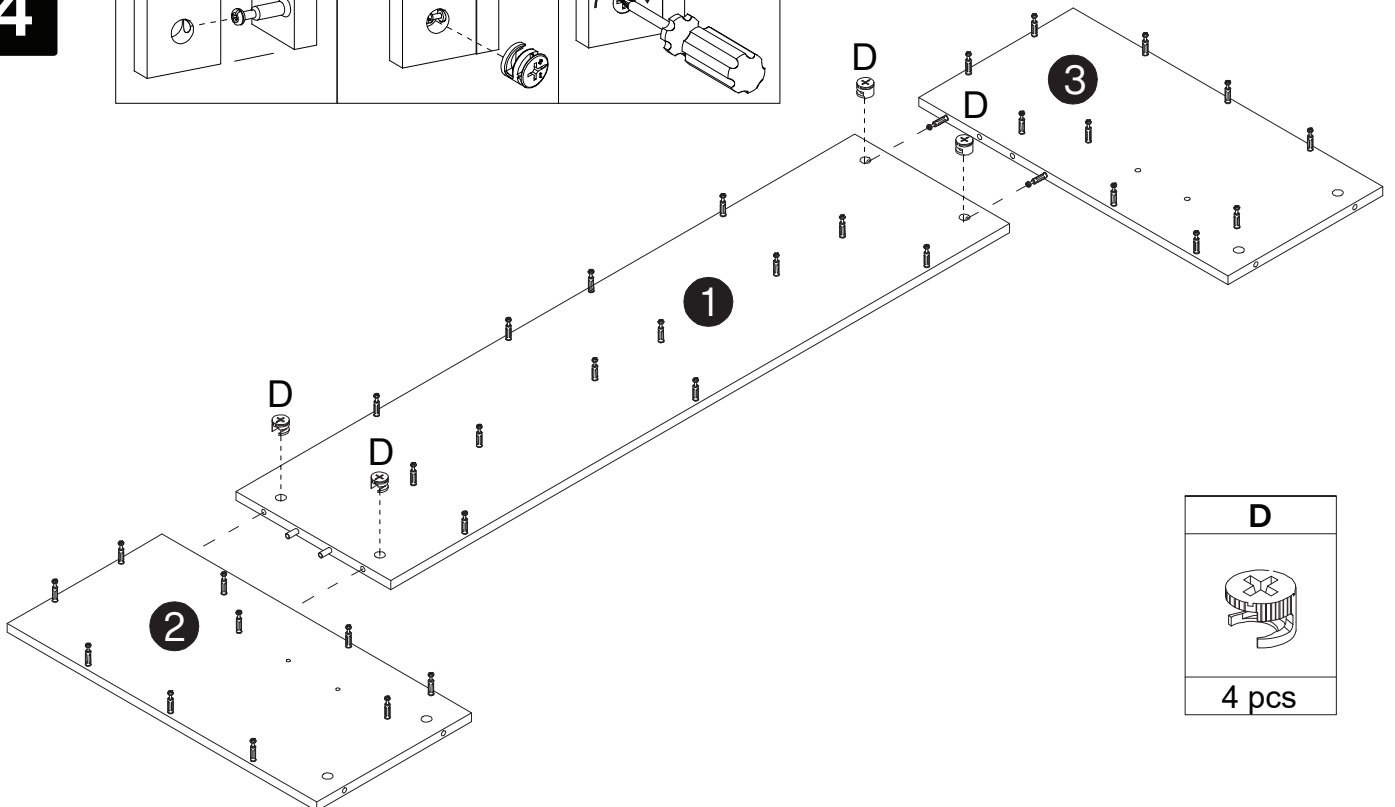
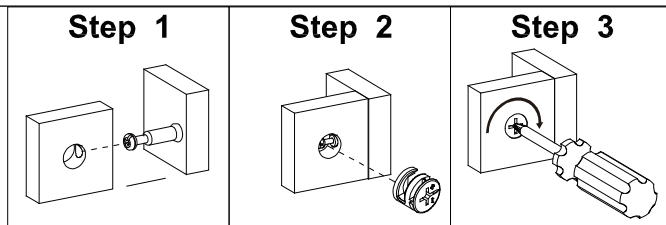



4

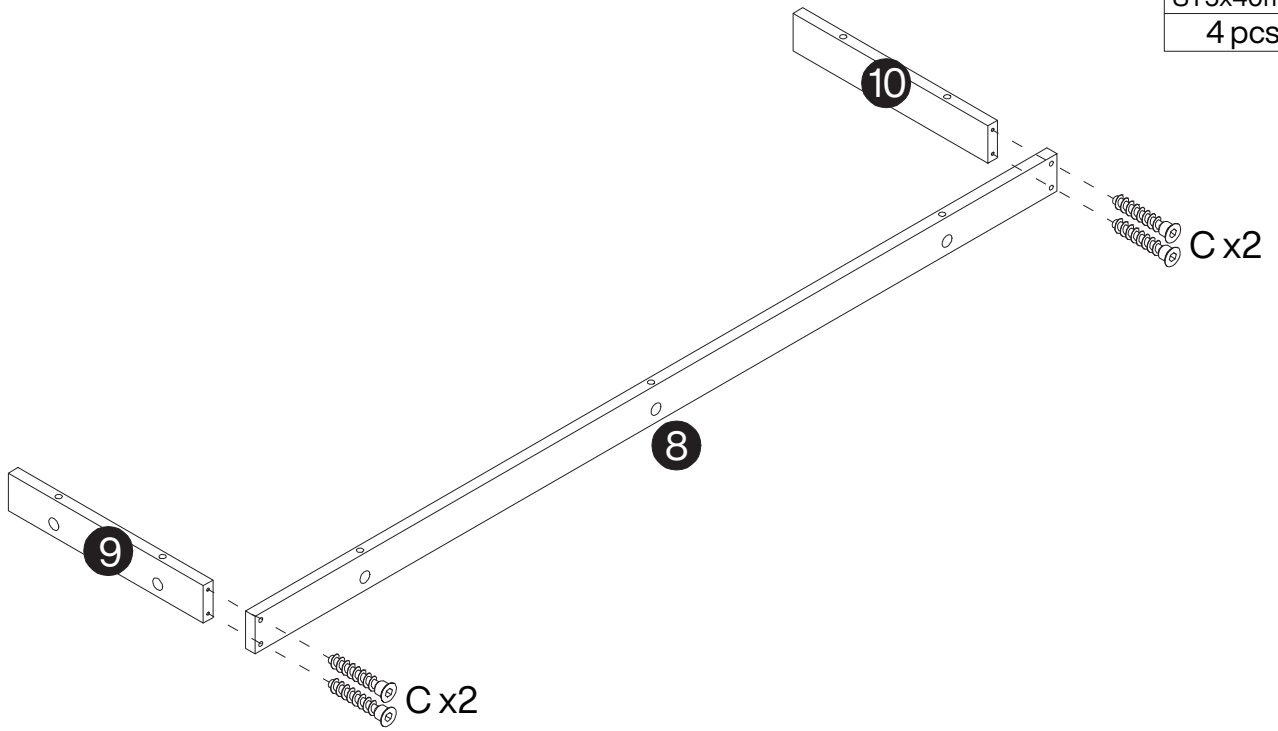

D

4 pcs

5

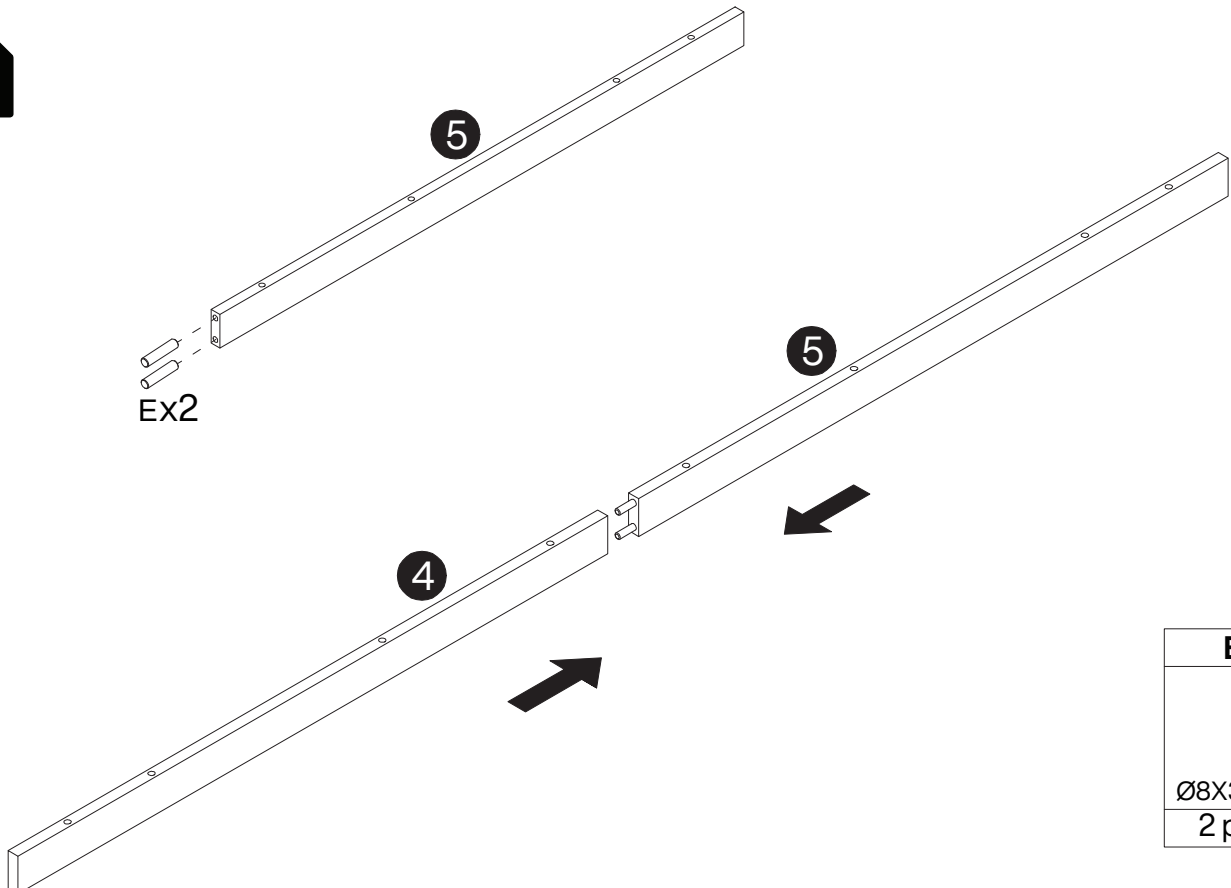

C

ST5x40mm
4 pcs

6



E

Ø8X35mm
2 pcs

7

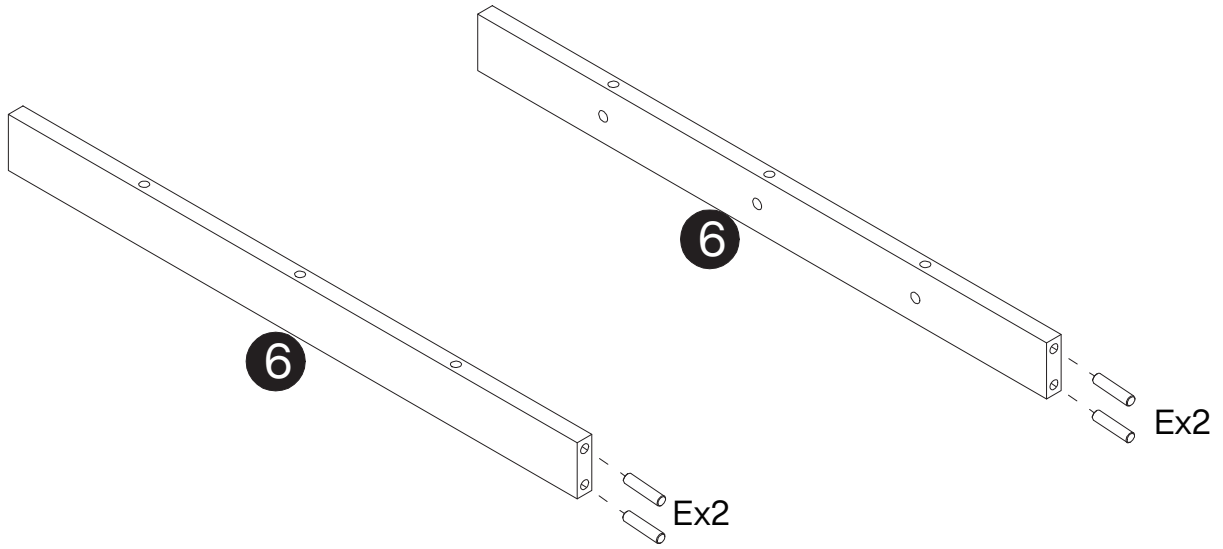
E

Ø8X35mm
4 pcs

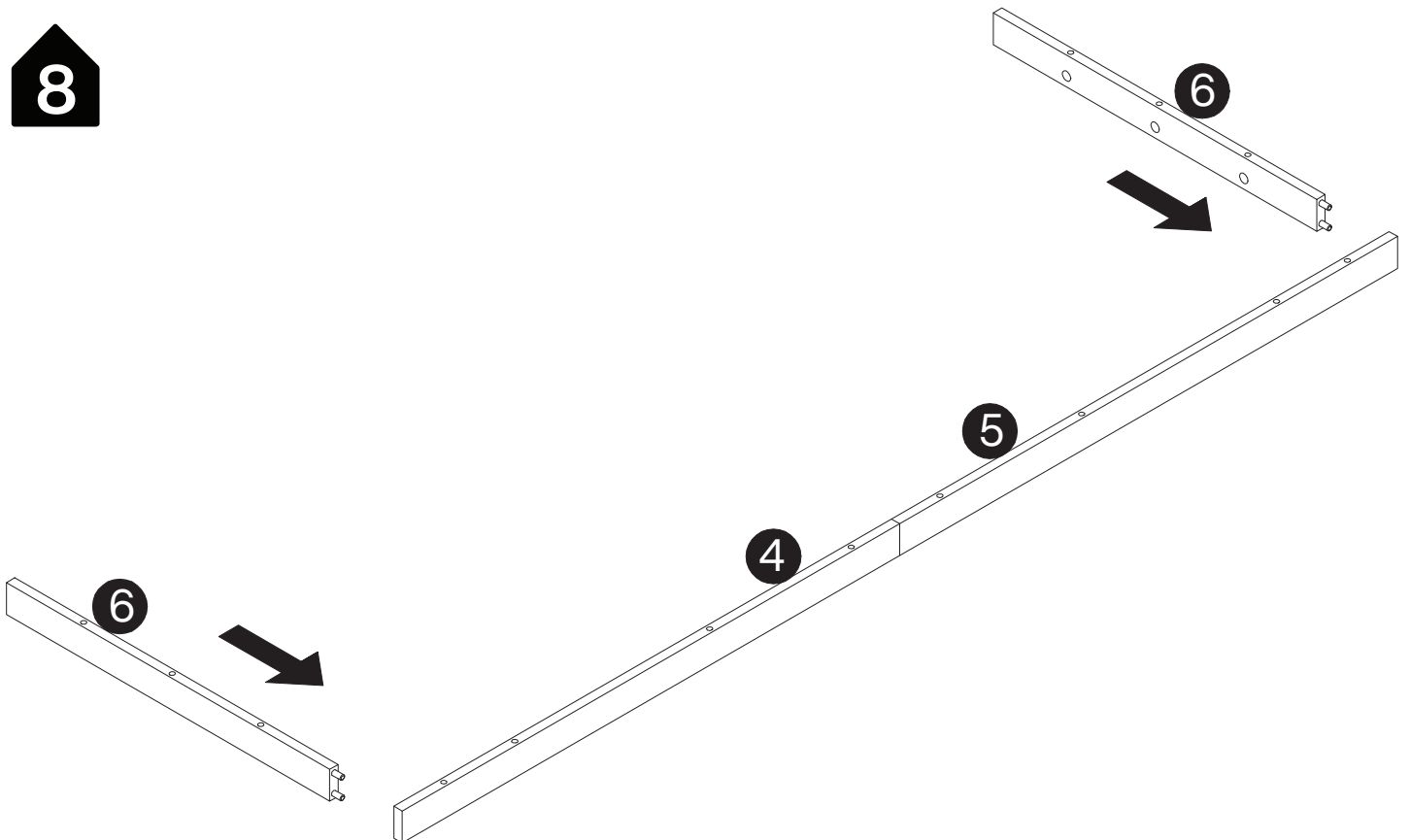

8



9

D

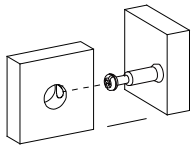
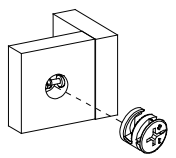
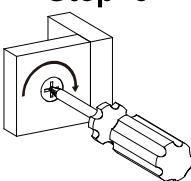
14 pcs

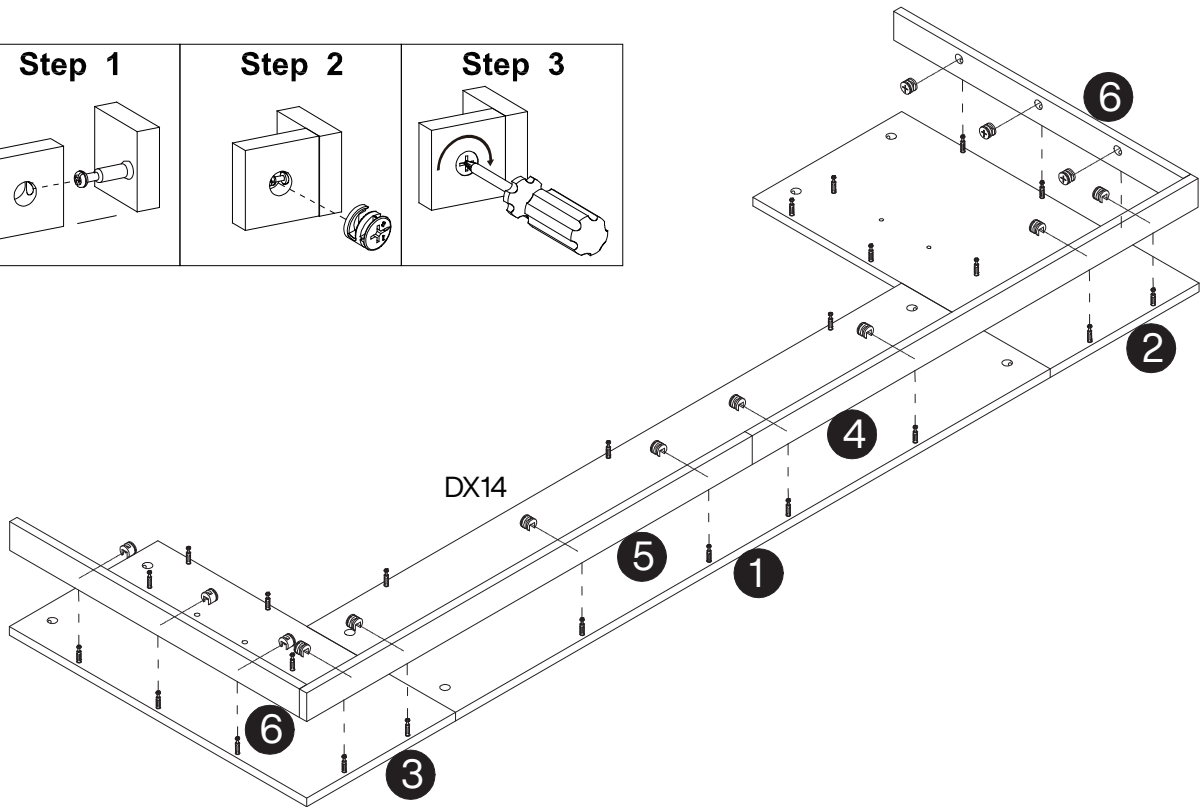
Step 1 	Step 2 	Step 3 
--	--	--



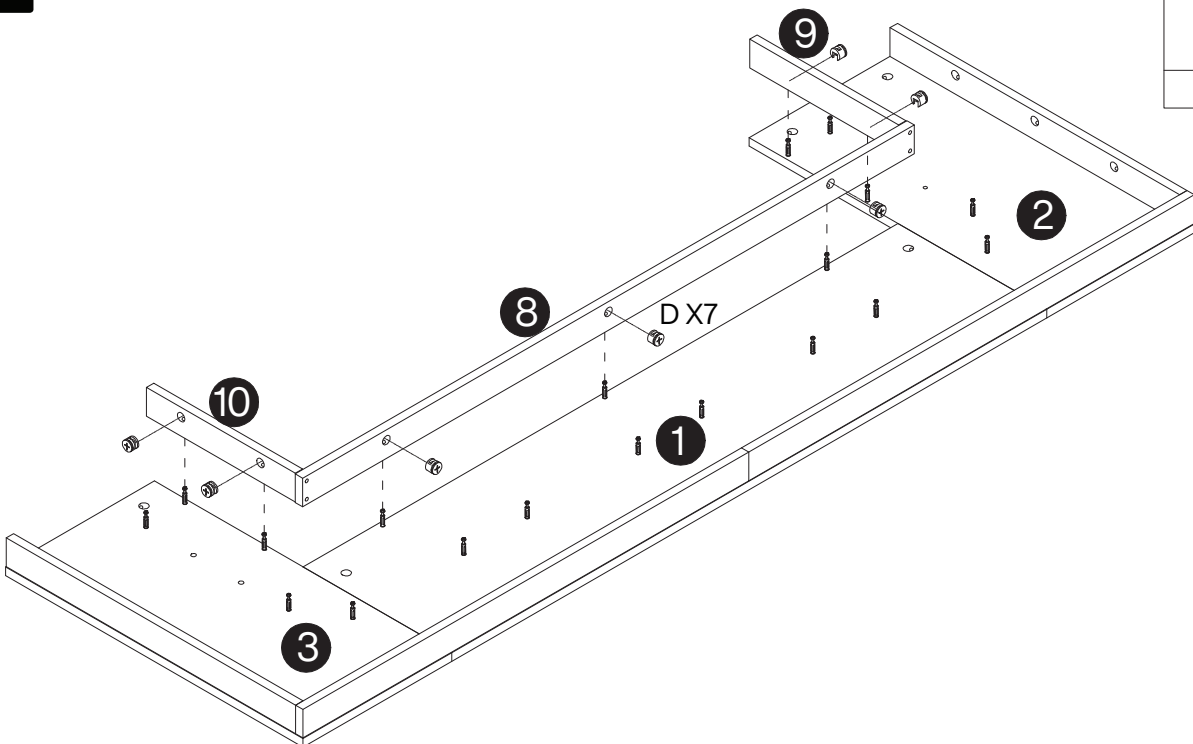

10

D

7 pcs

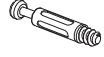

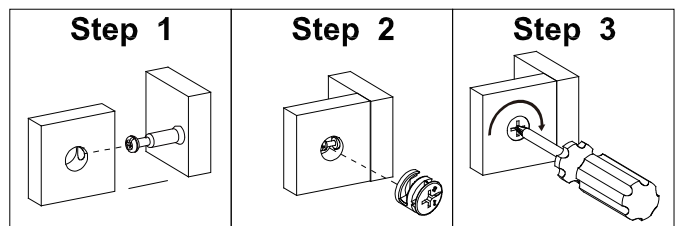
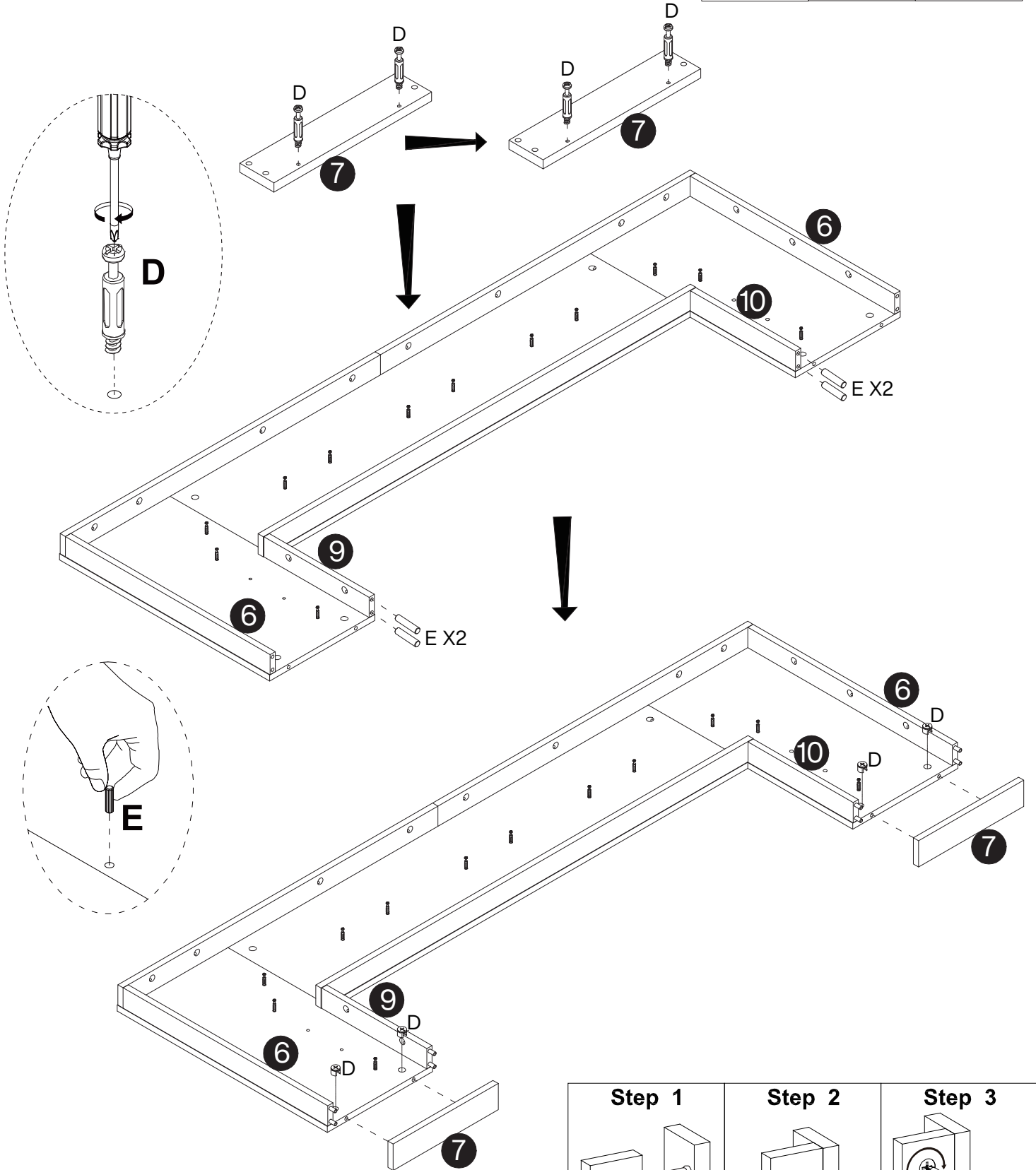

11

D	D	E
		
4 pcs	ST6X40mm 4 pcs	Ø8X35mm 4 pcs

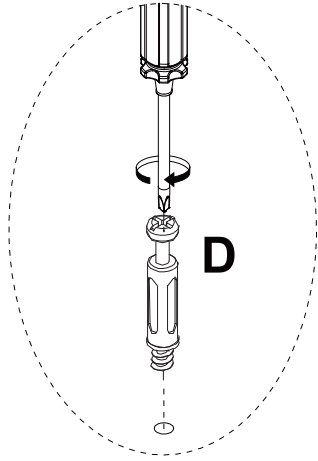

12

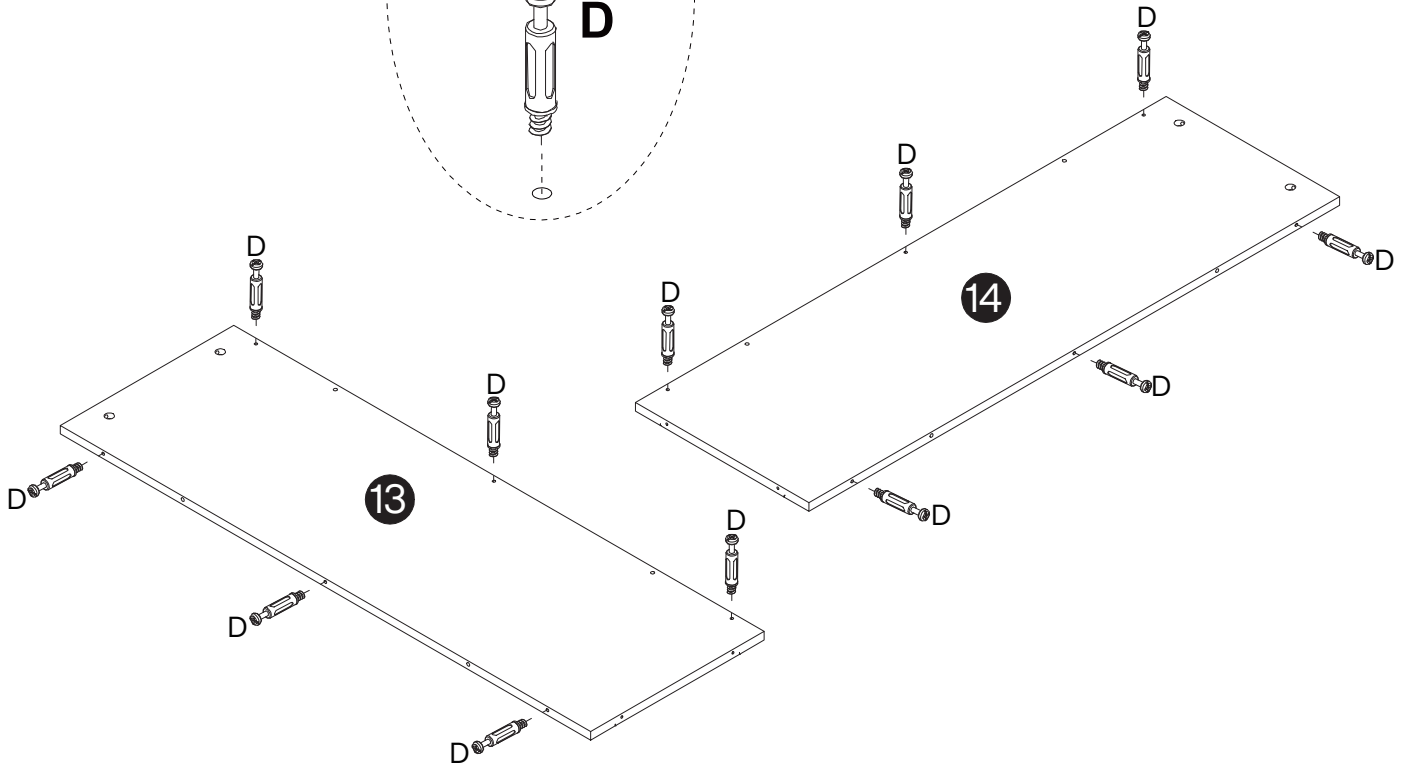

D

ST6X40mm
12 pcs



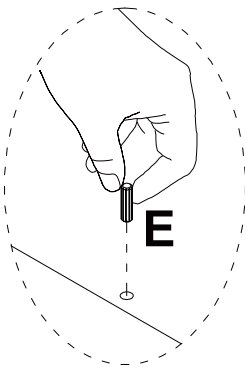

13

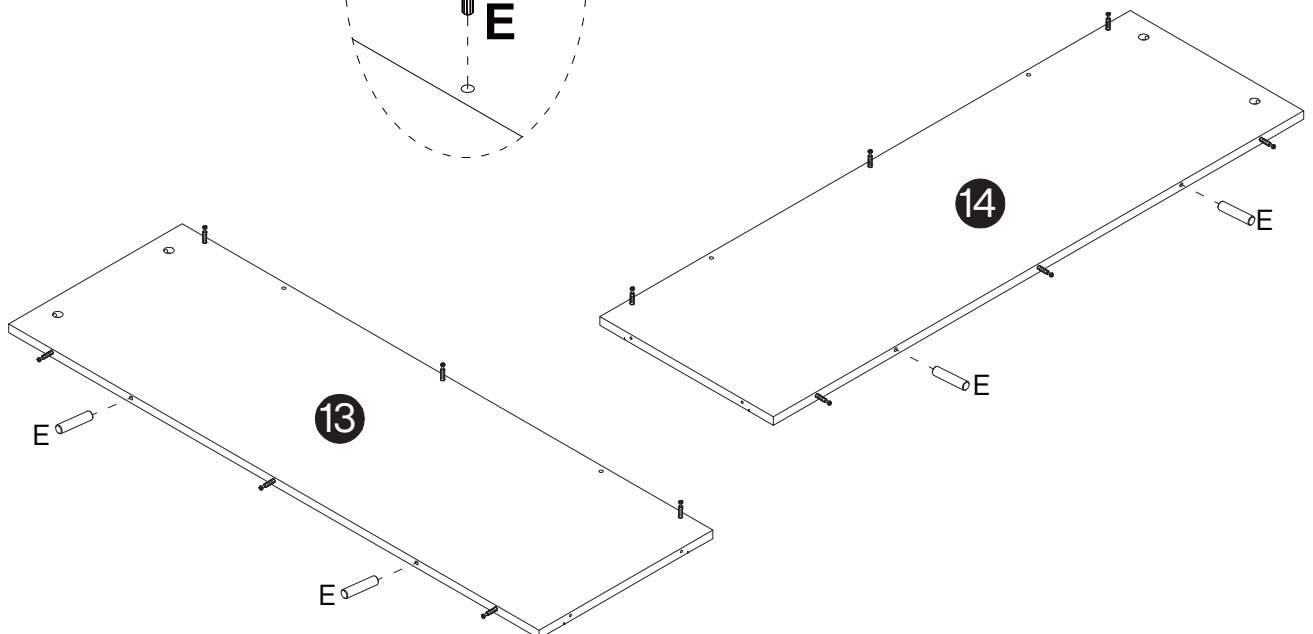

E

Ø8X35mm
4 pcs

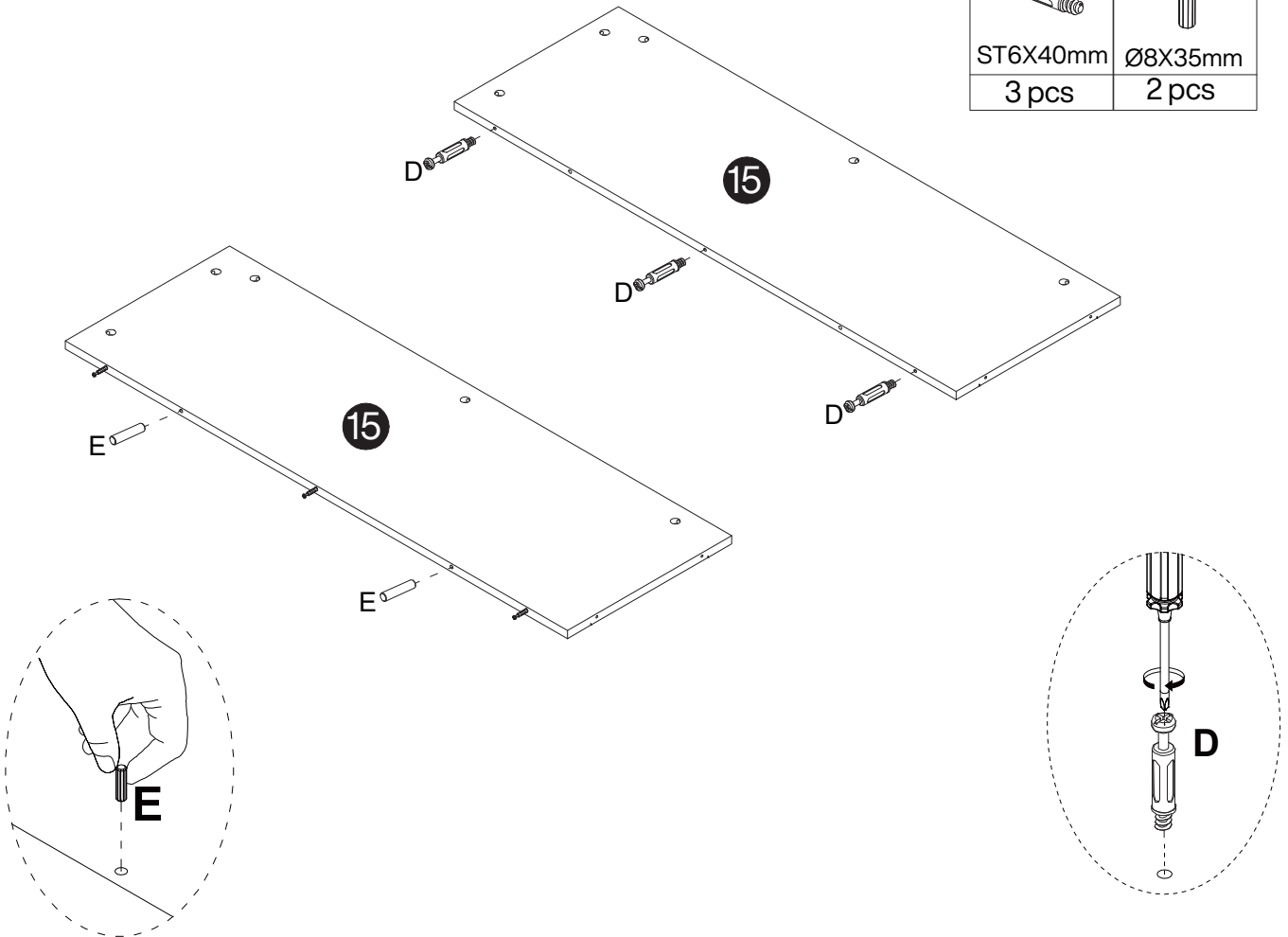

14

D	E
	
ST6X40mm	Ø8X35mm
3 pcs	2 pcs



15

D

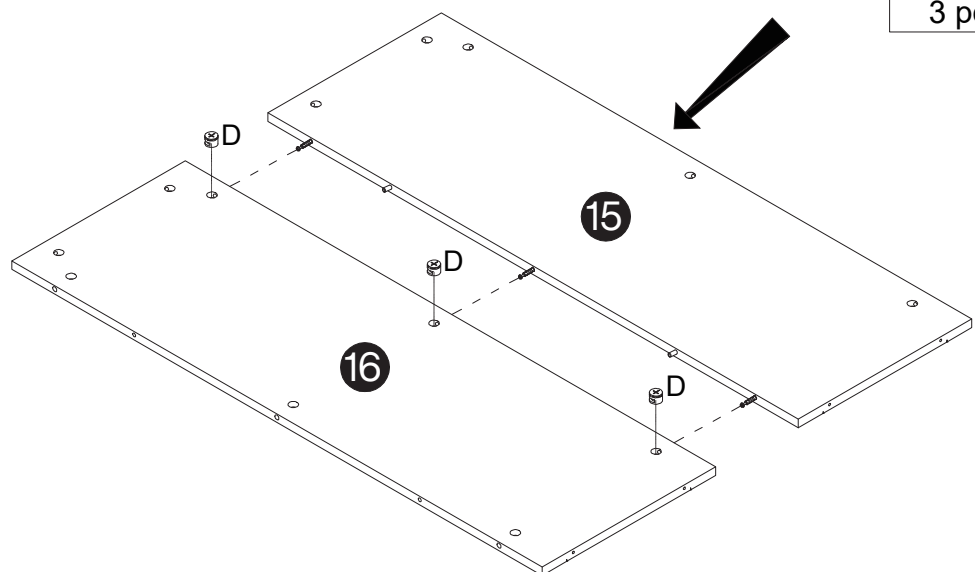
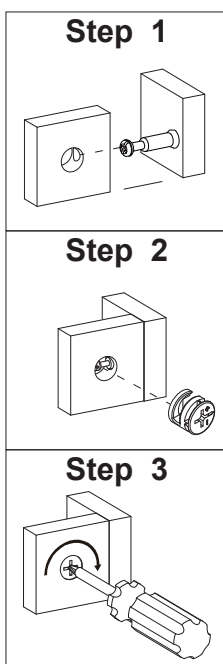
3 pcs

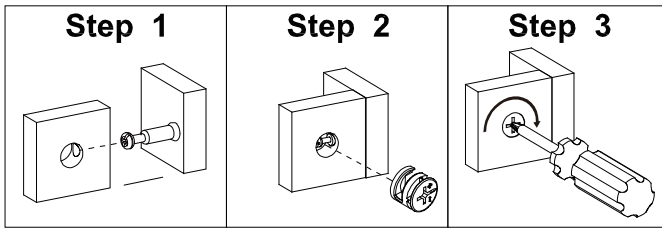

16

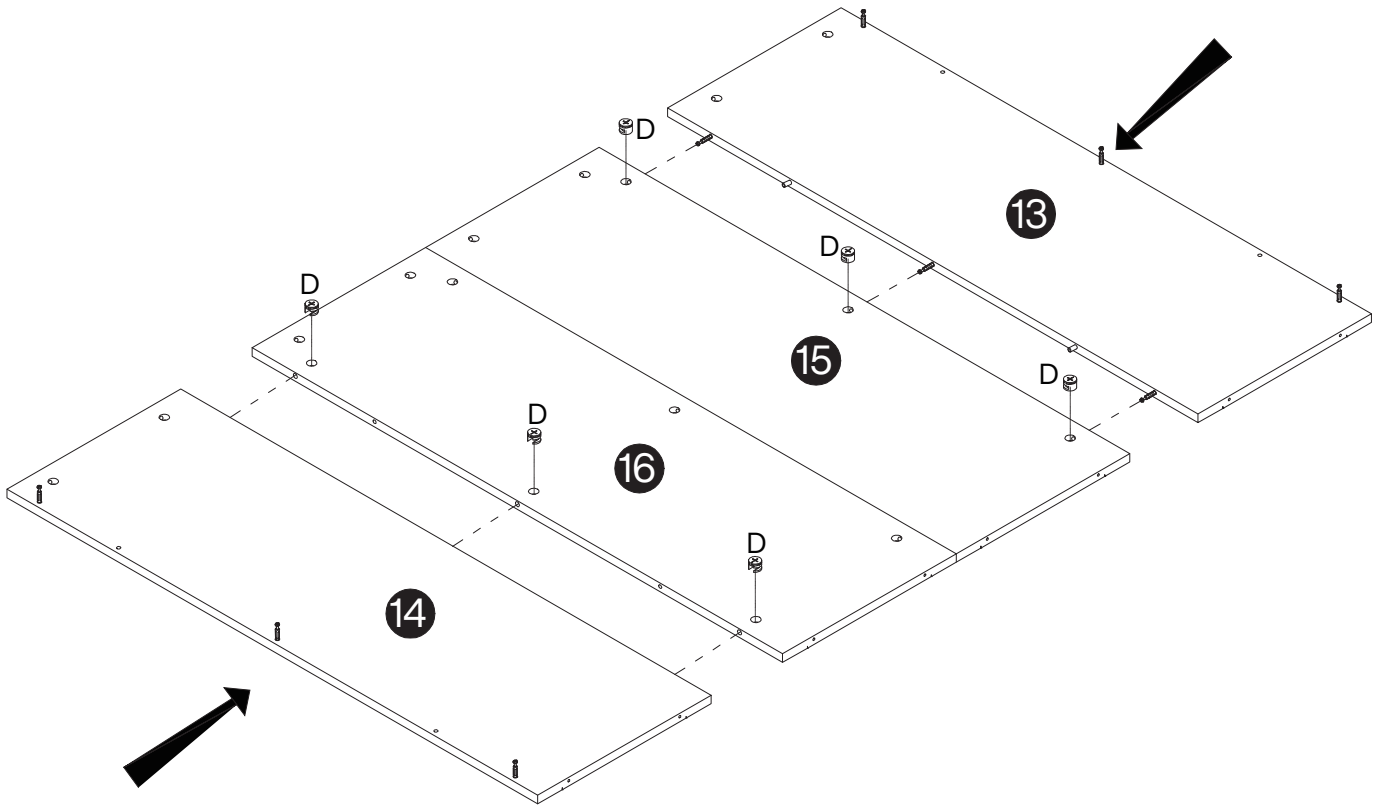

D
6 pcs



17

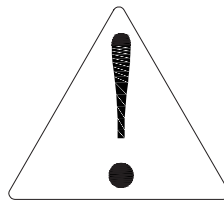

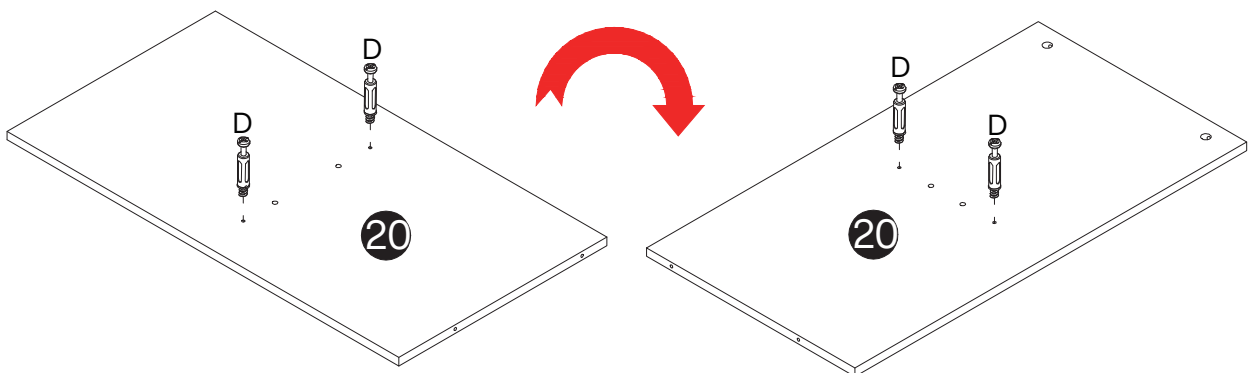

D
ST6X40mm
4 pcs

Note: Part #20 requires the installation of screws #D on both the front and back sides.



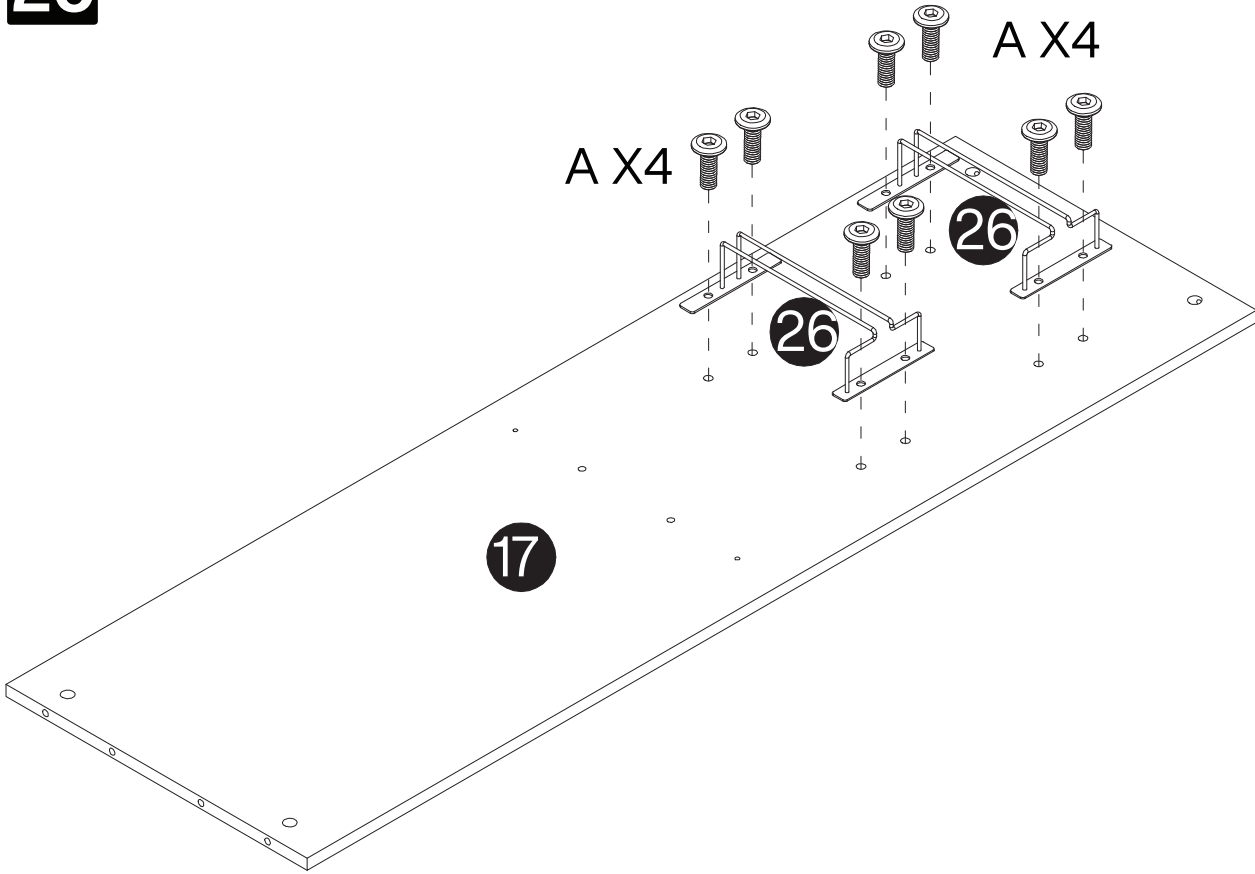

20

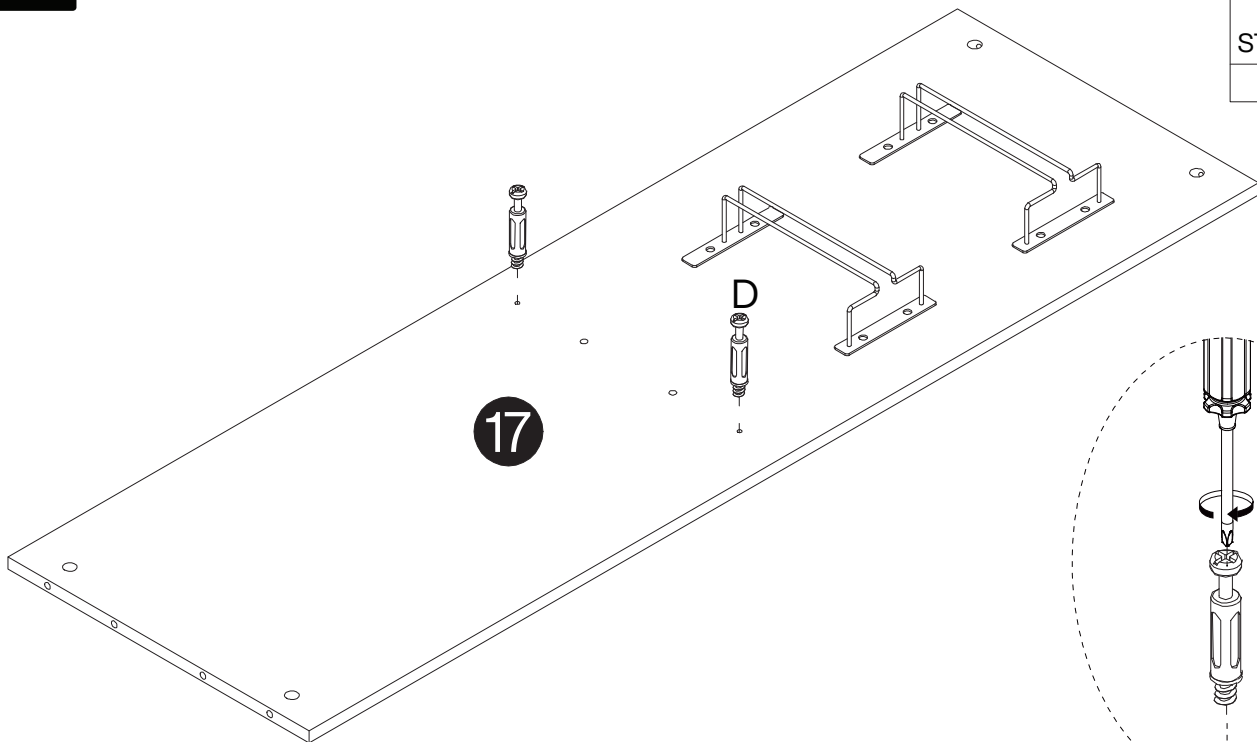

A

M6X10mm
8 pcs

21

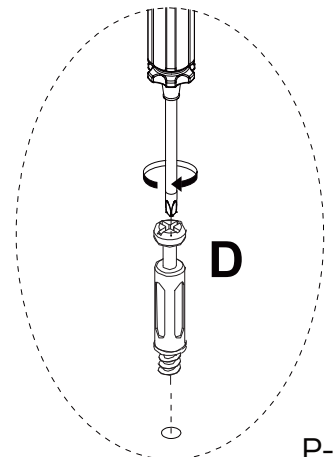

D

ST6X40mm
2 pcs

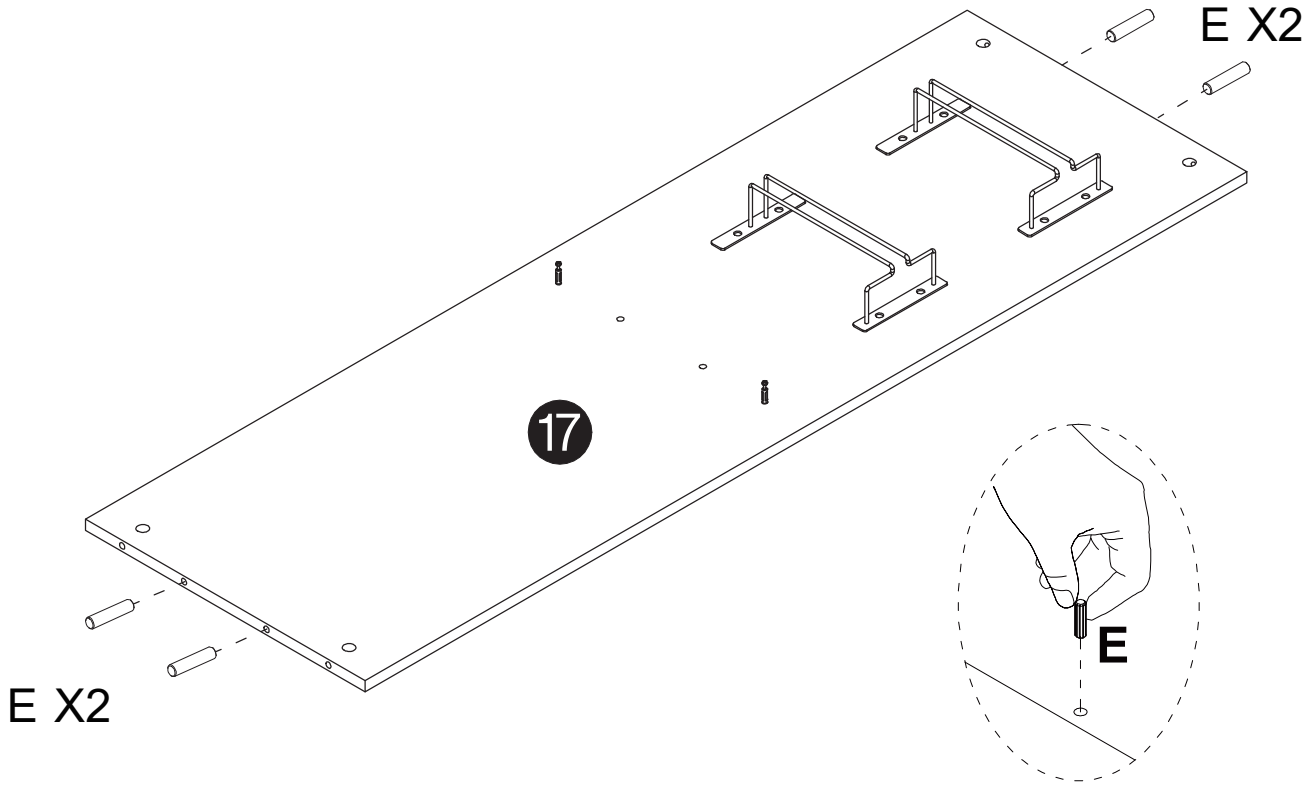

22

E

Ø8X35mm
4 pcs

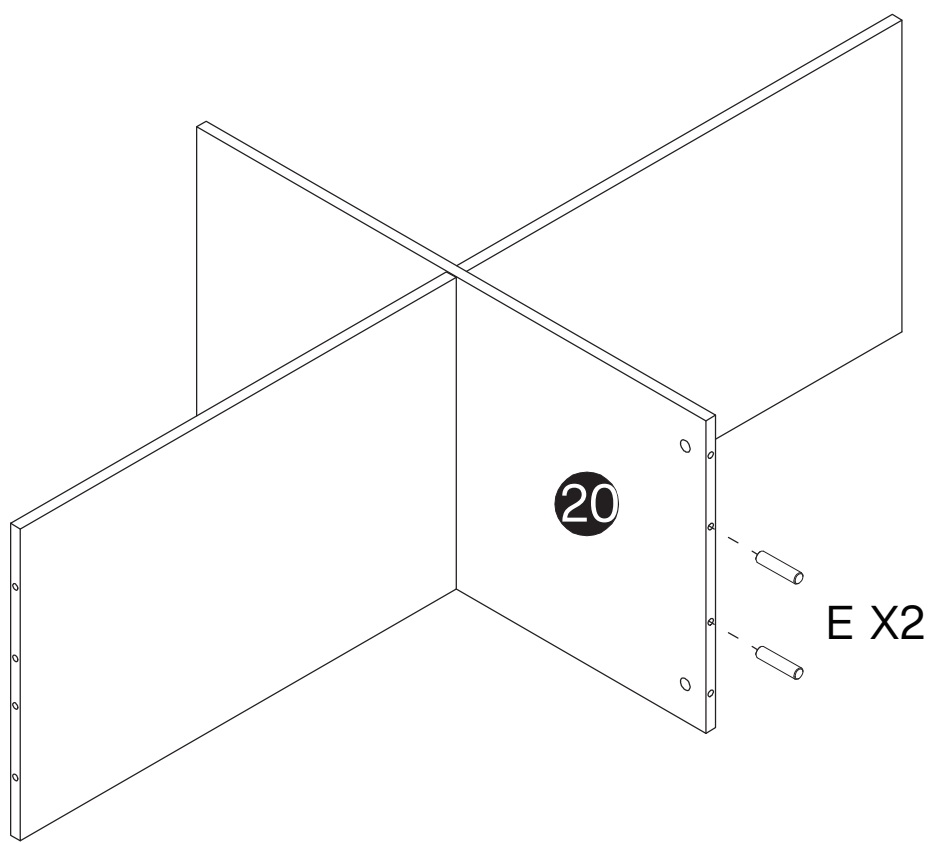

23

E

Ø8X35mm
2 pcs



24

D

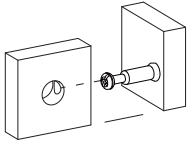
2 pcs

Step 1

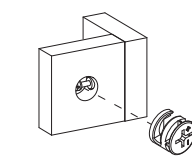

Step 2



Step 3

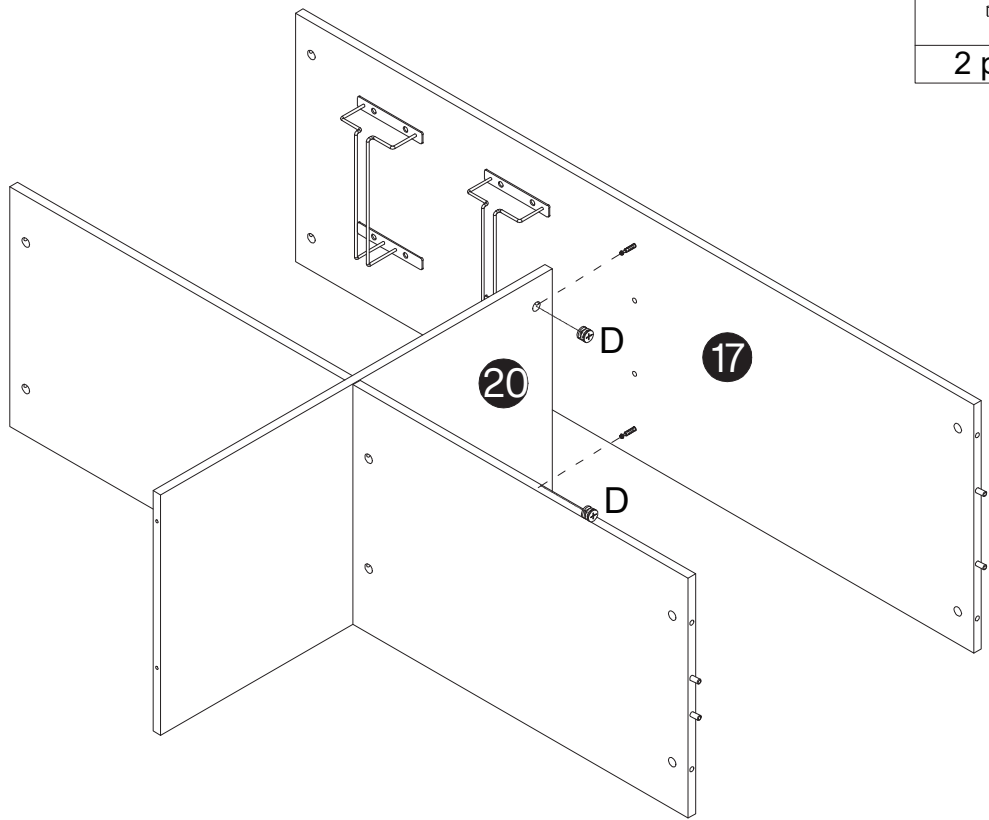
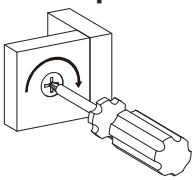

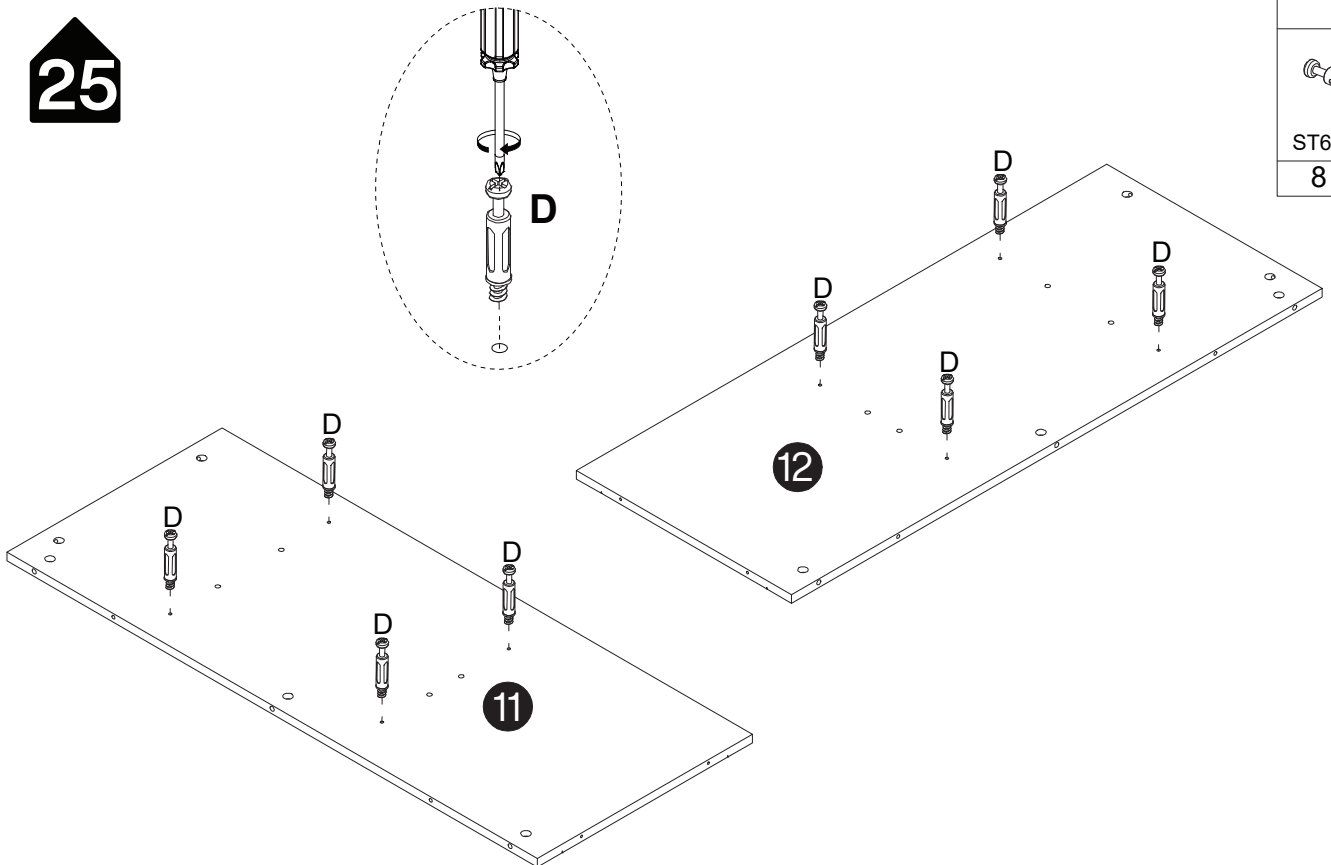

25

D

ST6X40MM
8 PCS

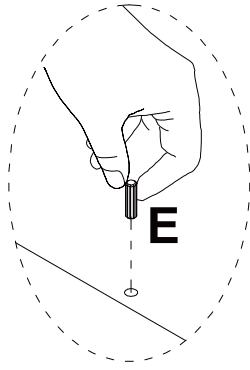

26

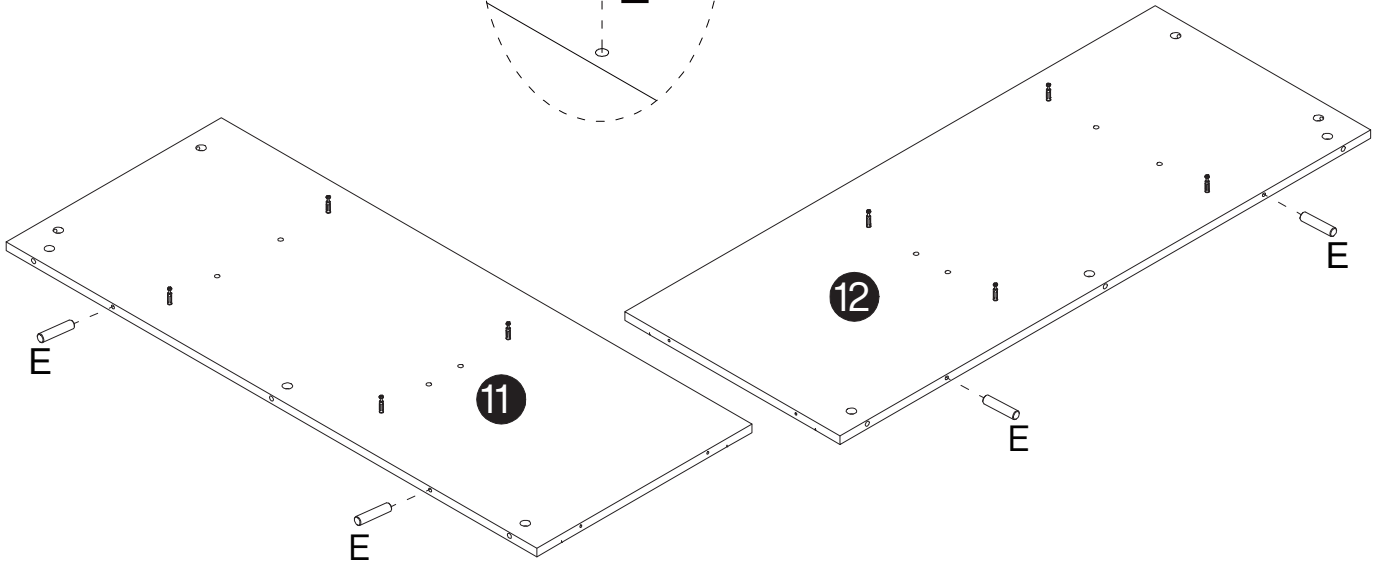

E

Ø8X35mm
4 pcs

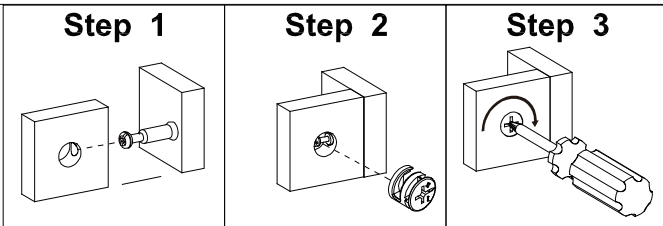

27

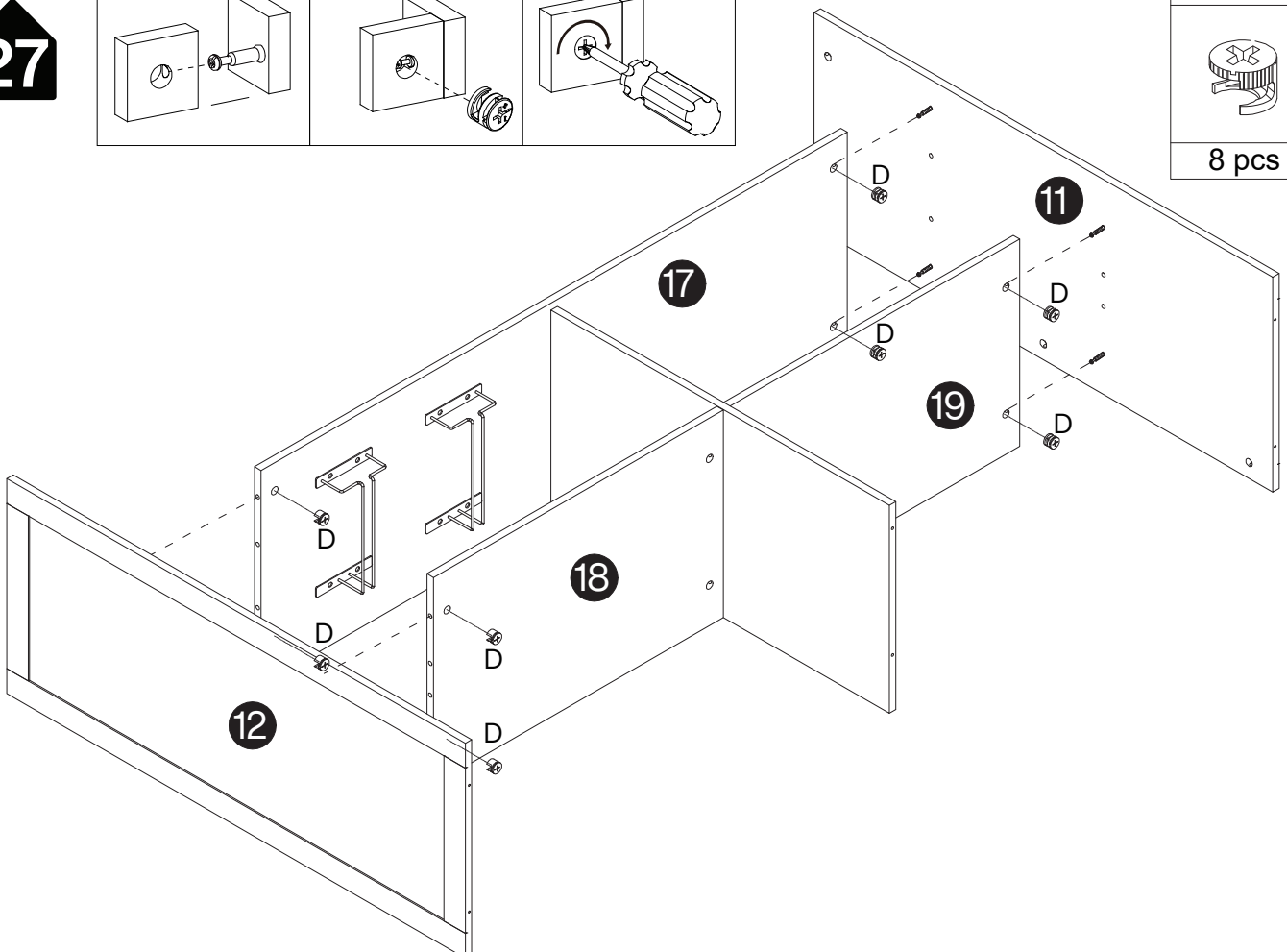

D

8 pcs

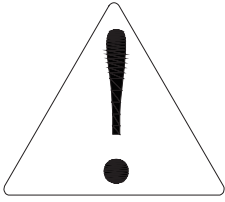

28

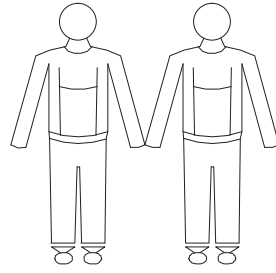

Note that two people are required to install this step together.



D
6 pcs

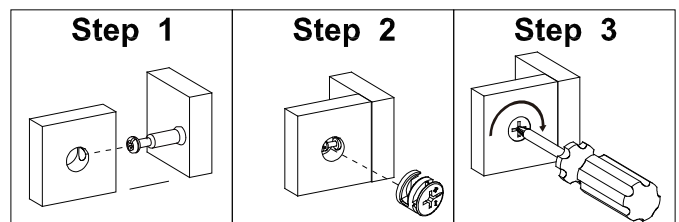
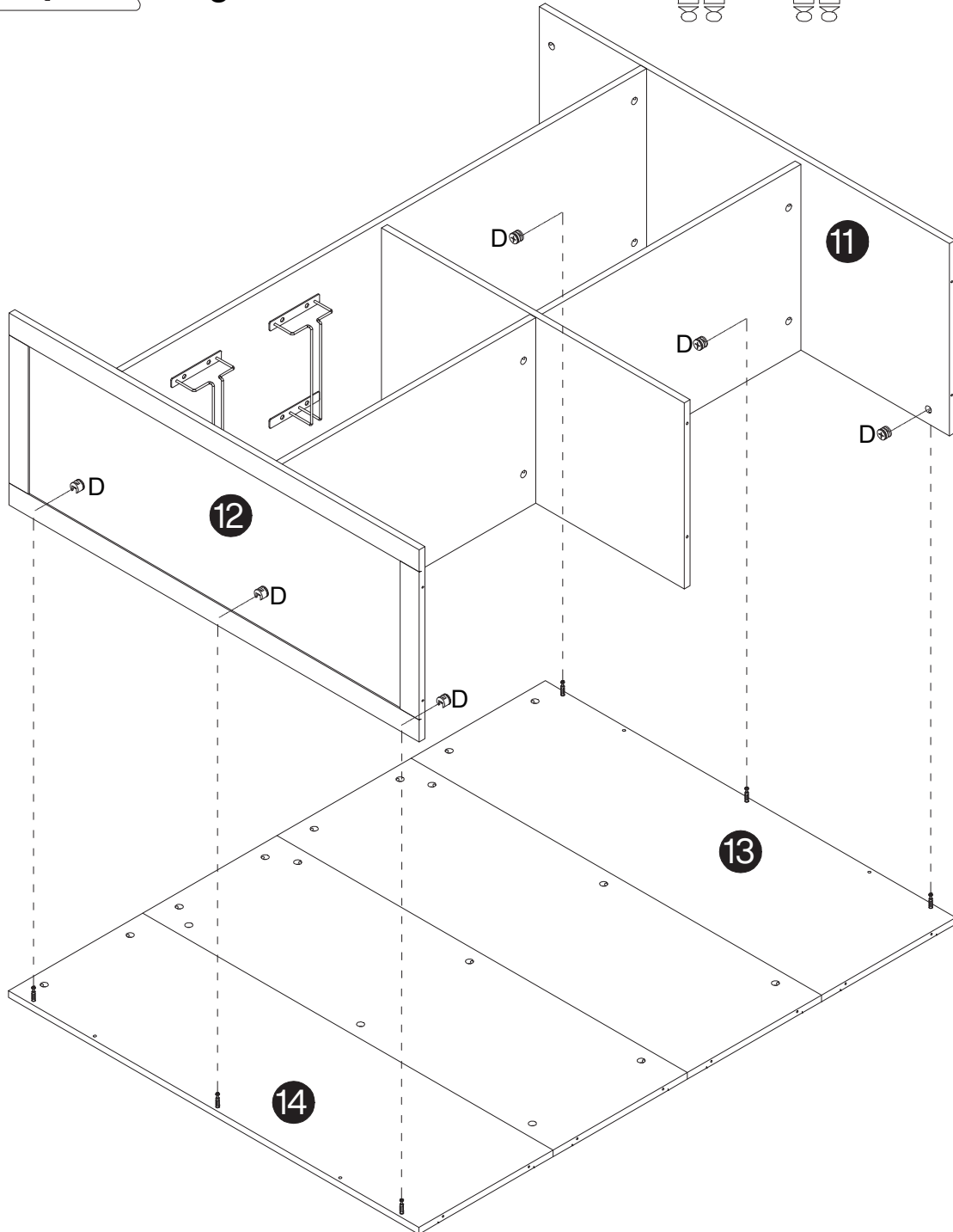

C

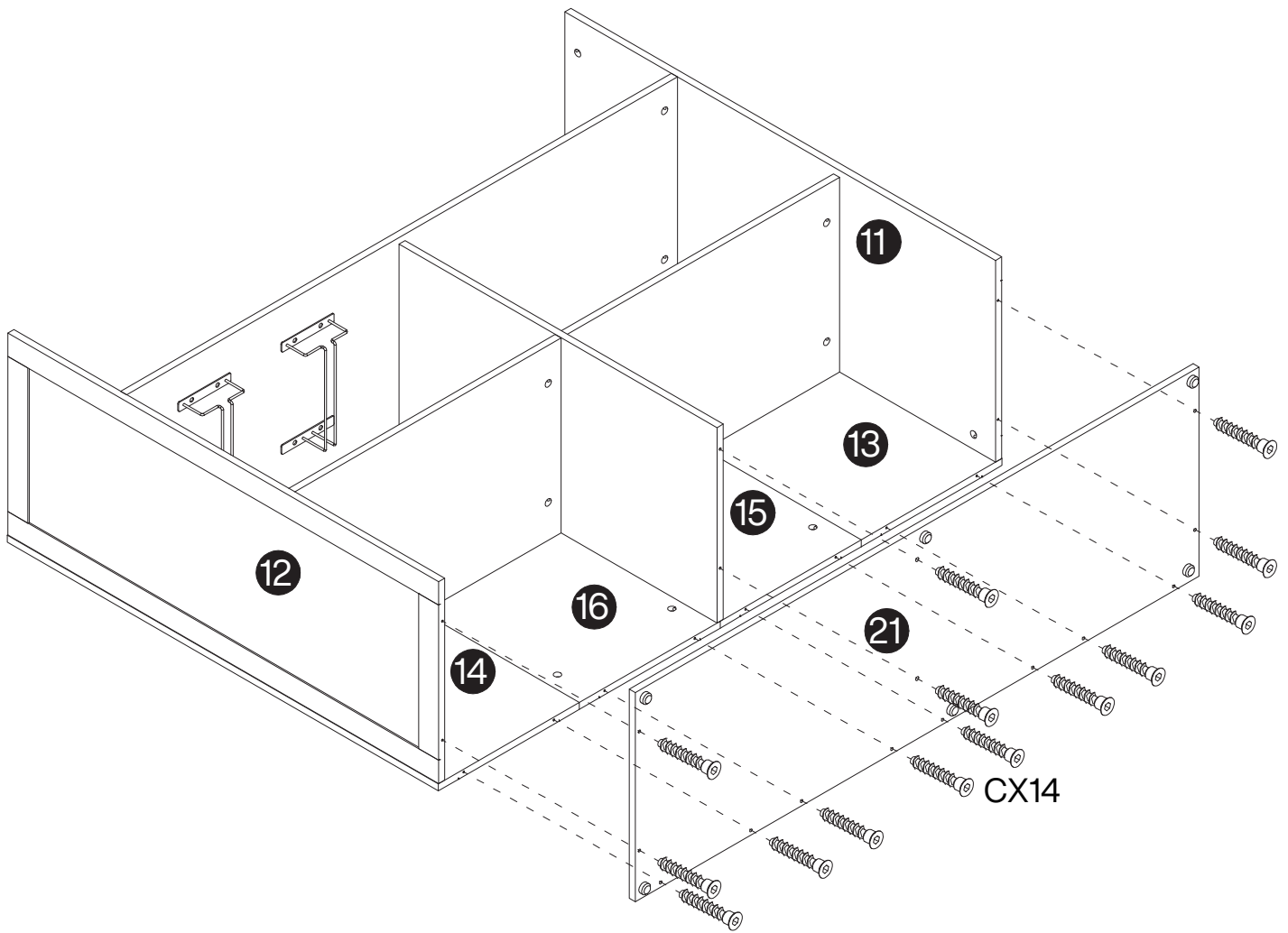
ST5X40mm
14 pcs

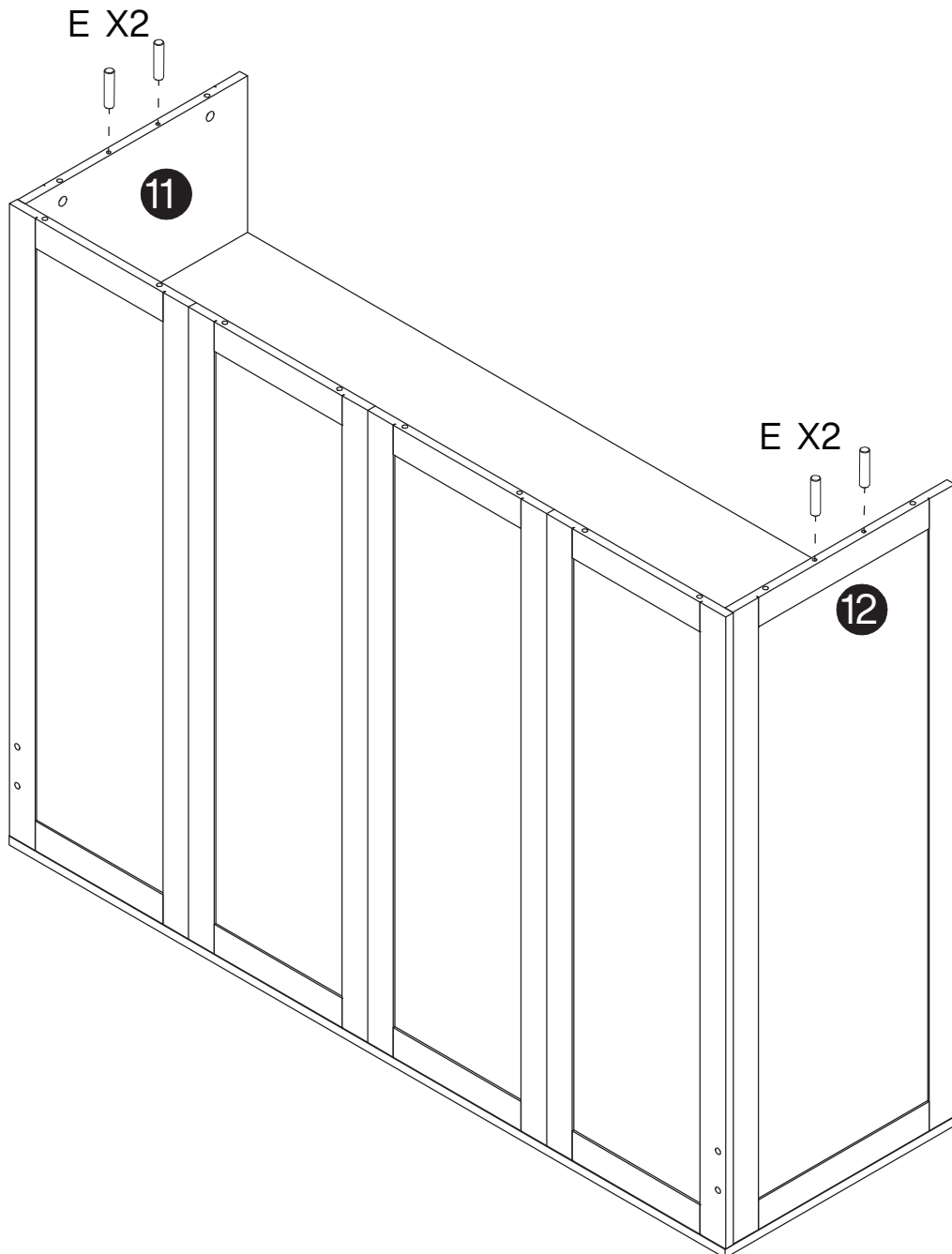

E

Ø8X35mm
4 pcs

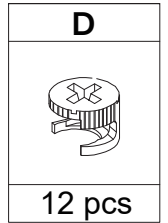
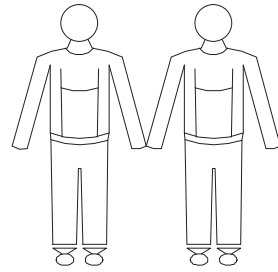



31

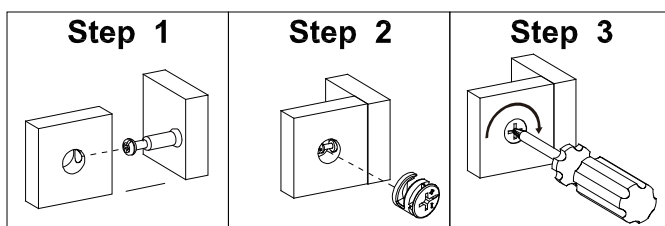
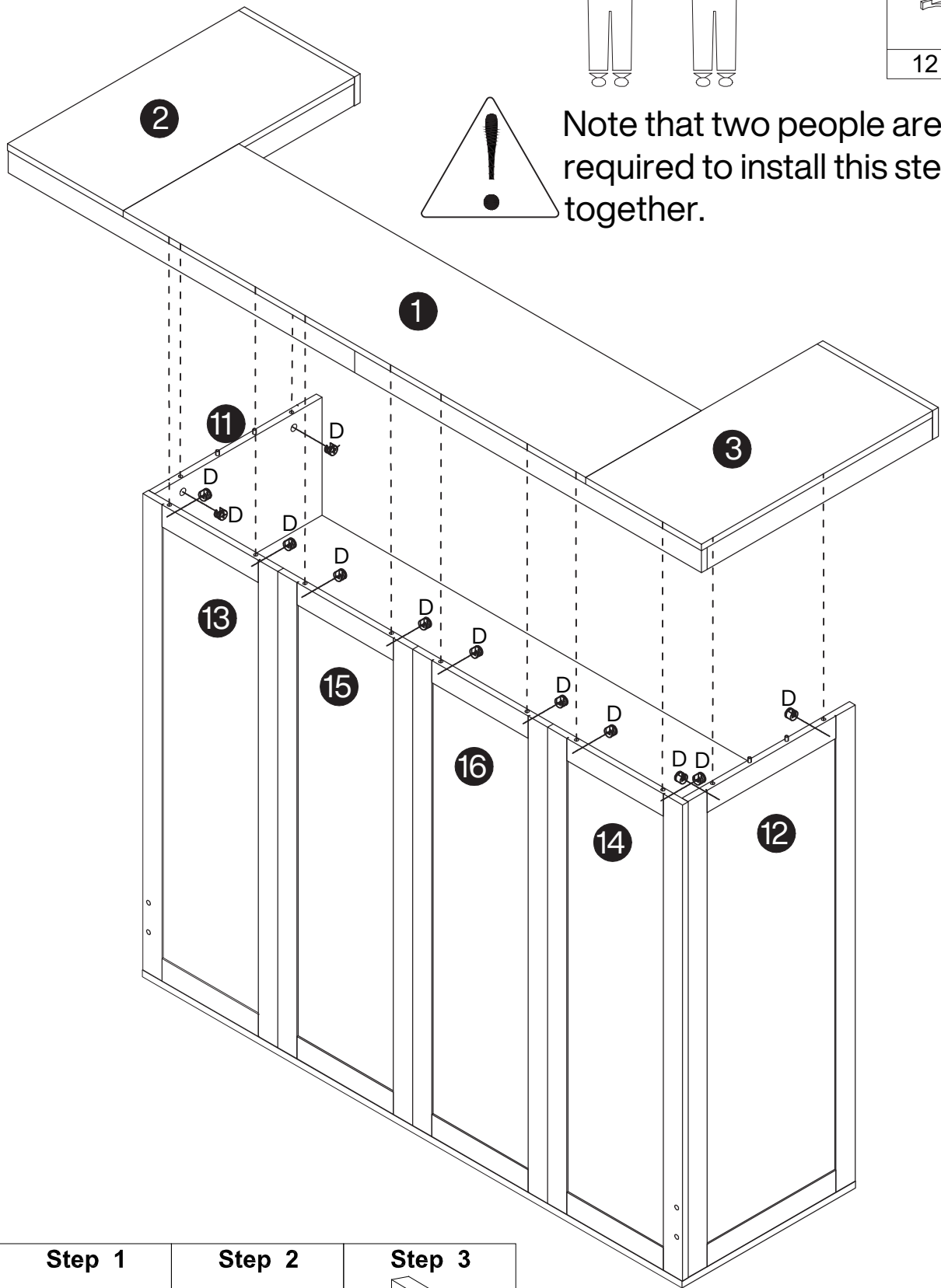

Note that two people are required to install this step together.



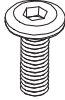

32

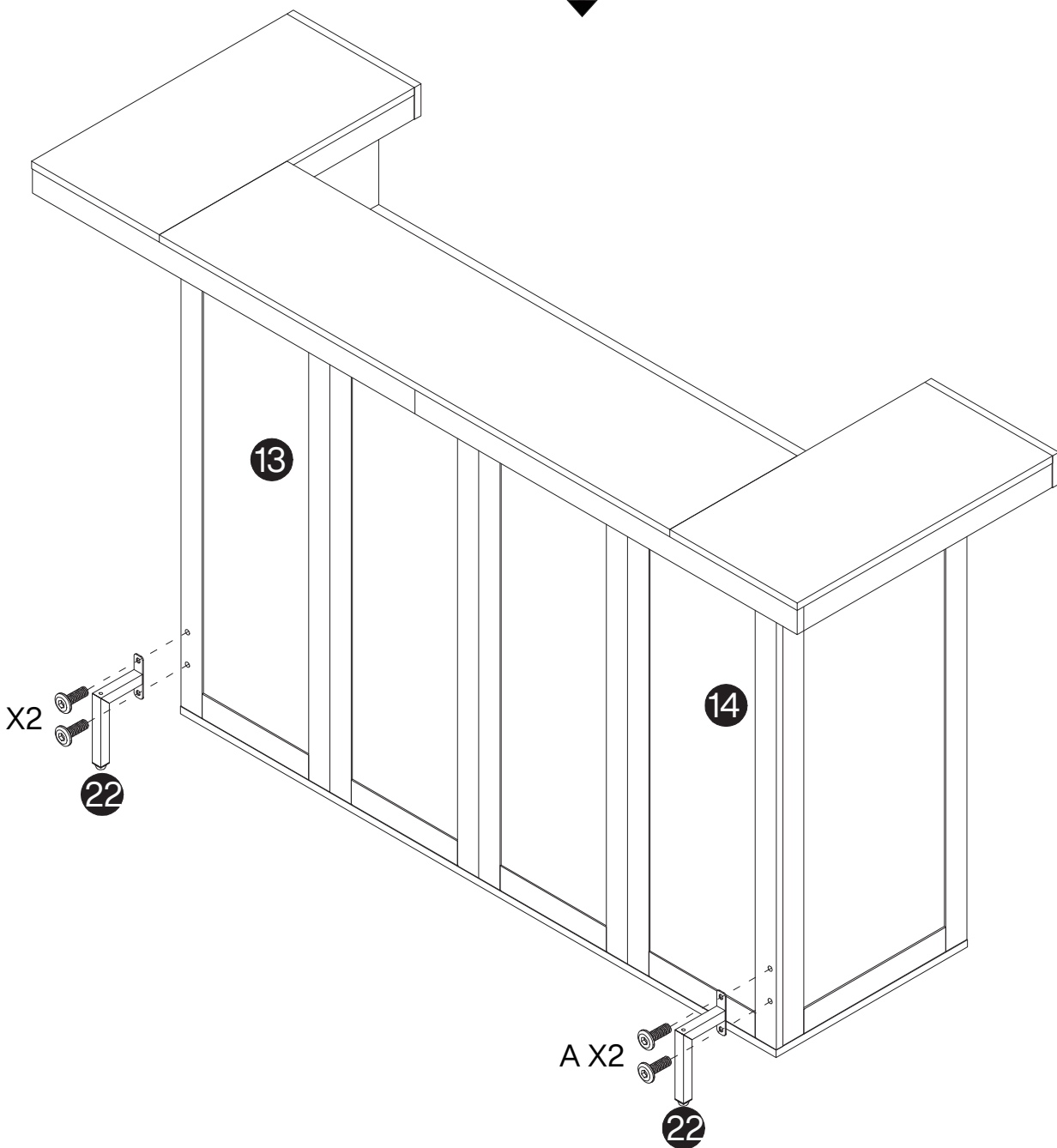
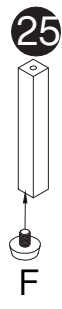
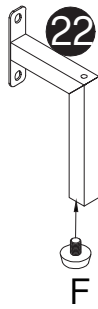
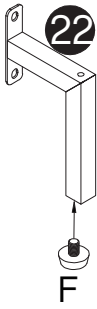
A	F
	
M6X10mm	M8
4 pcs	3 pcs



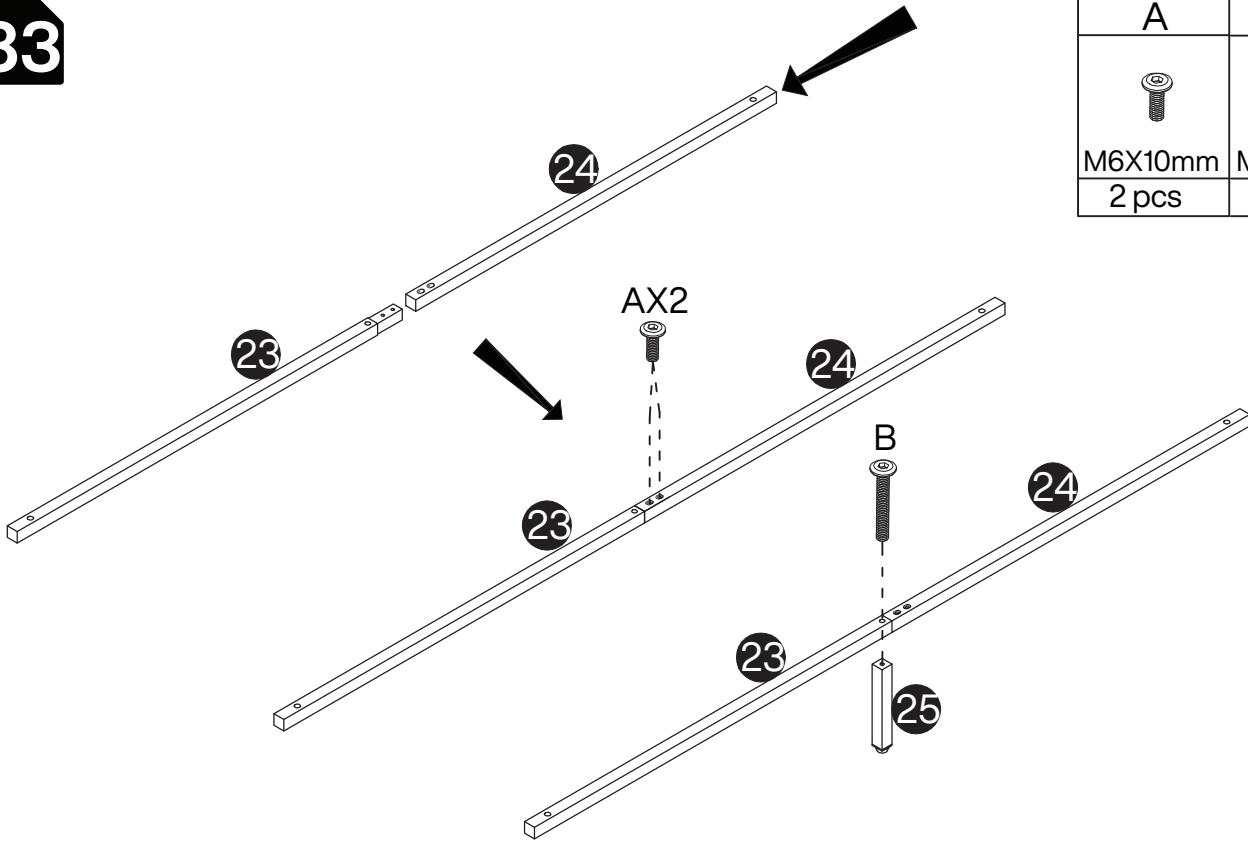

33

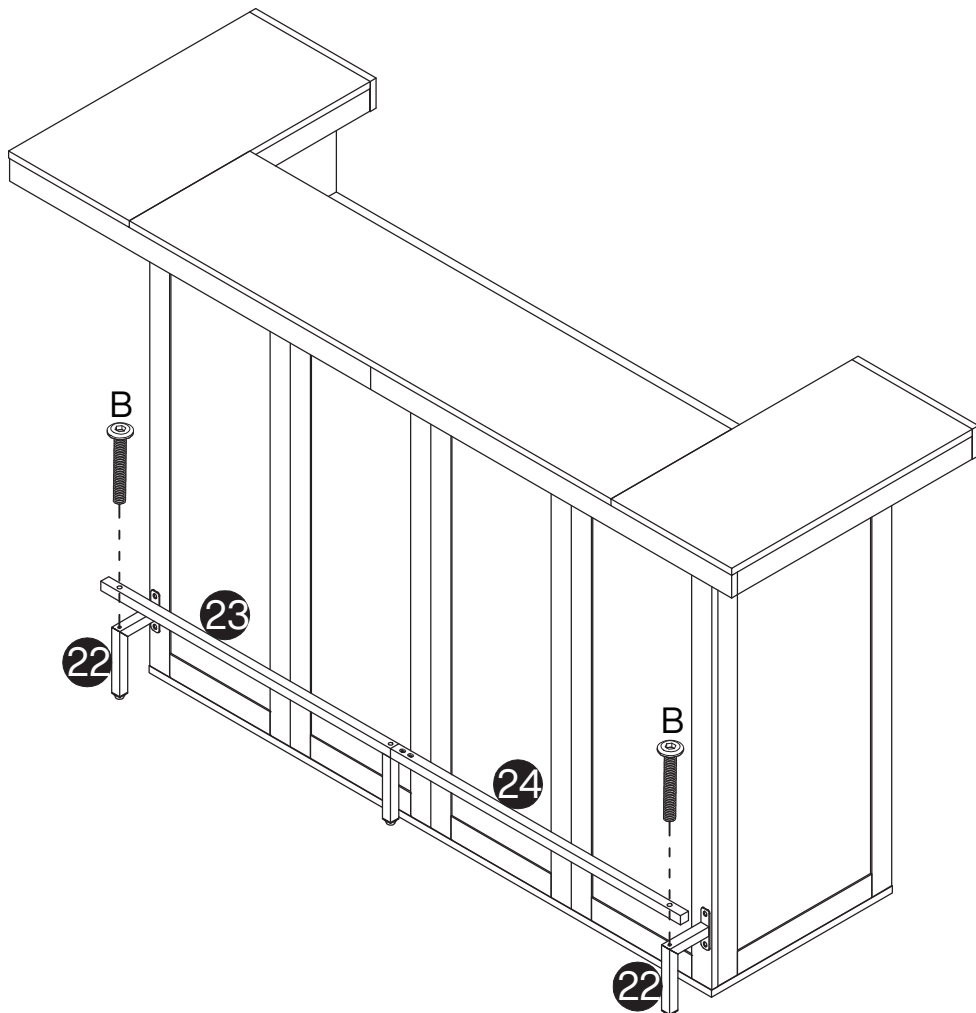

A	B
	
M6X10mm 2 pcs	M6X40mm 1 pc

34



B

M6X40mm 2 pcs

Thank you for your support!

