

**PLEASE DO NOT RETURN TO STORE**

User Manual  
ASSEMBLY INSTRUCTION  
SG-S01  
94.48L\*15.74W\*78.74H Inch







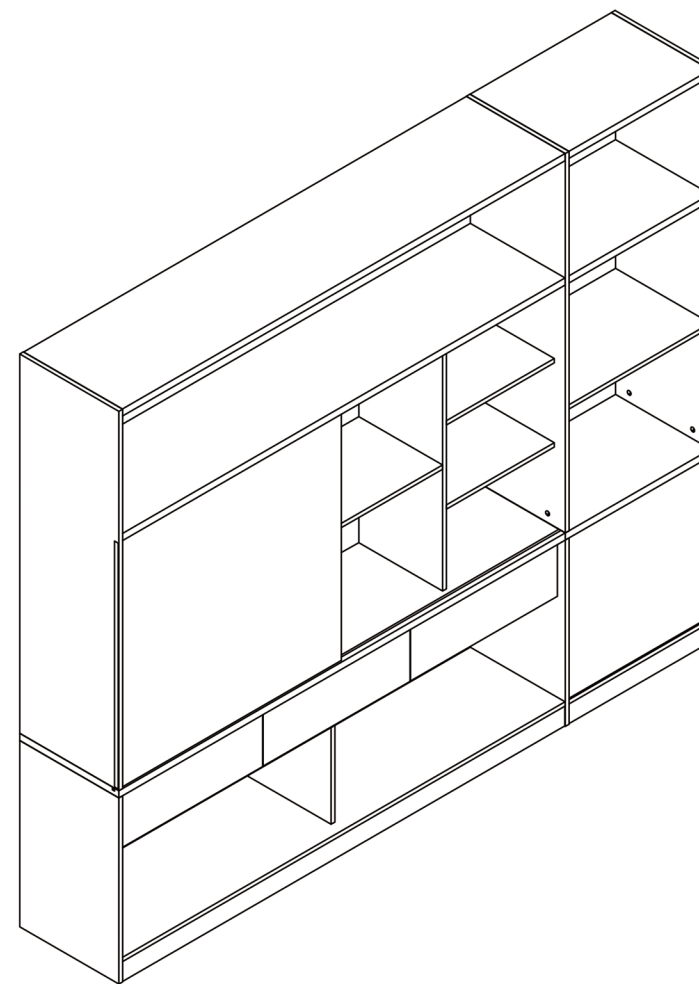





































Please do not return this product to the retailer!  
We are able to assist you in ANY way!

If you find that you have any trouble with assembly or  
missing or damaged parts please contact the seller.











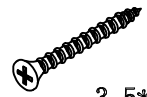

## Parts List

NO.	Drawing	Dimension	QTY
1		1785*398*25mm	*1
2		570*398*25mm	*1
3		1325*400*15mm	*1
4		1785*398*25mm	*1
5		1325*400*15mm	*1
6		1325*400*15mm	*1
7		570*382*25mm	*1
8		865*338*15mm	*1
9		865*338*15mm	*1
10		435*338*15mm	*3
11		570*382*15mm	*1
12		1800*400*25mm	*1
13		600*400*25mm	*1
14		650*400*15mm	*1
15		1785*338*15mm	*1
16		185*338*15mm	*2
17		650*400*15mm	*1
18		650*400*15mm	*1
19		1785*398*15mm	*1
20		570*398*15mm	*1
21		568*362*15mm	*1

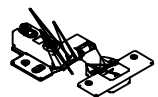
NO.	Drawing	Dimension	QTY
22		1785*70*15mm	*2
23		366*70*15mm	*1
24		570*70*15mm	*2
25		1785*410*15mm	*1
26		1785*865*15mm	*1
27		1785*565*15mm	*1
28		1310*570*15mm	*1
29		570*565*15mm	*1
30		561*566*15mm	*1
31		859*900*15mm	*1
32		592*208*15mm	*1
33		592*208*15mm	*1
34		592*208*15mm	*1
35		300*140*15mm	*3
36		300*140*15mm	*3
37		532*140*15mm	*2
38		526*140*15mm	*1
39		542*294*4mm	*2
40		536*294*4mm	*1
41		284*140*15mm	*3
41		365*338*15mm	*1

## Hardware Fitting

NO.	Drawing	QTY
A		*190
B		*190
C	 8*60mm	*2
D		*3
E	 3.5*35mm	*12
F	 3.5*14mm	*55
G		*2

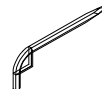
NO.	Drawing	QTY
H		*1
I		*2
J		*2
K		*4
L	 4mm	*1

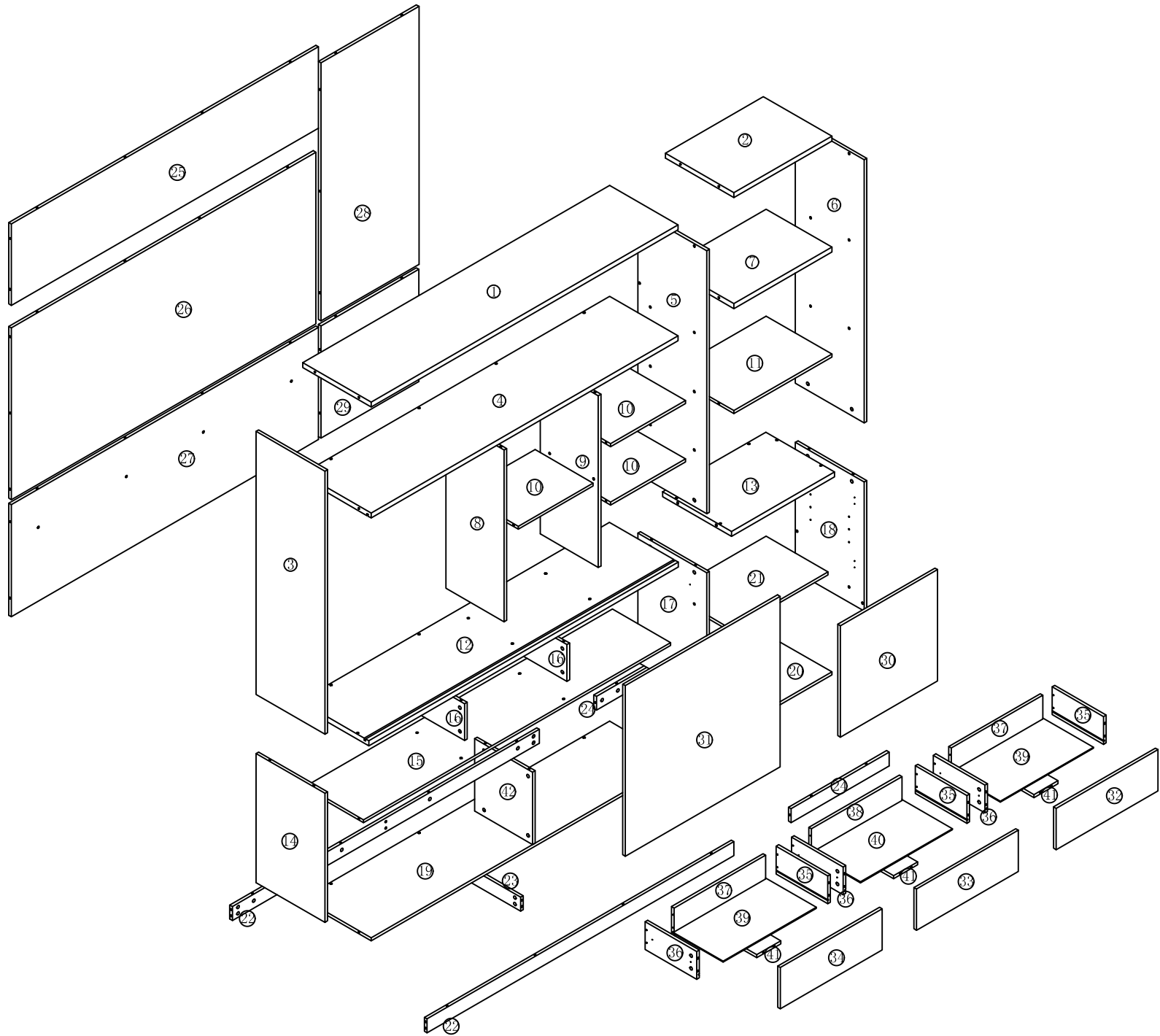

## Cam Coupling Using Methods

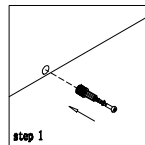

**Step1.**  
Connect the cam coupling A as directed in the assembly instructions using hand.

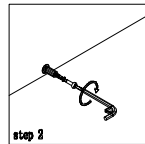

**Step2.**  
Screw the cam coupling A as directed in the assembly instructions.

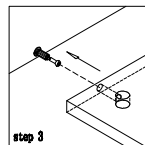

**Step3.**  
Push the cam coupling A into the entry hole.

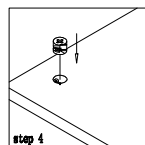

**Step4.**  
Insert the cam coupling B as shown in the instructions.

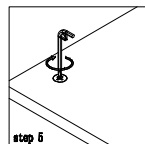

**Step5.**  
Turn the cam coupling B clockwise with a screwdriver

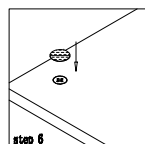

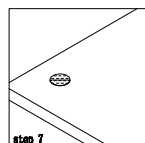

**Step6.**  
Put on Beautycam.



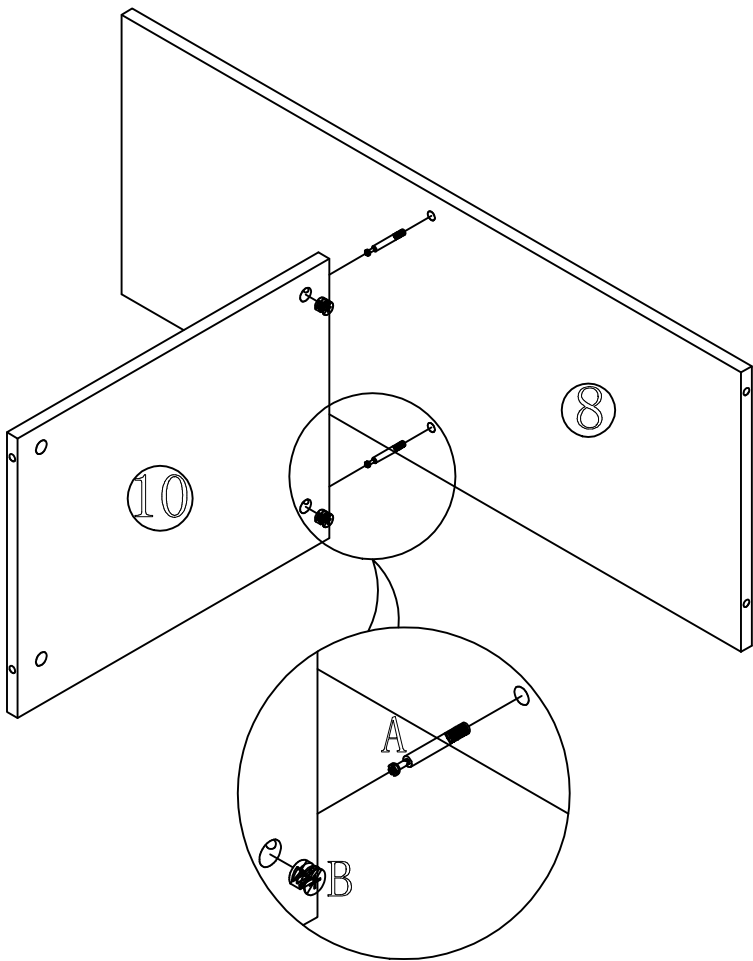

**Step7.**  
Finished.

You should feel a click when the camlock is locked in place.  
The joint is now secure.

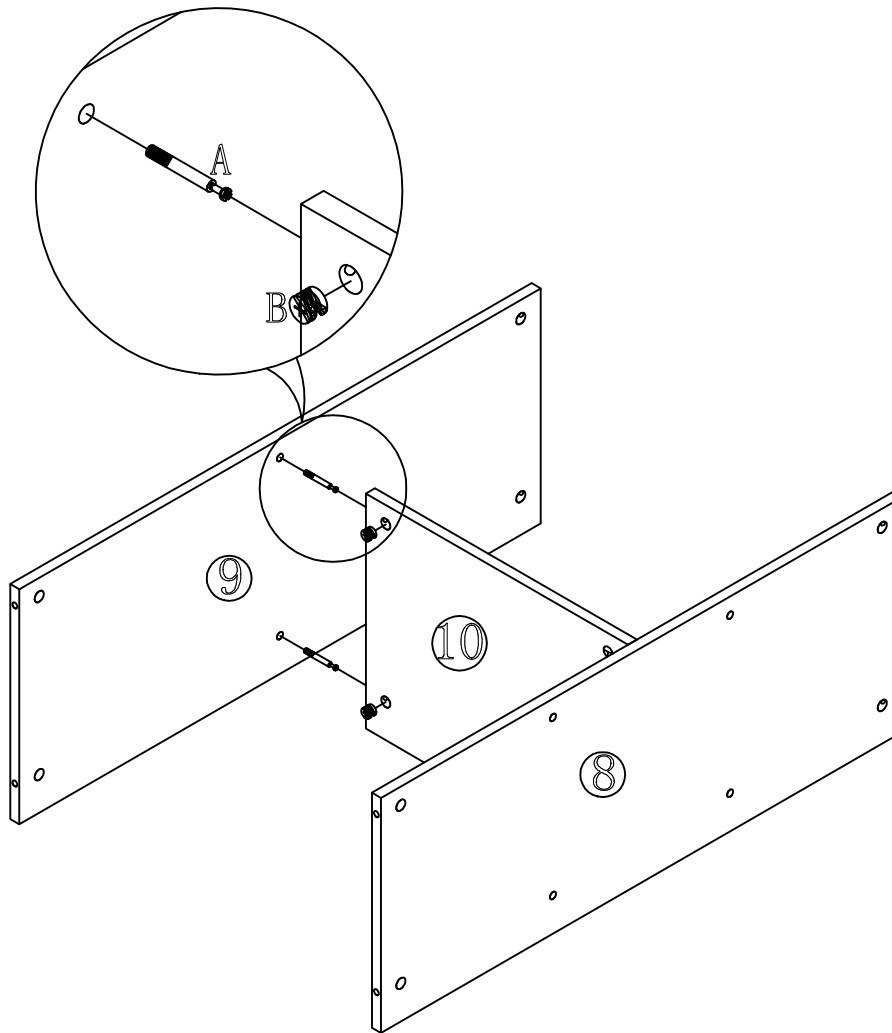

A		*2
B		*2



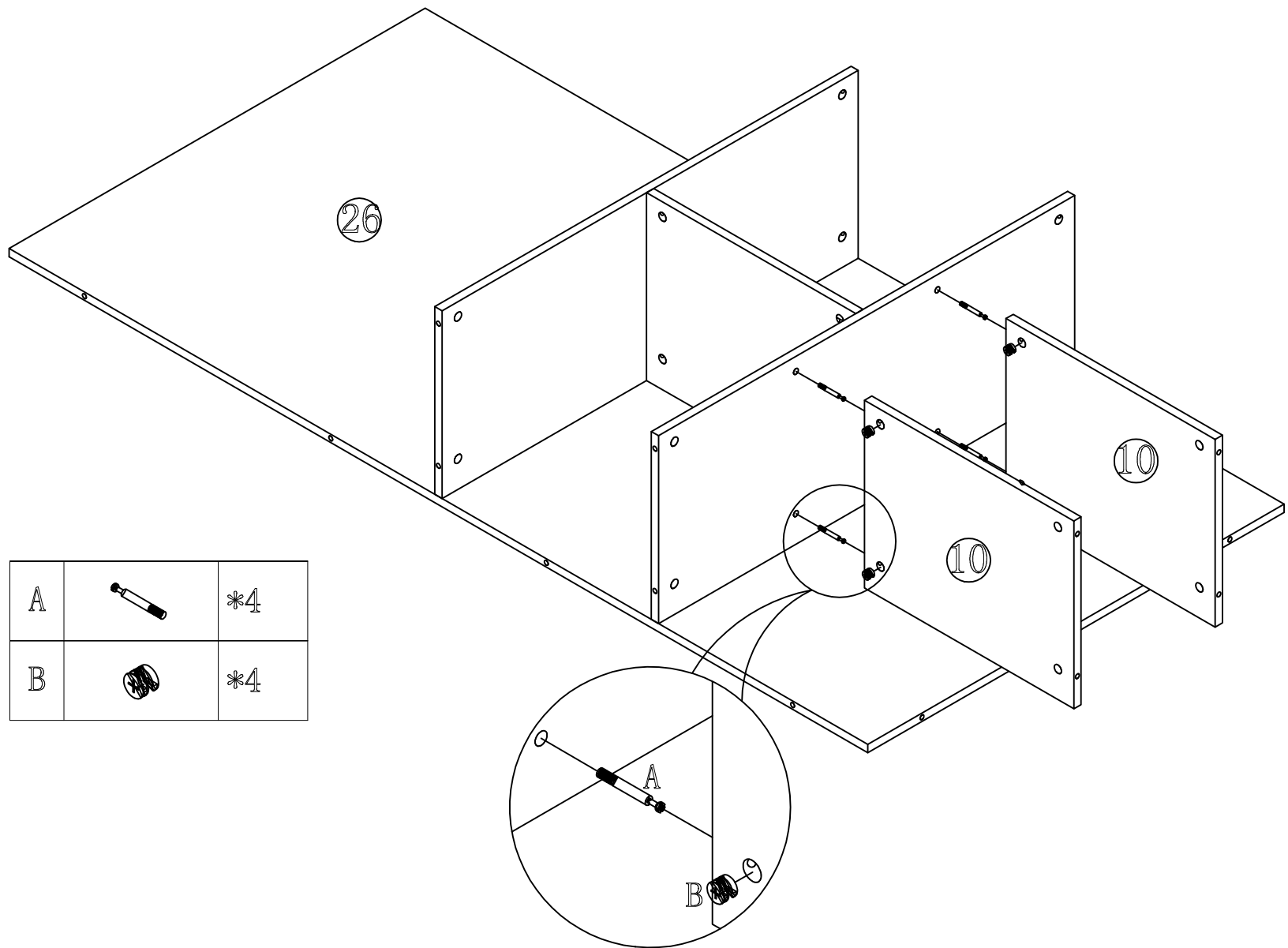

A		*2
B		*2

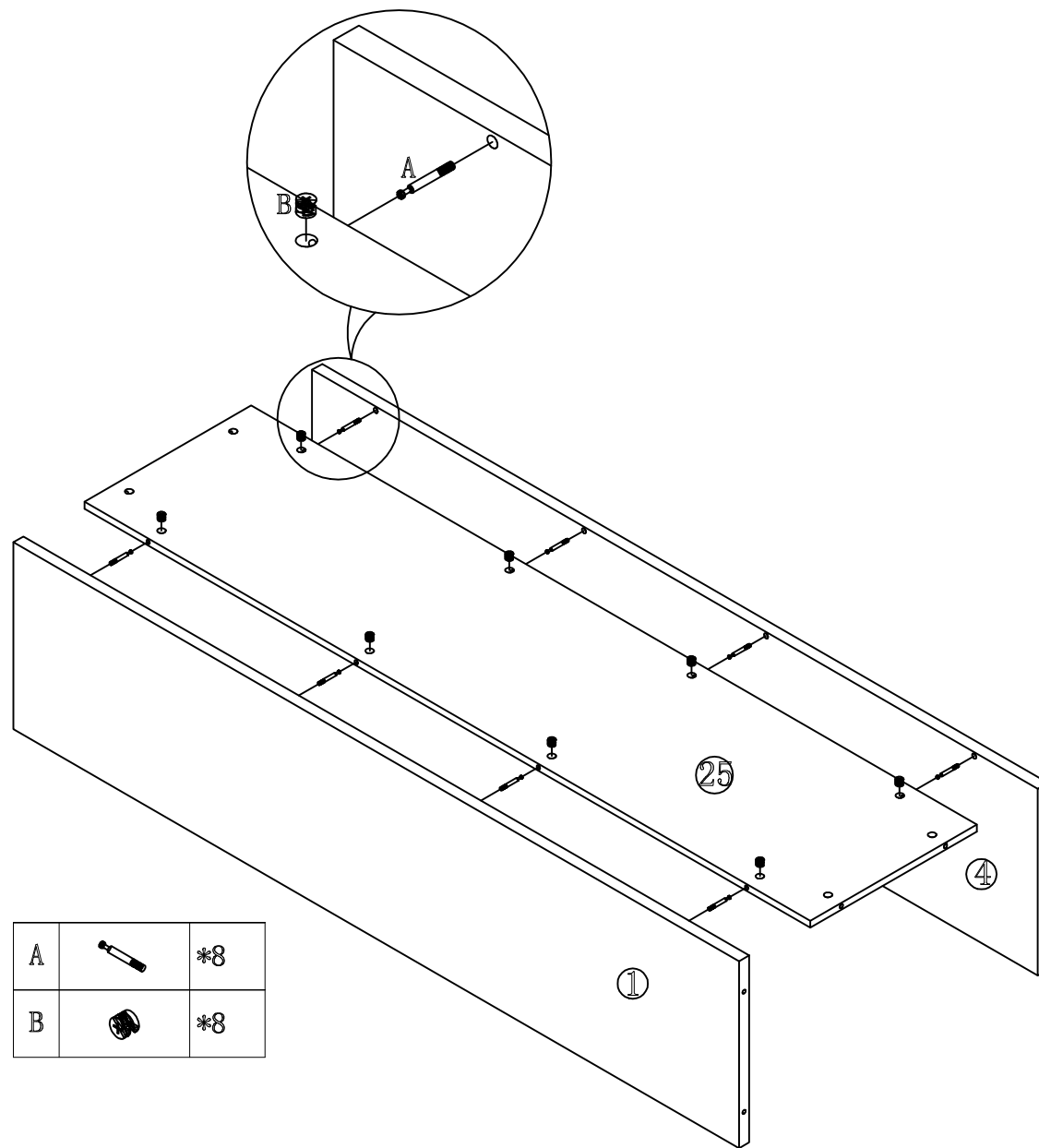

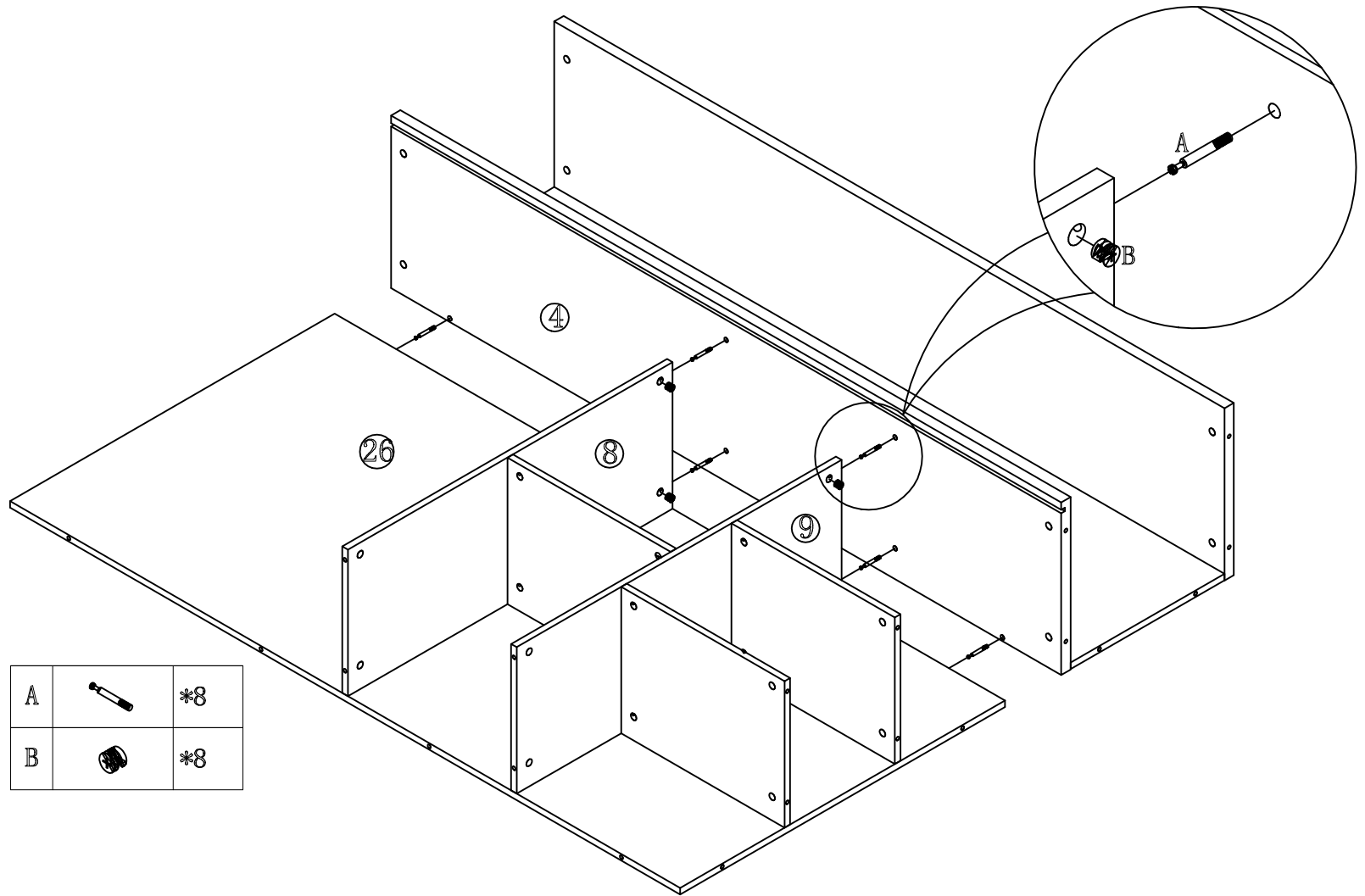

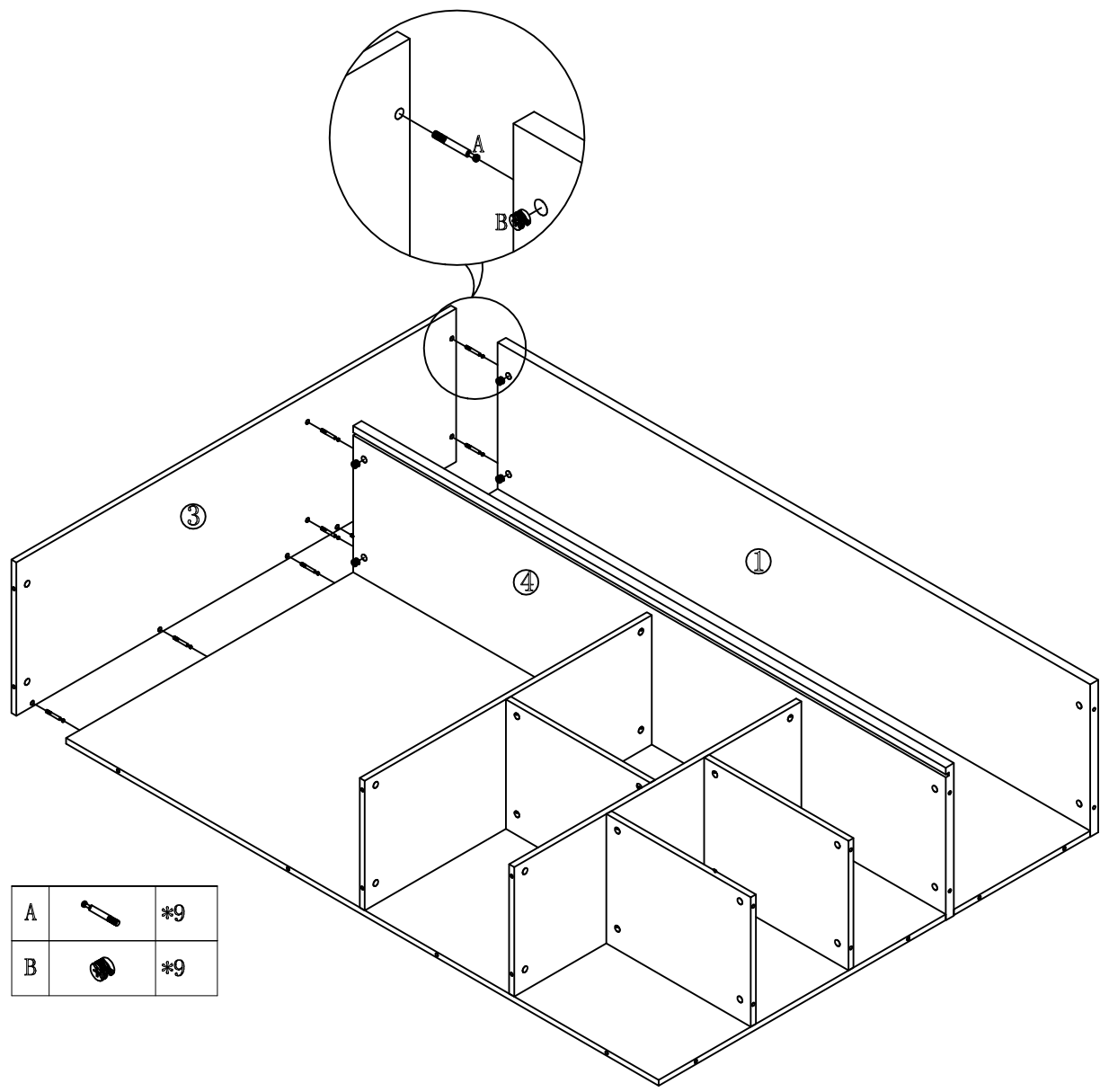



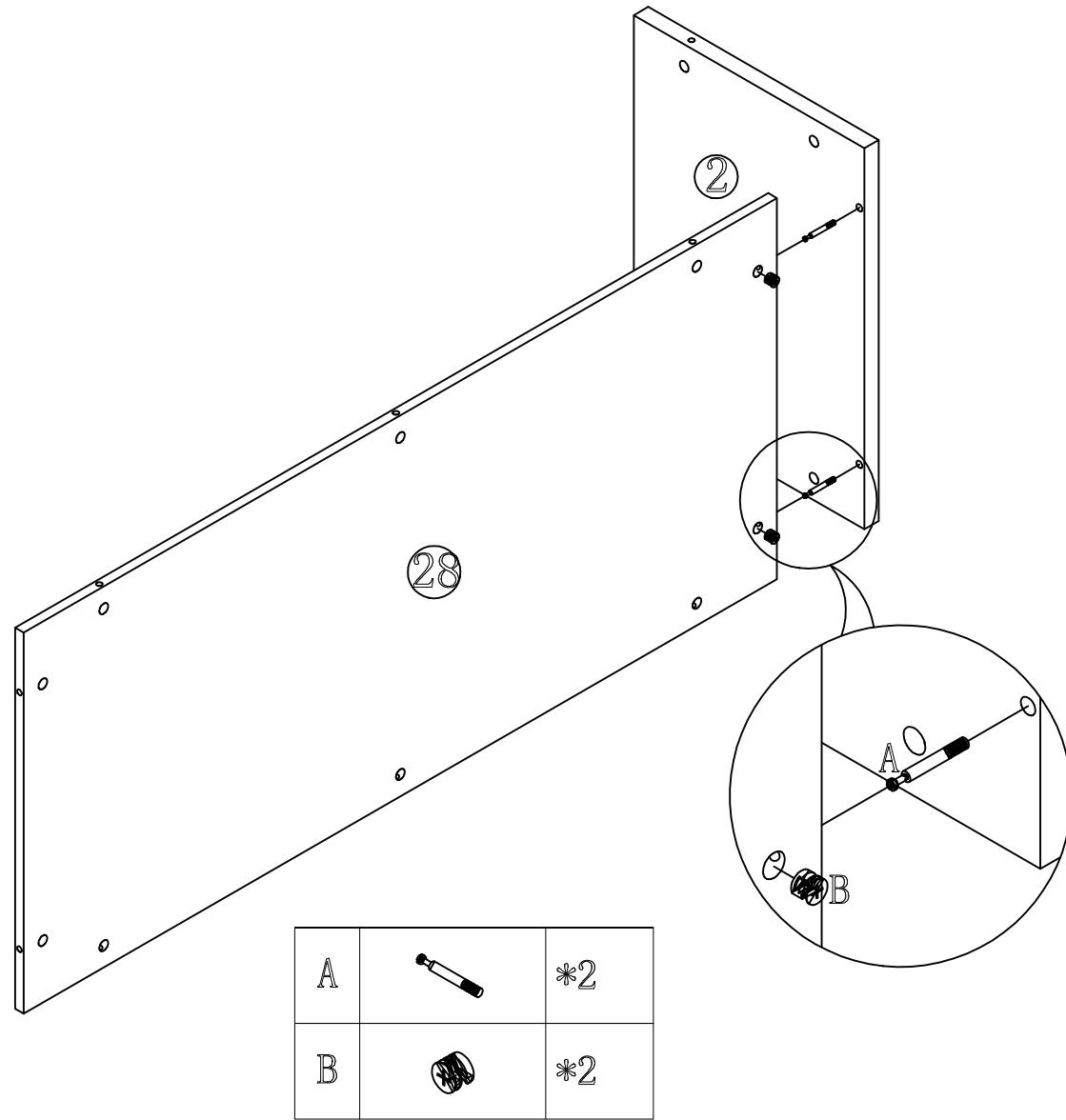

A		*9
B		*9

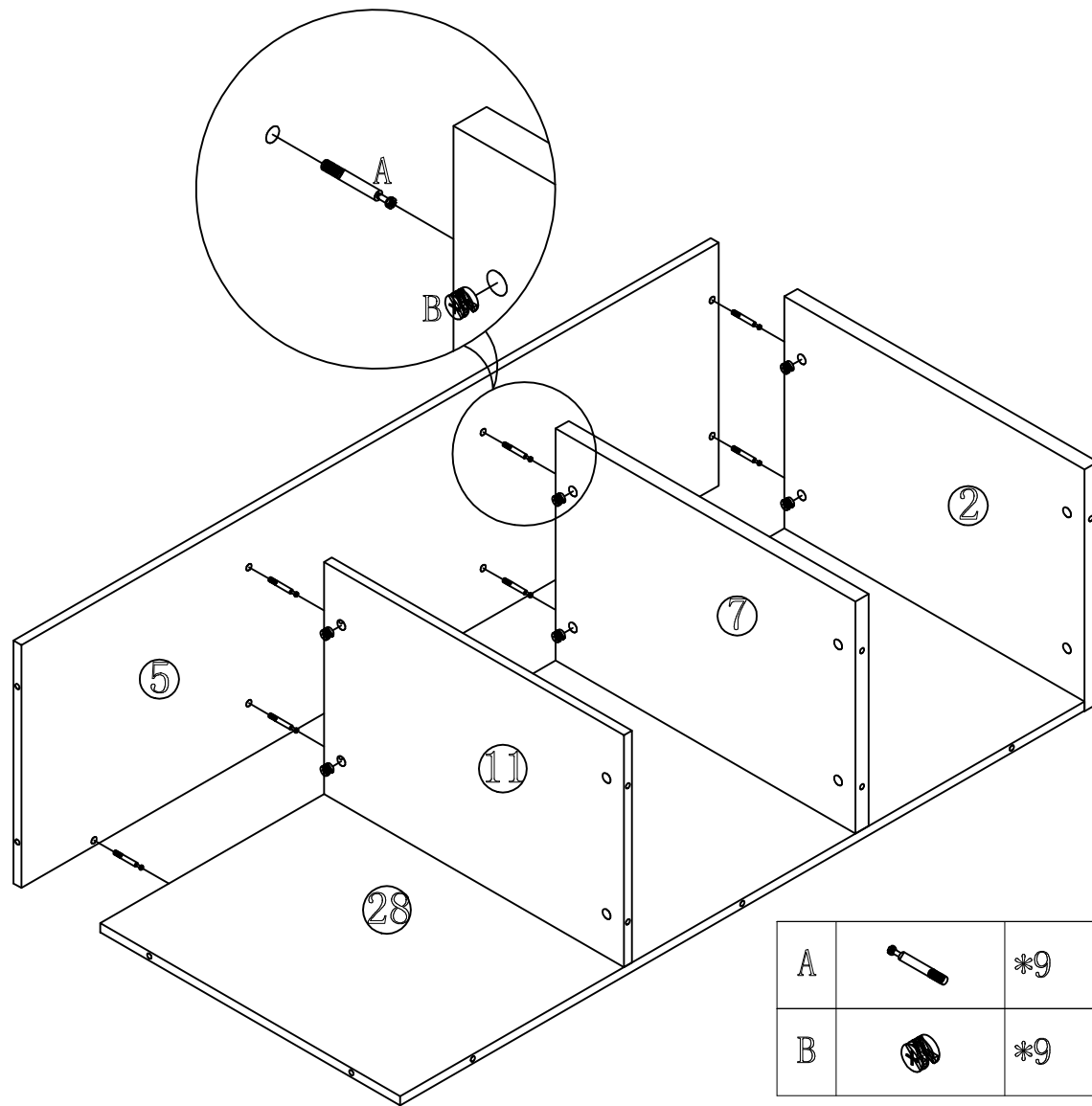

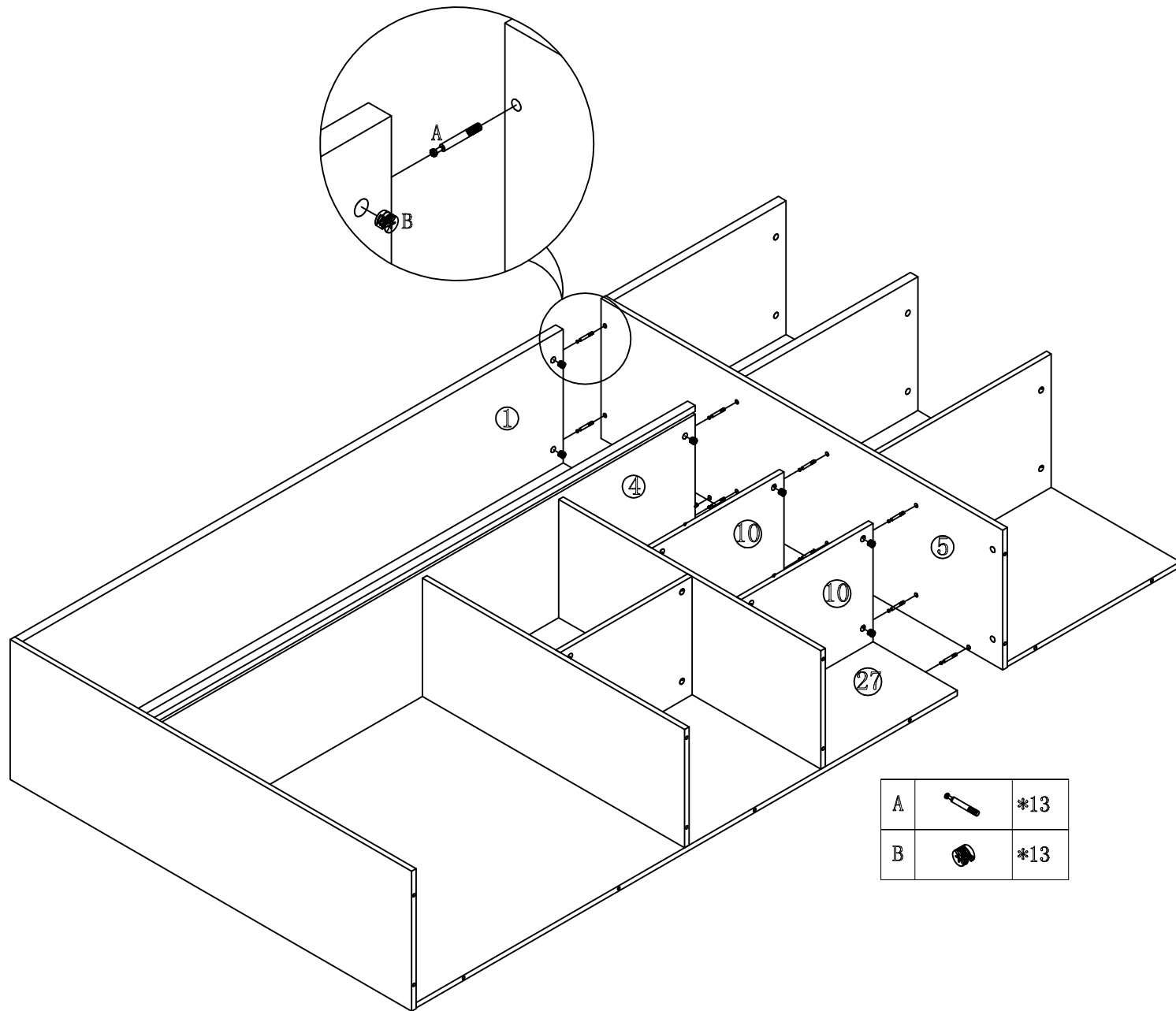



A		*13
B		*13

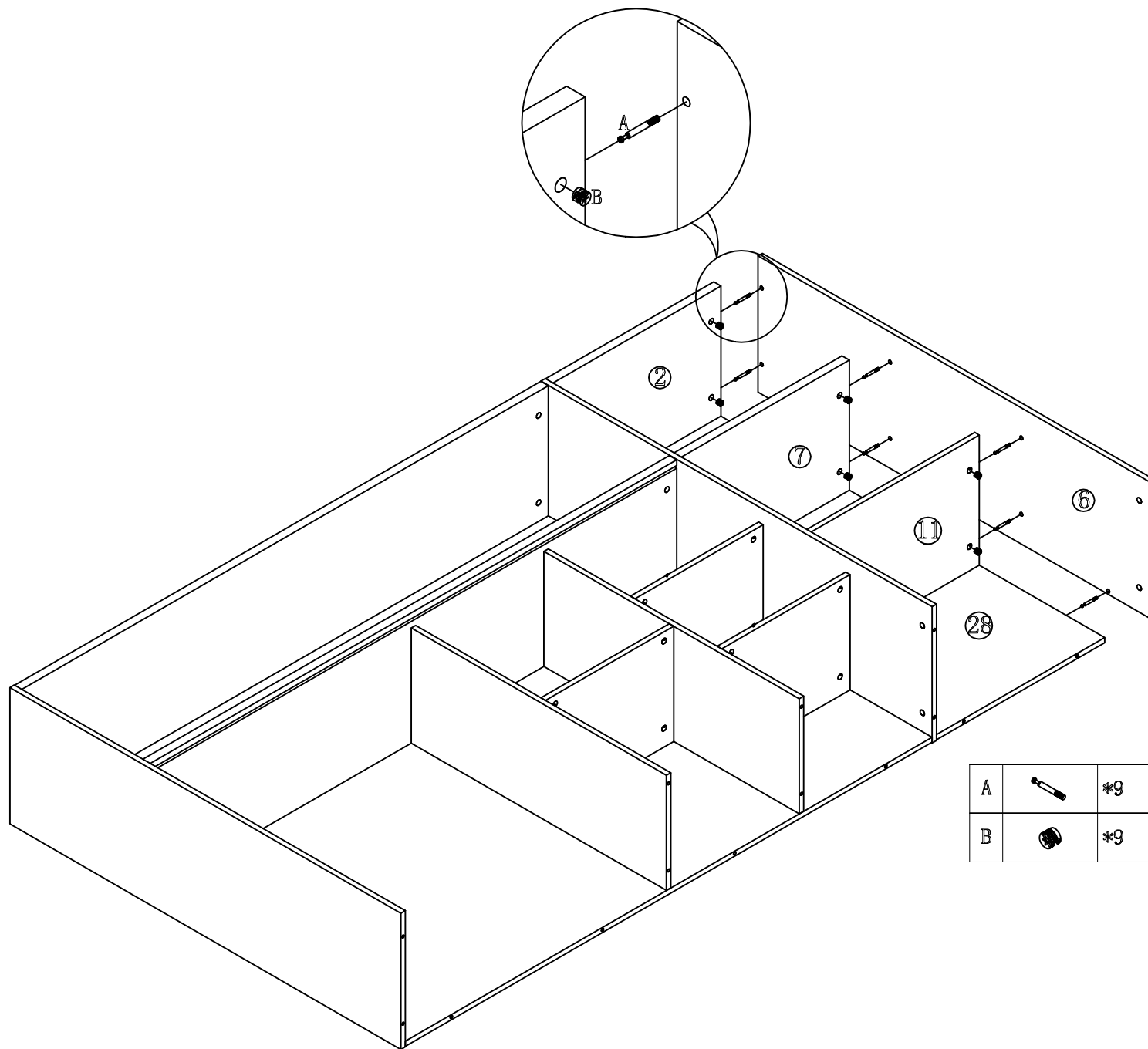

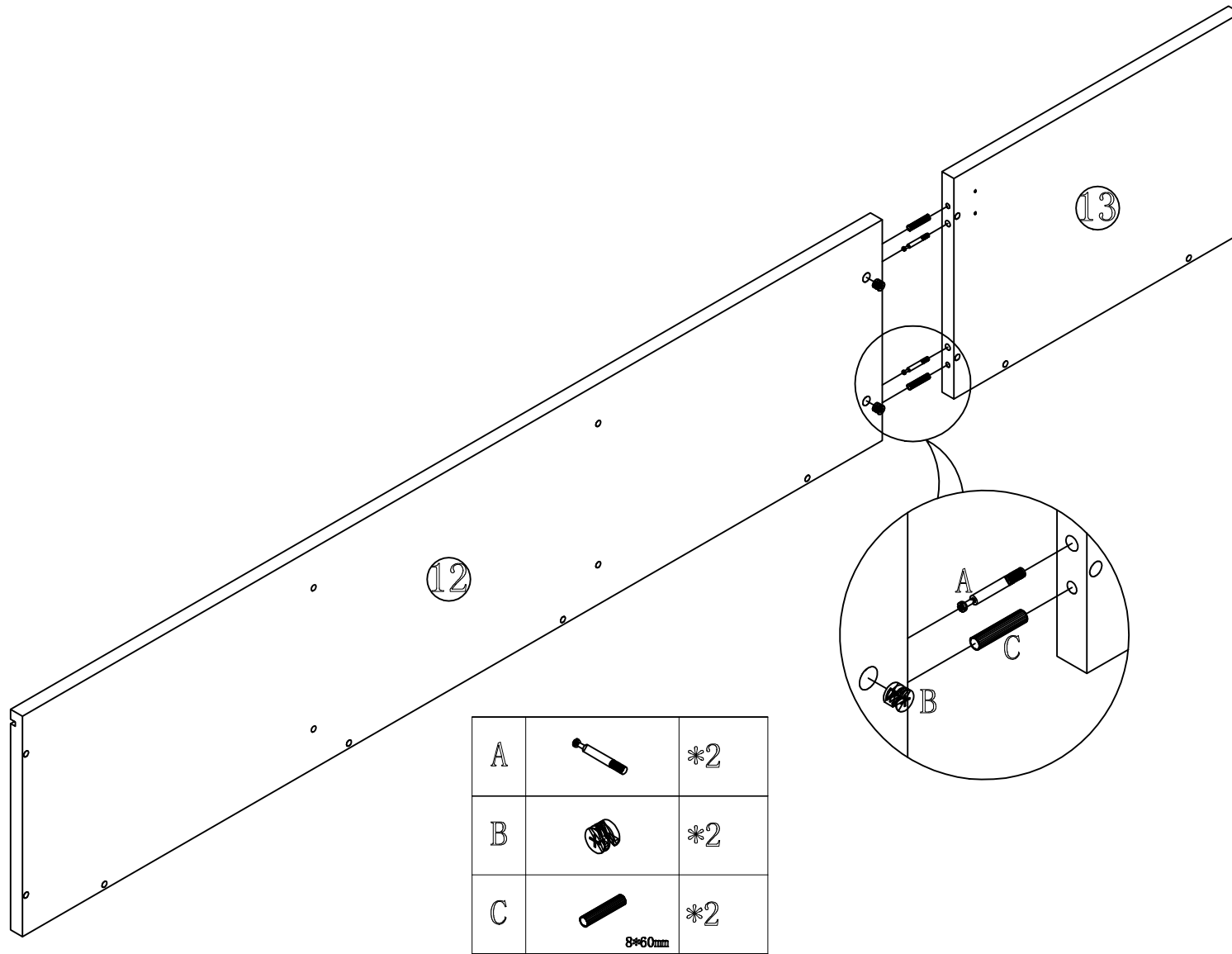

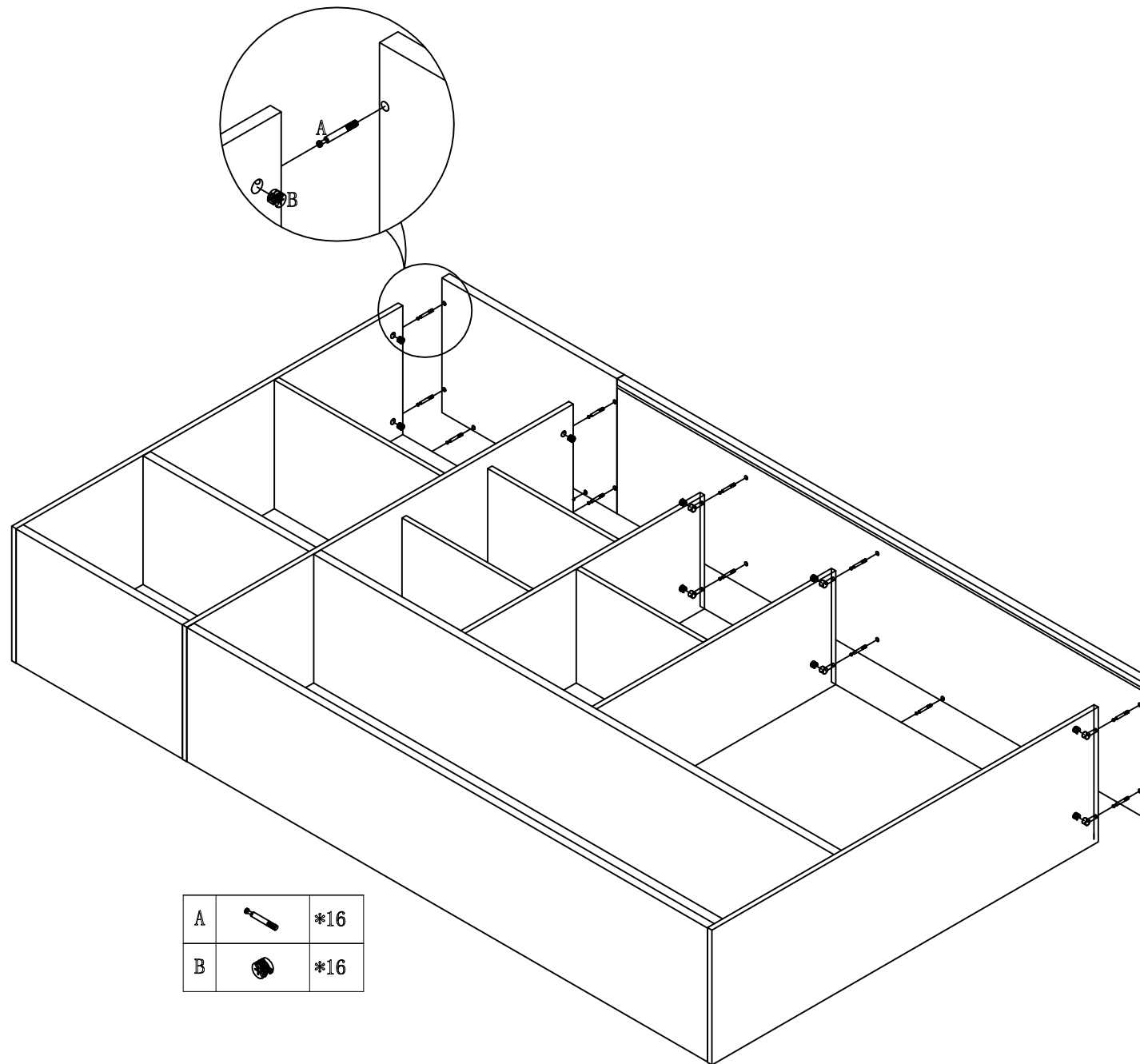

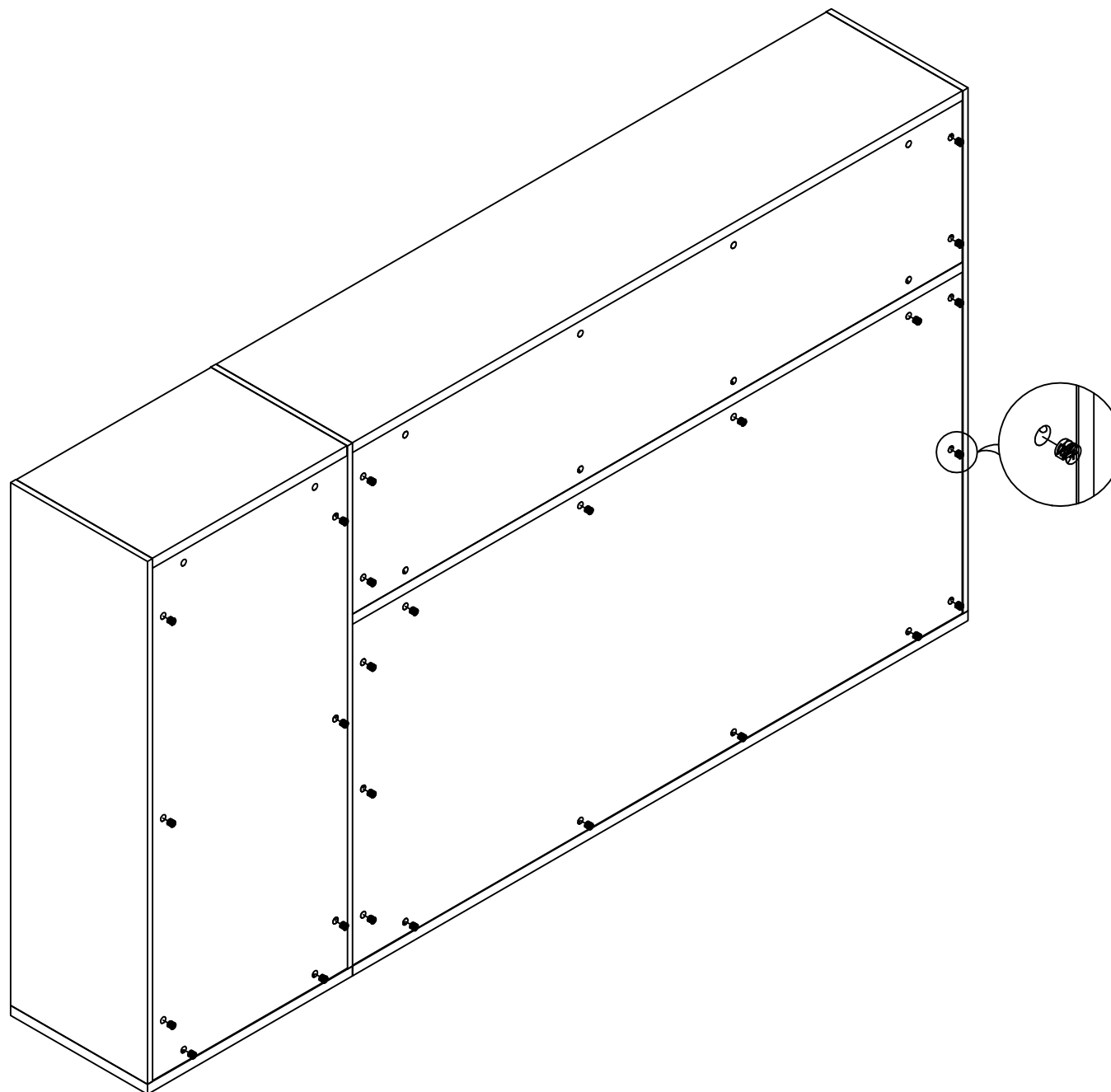

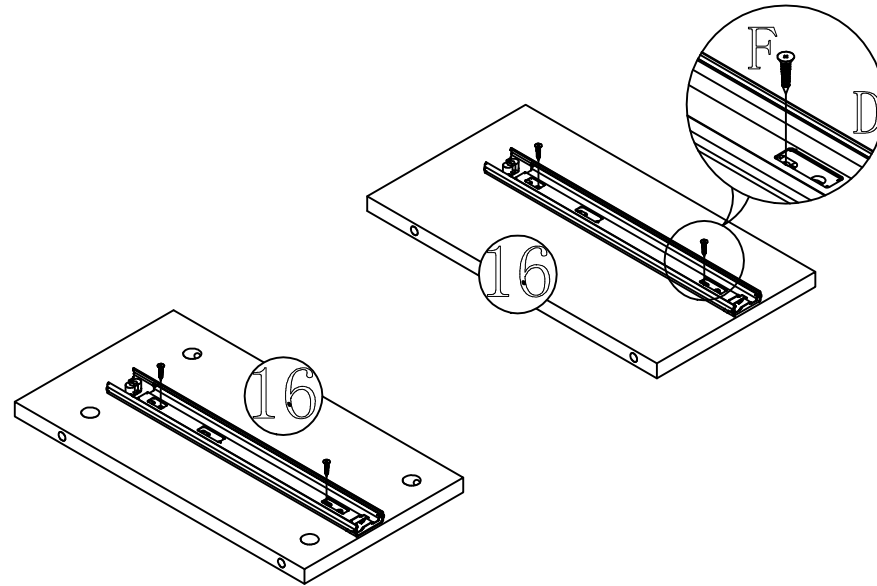



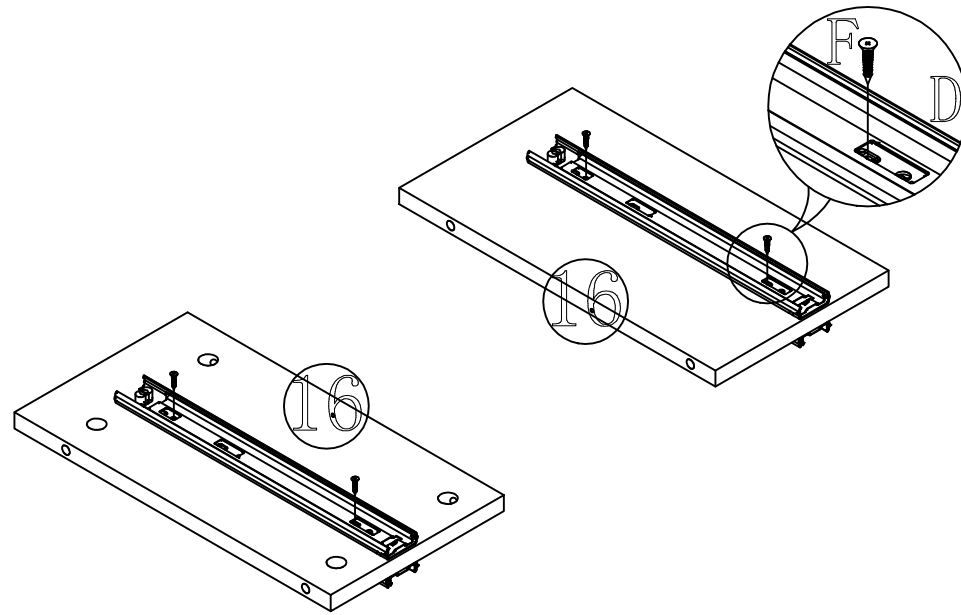

D		*1
F	 3.5*14mm	*4



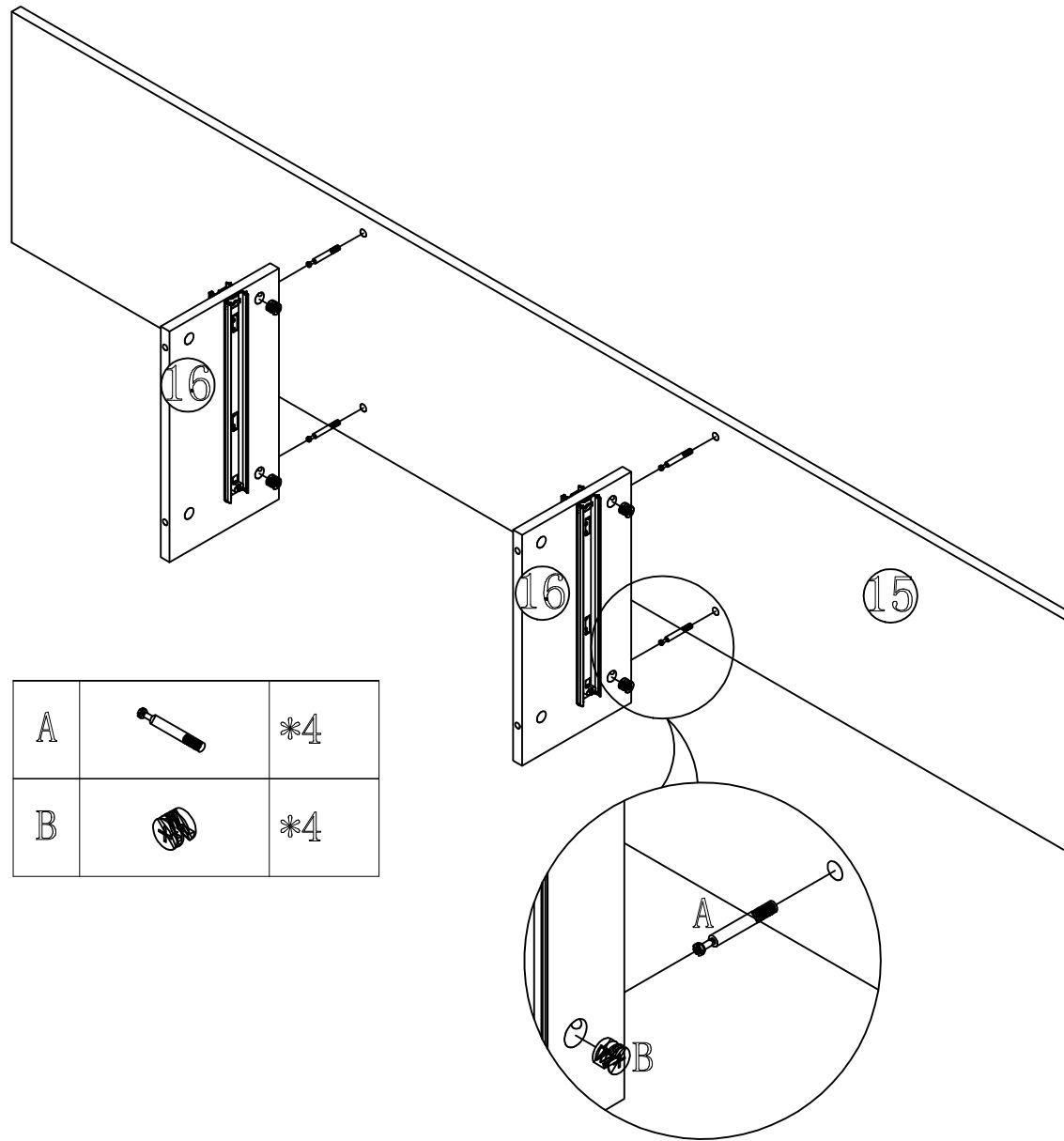

D		*1
F	 3.5*14mm	*4

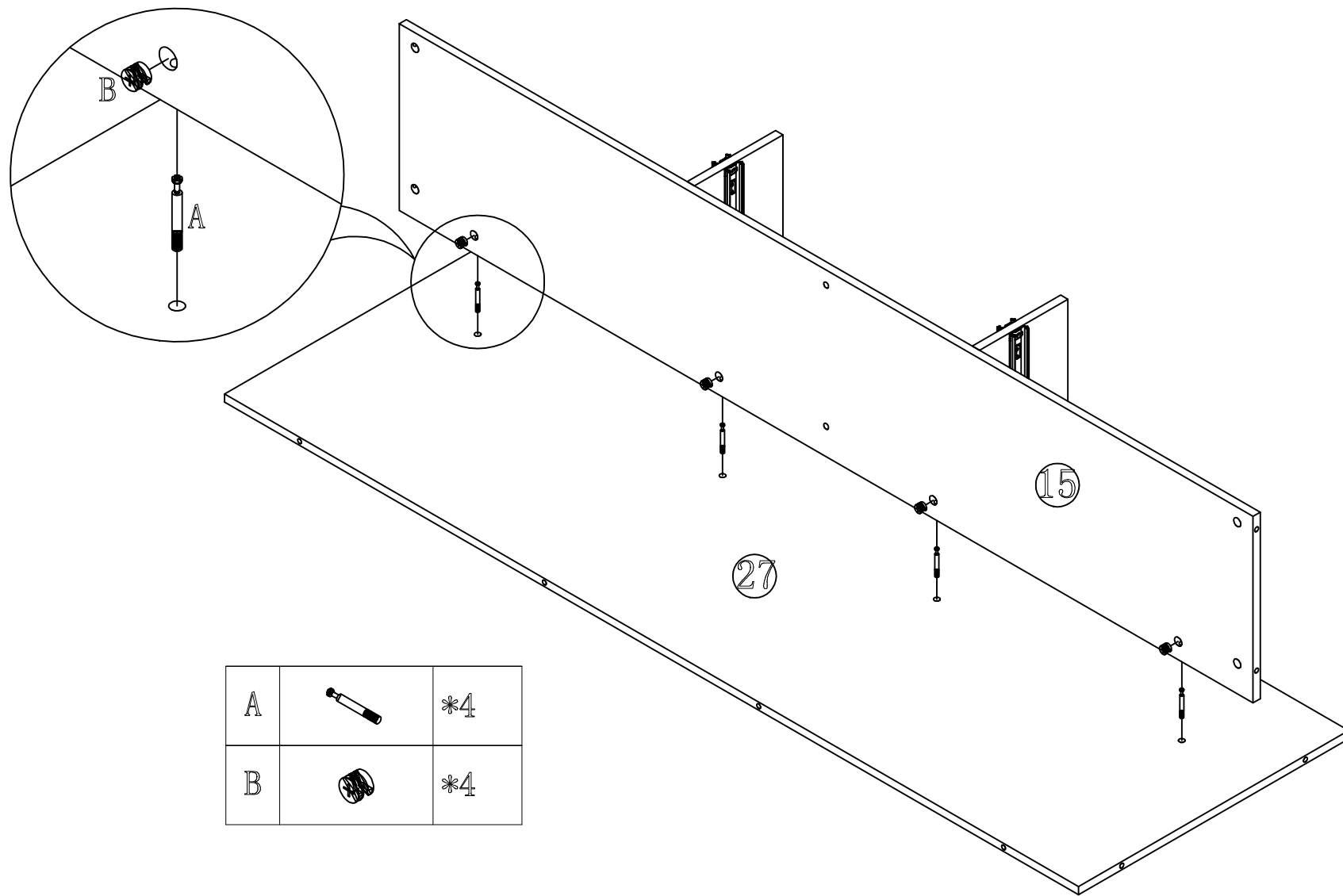

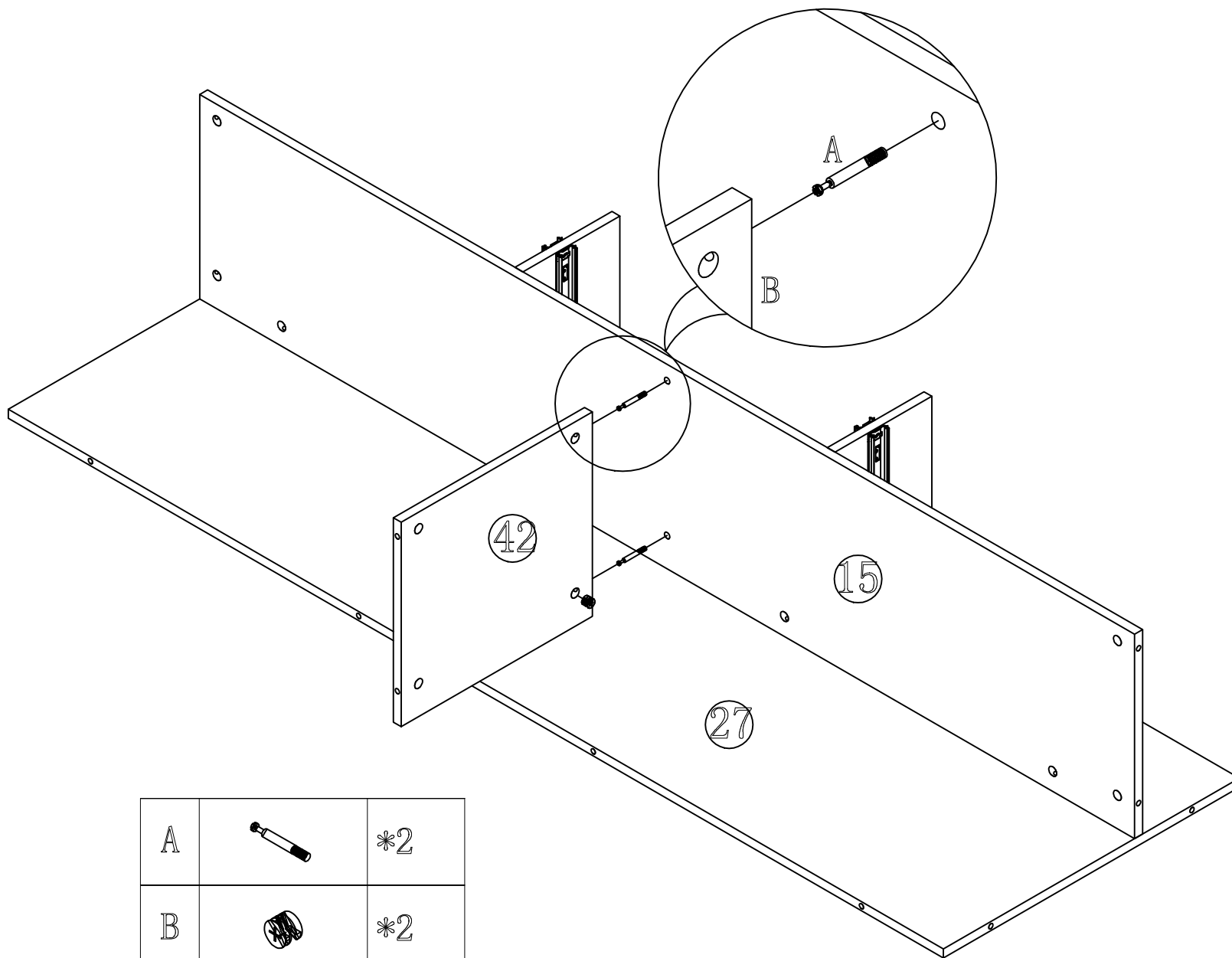



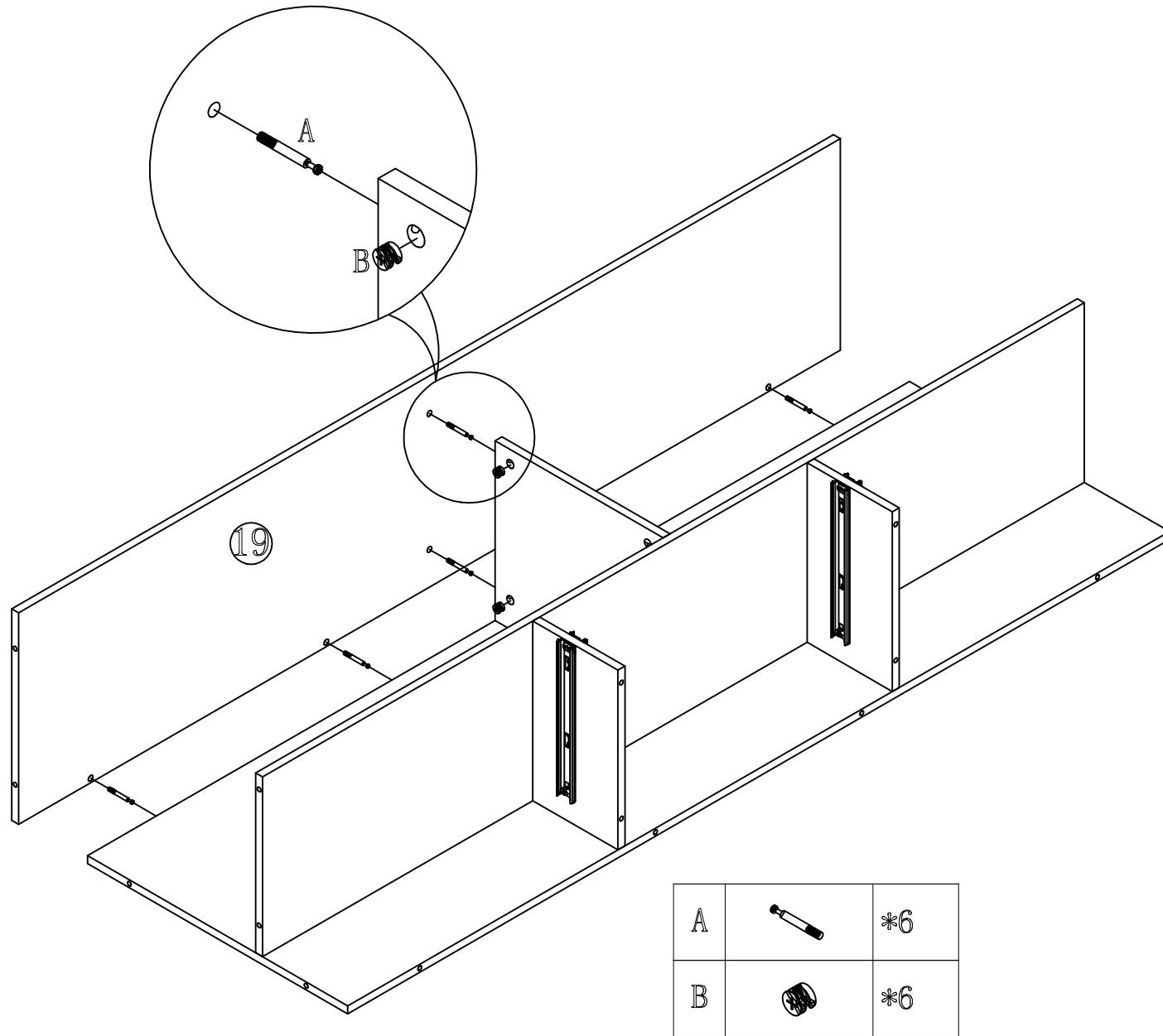

A		*2
B		*2

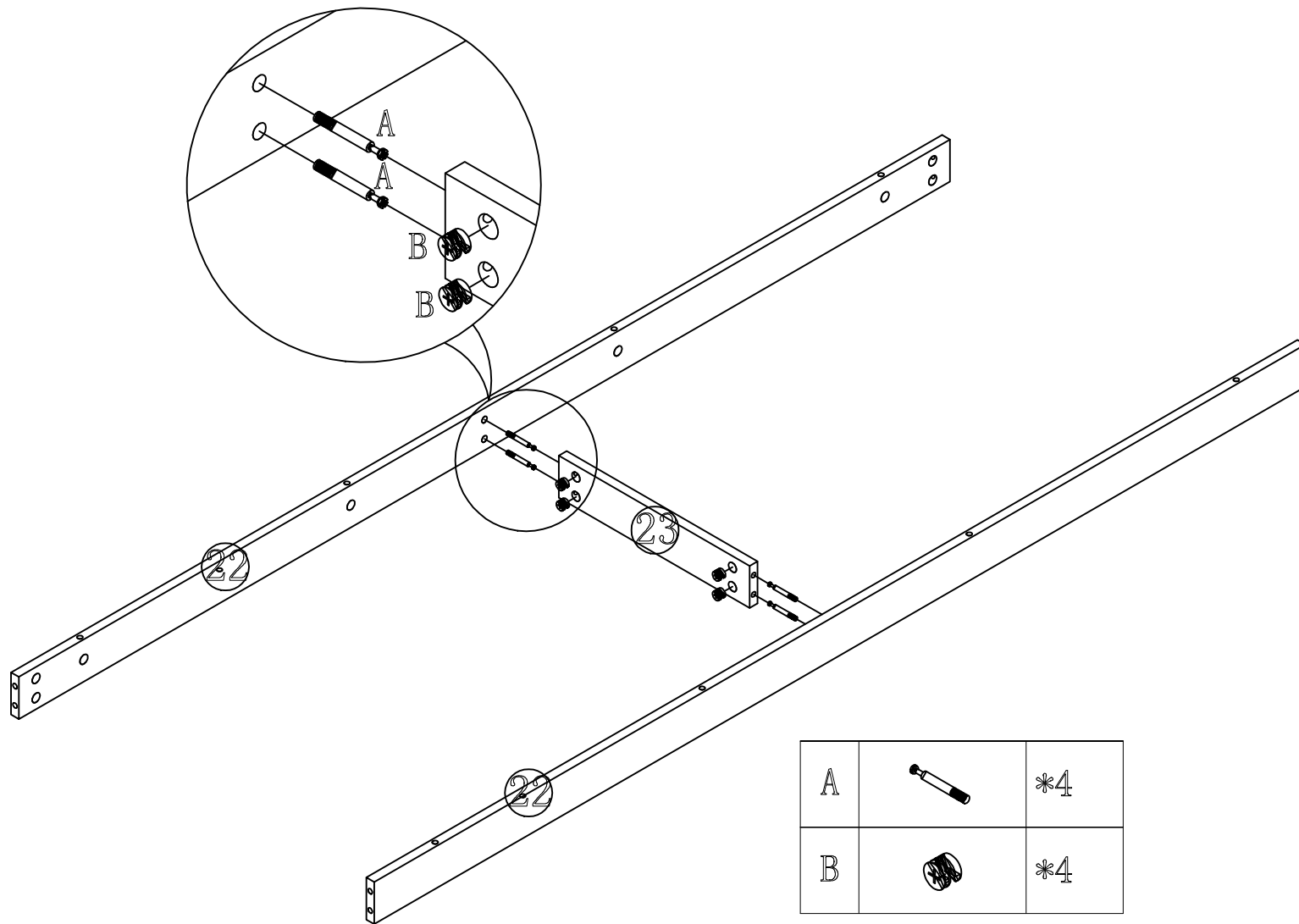

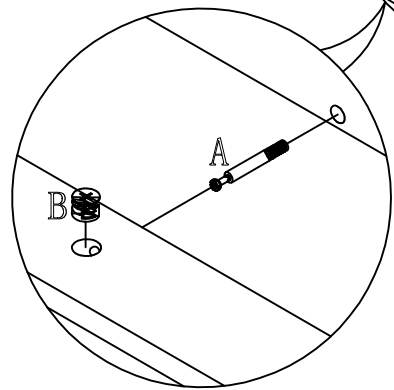
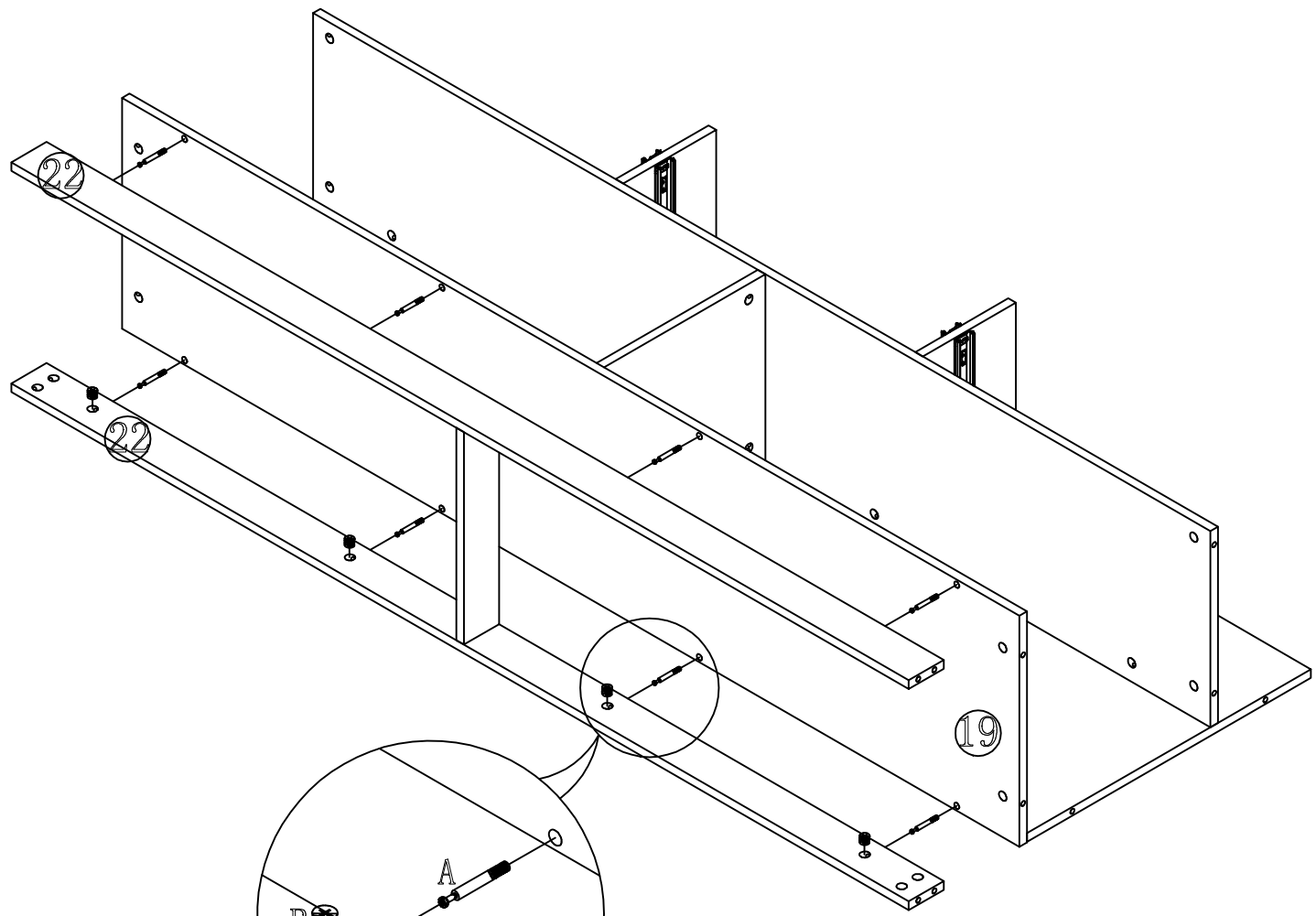





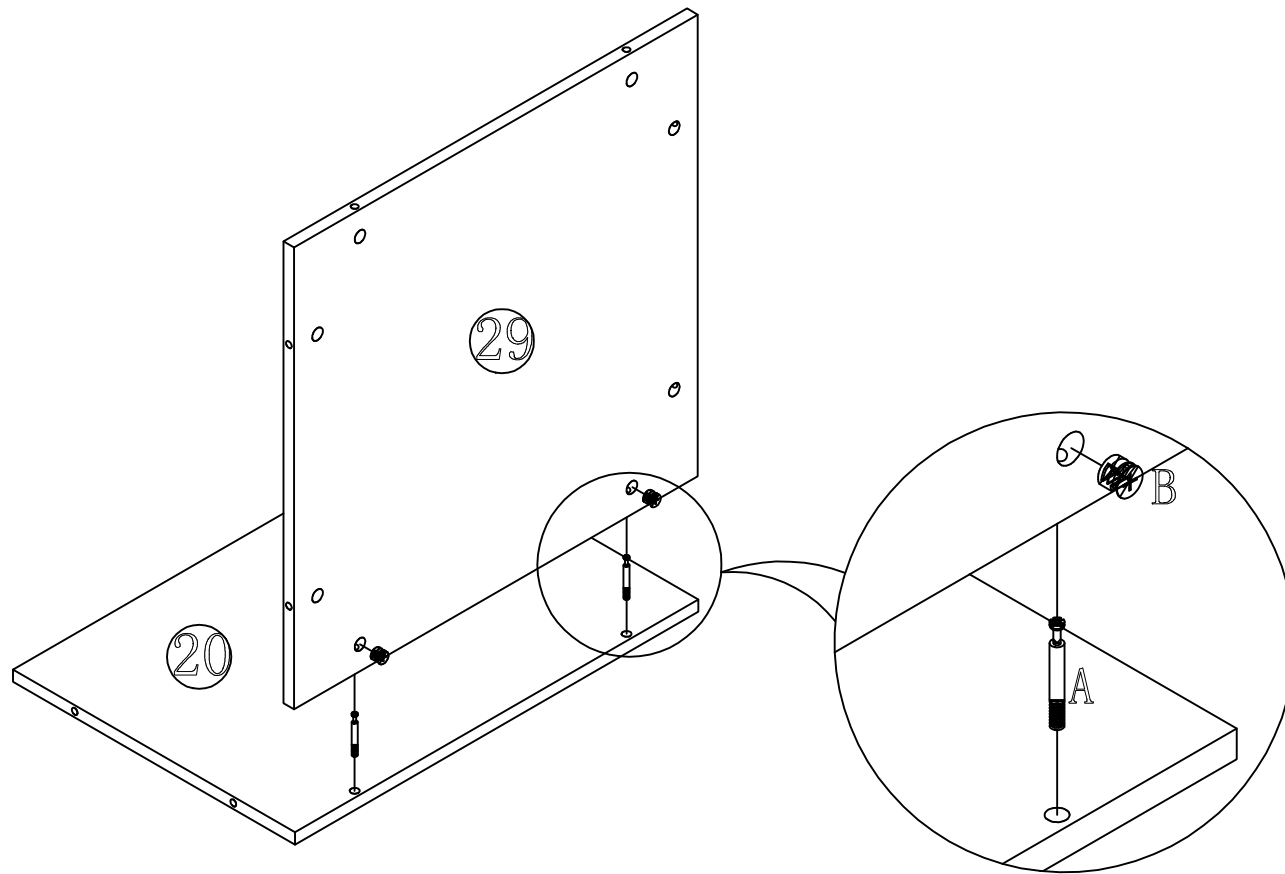

A		*8
B		*8



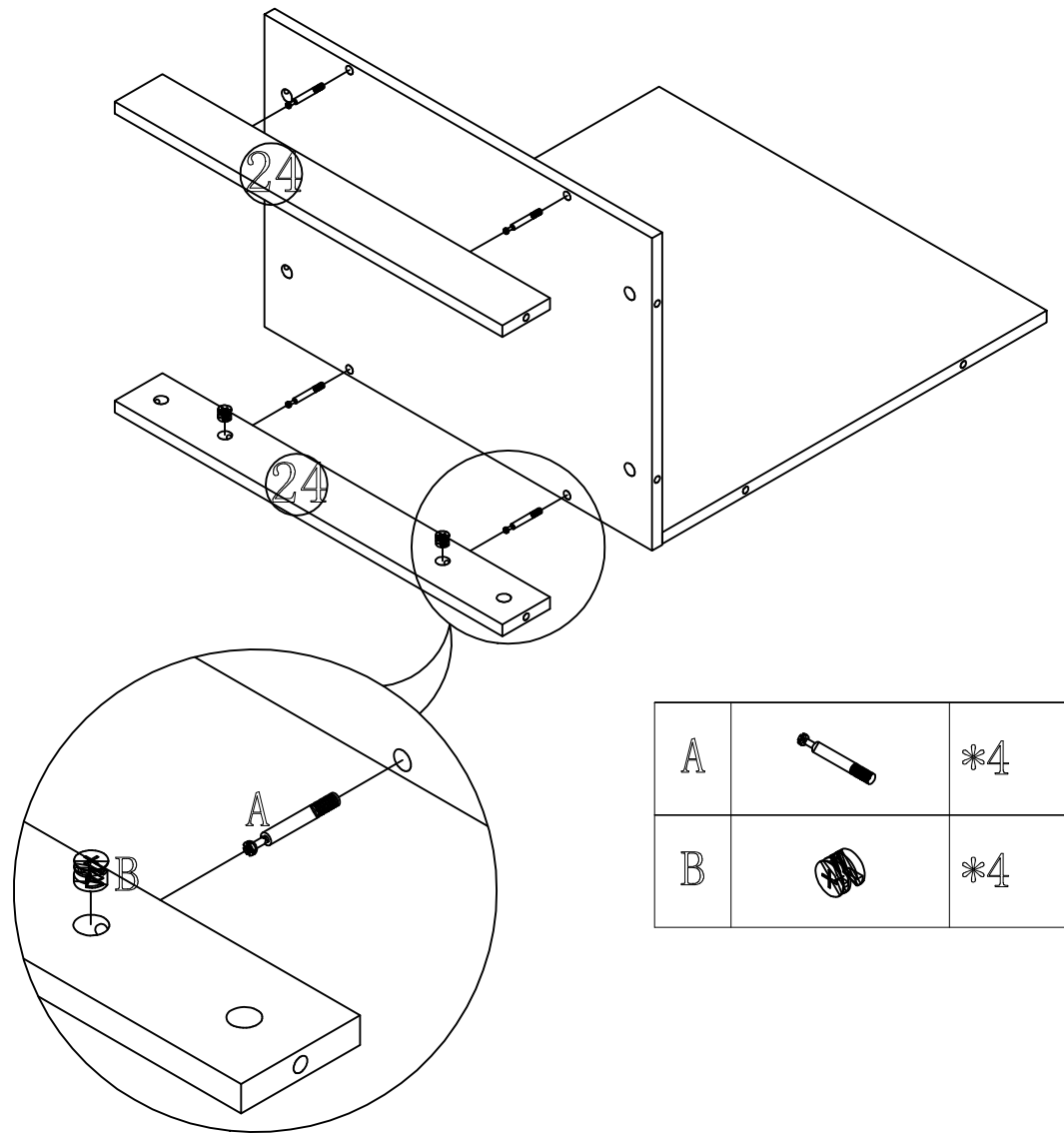

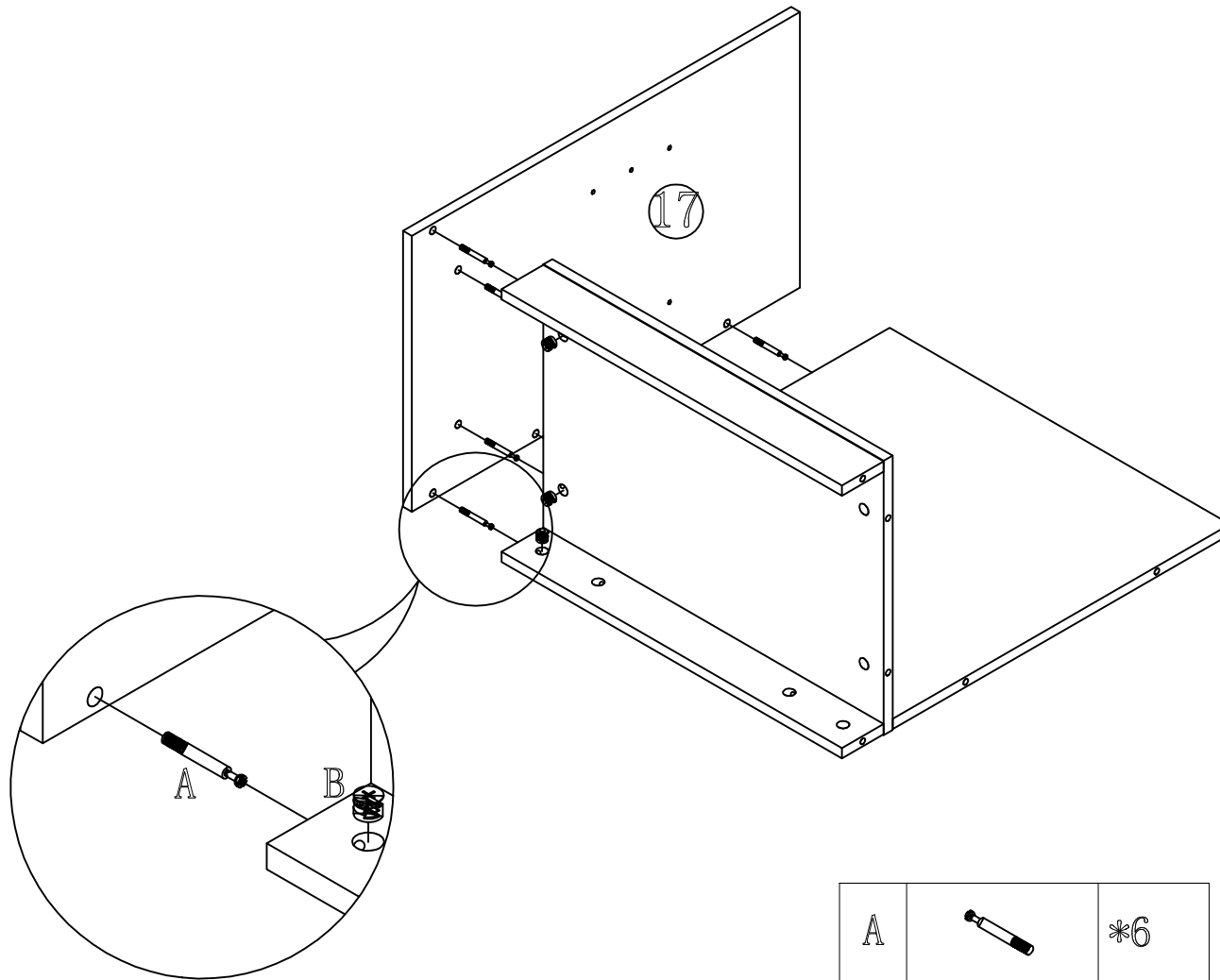
A		*2
B		*2





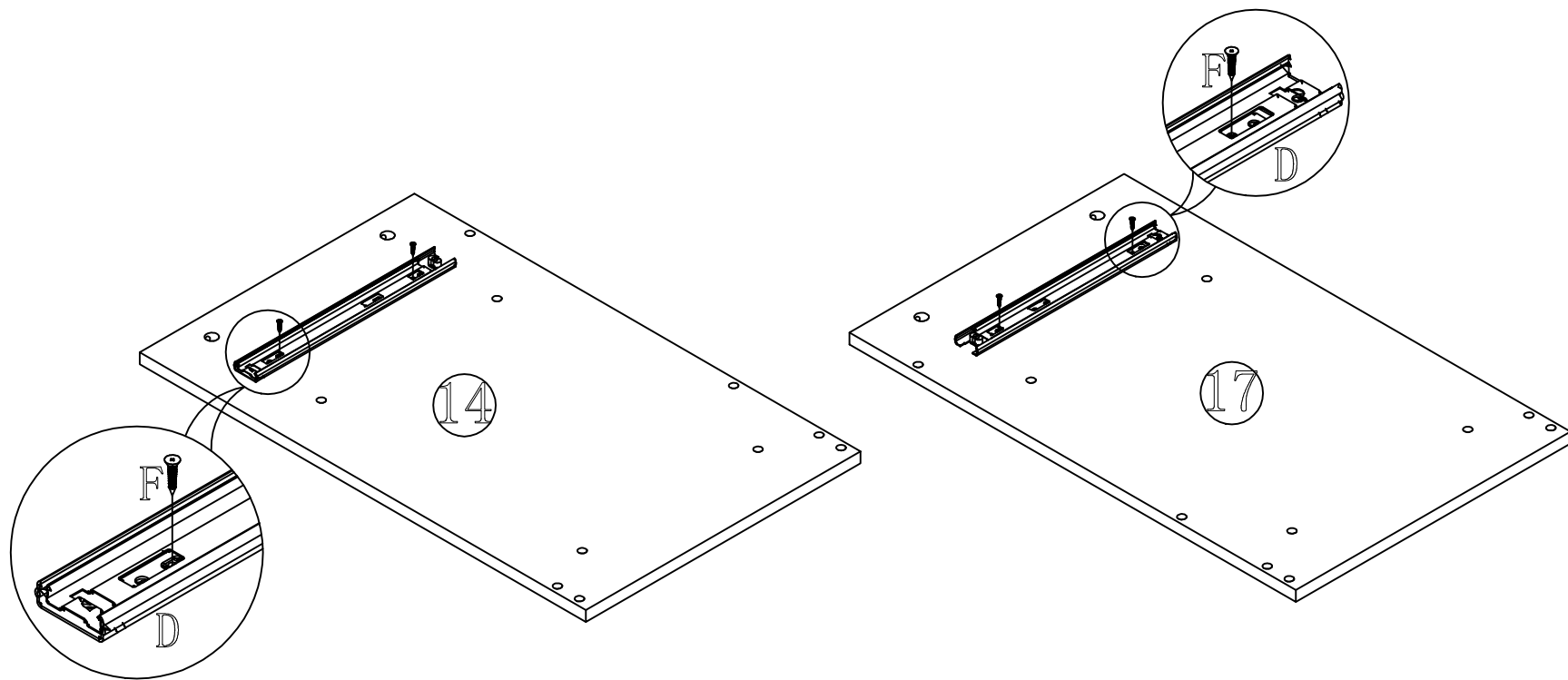

A		*6
B		*6

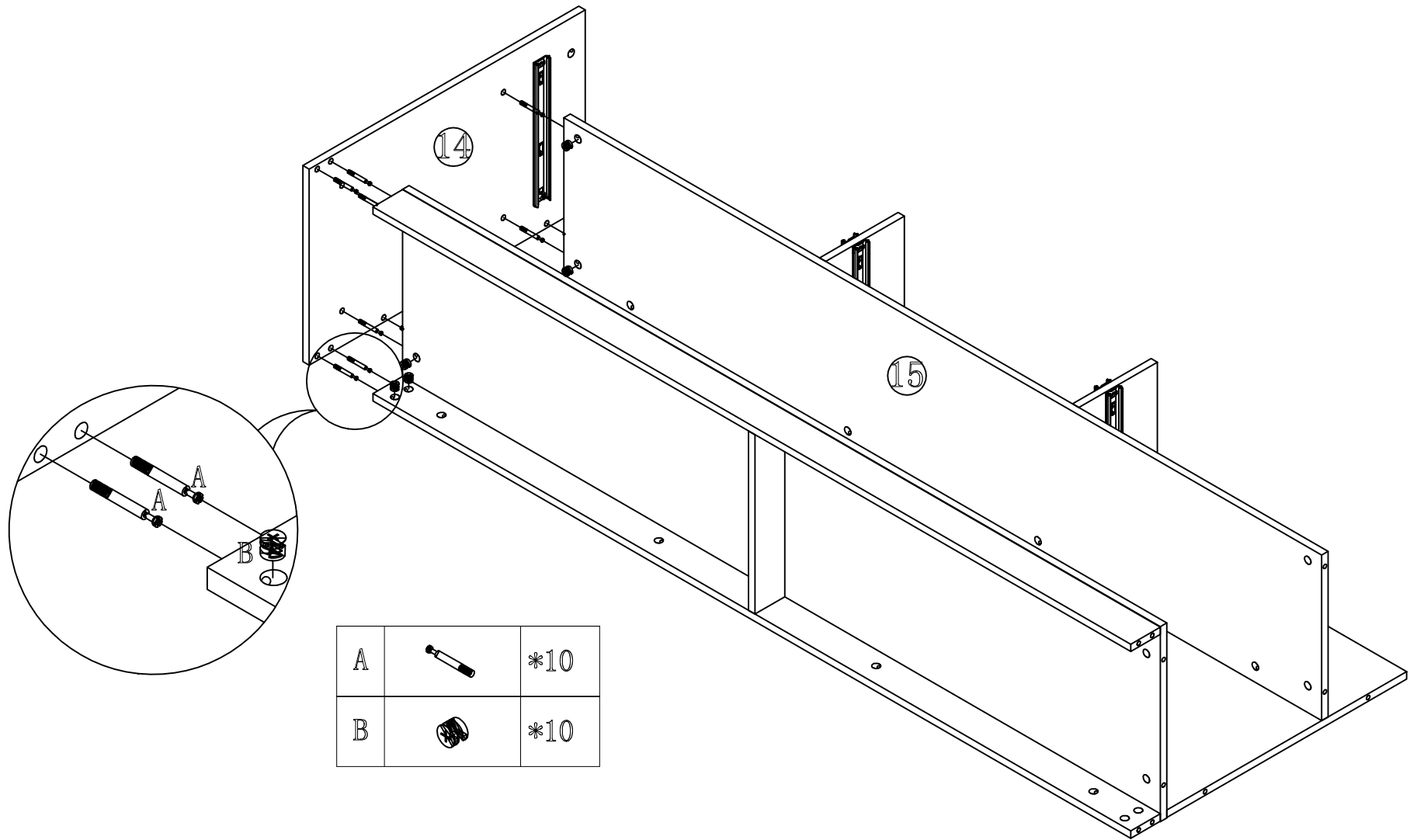

D		*1
F	 3.5*14mm	*4



A		*10
B		*10

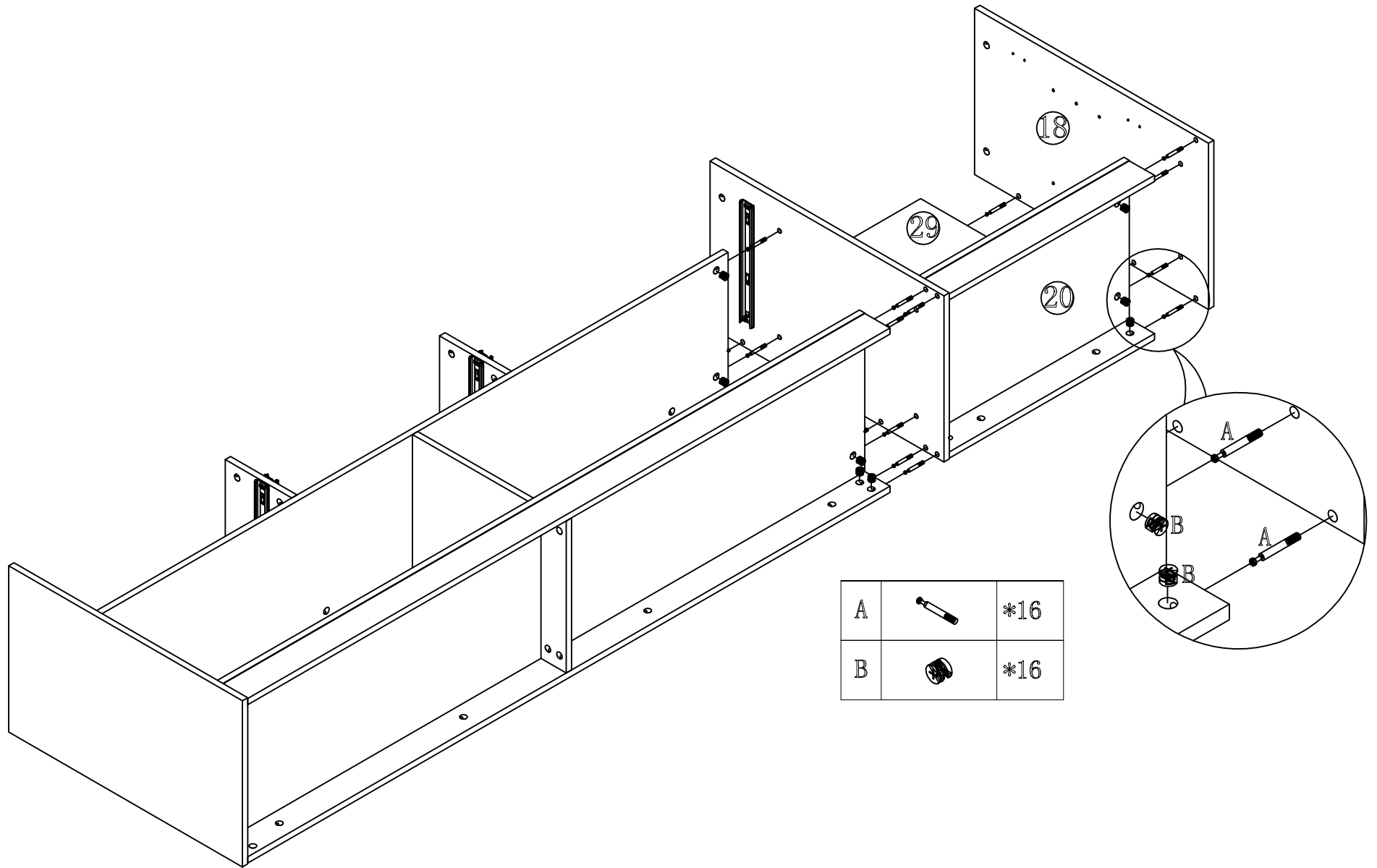

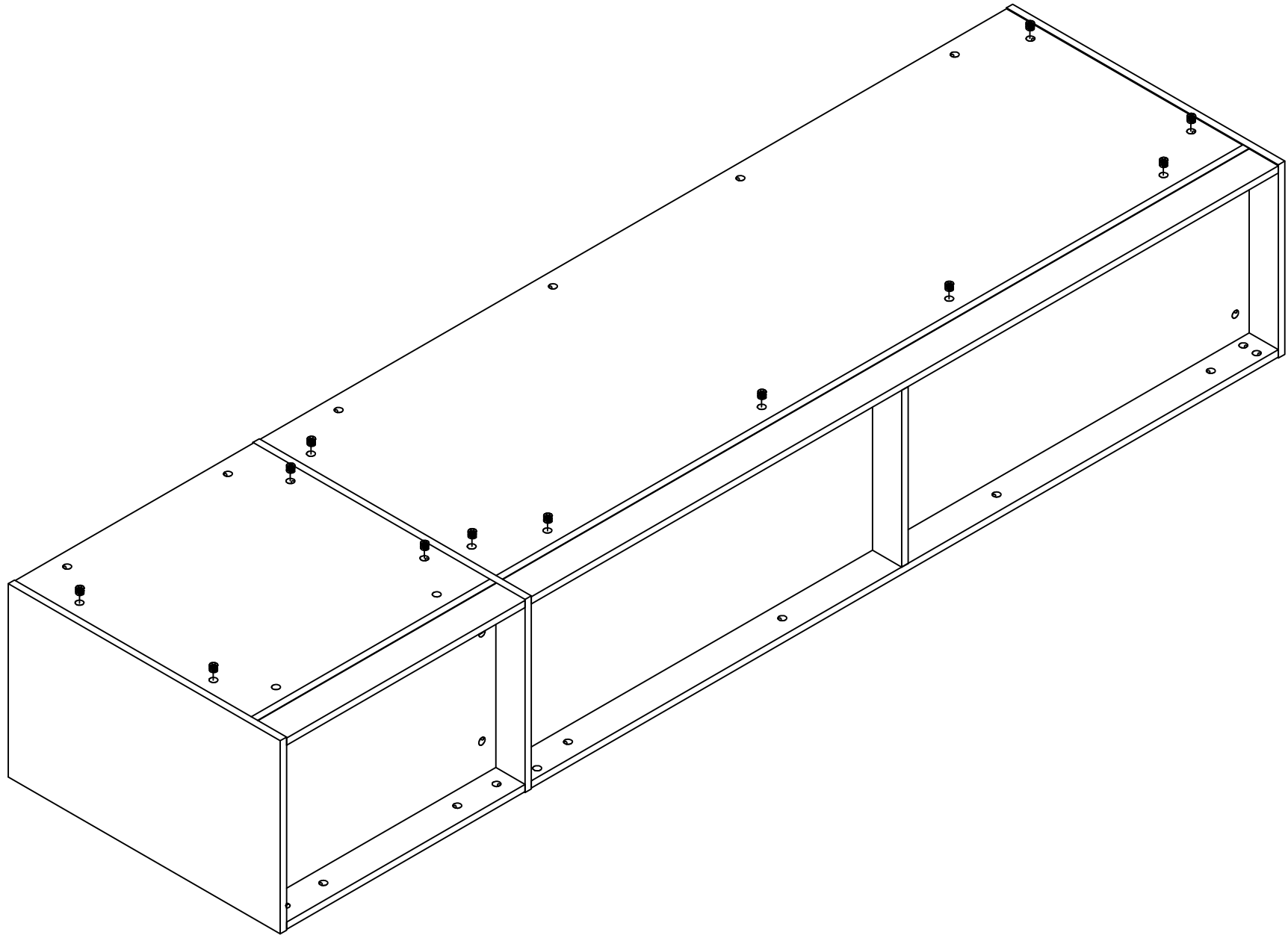

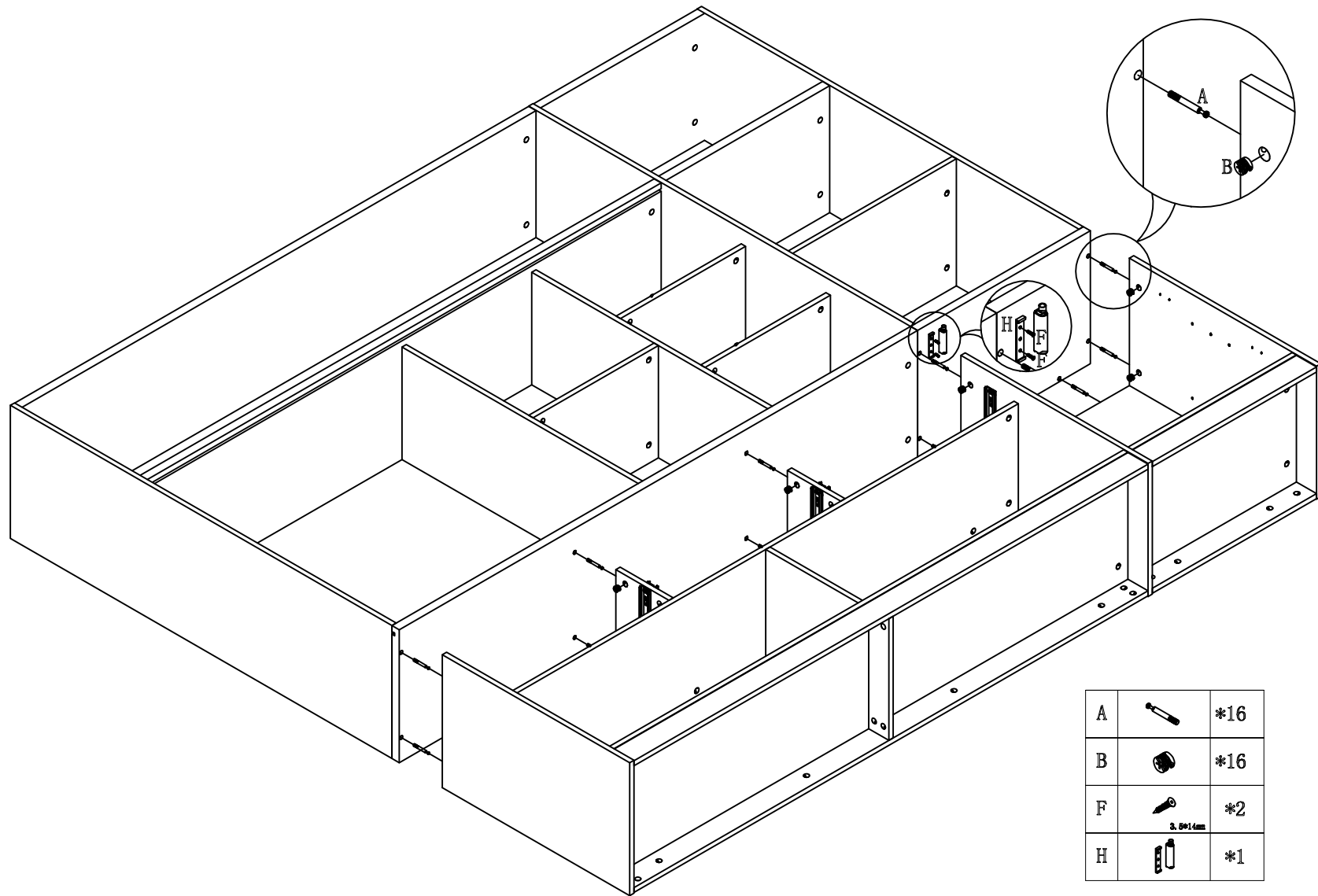

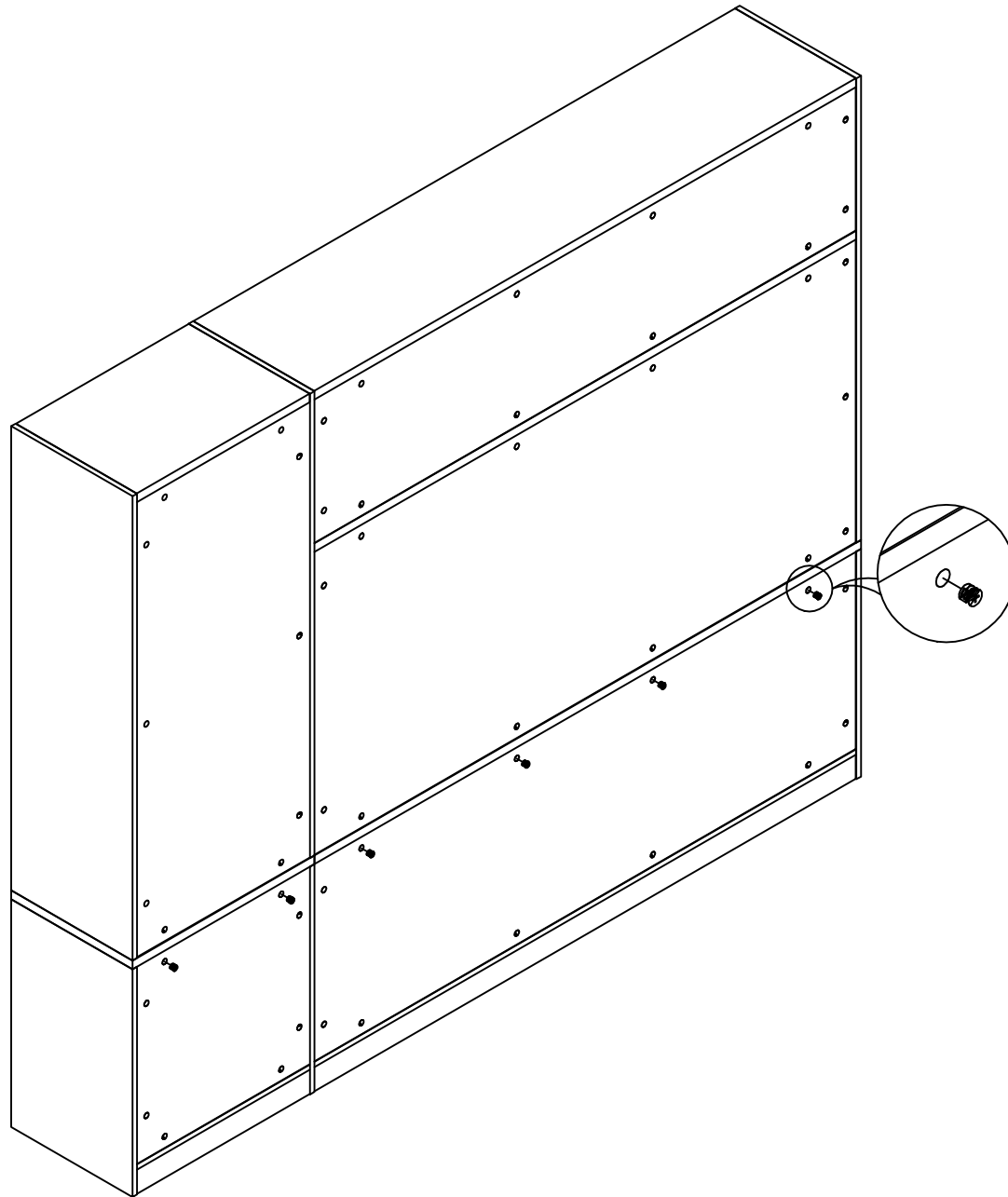

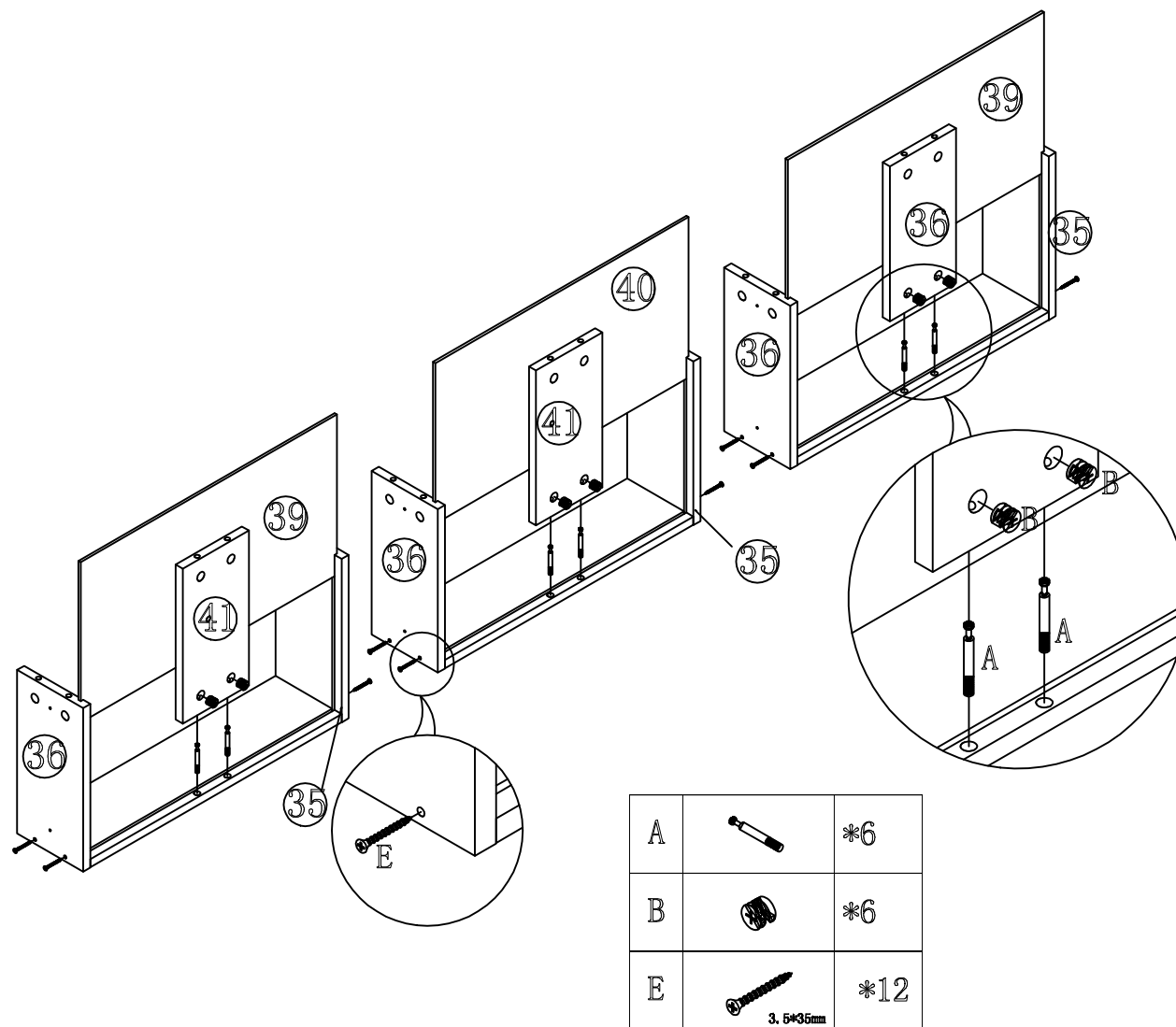

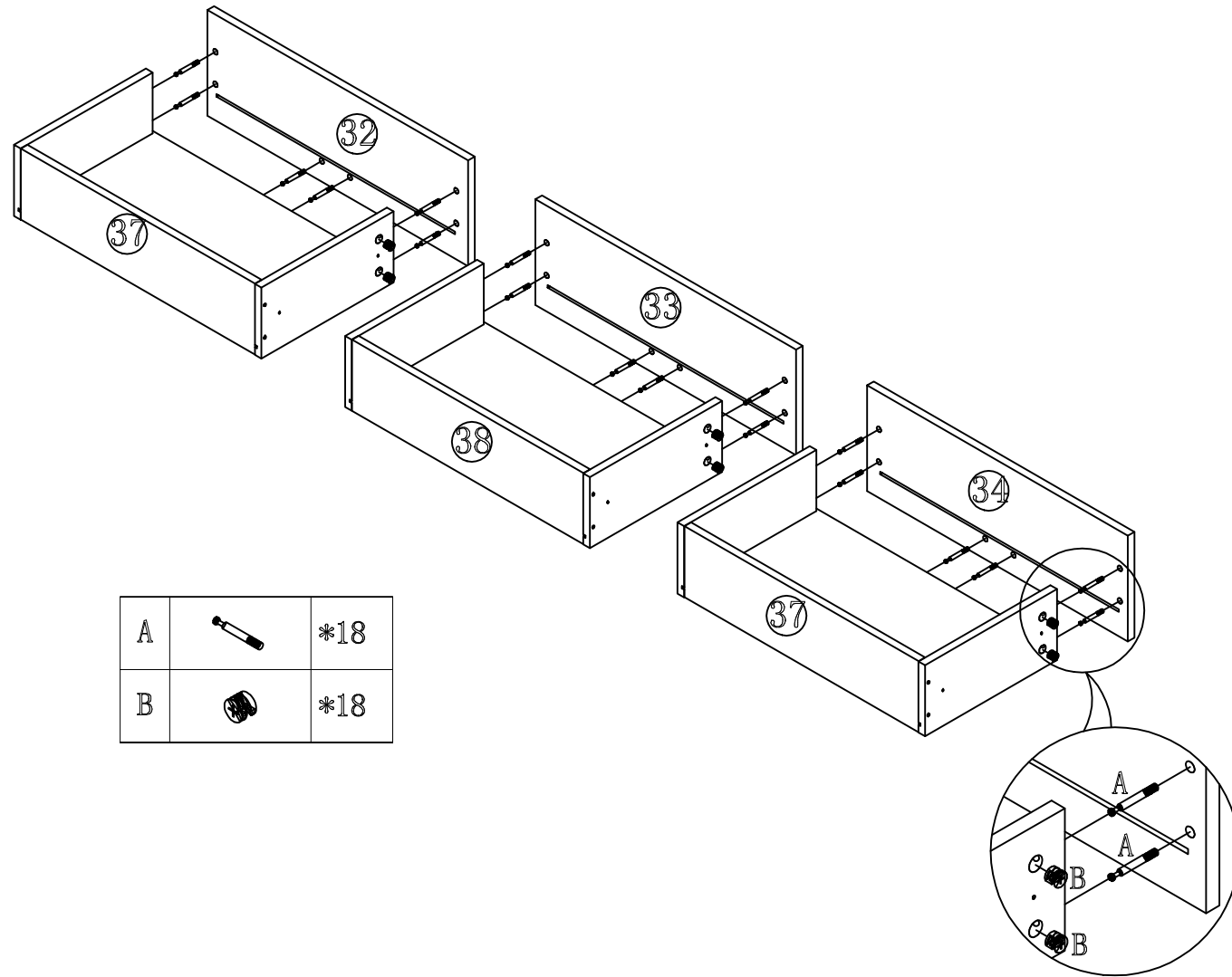





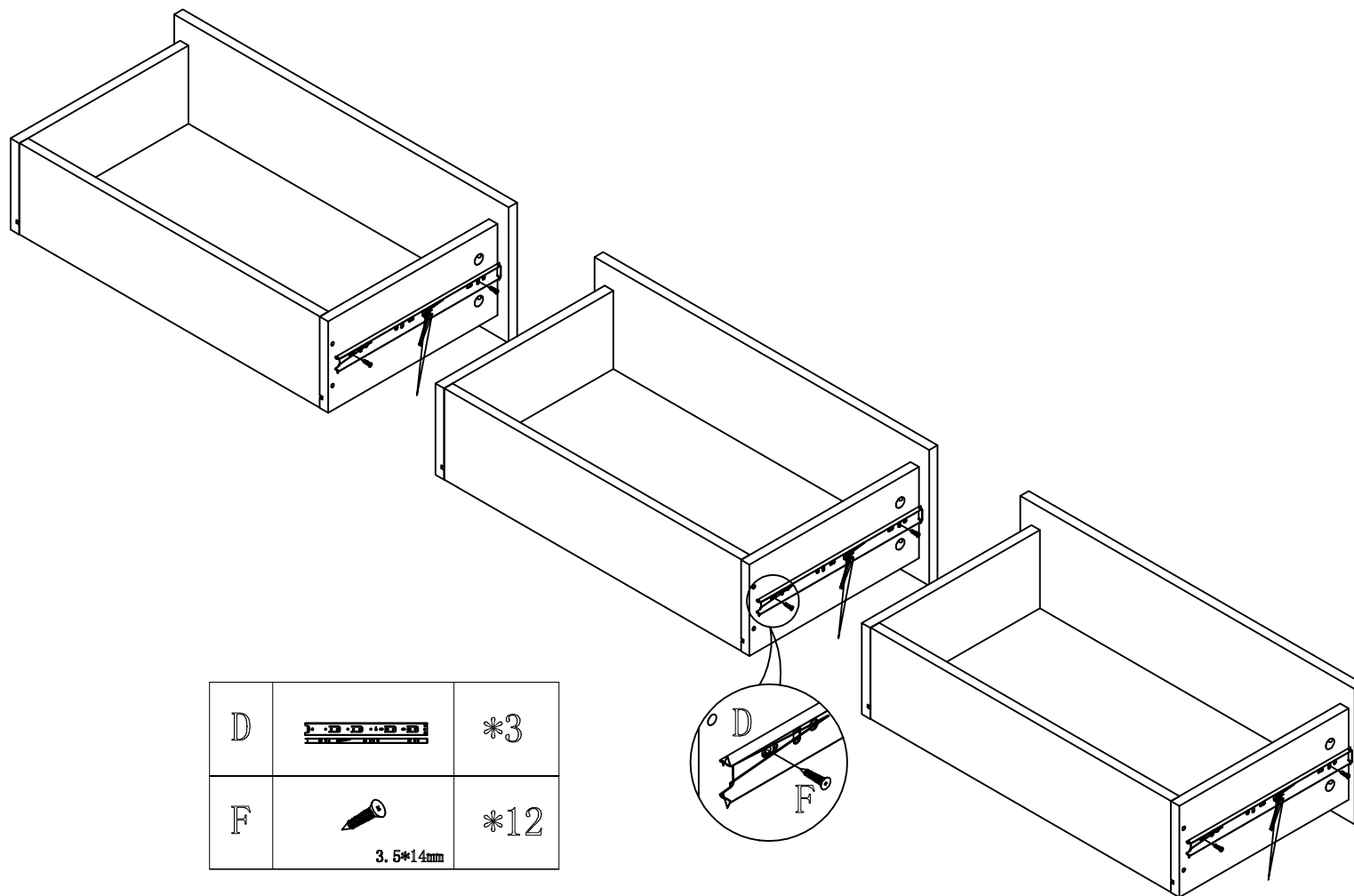

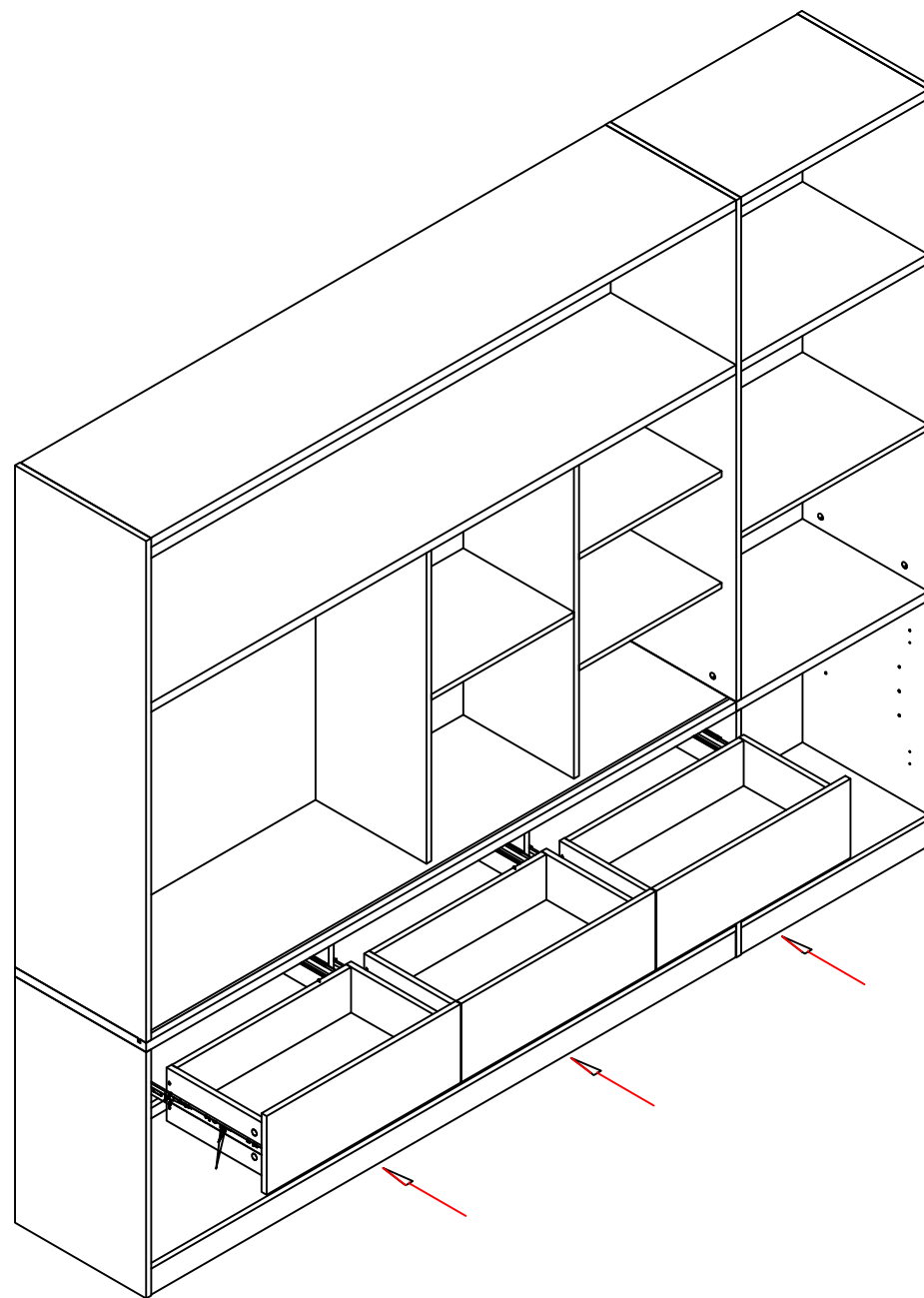
A		*18
B		*18

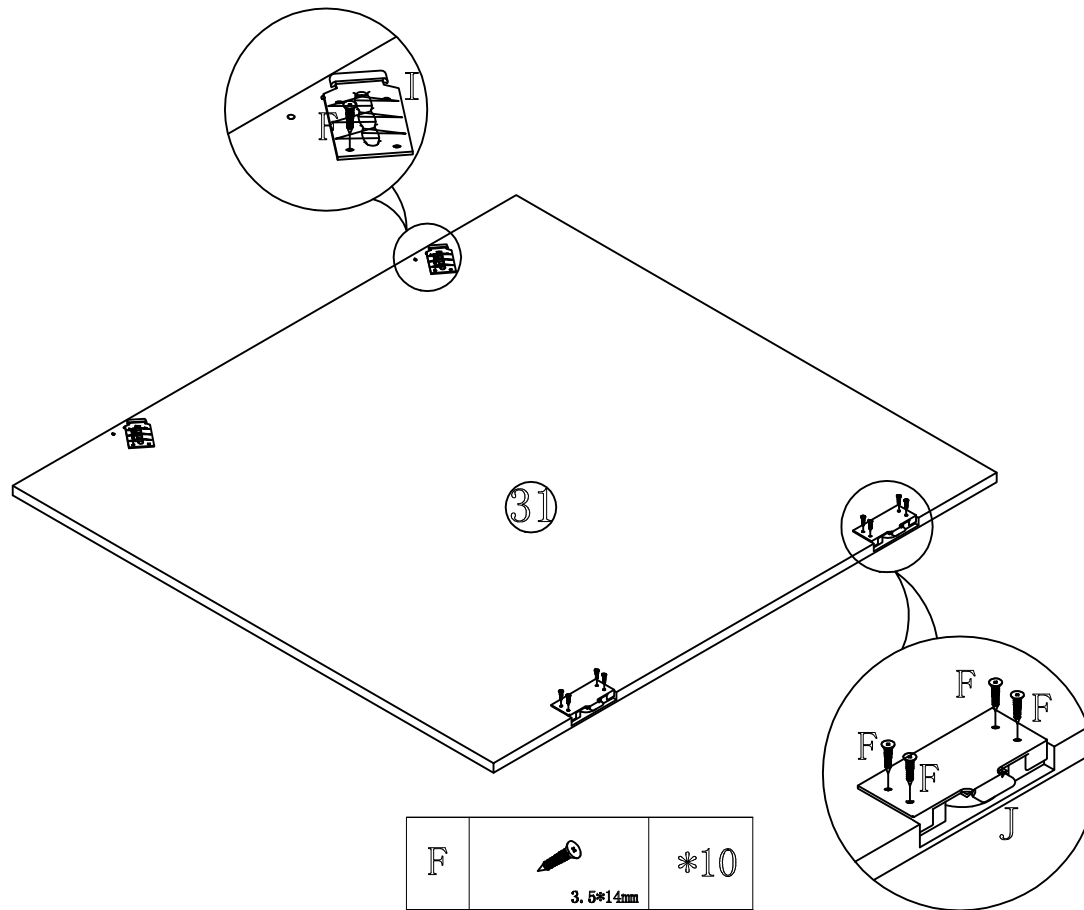







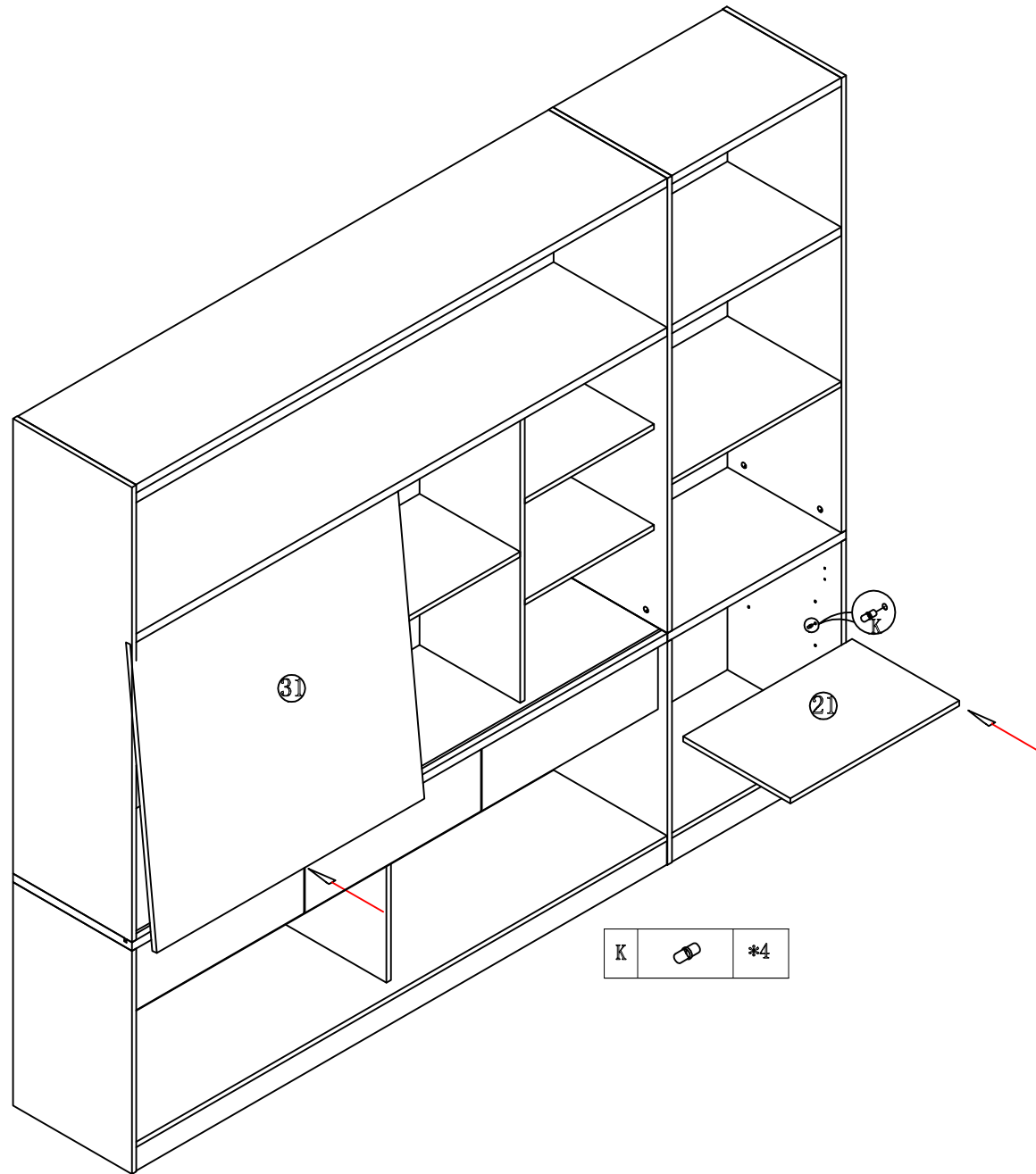

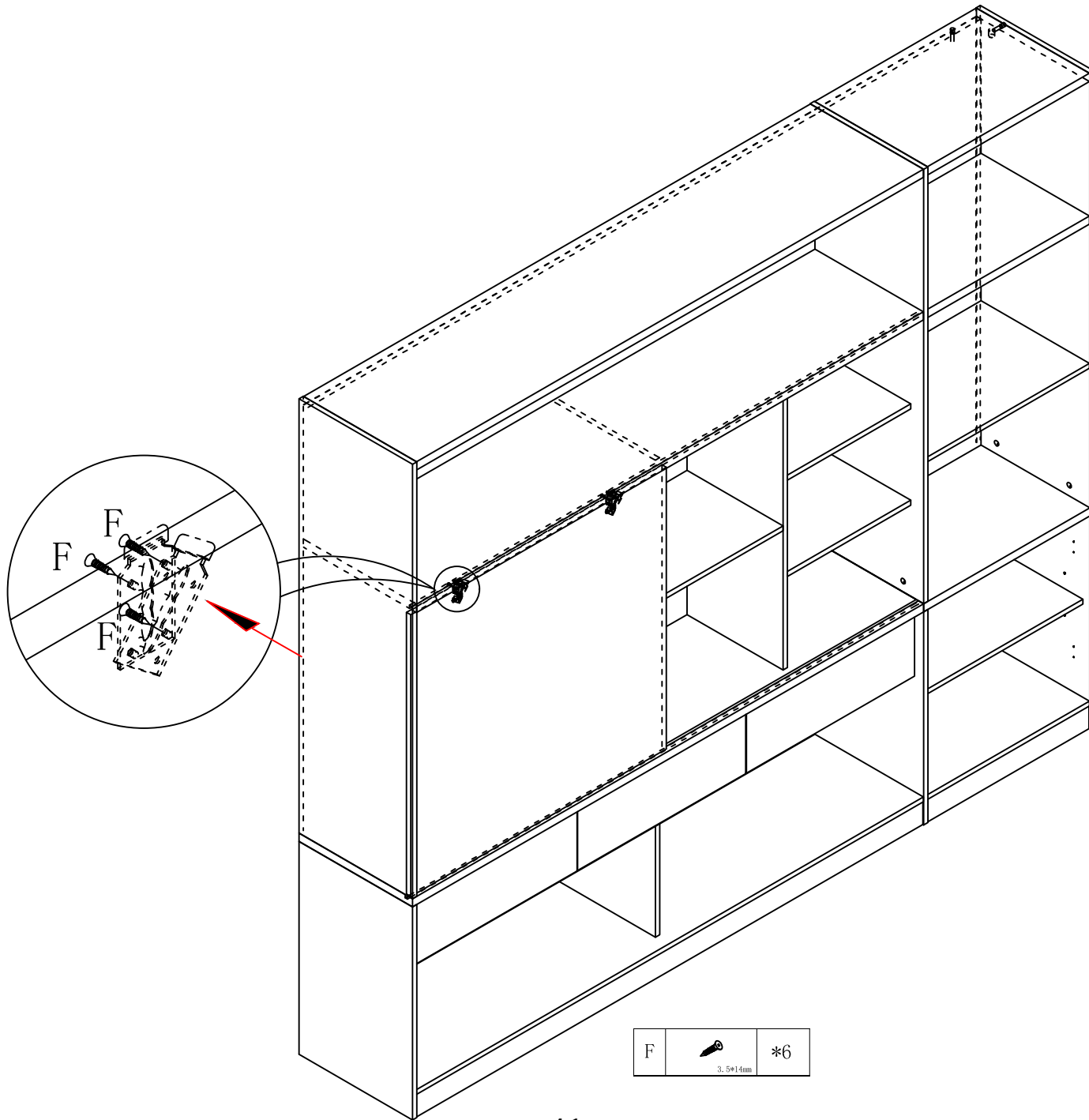
F	 3.5*14mm	*10
I		*2
J		*2

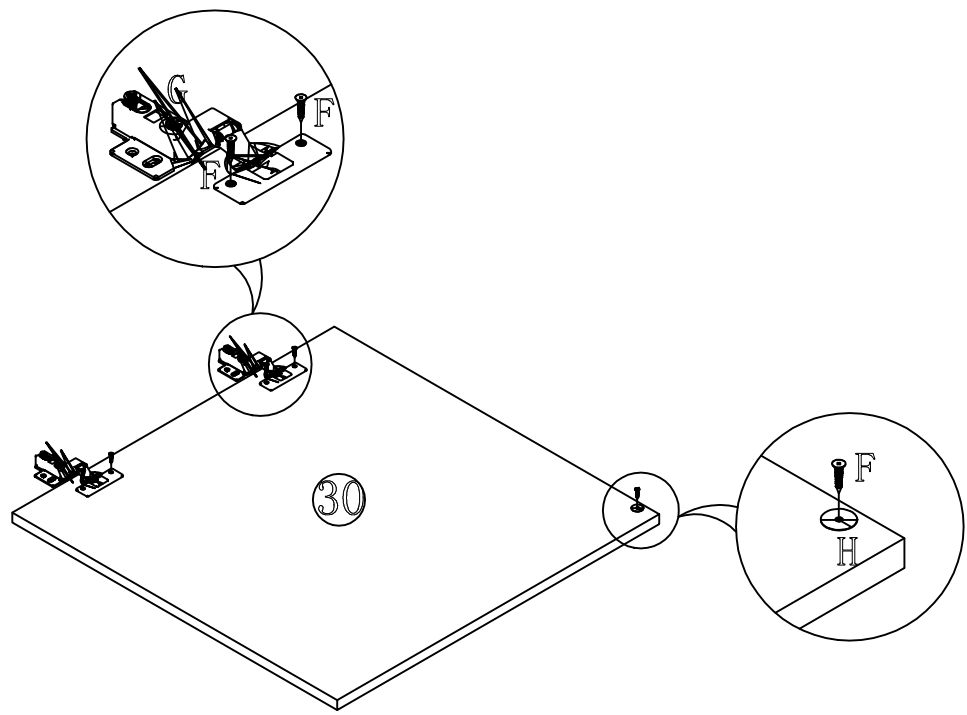





F	 3.5*14mm	*5
G		*2
H		*1

