

# ASSEMBLY INSTRUCTIONS



*Fine Furniture for every stage of life*

***Writing Desk***

# ASSEMBLY INSTRUCTIONS

## ASSEMBLY TIPS:

1. Remove hardware from box and sort by size.
2. Please check to see that all hardware and parts are present prior to start of assembly.
3. Please follow attached instructions in the same sequence as numbered to assure fast & easy assembly.



### WARNING!

1. Don't attempt to repair or modify parts that are broken or defective. Please contact the store immediately.
2. This product is for home use only and not intended for commercial establishments.



ASSEMBLY TIME

30 MINUTES

## PARTS IDENTIFICATION

A	BACK PANEL		1PC
B	LARGE SHELF PANEL		1PC
C	LEFT SIDE PANEL		1PC
D	RIGHT SIDE PANEL		1PC
E	SMALL SHELF PANEL		1PC
F	RIGHT DIVIDER		1PC
G	LEFT DIVIDER		1PC
H	TOP		1PC
I	LEG		4PCS

### NOTE:

Phillips head screw driver is required in the assembly process; however, manufacturer does not provide this item.

# ASSEMBLY INSTRUCTIONS

## ASSEMBLY TIPS:









1. Remove hardware from box and sort by size.
2. Please check to see that all hardware and parts are present prior to start of assembly.
3. Please follow attached instructions in the same sequence as numbered to assure fast & easy assembly.

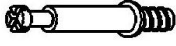

## WARNING!

1. Don't attempt to repair or modify parts that are broken or defective. Please contact the store immediately.
2. This product is for home use only and not intended for commercial establishments.

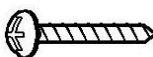
## HARDWARE IDENTIFICATION

1	<b>CAM BOLT</b> (24mm - RBW)		15PCS
2	<b>CAM NUT</b> (9mm - RBW)		15PCS
3	<b>BOLT</b> (M8 x 60mm - RBW)		8PCS
4	<b>LOCK WASHER</b> (5/16" - RBW)		8PCS
5	<b>FLAT WASHER</b> (5/16" - RBW)		8PCS
6	<b>WOOD DOWEL</b> (M8X30mm)		22PCS
7	<b>SHELF SUPPORT</b> (5mm)		4PCS
8	<b>PAN HEAD SCREW</b> (#8 x 1/4" - BLK)		2PCS
9	<b>ALLEN WRENCH</b> (M5 - BLK)		1PC

## NOTE:

Phillips head screw driver is required in the assembly process; however, manufacturer does not provide this item.

# ASSEMBLY INSTRUCTIONS

## STEP 1

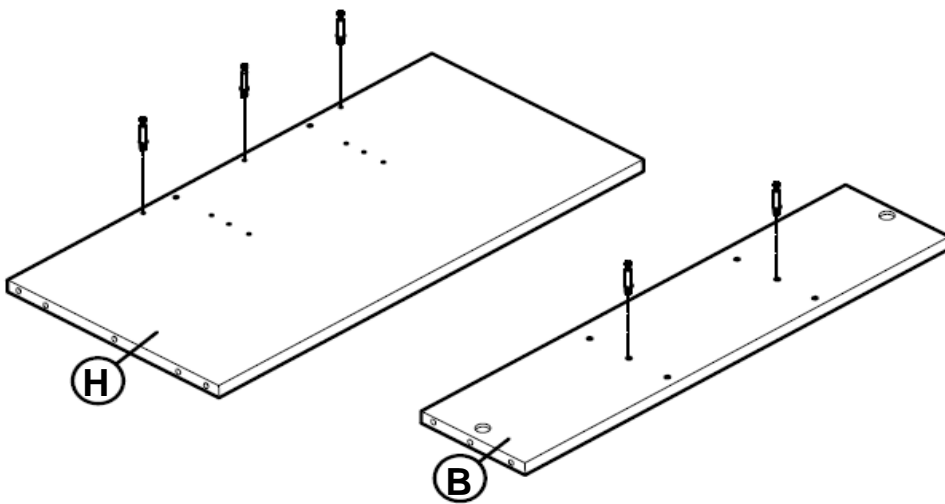
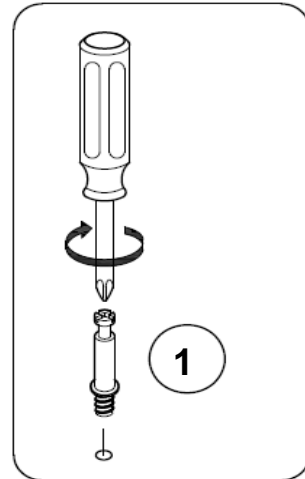
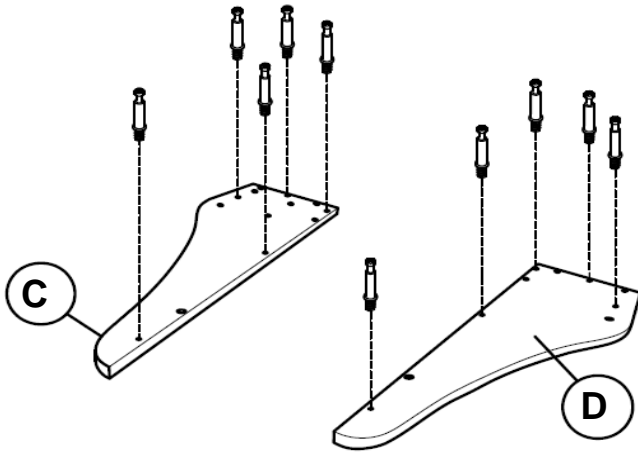

## STEP 2

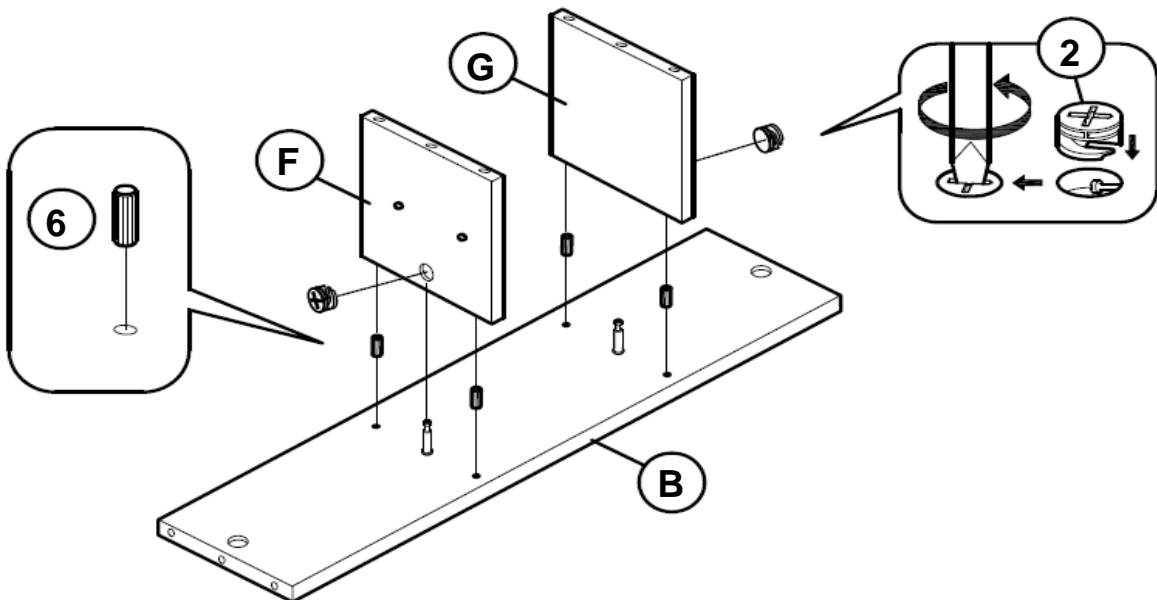

# ASSEMBLY INSTRUCTIONS

## STEP 3

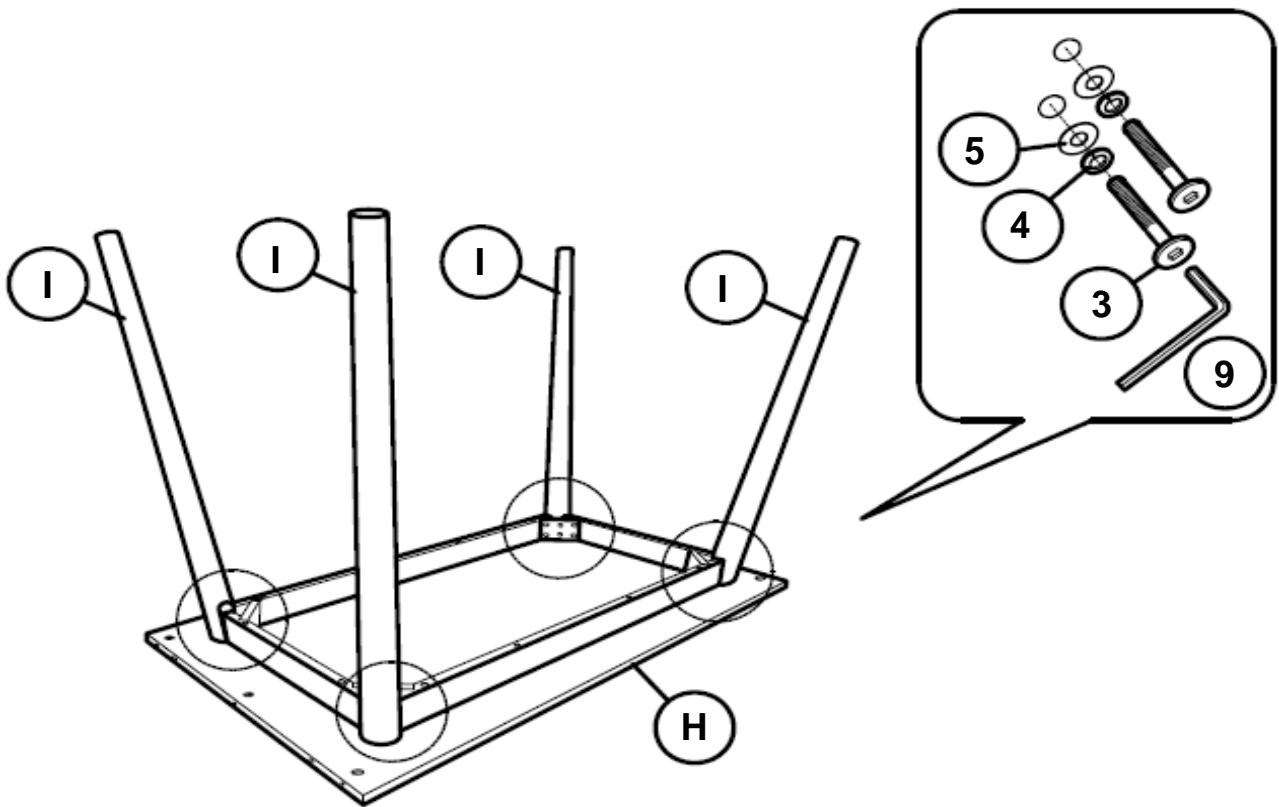

## STEP 4

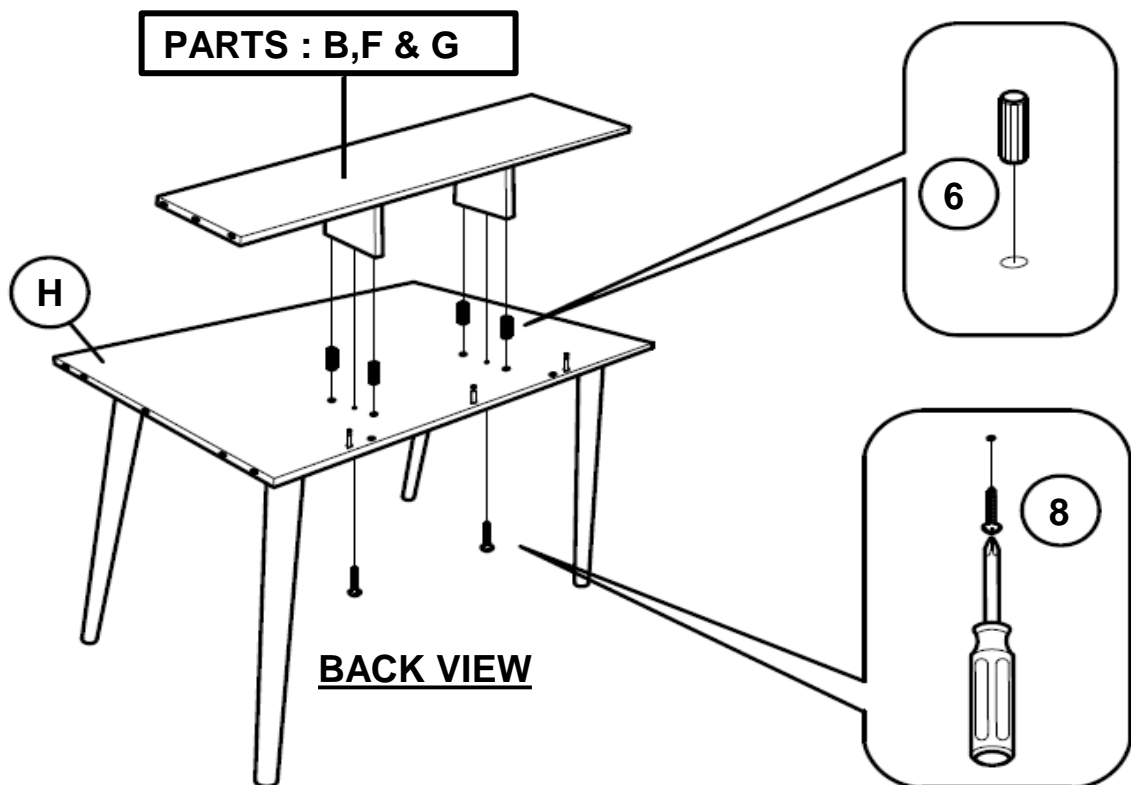

**ASSEMBLY INSTRUCTIONS**  
**STEP 5**

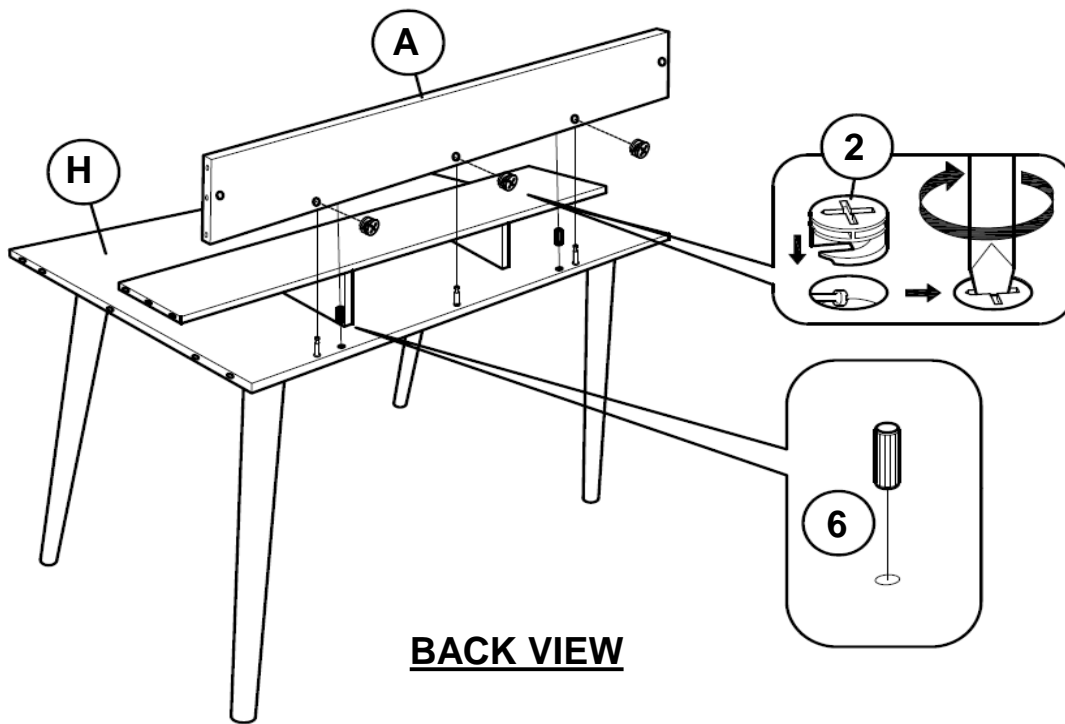

**STEP 6**

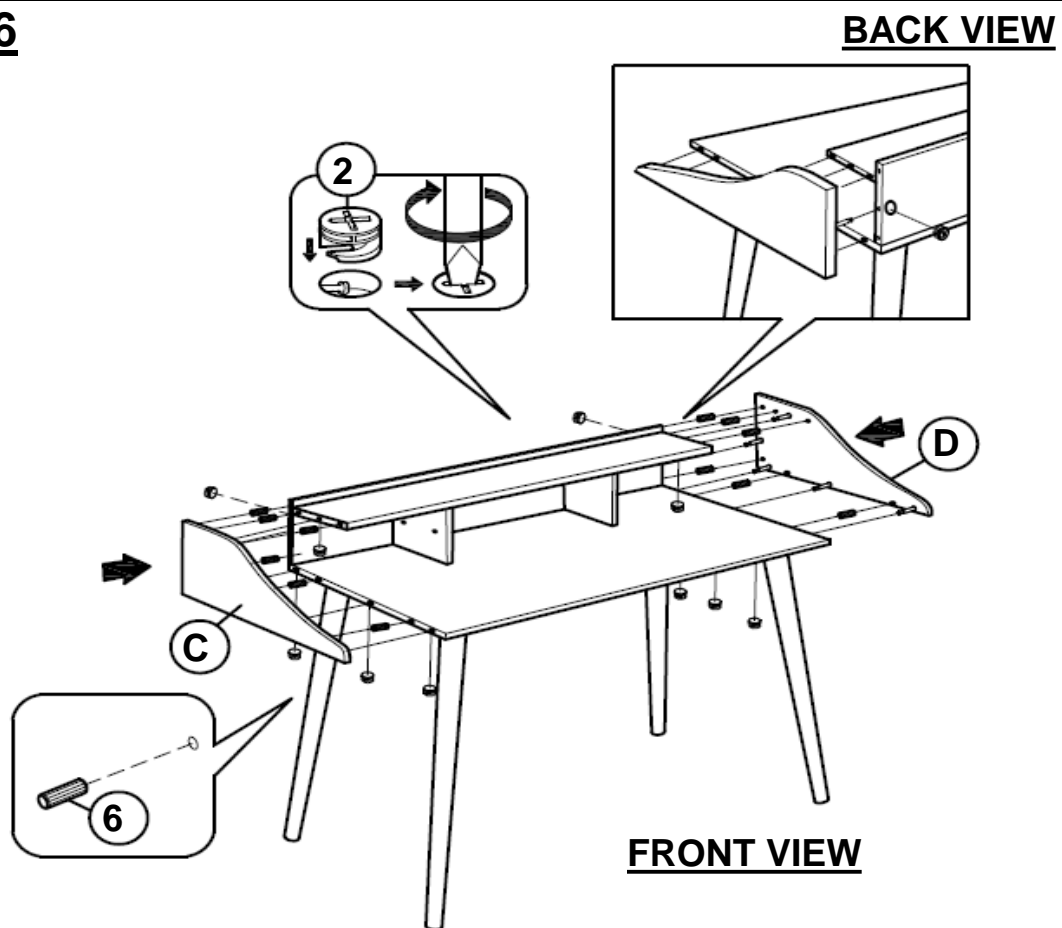

**ASSEMBLY INSTRUCTIONS**  
**STEP 7**

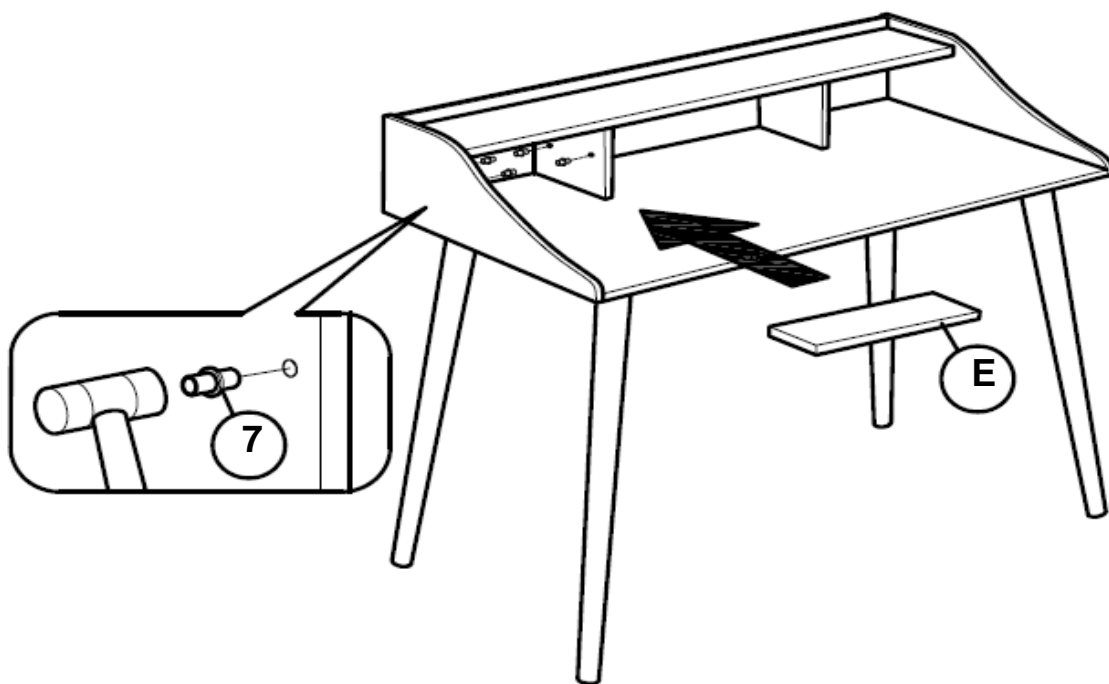

**STEP 8**  
**COMPLETE**

