



626-679-3588
service@getprohome.com
www.getprohome.com
162 Atlantic St, Pomona, CA 91768

INSTALLATION GUIDE

CONSOLE SINK

service@getprohome.com
626 679 3588



PRODUCT
INSTRUCTION
VIDEO



THANK YOU!

Dear Valued Customer,

Thanks to your kind support of GETPRO, we hope our product can improve the quality of your life.

As our valued customer, your comments and opinions are very important to us. If you have any concerns, questions, or comments, we hope that you will bring them to our attention.

Please keep the carton and packaging materials until your product is completely installed.

Feel free to contact us if you encounter any problems such as missing parts, or product defects during the installation process. We are happy to provide you with the most sincere service.

*Sincerely,
Service Team*

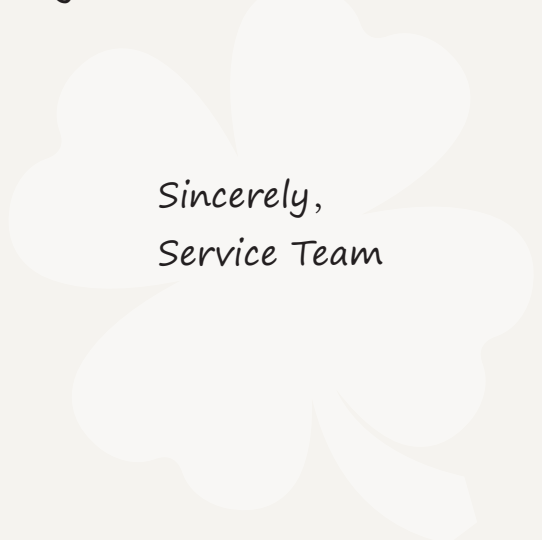

INSTALLATION GUIDE

CABINET PARTS DISASSEMBLY DIAGRAM

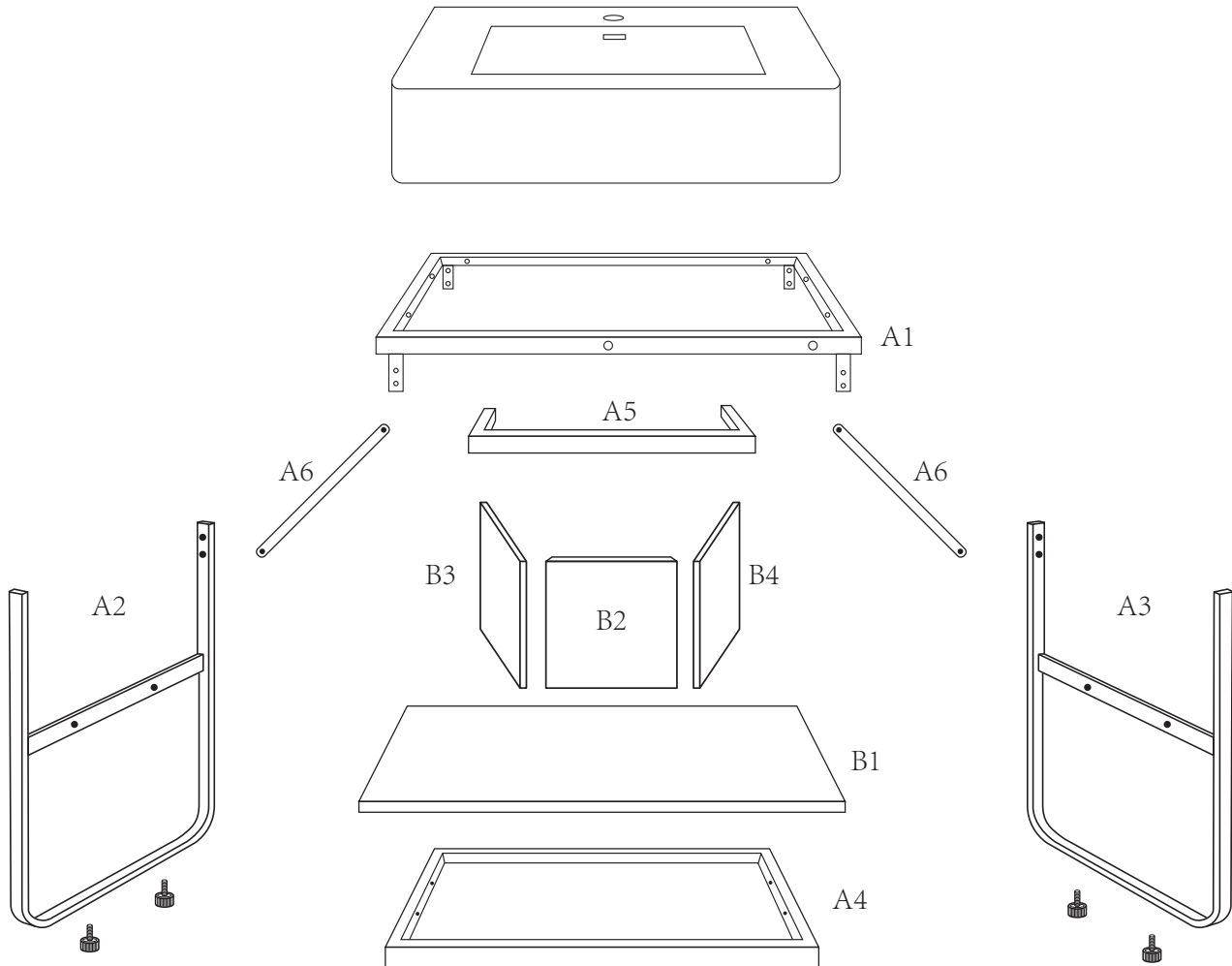

ACCESSORY DIAGRAM

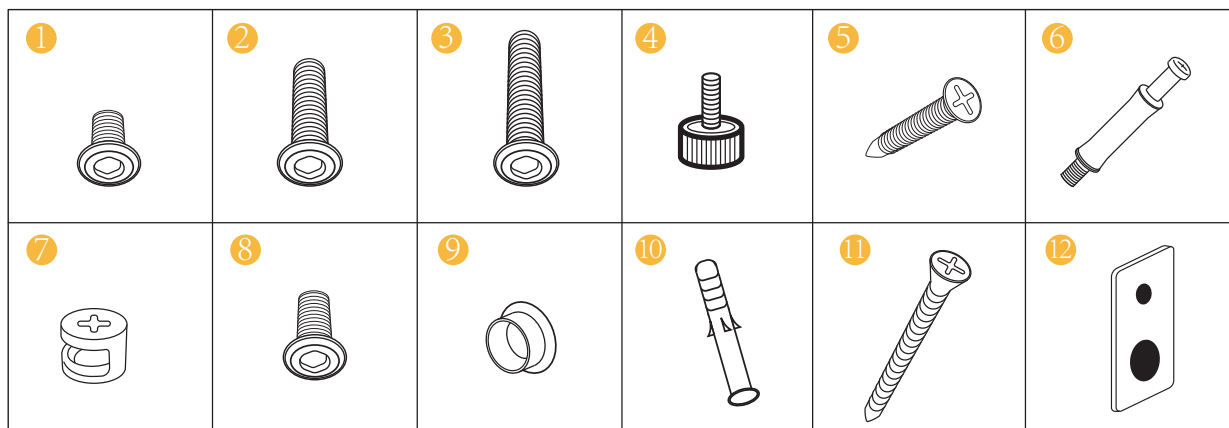

INSTALLATION GUIDE

Installing a bathroom vanity can vary depending on the specific type and design of the vanity, as well as your bathroom setup. Here are some general steps to guide you through the process:



NOTE: A drain pipe and trap are not included with this vanity.

- 1. Prepare the area:** Clear out the space where the vanity will be installed. Ensure the plumbing lines are in place and ready for connection.
- 2. Measure the space:** Measure the dimensions of the vanity and the available space in your bathroom to ensure it will fit properly.
- 3. Turn off the water supply:** Before starting any work, be sure to turn off the water supply to the bathroom.
- 4. Remove the old vanity:** If there is an existing vanity, you will need to disconnect the plumbing, remove the sink, and take out the old vanity.

TOOLS REQUIRED



Electric screwdriver



Screwdriver

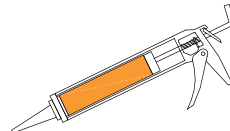

silicone adhesive sealant



Pencil

STEP 1

Insert A2, A3 into A1 and secure them with screw ①.

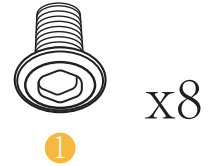

※ Note that the hole positions of A2 and A3 should be oriented the same way, and the hole positions on the back of A1 should be in the same direction.

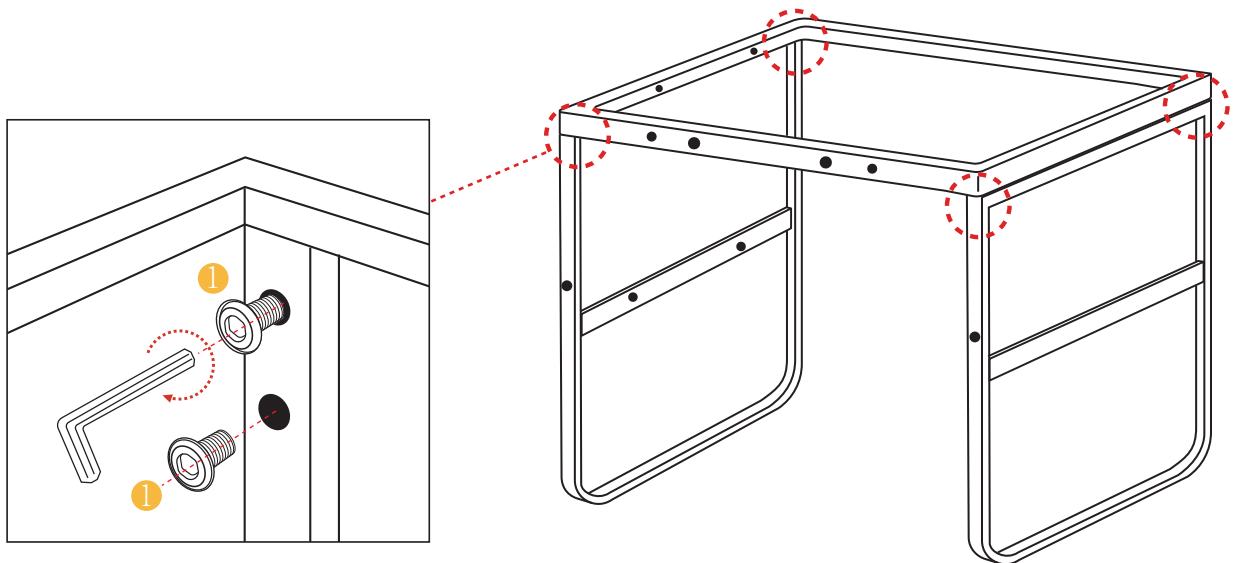
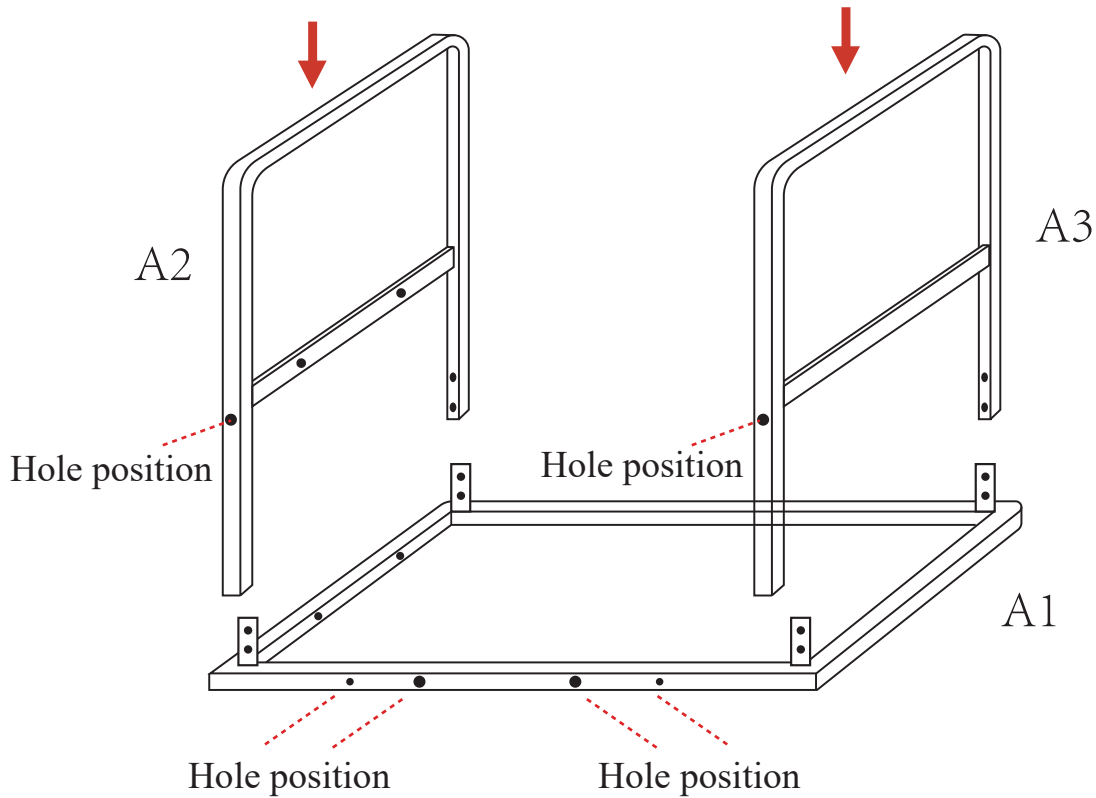

STEP 2

Use screw ③ to secure A4.

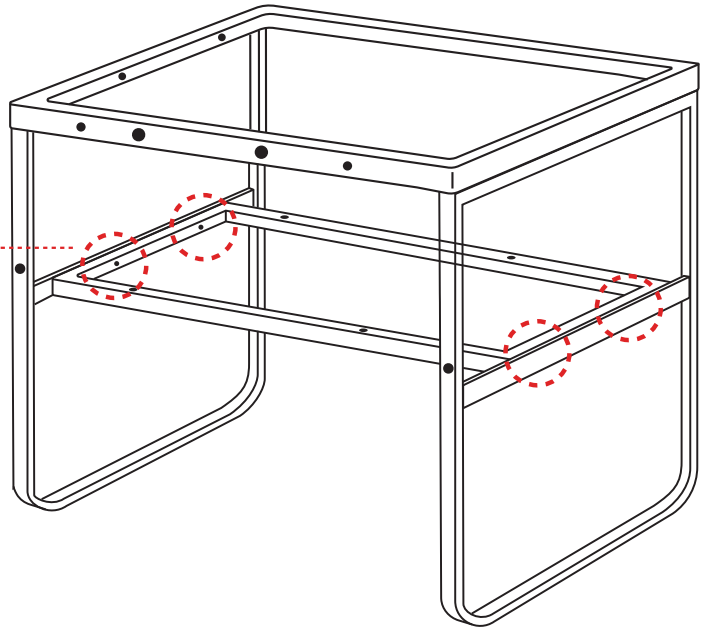
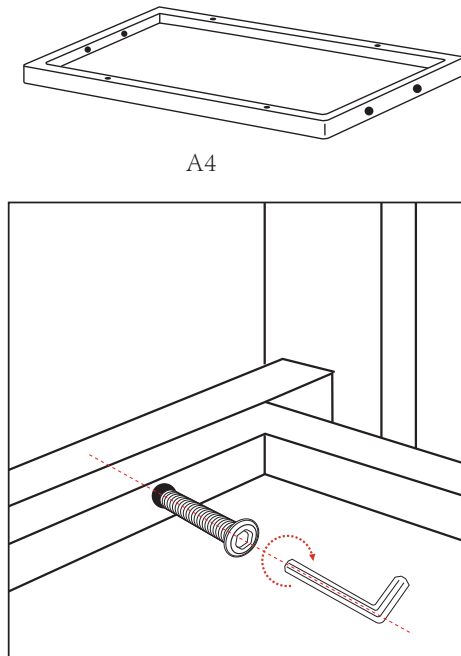
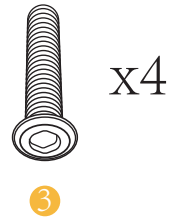

STEP 3

Use screw ① to secure A6.

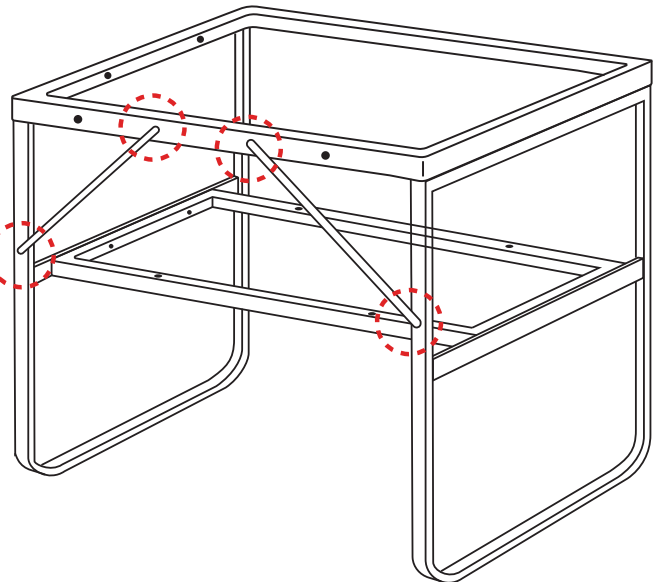
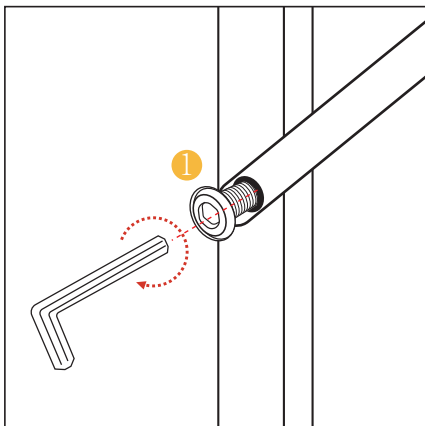
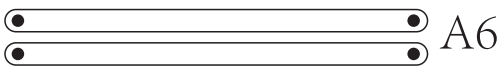
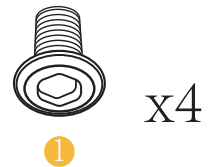

STEP 4

Use screw ② to secure A5.

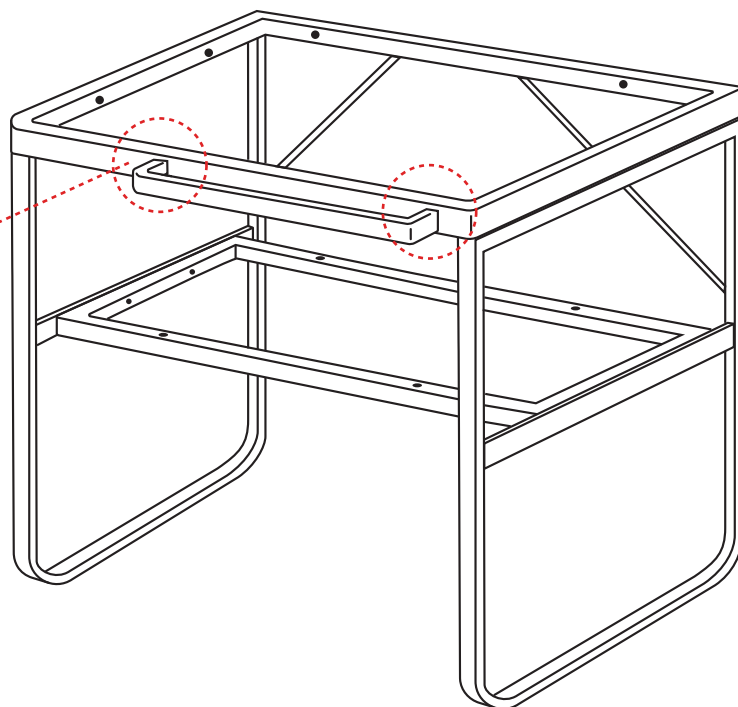
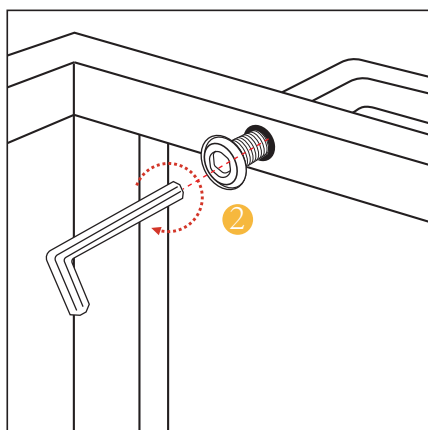
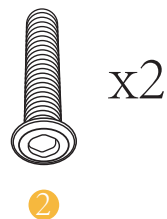

STEP 5

Install the adjustable feet ④ at the bottom of the stand legs and ensure it is level.

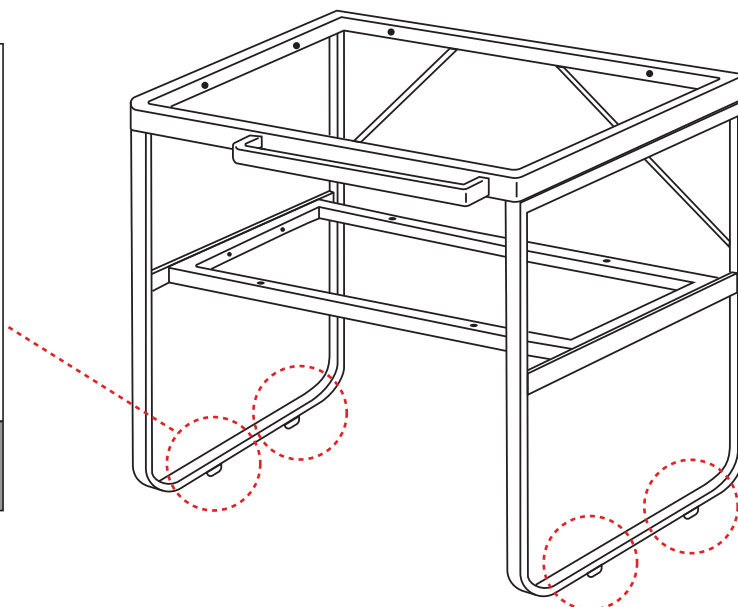
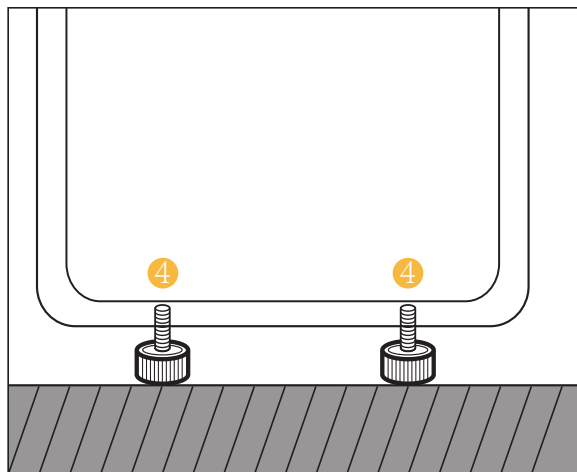
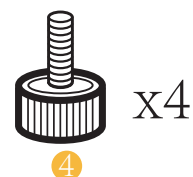

STEP 6

Use screw 8 to install accessory 12 on the top of the stand, making sure to use the larger diameter holes.

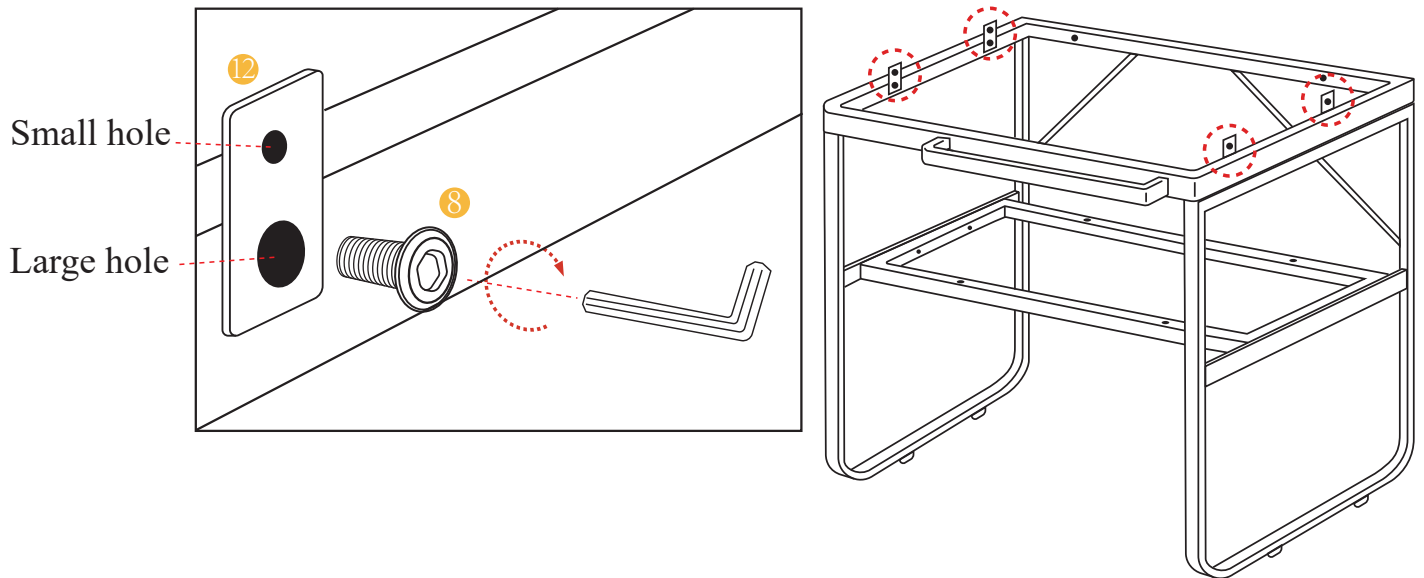

STEP 7

Use screw 5 to secure B1 on top of A4.

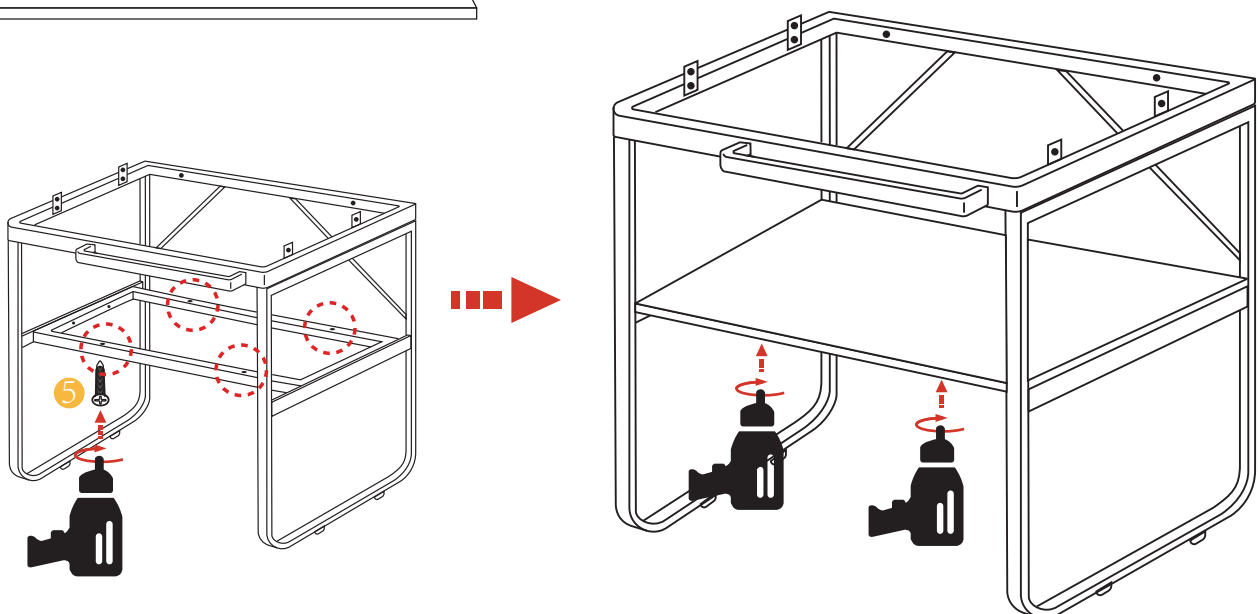
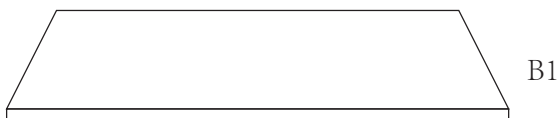
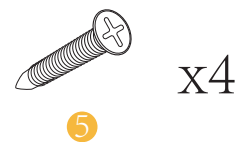

STEP 8

Use part 6 and 7 to assemble the decorative panel.

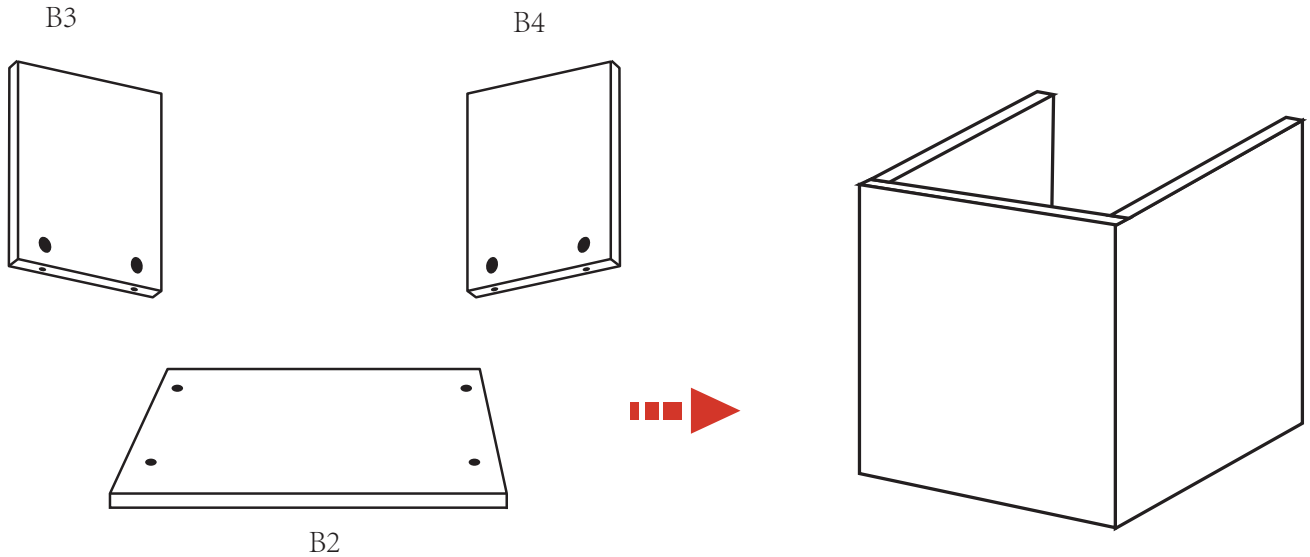

Attention: Stop tightening the screws until they meet the rubber particles, and do not over-tighten to prevent the screws from deforming.

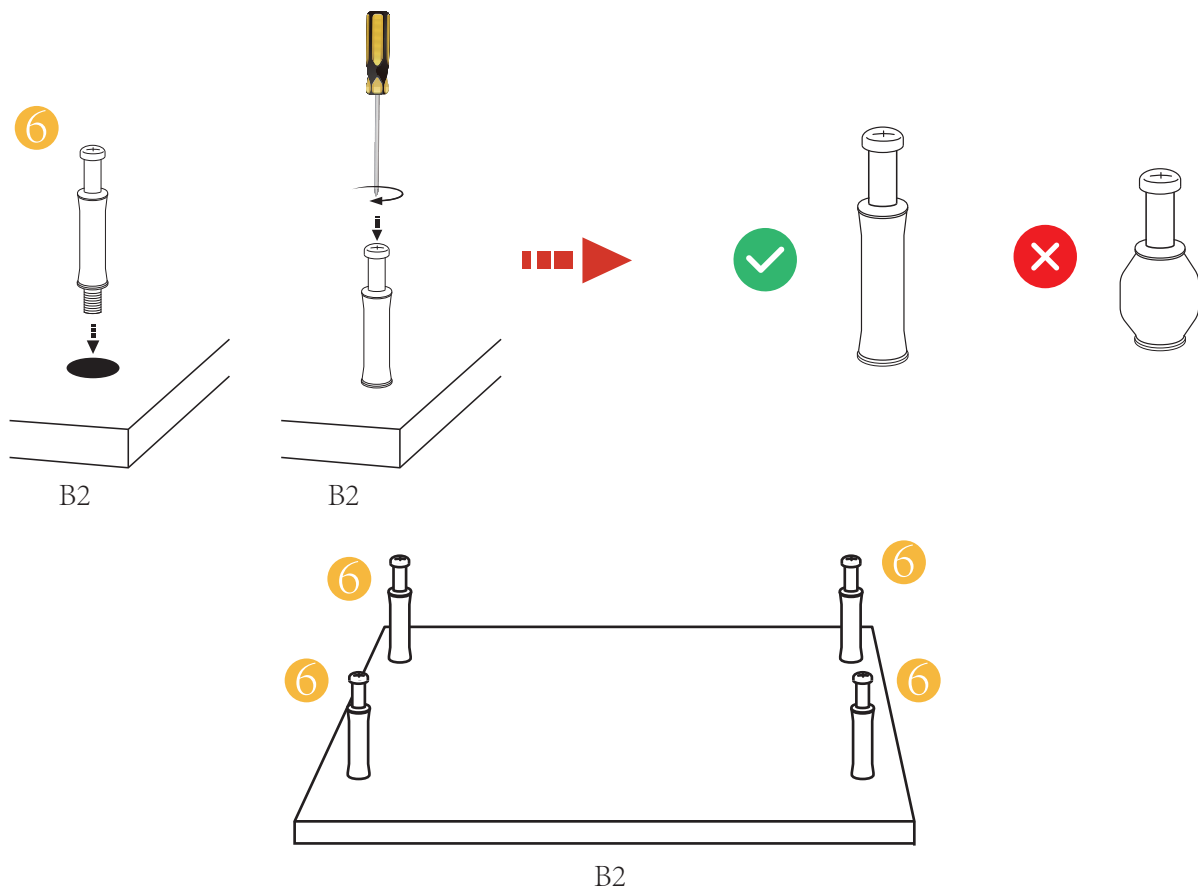

Insert Part **7** into B3 and B4, connecting it with B2.

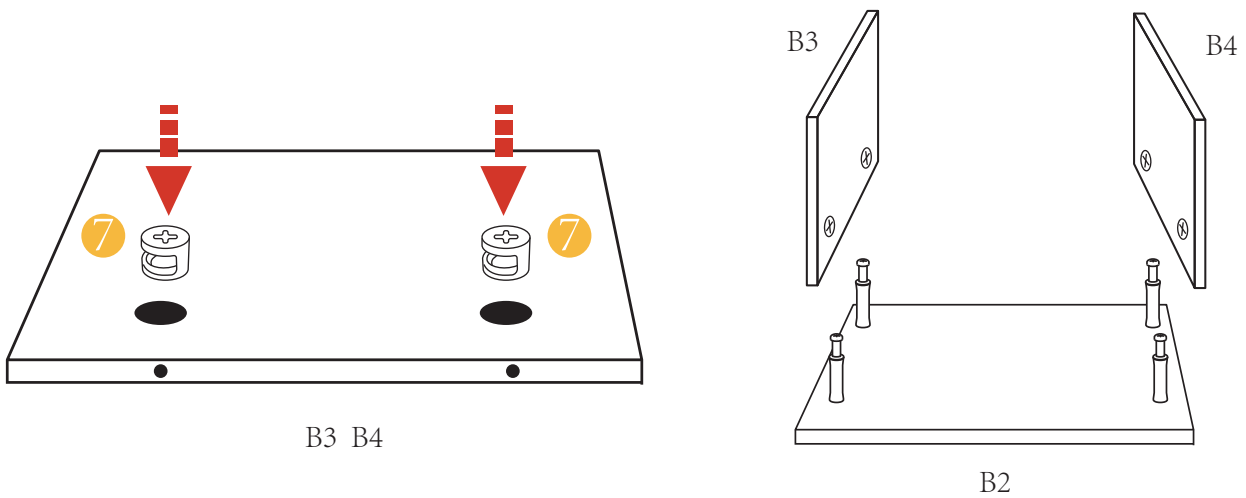

After the panels are spliced, you can rotate the cross screw holes of the panels clockwise to lock the panels, and rotate the cross screw holes of the panels counterclockwise to unlock and remove the panels.

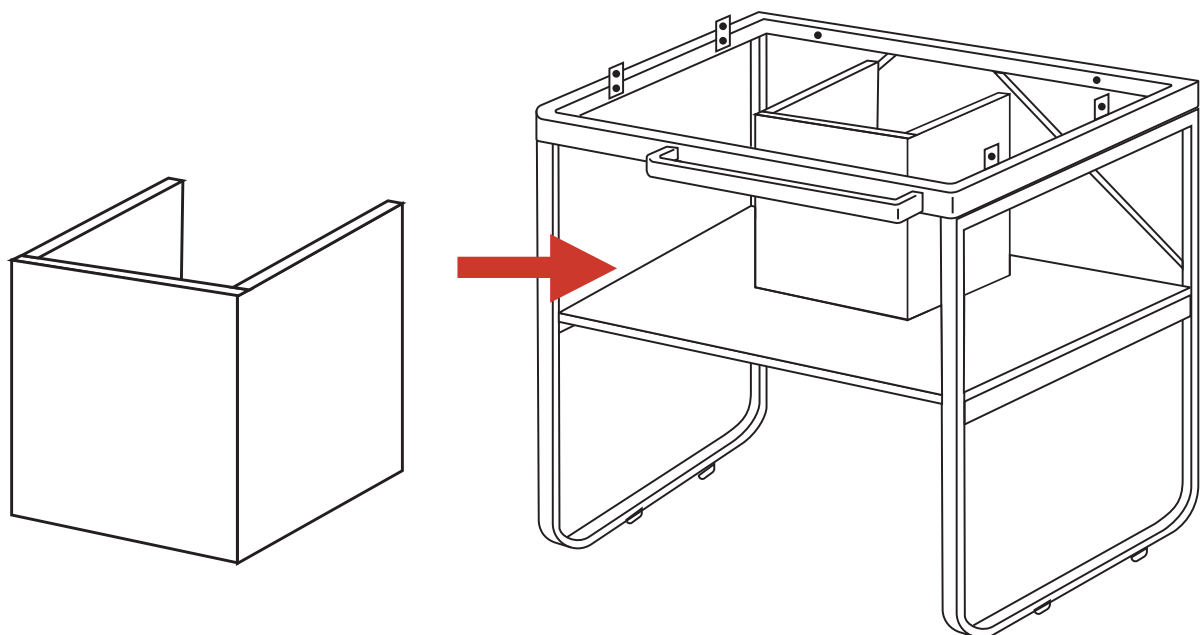

STEP 9

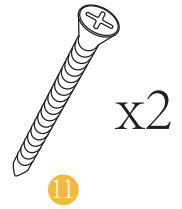
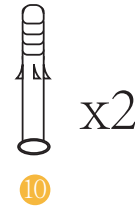

Fix the cabinet to the wall. Use a pencil to mark locations where holes need to be drilled, then drill holes in the wall. Insert the **10** accessory into the holes, move the cabinet to the corresponding holes, use the **11** accessory to pass through the A1 accessory and tighten them, finally install the accessory.

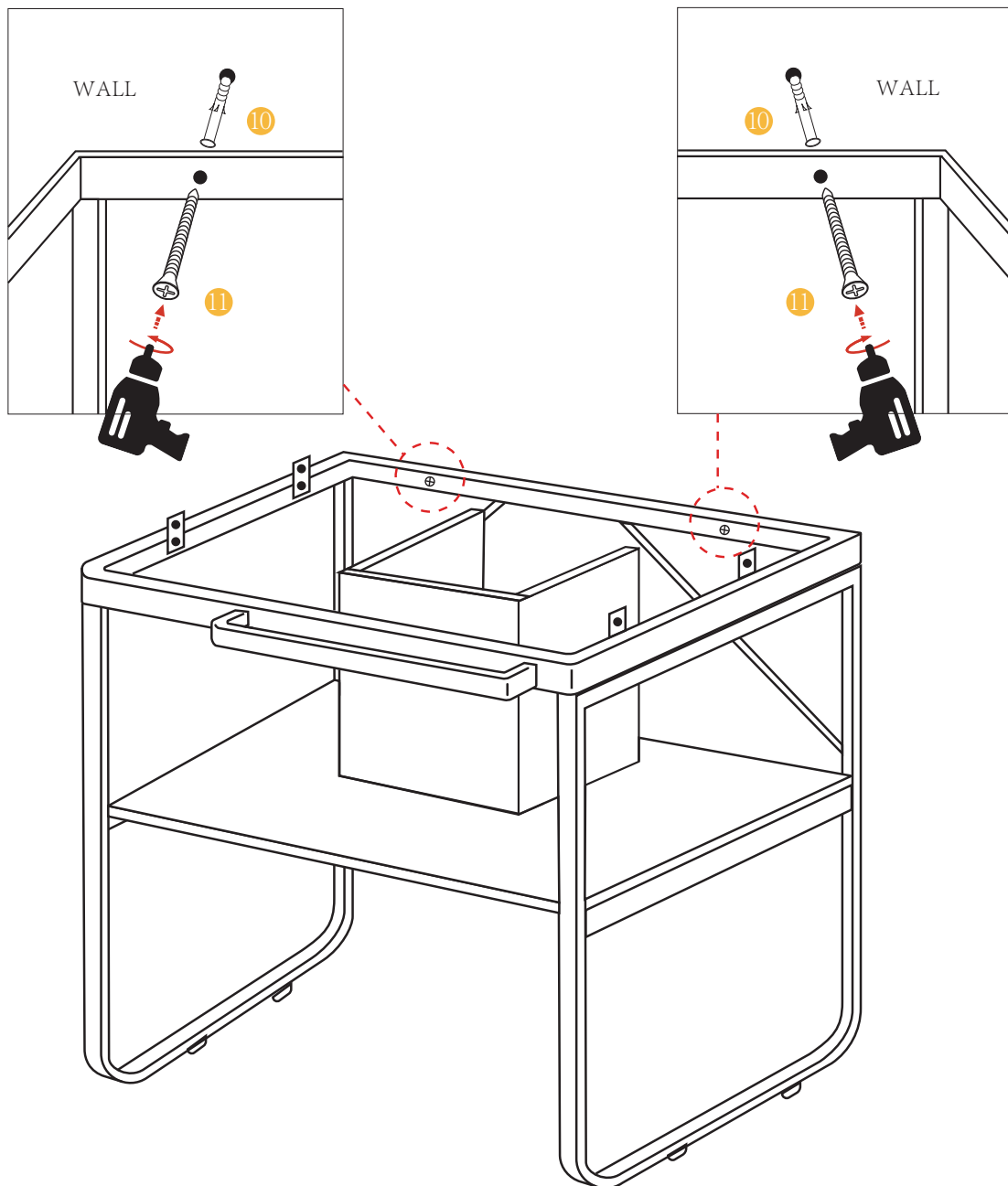

STEP 10

1. Seal the Edges: To prevent water damage and ensure a clean finish, apply a bead of silicone caulk along the edges where the countertop meets the stand.

2. Attach the sink top:
Secure the sink on the stand.

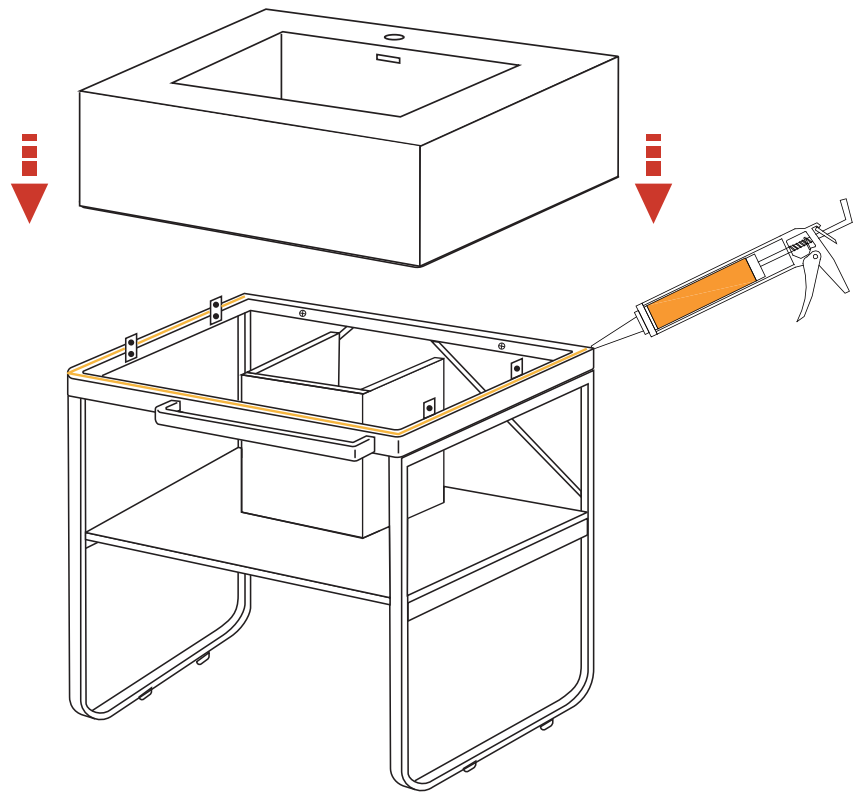

STEP 11

Use screw ② to pass through part ⑫, and then place the soft cover ⑨ over it. Tighten slightly to secure the sink (do not over-tighten to prevent the sink from cracking).

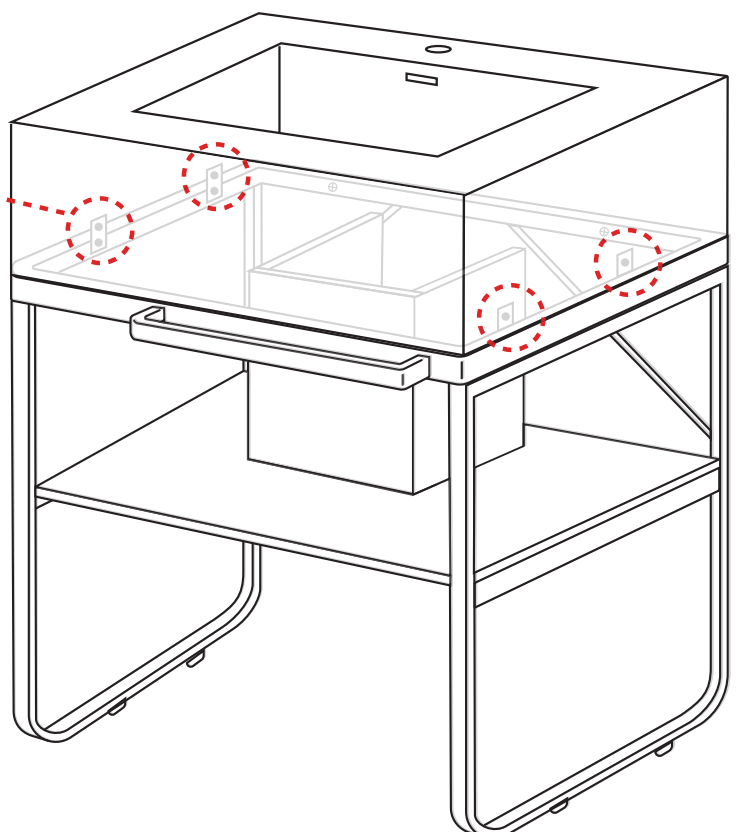
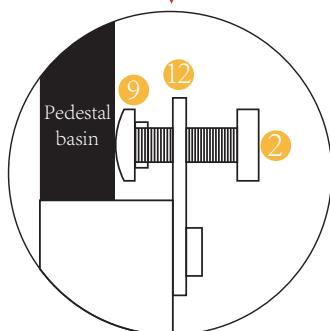
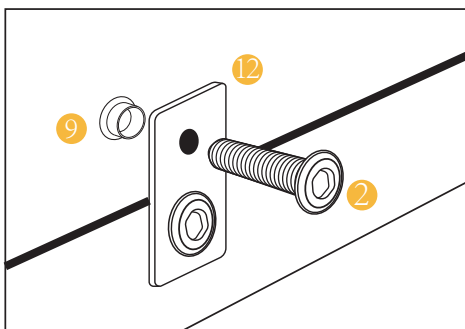
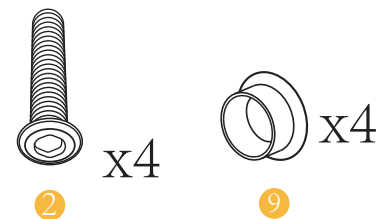

LIMITED WARRANTY COVERAGE

1 YEARS LIMITED WARRANTY

GETPRO products are made with quality materials and excellent craftsmanship to provide the customers a long-lasting product. In the case of any defects in materials or craftsmanship under regular use were inspected in the first one year of delivery, GETPRO will provide replacement parts at no charge, or at its option, replace any product or part of the product that is deemed defective, under normal installation, use, service and maintenance. This warranty applies only to the original purchaser. Proof of purchase will be required in the case of a claim.

GETPRO will, as its option

- (1) Repair or replace the defective part(s) or product(s) at no charge;
- (2) Issue a refund of the original purchase price of the product(s) (Valid within 30 days from the date of delivery);
- (3) Issue a credit to be applied toward the purchase of a new GETPRO product shipping/delivery charges may apply and are in GETPRO's sole discretion.

GETPRO recommends the installations to be made by a licensed, professional plumber. GETPRO will not be held responsible for any damage or product failure due to improper installation, misuse, or failure to use a licensed professional. GETPRO is not responsible for any removal or installation cost.

This limited warranty shall not apply to goods that have been subject to accident, negligence, improper installation, product abuse, product misuse, or use of cleaners containing abrasives, alcohol or other organic solvents, whether performed by a contractor, service company, or yourself, are excluded from this warranty.

GETPRO responsibility under this limited warranty is limited to only to replacement parts and no other costs.

GETPRO will not be responsible for labor charges and/or damage incurred by installation, repair, or replacement, nor for any indirect incidental or consequential damages, losses, injury, or costs of any nature relating to this product.

Except as provided by law, this limited warranty is instead of and excludes all other warranties, conditions, and guarantees, whether expressed or implied, statutory or otherwise, including without restriction those merchant ability of fitness for use.

RESPONSIBILITIES OF OTHERS

Inspecting the unit before installation is the responsibility of the installer or building contractor who acts on behalf of the user. They are responsible for ensuring the unit is free of defects or damage. Notices are placed on and in the unit and on the shipping carton advising the installer of this responsibility. In the event of a problem, the unit must not be installed.

GETPRO is not responsible for failures or damage that could have been discovered, repaired, or avoided by proper inspection and testing before installation.

Damage occurring in transit is the responsibility of the carrier. The user or installer **MUST** open the crate and inspect the unit for damage when it's delivered. If damage is discovered, it must be reported immediately to the seller and the carrier in writing, and an inspection requested. Failure of the carrier to respond should be reported to the seller and the carrier. Your freight claims should be filed promptly thereafter.

LIMITATIONS AND EXCLUSIONS

This warranty does not cover instances of negligence, misuse, abuse, improper installation, carelessness, accident, hard water or mineral deposits, exposure to corrosive materials, misapplication, damages caused by improper maintenance, alteration of the product, or failure to follow care or installation instructions enclosed with your product.

This warranty is void if the GETPRO is subject to alteration, or if repairs are attempted by anyone other than an authorized agent of GETPRO. This warranty does not extend to plumbing or components installed by dealers, installers or by any party other GETPRO.

GETPRO will not be liable for loss of use of the GETPRO inconvenience, or any other incidental or consequential costs, expenses, or damages. Please note that some states do not allow the exclusion or limitation of incidental damages.

DISCLAIMER

Except as expressly provided, there shall be no warranty or obligation, express or implied, oral or statutory. No dealer or other person has the authority to make any warranties or representations concerning GETPRO or its products. In no event shall GETPRO be held responsible for any such warranties or representations.

WARRANTY SERVICE

NOTE: When requesting a warranty, be sure to have the following:

- Copy of original invoice
- Date of installation
- Description and pictures of the defect
- Model number or description of the model

To obtain warranty service and replacement parts, please contact GETPRO Customer Service. GETPRO will determine whether to repair or replace your product, issue a refund, or issue a credit.

WARNING: Content may contain sharp and other possibly harmful pieces and may cause hazard to children and adults, GETPRO is not responsible in any way for personal damage.

CARE & MAINTACE

Solid surface countertop are made from a mixture of acrylic, polyester resins, and natural minerals, making them highly durable and resistant to scratches, stains, and impact damage.

1.Regular Cleaning:

Clean the countertop regularly with a mild, non-abrasive cleaner and a soft cloth or sponge. Avoid harsh chemicals or abrasive cleaners that can damage the glossy surface.

2.Avoid Scratches:

Use gentle cleaning tools and avoid abrasive scrubbers to prevent scratches on the glossy surface. Be cautious when placing objects on the countertop surface to avoid damage.

3.Stain Removal:

For stubborn stains, use a mixture of baking soda and water or a mild abrasive cleaner specifically designed for solid surface materials. Gently scrub the stained area and rinse thoroughly.

4.Prevent Build-Up:

Rinse the countertop after each use and wipe it dry with a soft cloth to prevent soap scum and mineral build-up. This helps to maintain the polish finish.

5.Avoid Harsh Chemicals:

Avoid using harsh chemicals, bleach, or abrasive cleaners on the countertop surface, as they can damage the polishing finish.

6.Sealant Maintenance:

Some solid surface countertops may require periodic resealing to maintain their appearance and protect the glossy surface. Follow the manufacturer's recommendations for sealing and maintenance.

7.Avoid Extreme Temperatures:

Avoid exposing the countertop to extreme temperatures, as sudden changes in temperature can damage the solid surface material. Use warm water for cleaning and avoid placing hot objects directly on the surface.

8.Regular Inspection:

Periodically inspect the countertop for any signs of damage, scratches, or wear. Address any issues promptly to prevent further damage.

HOME SERVICES

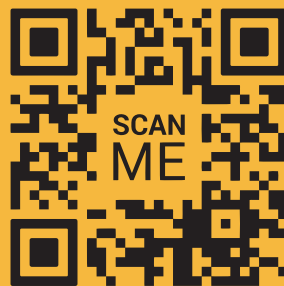

INSTALLATION VIDEO

Missing Part or Defective?

Please Contact the Customer Service Team

✉ service@getprohome.com

☎ 626 679 3588