

Assembly Instruction

Thank you for purchasing this quality product. Be sure to check all packing materials carefully for small parts, which may have come loose inside the carton during shipment. Identify and count all items and compare with the PARTS LIST and/or HARDWARE LIST shown below.

Caution: Please read the instructions thoroughly before assembly.

1. We recommend that you assemble this product with the assistance of another person; this will make the assembly easier, and will help eliminate damage to the product or injury to persons during assembly.
2. Please do not over tighten screws or bolts until the assembly is completed.
3. Please put all parts on a non-abrasive floor before assembly, and follow the assembly steps to assemble your newly purchased product correctly and efficiently.

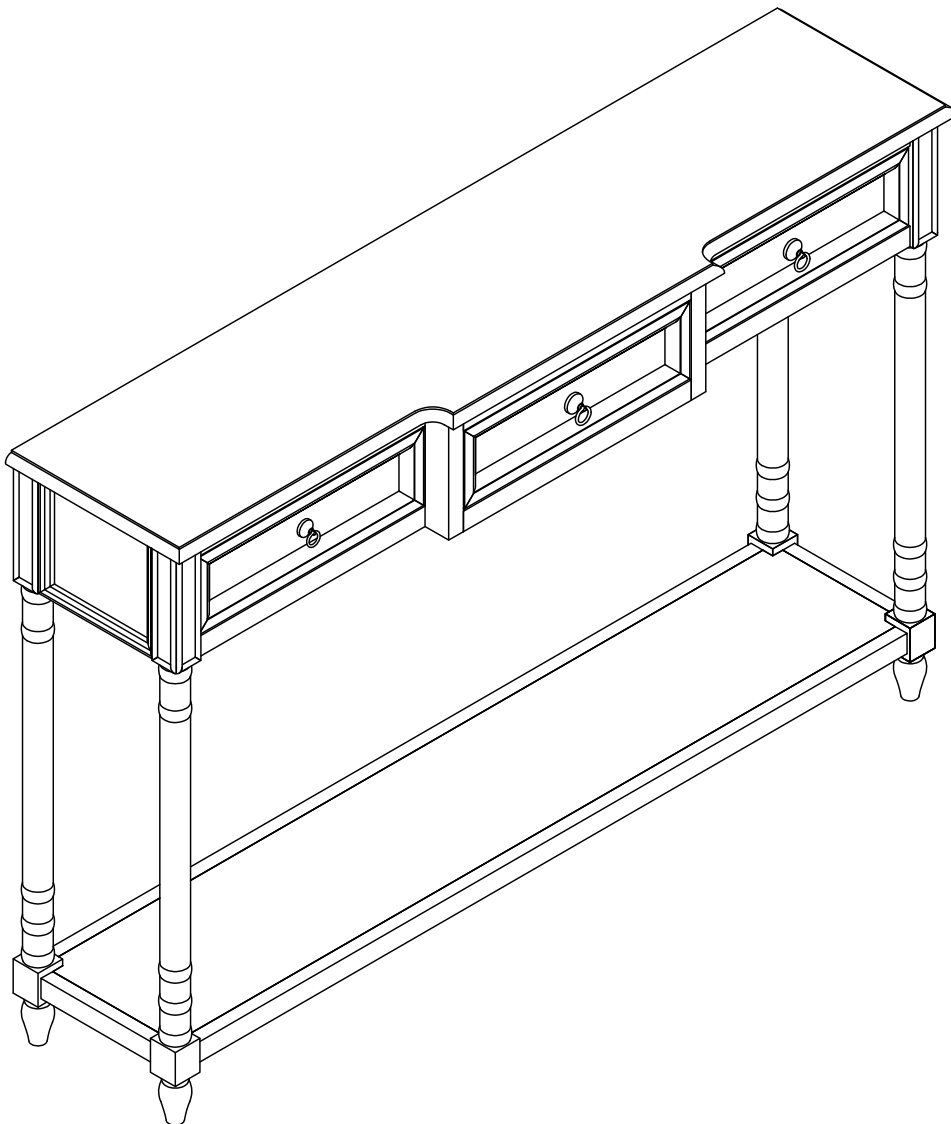





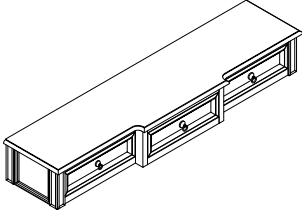
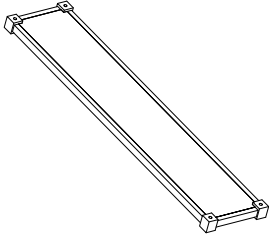

Assembly Instruction

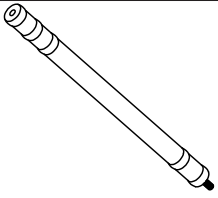
PART LISTS

NO	DESCRIPTION	SKETCH	Q'TY
A	Console Table		1PC
B	Shelf		1PC

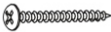
PART LISTS

NO	DESCRIPTION	SKETCH	Q'TY
C	Long Legs		4PCS
D	Short Legs		4PCS
①	Anti Tip Kit		2 sets
①.1	Plastic Anchor		2 PCS
①.2	Metal Bracket		4 PCS
①.3	Long screw M4 x 40		2 PCS
①.4	Short screw M4 x 15		2 PCS
①.5	Steel wire		2 PCS

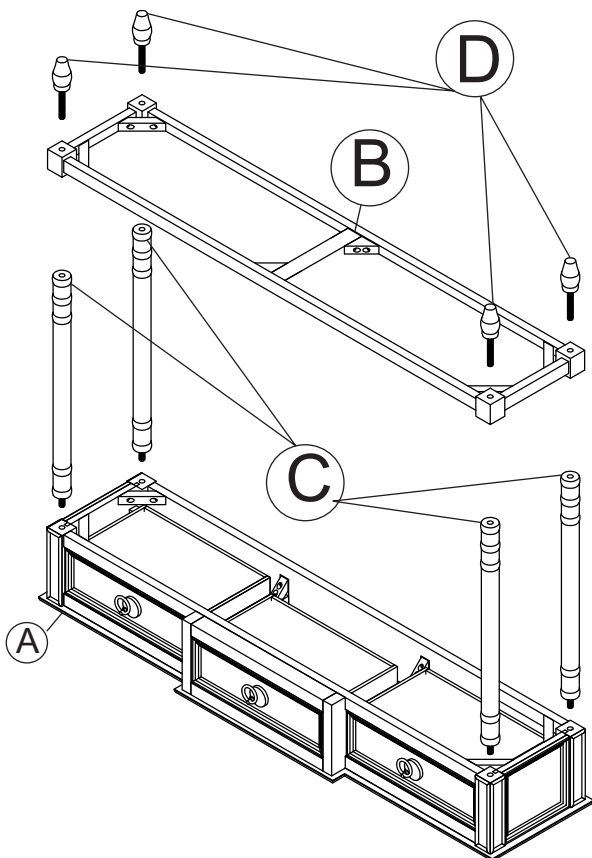

Assembly Instruction

STEP 1

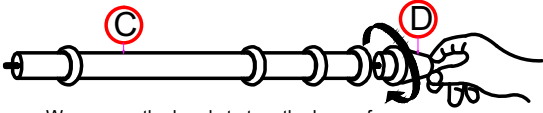

We are use the hands to turn the base of the legs cabinet counterclockwise

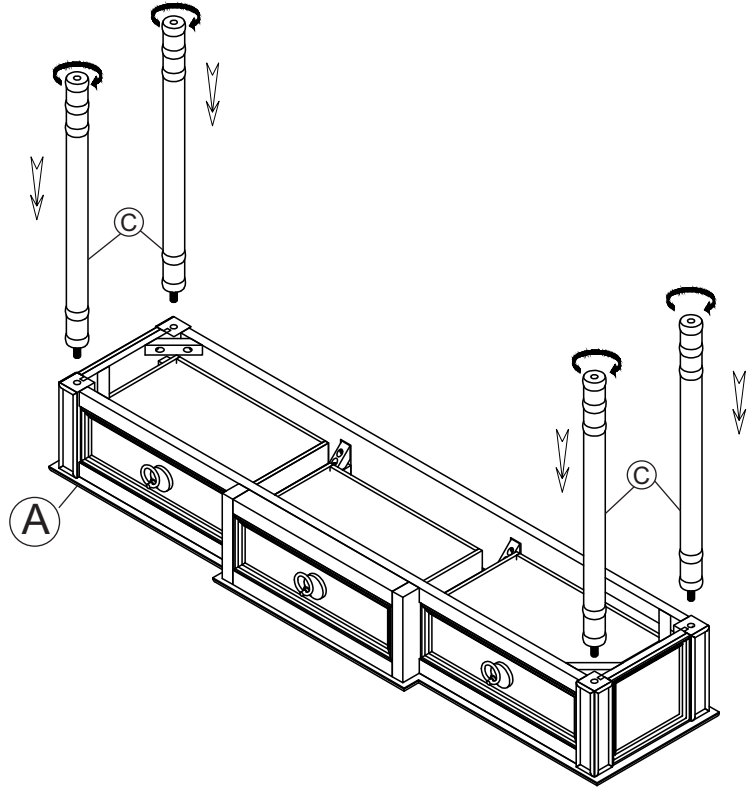

STEP 2

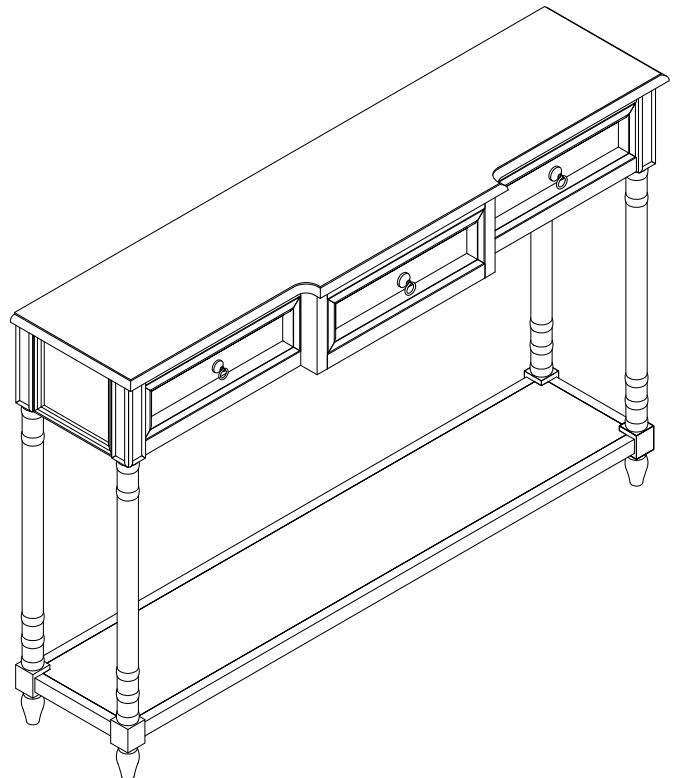
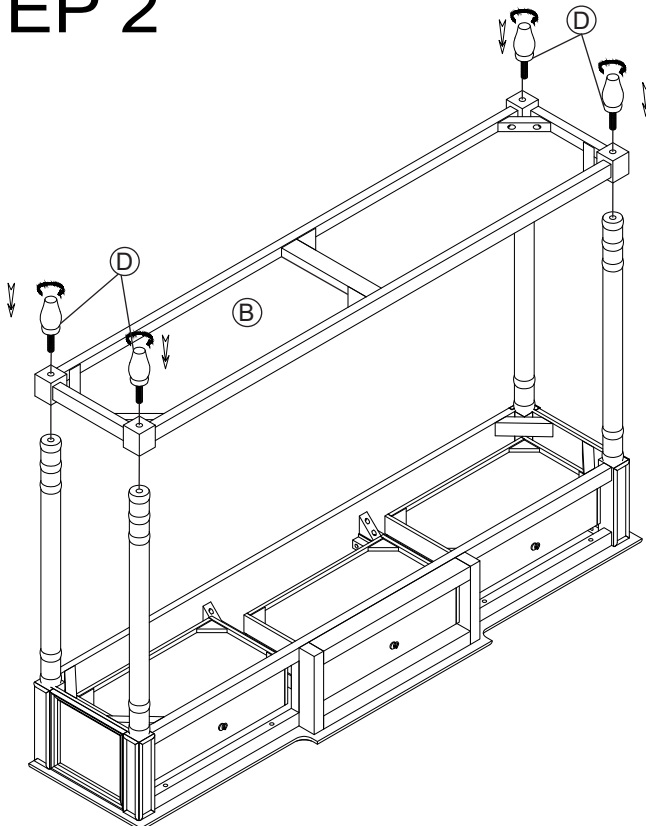



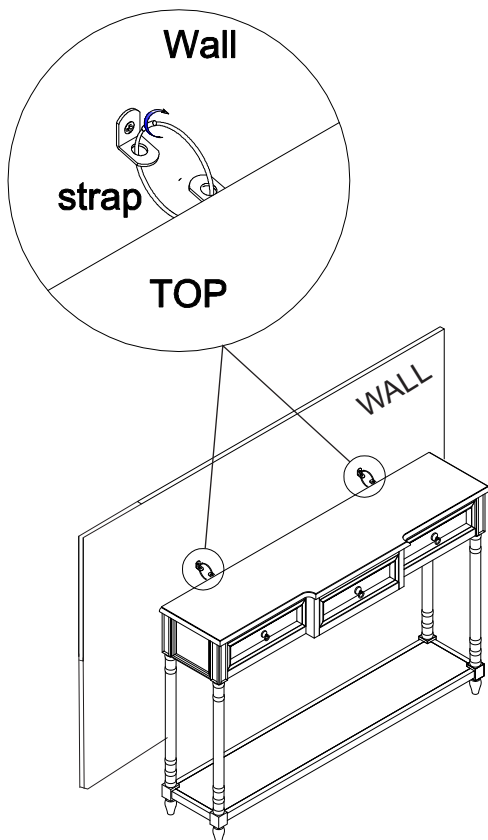
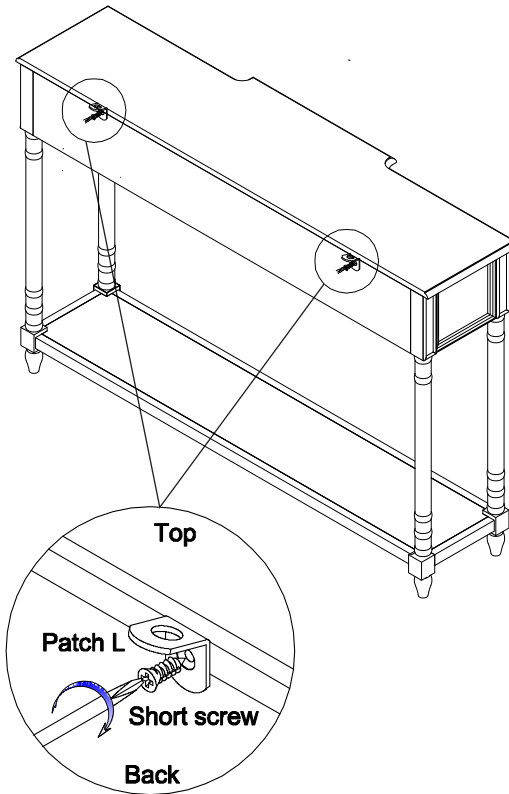
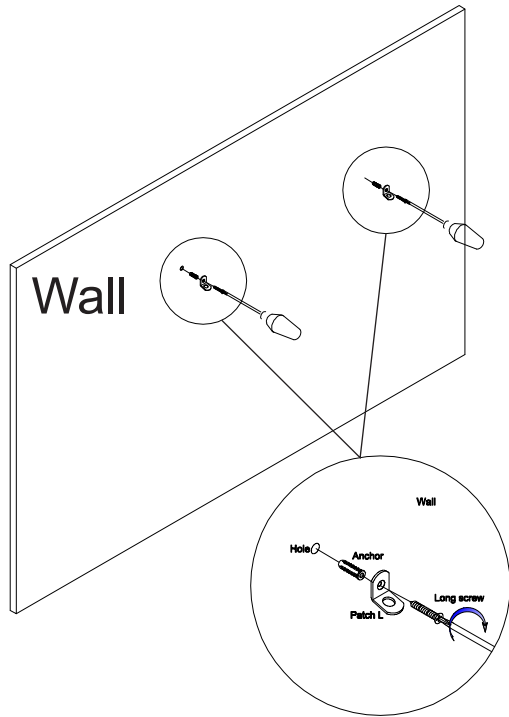

Assembly Instruction

STEP 3

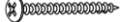

ANTI-PARKING KIT 2 SETS

				
2 pcs	4 pcs	M4 x 40 2 pcs	M4 x 15 2 pcs	2 pcs