

# ASSEMBLY INSTRUCTIONS

## TEAK 5' BENCH

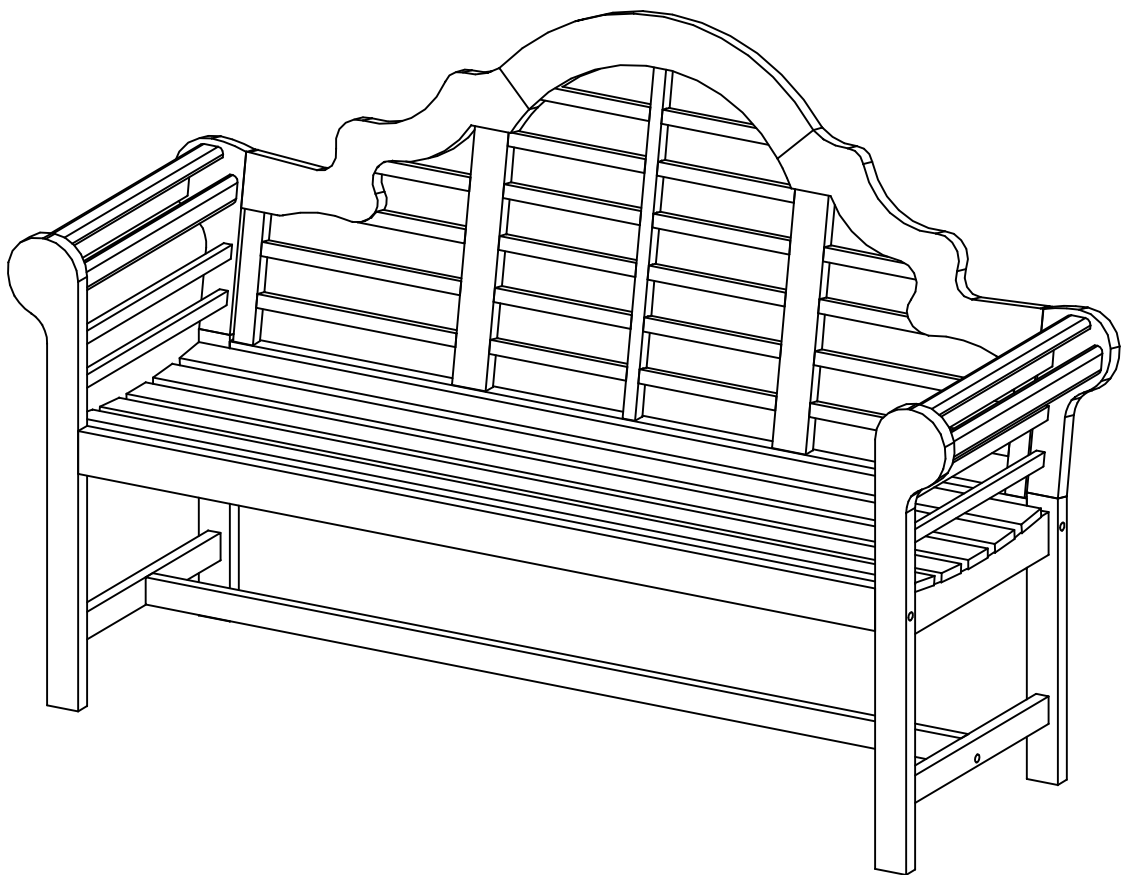

### CUSTOMER SERVICE INFORMATION

Please email us for assembly tips, report damage, or request parts.  
For faster response, please write down item number, code for missing parts,  
attach the purchase receipt and picture of damaged parts.

## GENERAL INFORMATION & TIPS

1. Please read the assembly instructions prior to assembling the Bench.
2. To avoid damage, assemble the bench on a non-abrasive surface such as carpet.
3. Make sure all bolts and screws tightly fastened before the bench is used.
4. This bench is not for commercial use.







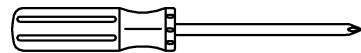

Please make sure you have all parts before beginning assembly. Please wait until all steps are completed before tightening bolts and screws.

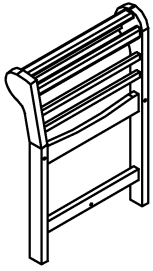
### TOOLS REQUIRED

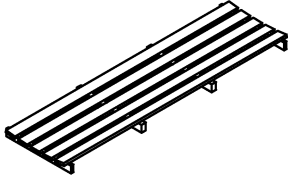
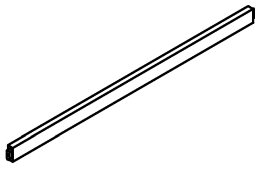
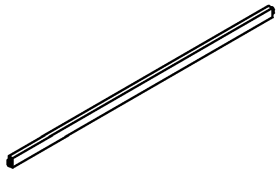
1. 8" Philips screwdriver (Not provided).  
- For tightening all bolts and screws.
  
2. Rubber Mallet (Not provided).  
- For tapping in the wooden caps.



## PARTS AND HARDWARE LIST

A1. Right side frame	A2. Left side frame	B. Back support	C. Seat
			
Qty : 1 Pc	Qty : 1 Pc	Qty : 1 Pc	Qty : 1 Pc
D. Apron	E. Cross bar	F. 2" Bolt	G. 1" Bolt
			
Qty : 1 Pc	Qty : 1 Pc	Qty : 4 Pcs + 1	Qty : 2 Pcs + 1
H. 1 1/4" Screw	I. 1" Screw	J. 3/4" Screw	K. Wooden cap
			
Qty : 4 Pcs + 1	Qty : 4 Pcs + 1	Qty : 2 Pcs + 1	Qty : 6 Pcs + 1

### STEP 1

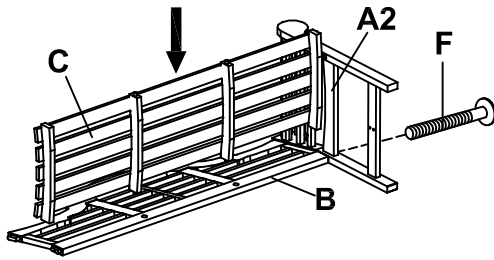

Attach the back support (B) left side frames (A2) and secure using 2" bolts (F) as shown.  
Put the seat (C) into predrilled holes of back support (B).

**\*\* DO NOT TIGHTEN BOLTS YET.**

### STEP 2

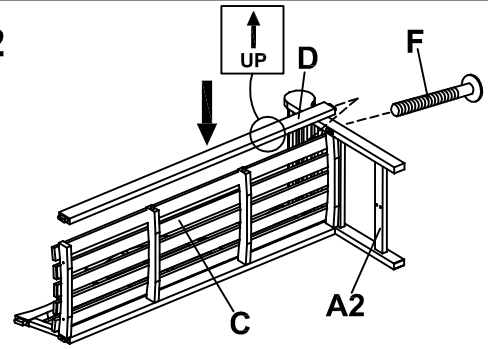

Attach apron (D) onto seat (C) and left side frame (A2) and secure using 2" bolt (F) as shown.

### STEP 3

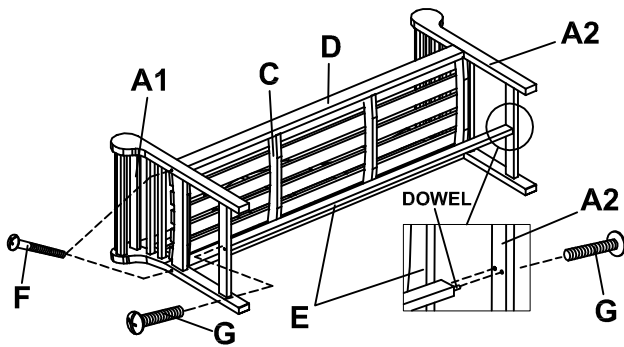

Attach right side frame (A1) into back support and apron and secure 2" bolts (F).  
Next, attach the cross bar (E) into side frames (A1 & A2) and secure using 1" bolts (G) as shown.

### STEP 4

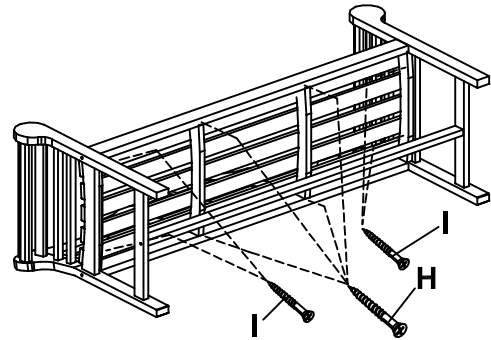

Secure the seat (C) using 1 1/4" screws (H) into back support and apron and 1" screws (I) into side frames.  
Make sure all parts are correctly connected and tighten all bolts completely using screwdriver.

### STEP 5

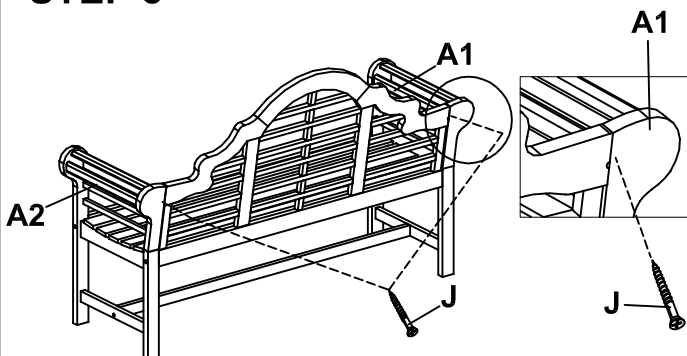

Upright the bench.  
Insert 3/4" screws (J) into predrilled holes of side frames (A1 & A2) as diagram shown.  
Tighten the screws using phillips screwdriver.

### STEP 6

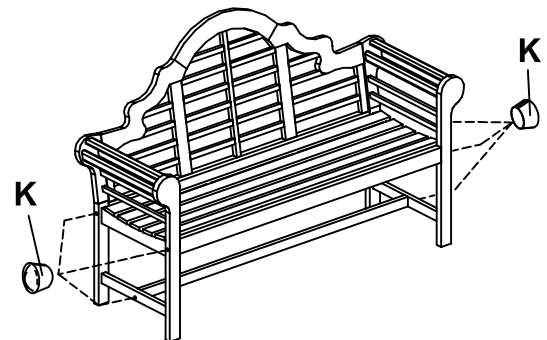

- Tapping in the wooden caps (K) to cover bolts head using rubber mallet.

**ASSEMBLY COMPLETE!**

## **MAINTENANCE**

Due to teak wood's natural characteristics, wood color and grain variations may be present. This is a symbol of the originality of each unit and gives each finished piece a distinctive look and inherent charm.

### **Care Instruction :**

Teak wood, when left bare and unsanded, will naturally fade to a silver-gray color. This silver-gray color transformation does not in any way affect the durability of the furniture.

To maintain the smooth finish and golden brown color of your teak furniture, you will need to sand the furniture regularly. To prolong the period of time needed between sanding, teak oil may also be applied.

If you choose to apply teak oil, apply every 6 months, or follow the teak oil container directions. Again, if you choose to maintain the smooth brown finish of your teak furniture, this method requires some regular maintenance, such as sanding and reapplication of teak oil. Teak oil, along with sanding, will help maintain the golden brown color.

### **Staining :**

Please note, once you stain your teak, it will not return to the natural golden brown or weathered silver-gray color without sanding off the stain. Staining is intended to be permanent. If you choose to stain your furniture after it has turned silver-gray, you must first sand it before applying the stain.

**Do not leave your teak wood furniture in puddles of water or on wet ground.**

**Cover your teak wood furniture during winter months or move into covered storage, if in wet climates.**

**The manufacturer supports protection of the world's forest resources and is diligent in sourcing legally harvested wood.**

Thank you  
The manufacturer

# 1 year Limited Warranty

The furniture is warranted to be free from defects in material and workmanship of the original product when purchased from one of our authorized dealers. If a product fails and is under the terms of our limited warranty, the item will be replaced, usually for a small fee. In the case of discontinued models, an item of similar quality and style will be offered to the customer.

- 1 year limited frame warranty  
Frames are warranted to be free from defects in material and workmanship. Fading or discoloring caused by putting the product under sunlight or rain is not covered by this limited warranty. Damage to the frame due to improper assembly or exposure to water and sub-freezing temperatures is not covered. ( Do NOT allow water to accumulate inside frame )
- Finish  
The finish is warranted against peeling, cracking, or blistering for a period of 1 year, provided the unit has not been scratched or abraded. Scratches and chips resulting from normal wear and use are not covered. Peeling resulting from exposure to elements is not covered.

Warranty Exclusions : Furniture used for commercial, contractor or any non-residential purposes, clearance items, display models or items purchased “as is”, freight damage, furniture damaged by acts of nature, vandalism, fire, abuse, lack of proper care and maintenance, or improper assembly, straps and fabric against fading or discoloration from exposure to elements, oil spills, fluids or chemicals; glass against breakage; hardware against corrosion or rusting; buckling or splitting of tubing resulting from exposure to water and freezing temperatures. Also excluded: loss of use or time, inconvenience, money, travel, packaging or any other consequential or incidental damages. In no event shall the manufacturer's responsibility exceed the value of the replacement product.

Warranty is to the original purchaser when items are purchased from one of our authorized retailers and is not transferable. Should replacement of the warranty item be unavailable, the manufacturer reserves the right to substitute items of our choice that are of similar style and quality. For quality control purposes and verification, we need documents in support of your claim :

- Packing slip / Invoice
- Additional documents (Photos or video) of damaged/ defected/ missing part
- Item number and part code (can be found on assembly instruction)

Note :

To expedite the handling of your claim, please include the above mentioned documents as your claim **WILL NOT BE PROCESSED** until properly supported. **Retain all damaged goods until the claim is concluded.**

The terms of this warranty are subject to change without notice.