

# Assembly Instruction



OFFICE CHAIR

# ASSEMBLY INSTRUCTIONS

## ASSEMBLY TIPS:

1. Remove hardware from box and sort by size.
2. Please check to see that all hardware and parts are present prior to start of assembly.
3. Please follow attached instructions in the same sequence as numbered to assure fast & easy assembly.



### WARNING!





1. Don't attempt to repair or modify parts that are broken or defective. Please contact the store immediately.
2. This product is for home use only and not intended for commercial establishments.





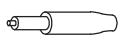
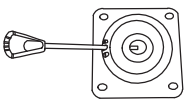

**ASSEMBLY TIME**

**10 MINUTES**

## PARTS IDENTIFICATION

A	BASE		1PC
B	LEG		5PCS
C	CASTER		5PCS
D	GAS CYLINDER		1PC
E	ADJUSTING PLATE		1PC
F	SEAT AND BACK		1PC

## Z HARDWARE IDENTIFICATION

1	ALLEN WRENCH (M6)		1PC
2	BOLT (M6 x 20mm)		4PCS
3	BOLT (M6 x 10mm)		5PCS
4	WASHER (φ 6 x φ 18mm)		4PCS

# ASSEMBLY INSTRUCTIONS

STEP 1

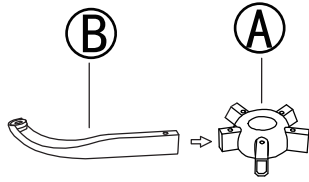

STEP 2

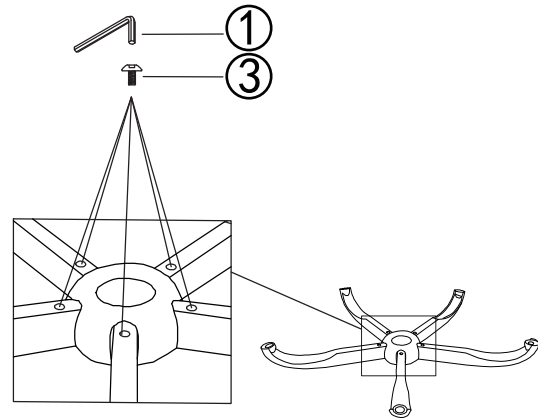

STEP 3

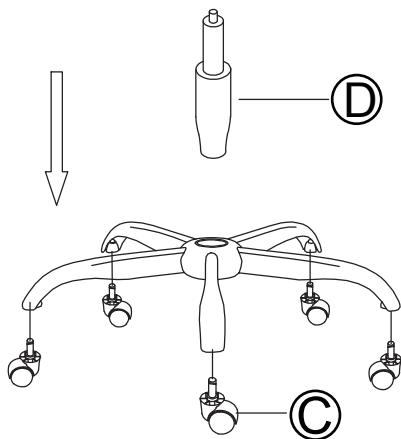

STEP 4

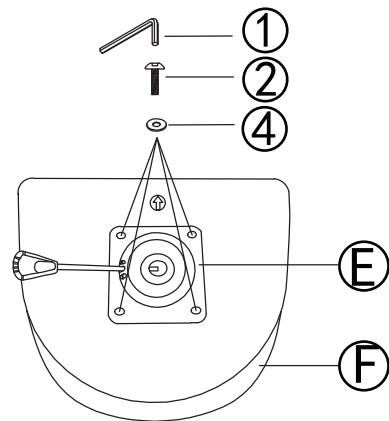

STEP 5

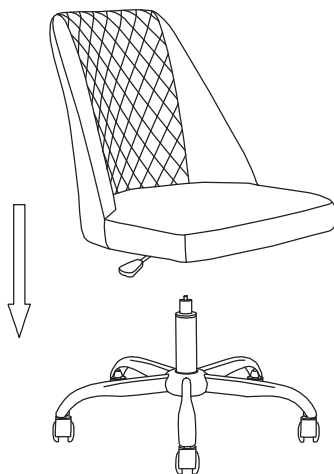

STEP 6



# ASSEMBLY INSTRUCTIONS

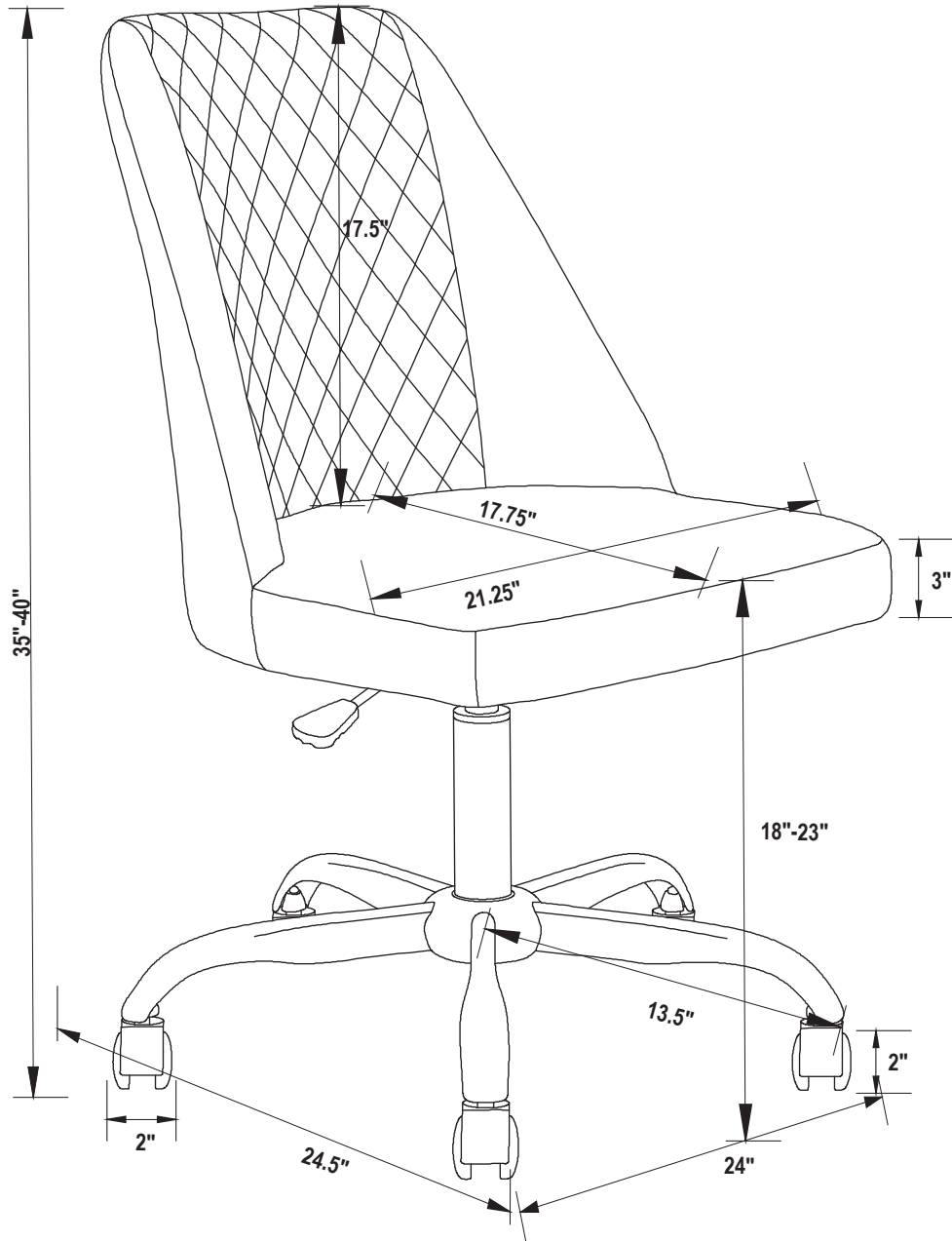

**Note :** Dimension tolerance  $\pm 5\%$