

Kitchen Cart

IMPORTANT NOTE

Carefully remove all the parts from the carton and put them individually on a soft cloth to prevent scratches or other damages occurring to the wood parts.

We have taken great care in the design of this product and request that you carefully and strictly follow our assembly instructions to ensure a completed product as it was designed.



Part List

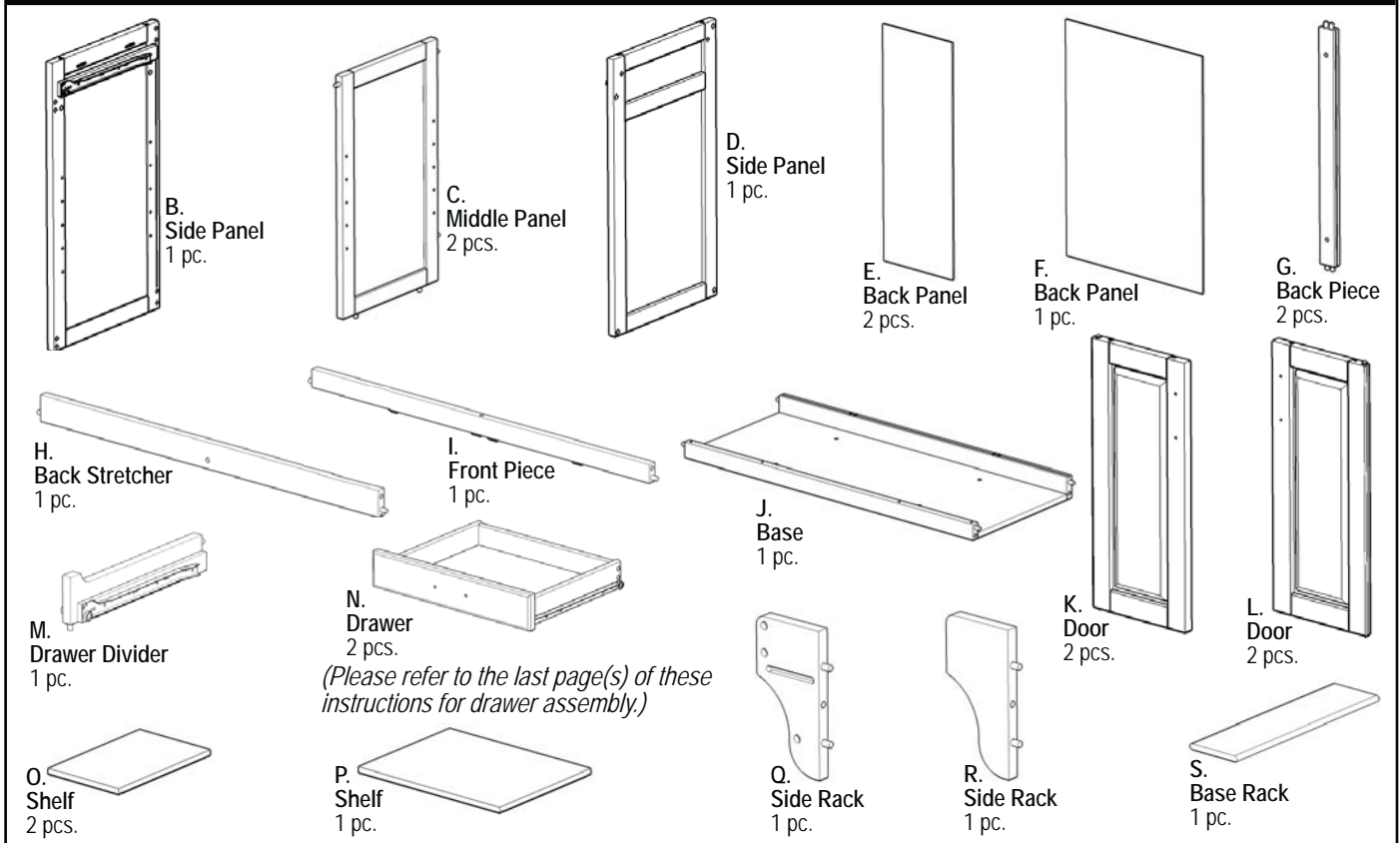

Hardware List

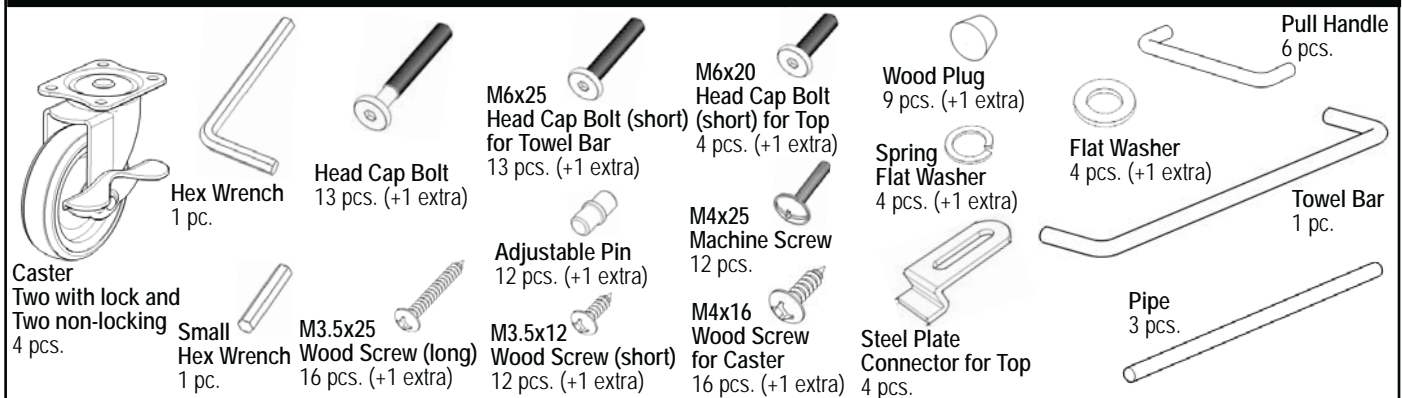

Tools required for assembly : Phillips screwdriver

IMPORTANT

- * Do not tighten up all the screws and bolts until each part is properly assembled.
- * You should keep Hex Wrench in a safe place as you may need to tighten up the Head Cap Bolts in the future.
- * Use a soft cloth between these parts and the floor.

STEP 1

Attach 4X Casters to Base (J) with Wood Screws for Caster, with the Locking Casters at the front as indicated by 'Arrow' sticker. (see Figure 1)

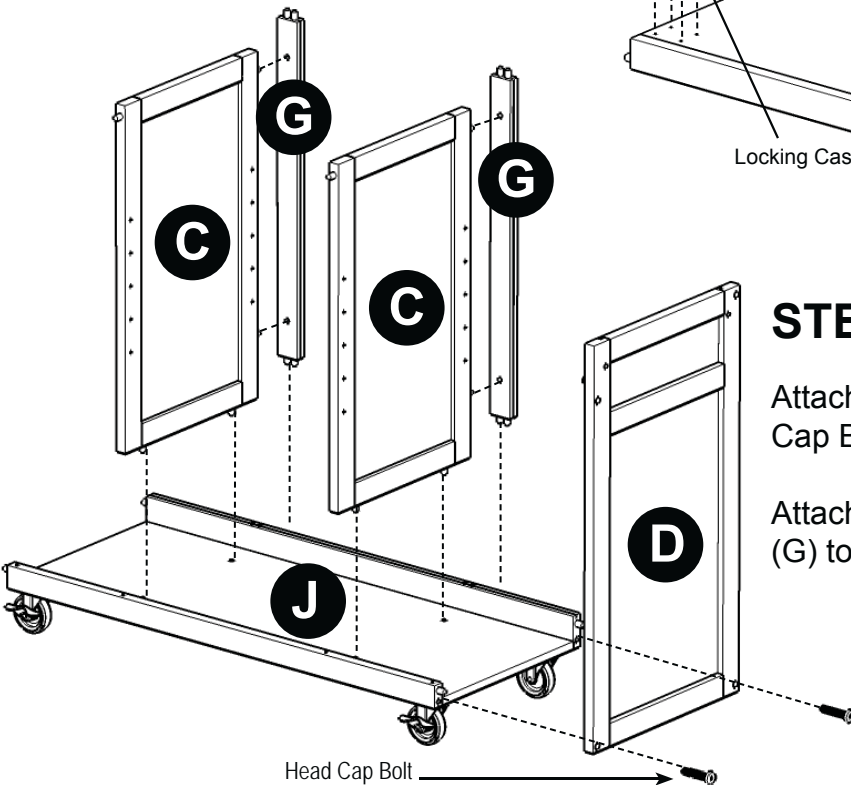
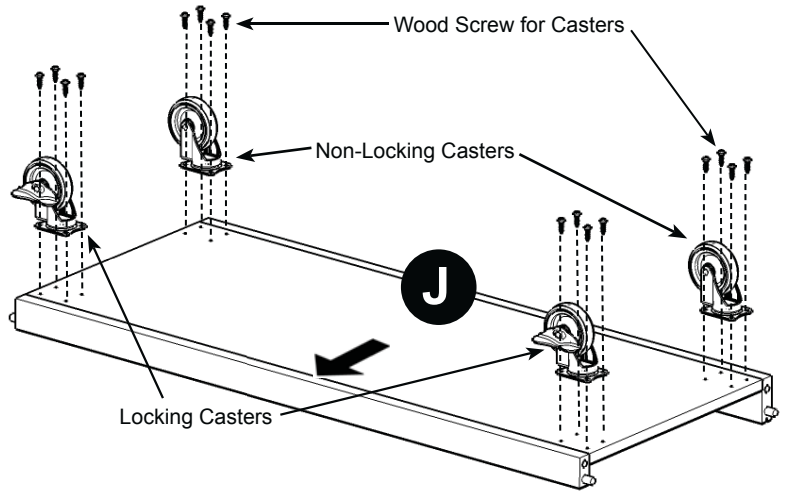

STEP 2

Attach Side Panel (D) to the unit with Head Cap Bolts. (see Figure 2)

Attach Middle Panels (C) and Back Pieces (G) to unit.

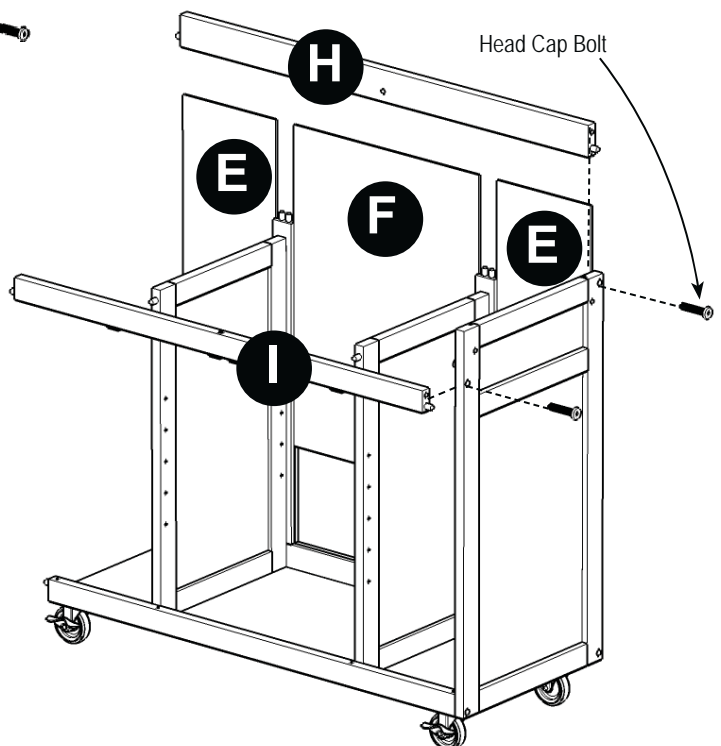

STEP 3

Slide Back Panels (E) and (F) into the unit.

Attach Back Stretcher (H) and Front Piece (I) to the unit with Head Cap Bolts.

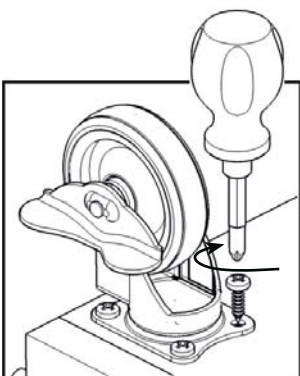

Figure 1

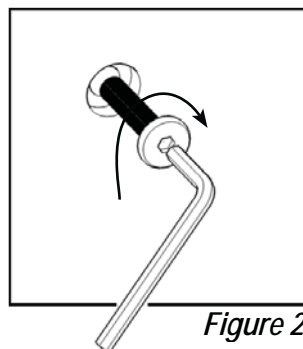
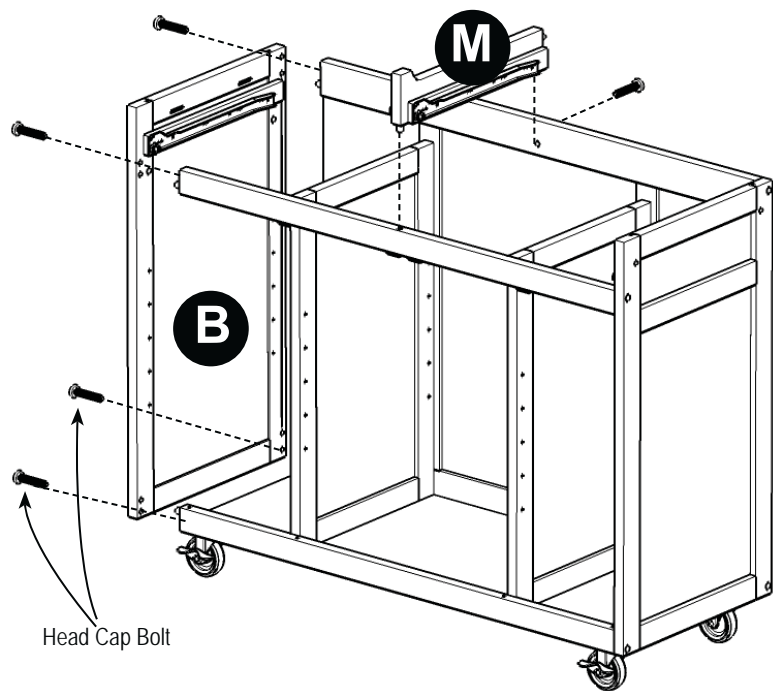

Figure 2



STEP 4

Attach Side Panel (B) and Divider (M) to the unit with Head Cap Bolts.

STEP 5

Attach Side Rack (Q) to the unit with Head Cap Bolt.

Slide Base Rack (S) and Pipes into Side Rack (R).

Attach Side Rack (R) to unit with Head Cap Bolt.

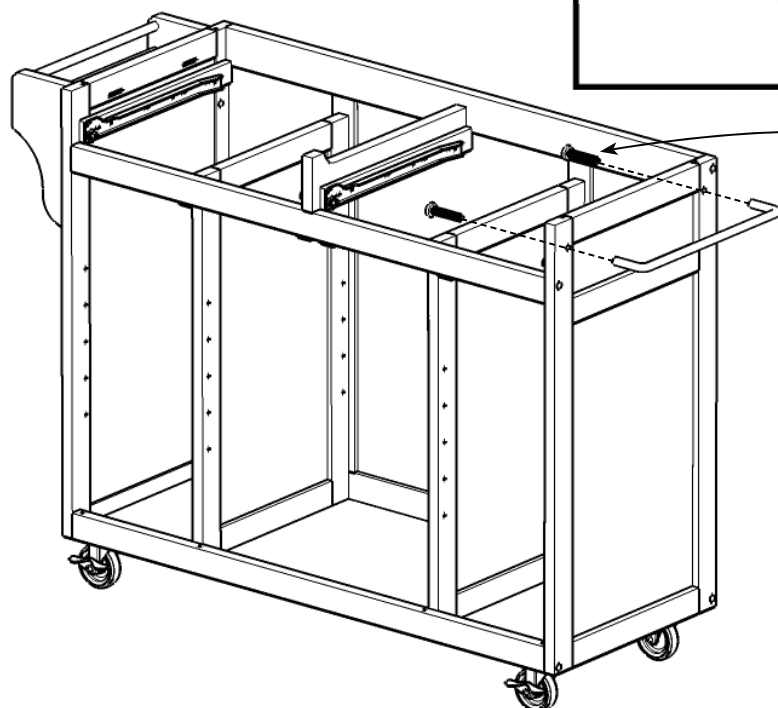
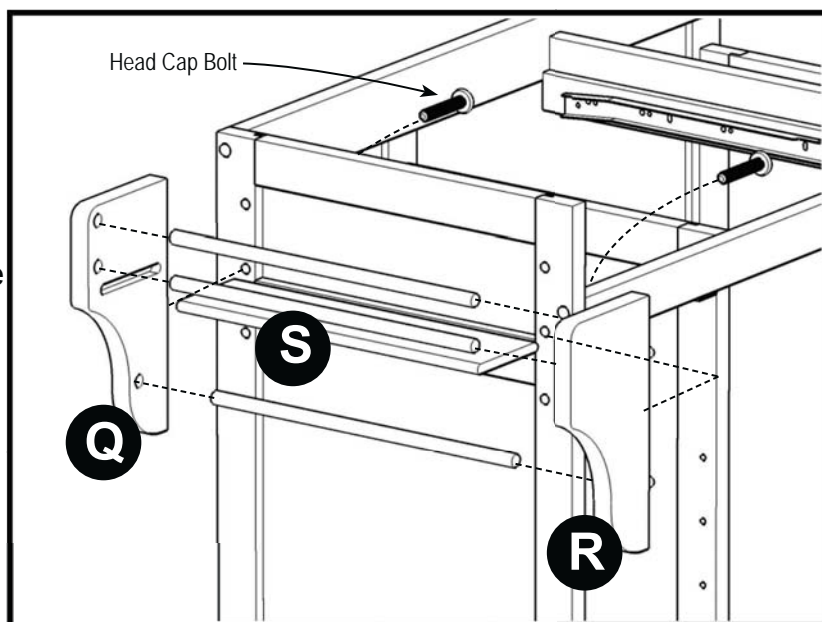

STEP 6

Attach Towel Bar to the unit with Head Cap Bolts (short) for Towel Bar.

STEP 7

Insert Adjustable Pins into side panels and middle panels at the desired level and slide Shelves (O) and (P) into place.

Assemble Pull Handles to Doors (K) and (L) with Machine Screws. (see Figure 3)

Attach Doors (K) and (L) by inserting the lower Spring Pin into the hole until it clicks (see figure 4) and then do the same for the upper Spring Pin.

Slide Drawers (N) into place.

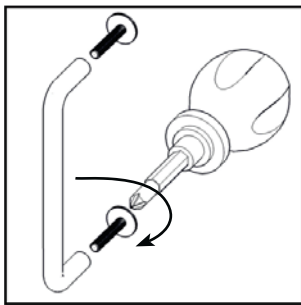
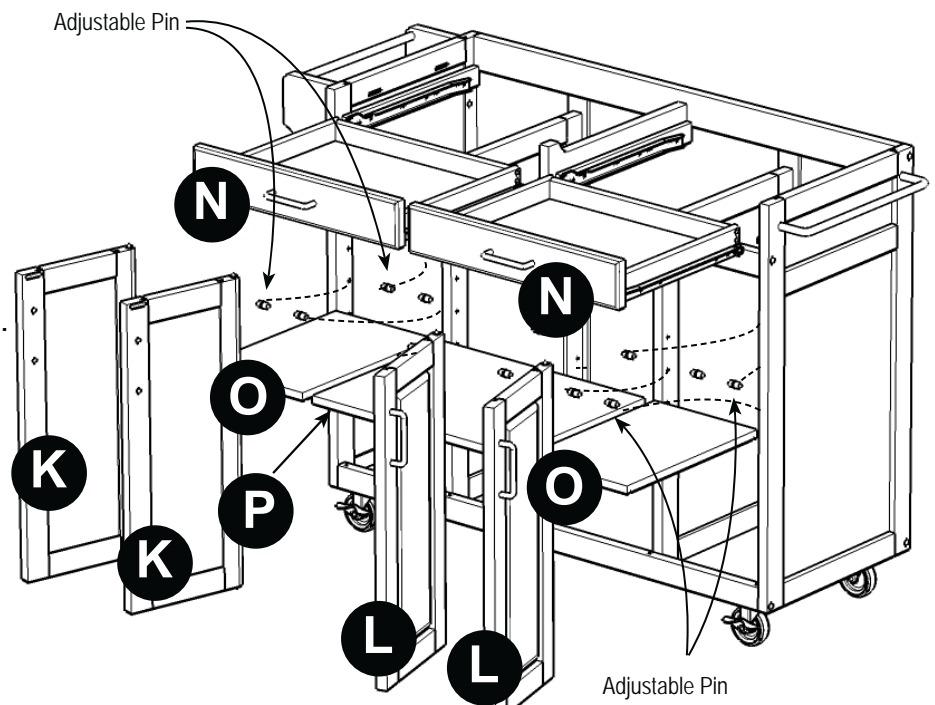

Figure 3

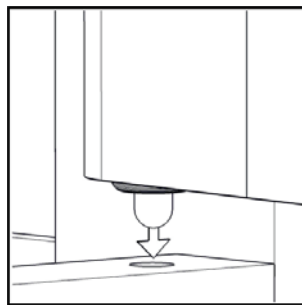

Figure 4

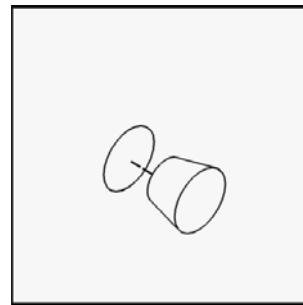
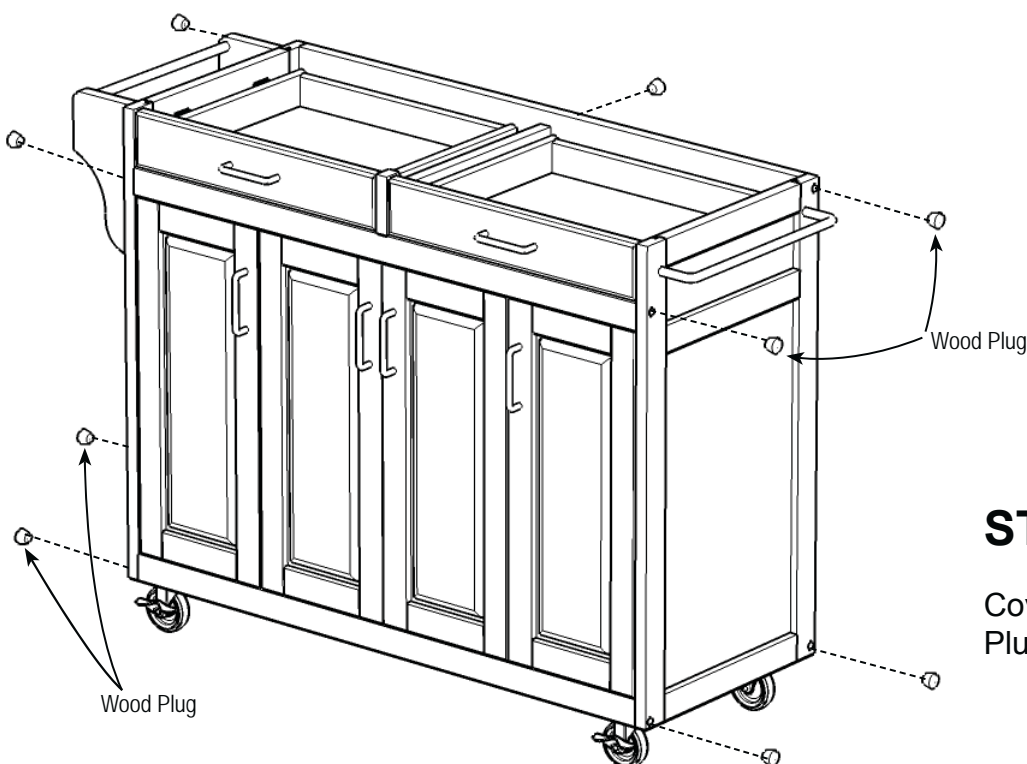

Figure 5



STEP 8

Cover all holes with Wood Plugs. (see Figure 5)

Drawer (N)

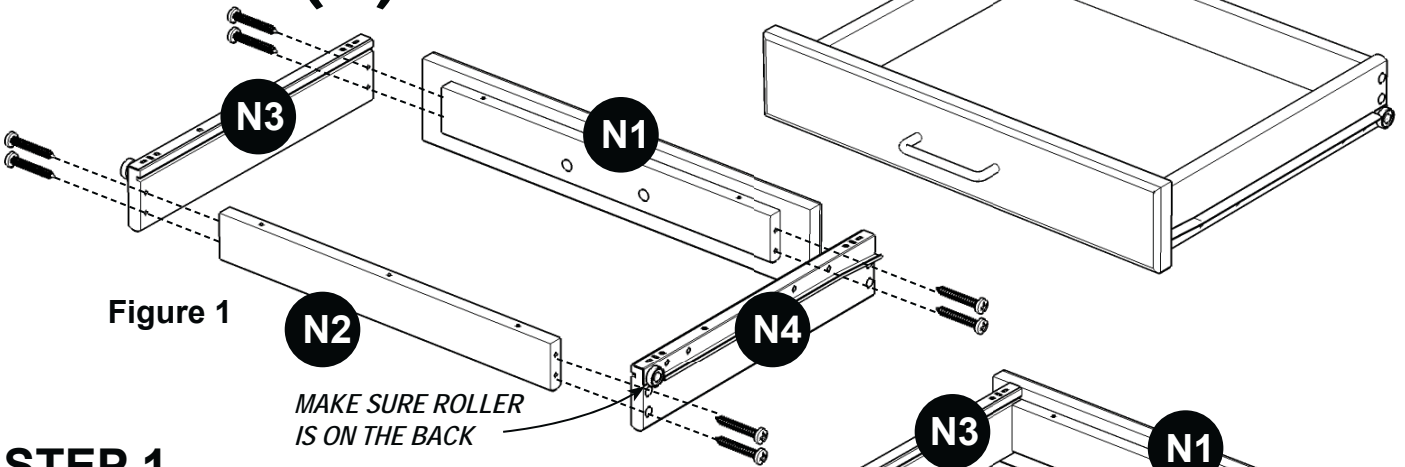

Figure 1

STEP 1

Attach N1 to N3 and N4, using a Phillips screwdriver and long wood screws (4X), tighten halfway.

Attach N2 to N3 and N4 using long wood screws (4X), tighten halfway. (see Figure 1)

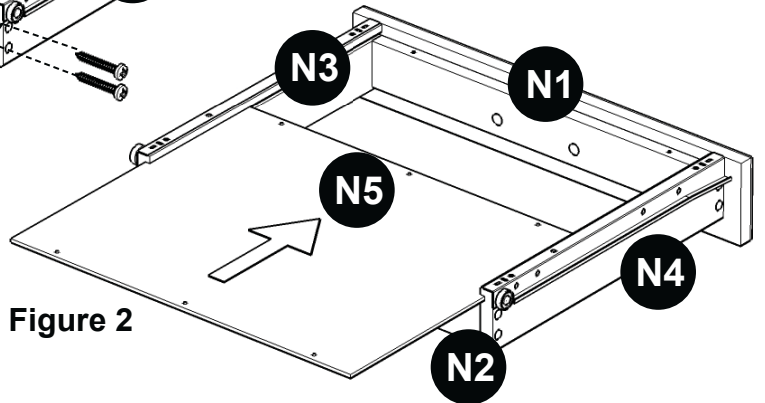

Figure 2

STEP 2

Slide N5 into the grooves in N3 and N4. Push N5 all the way forward so it meets N1. (see Figure 2)

Figure 4

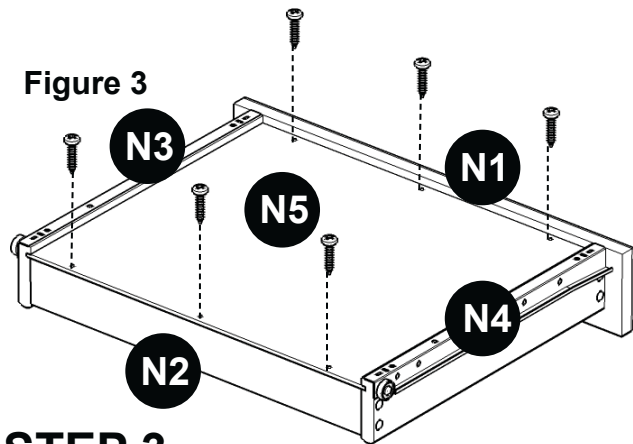

Figure 3

STEP 3

Insert short wood screws (6X) into the pre-drilled holes in N5 and tighten. (see Figure 3)

STEP 4

Assemble Pull Handle with machine screws. (see Figure 4)

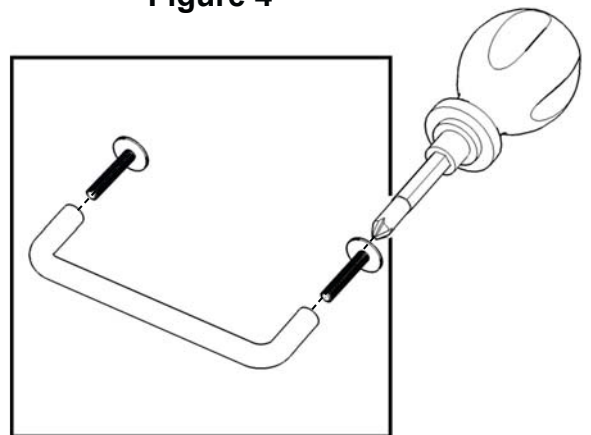

Tighten all screws used in drawer assembly.

Part List

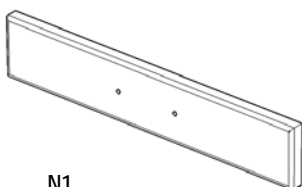

N1.
Front Part
2 pcs.

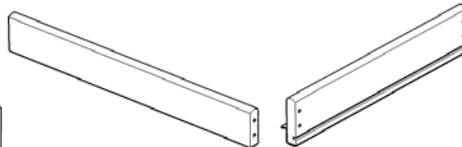

N2.
Back Part
2 pcs.

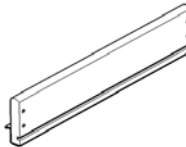

N3.
Side Part
2 pcs.

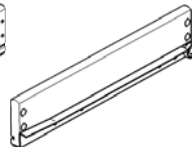

N4.
Side Part
2 pcs.

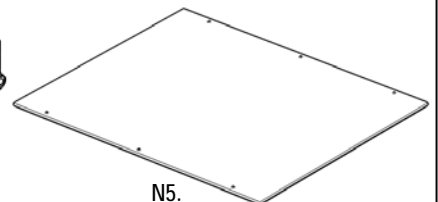

N5.
Base Part
2 pcs.