

# Office Chair



Instruction Manual

Follow the instructions for the assembly,  
daily care and after-sales service!

---

# Notes



1. Follow the instructions for the assembly.
2. Do not tighten screws with Allan key until you have put together the whole set.  
That way if you make a mistake you can quickly remove a screw.
3. Use soft dry cloth to wipe the dirt from the chair, or use a cloth which is moistened by clear water to clean. When there are stubborn stain on the surface, use warm clear water to moisten the cloth and then use the wet cloth to wipe the dirt.
4. Do not use Alcohol, gasoline or any organic solvent for cleaning.
5. Do not put the chair in a humid or sun-exposed environment, a dry, ventilated room is recommended to avoid direct sunlight, so as to prevent premature oxidation and ensure the chair's safety of use and service life.
6. Do not let kids jump or play on it to prevent the injuries of kids and unpredictable damage to the chair.

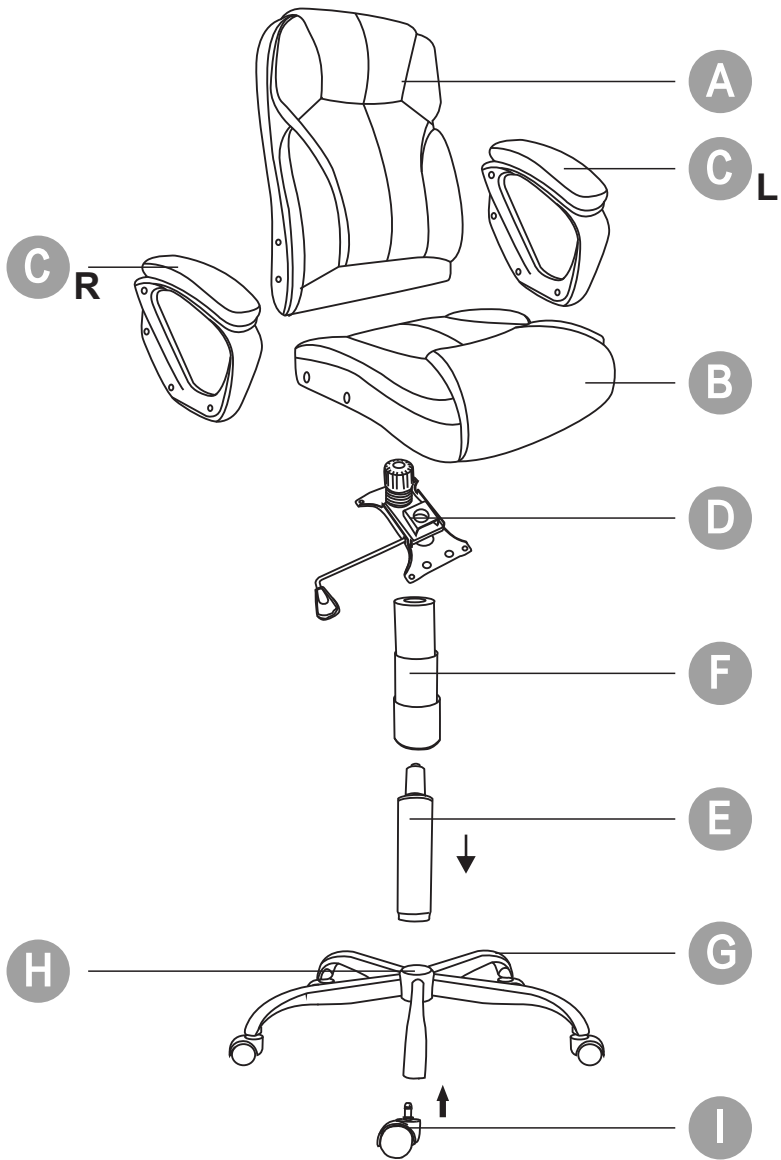

# Parts List



A

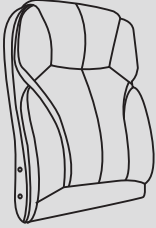

B

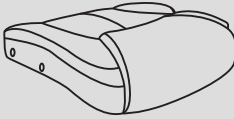

C

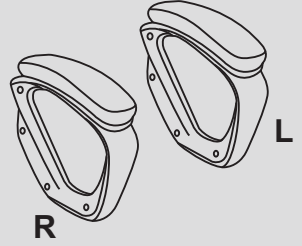

D

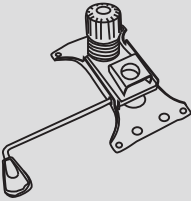

E

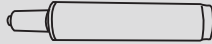

F

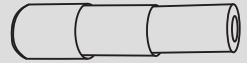

G

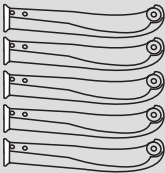

H

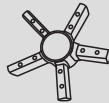

I



# Hardware List



1



M6 × 20

2

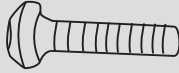

M8 × 30

3



M6 × 16

4

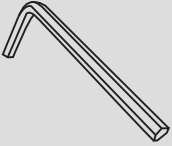



## Step 1

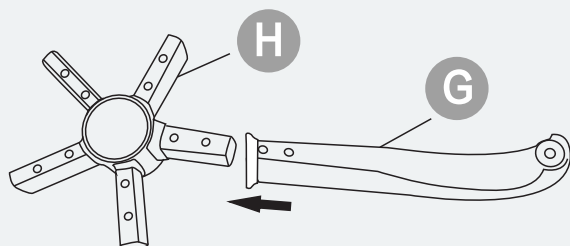

## Step 2

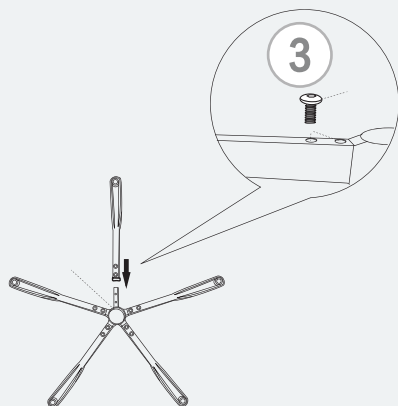



### Step 3

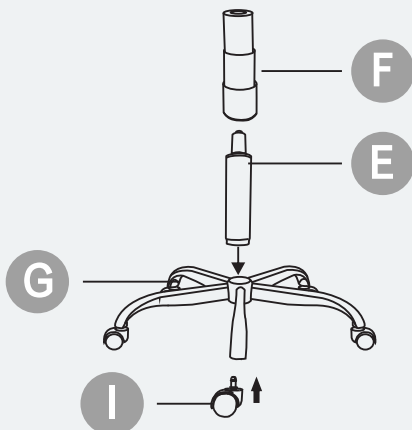

### Step 4

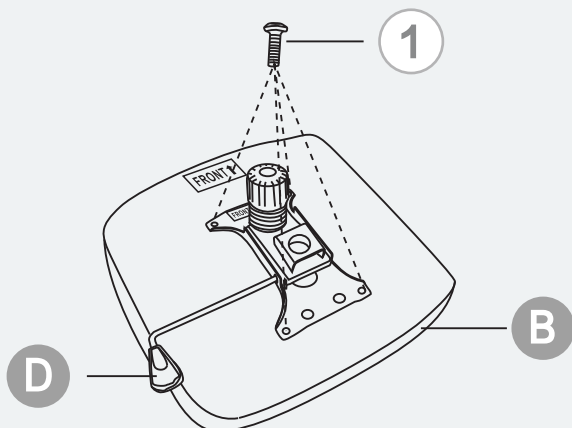



## Step 5

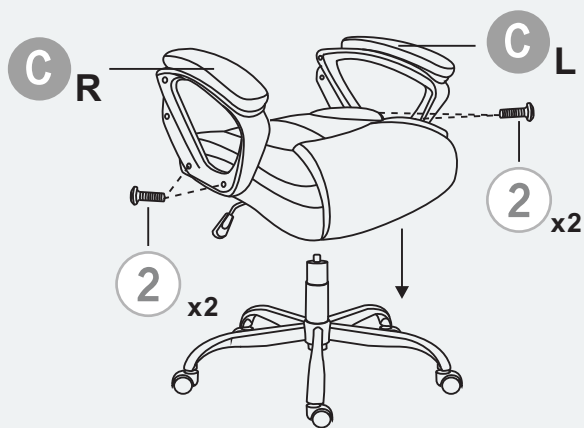

## Step 6





## Step 7



## Step 8



## Warning

Seller is responsible for the product-related issues occurred upon receipt, but will not be responsible for the personal injury, property damage or loss resulting from the incorrect assembly, improper use, inadequate maintenance or neglect of this product.