

SMART-TECH CLICK SYSTEM

Sideboard

Assembly Instructions

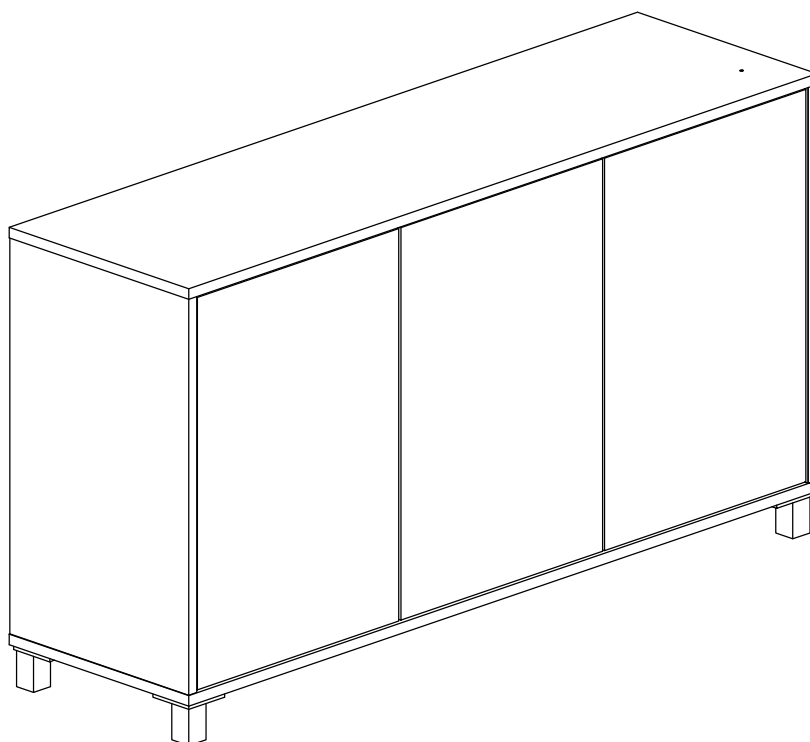

NOTE

We highly recommend watching the quick help & set up guide video first before assembling. Simply place a smart phone camera over the QR code for a quick link to the video.















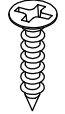

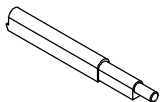
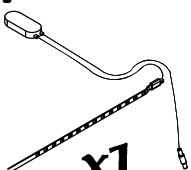
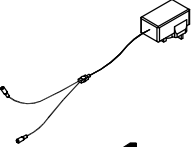

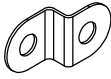
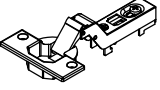
To watch assembly video :
www.frankolsenfurniture.co.uk

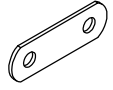
Download the **Frank Olsen Smart app** from :
Google Play store or Apple store

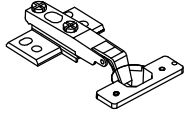

HARDWARE

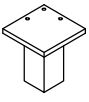
0 5 10 15 20 25 30 35 40 45 50 55 60 65 70 75 80 85 90 95 100 105 110 mm

A M3*12  x2	B M3.5*14  x28	C M3.5*18  x20	D M3.5*25  x4	E  x3	F  x1	G  x1
H  x2	I  x2	J  x4	K  x1	L  x3	M  x4	N  x2
O  x2	P  x12	Q  x2	R  x4	15  x4	16  x2	

Tools Required-Not Supplied

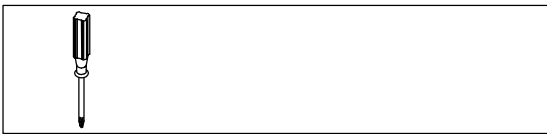

PARTS

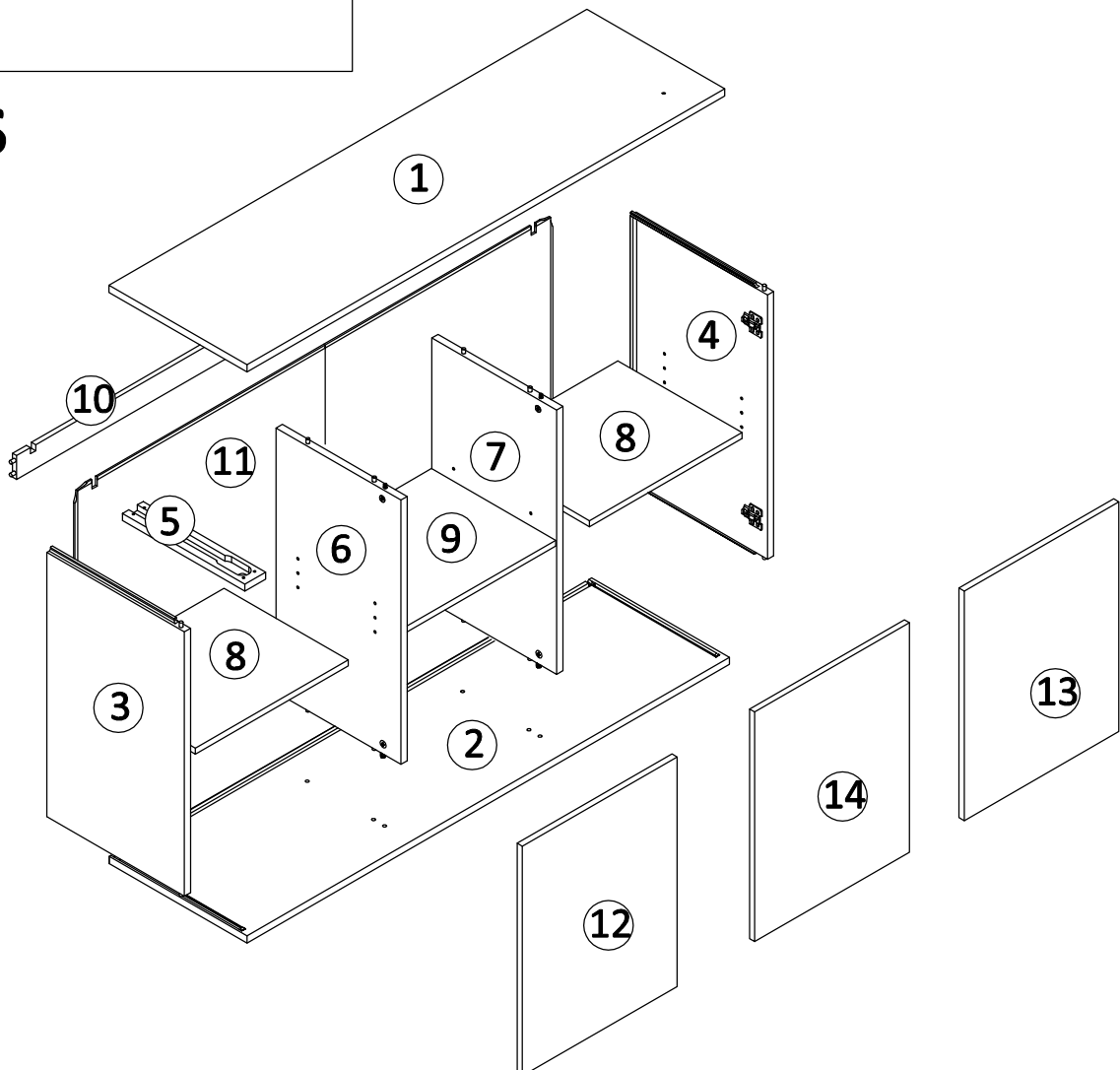

GUIDE

Assembly Instructions

Ensure dowel is aligned with hole before pushing panel into groove

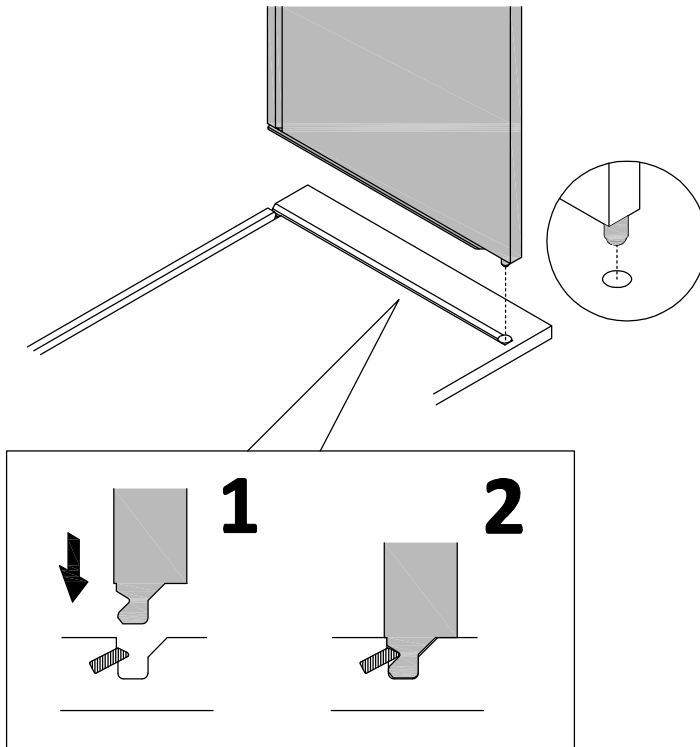

Disassembly Instructions

Use Disassemble rod 'M' and gently slide in to the small triangle as shown below marked 'KEY'

We highly recommend watching the quick help video before disassembling. Simply place a phone camera over the QR code below for a quick link to the video

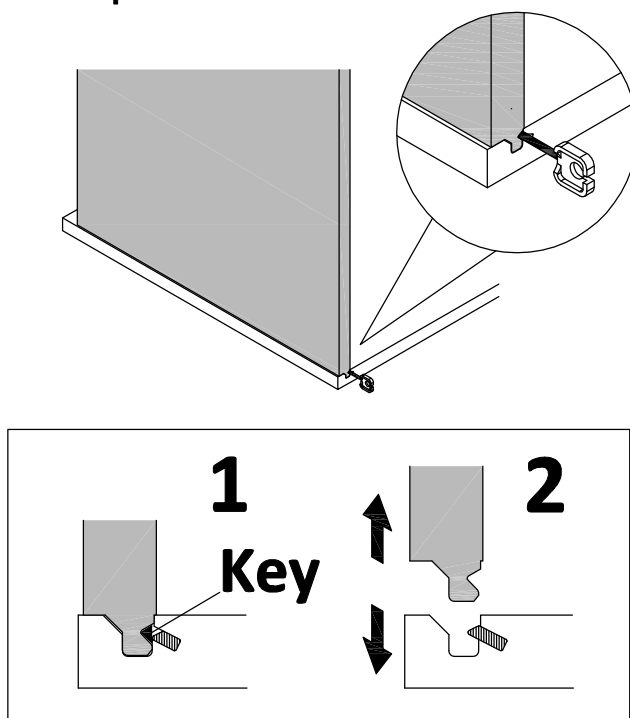

1

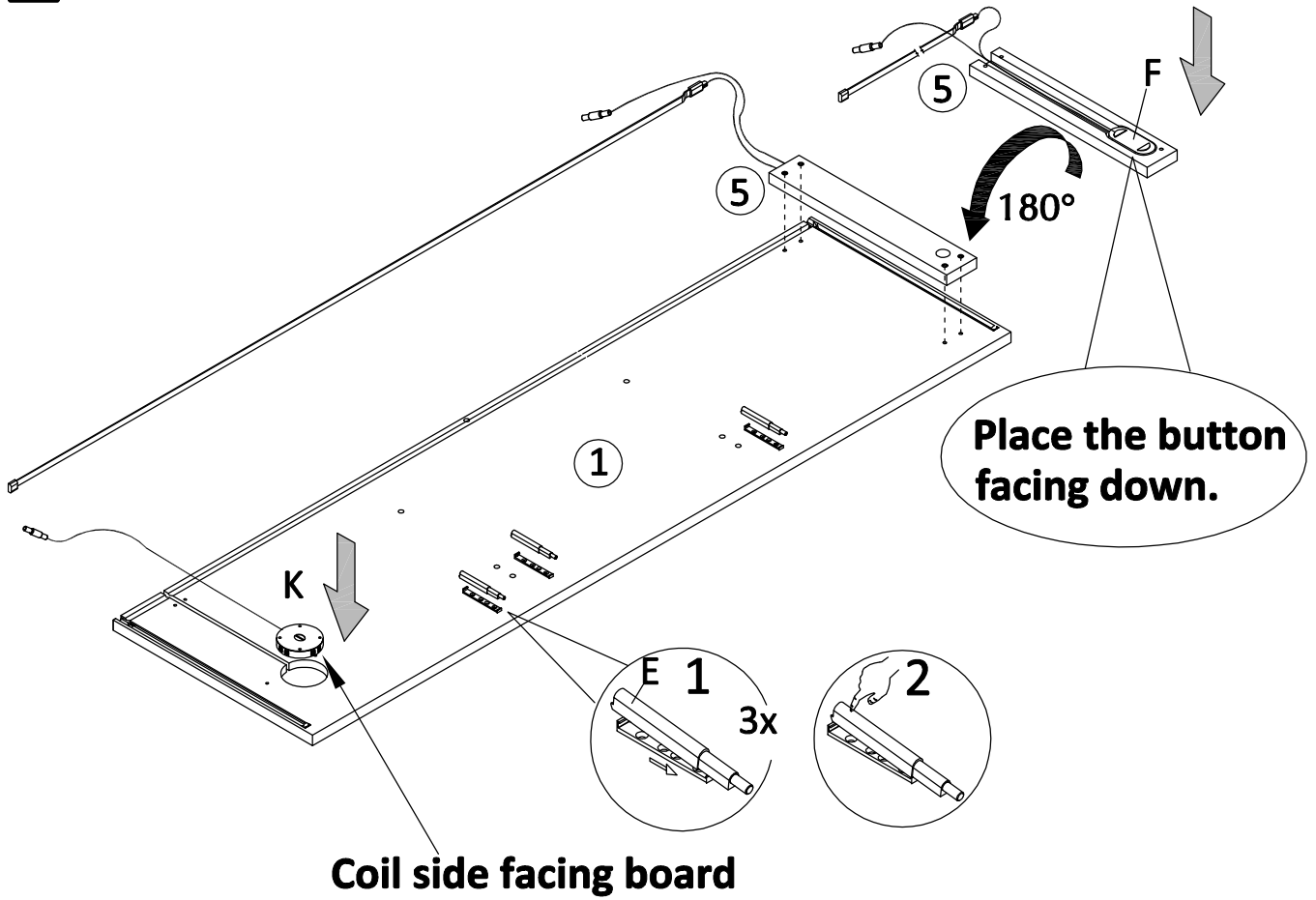

2

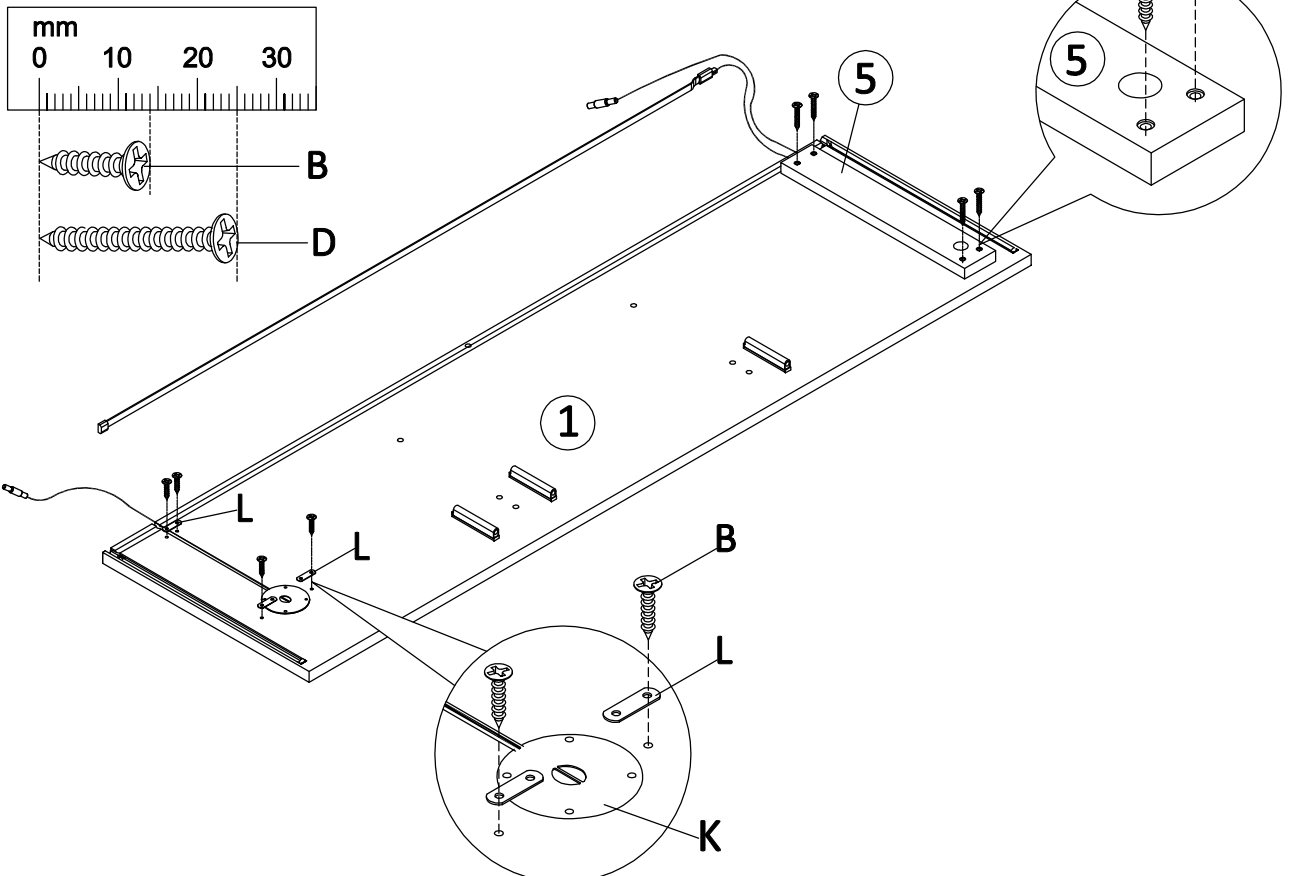

3

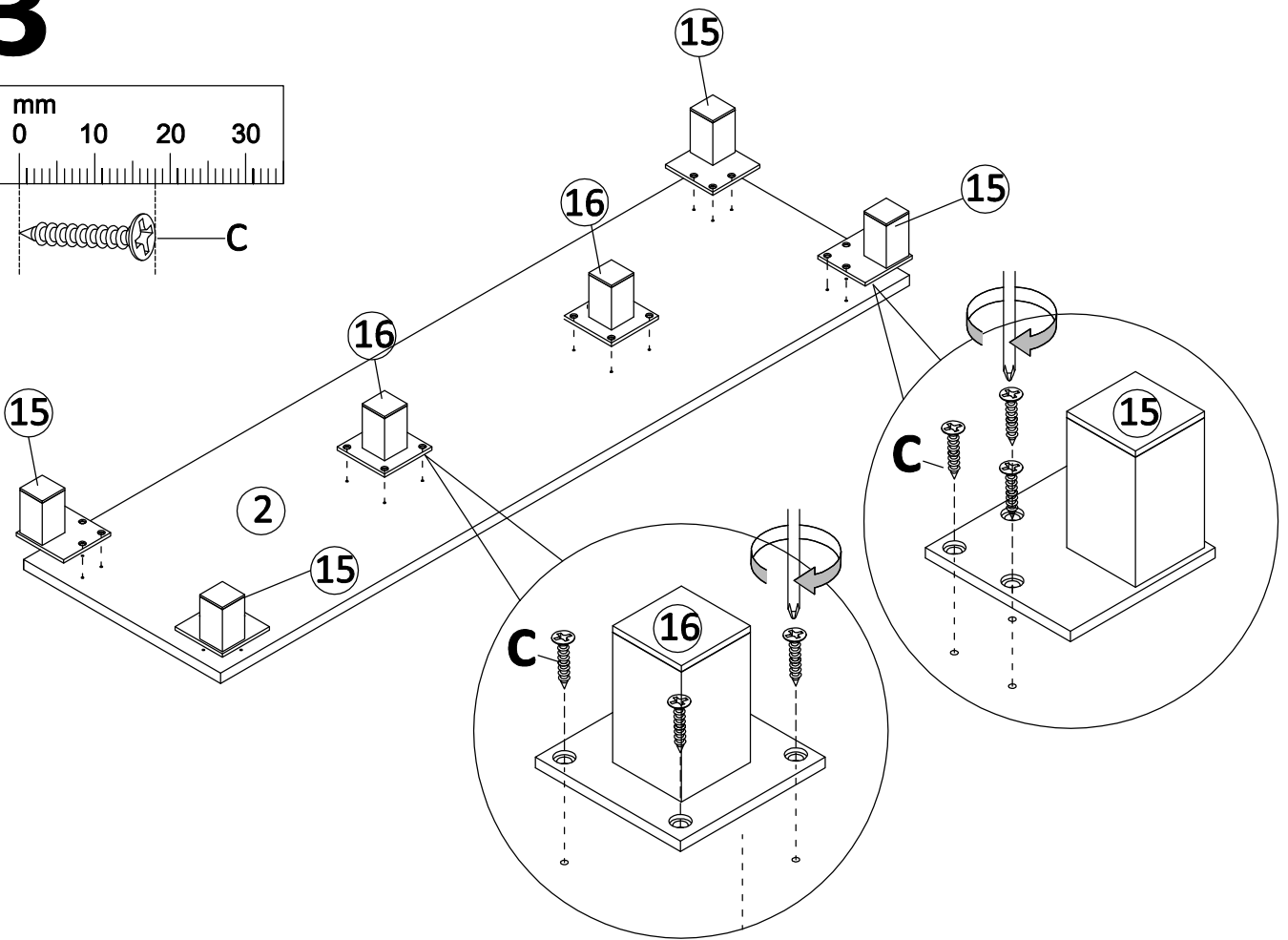
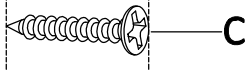
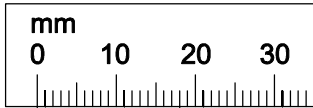

4 NOTE : Panels should sit comfortably in position, do not force them, if they do not fit comfortably, they are likely to be UPSIDE down.

ENSURE Panels 6&7 are not UPSIDE down or the Click System will not line up

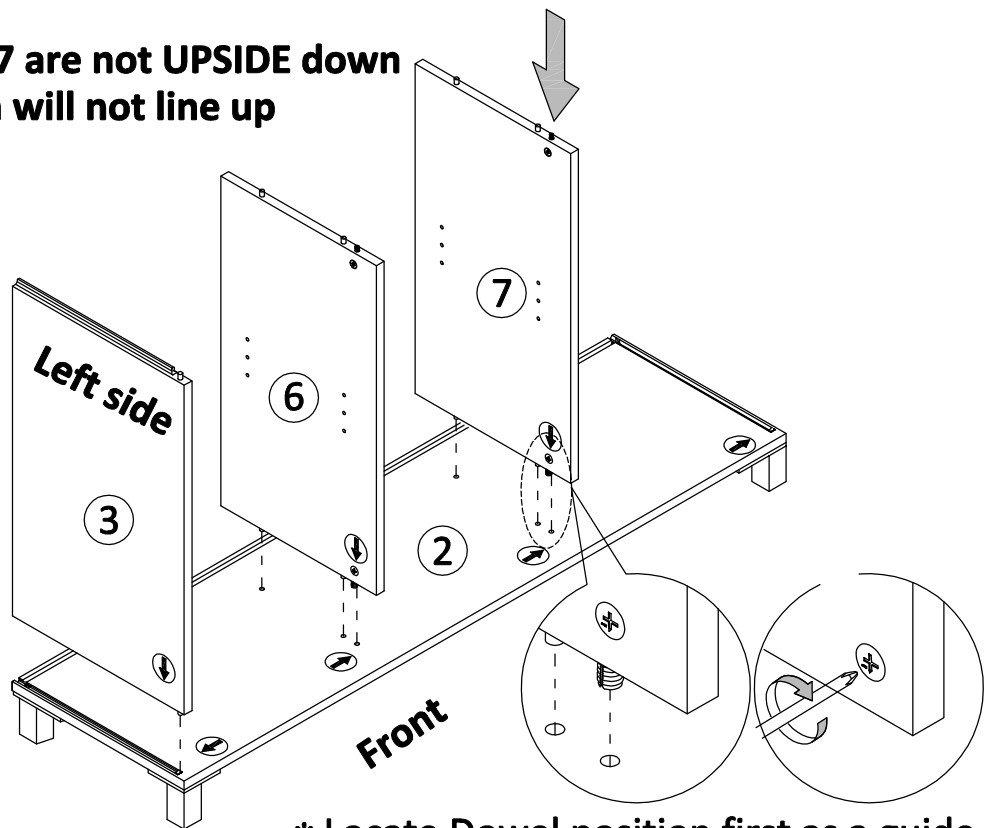

* Locate Dowel position first as a guide

5

* Groove on back panel must be this side

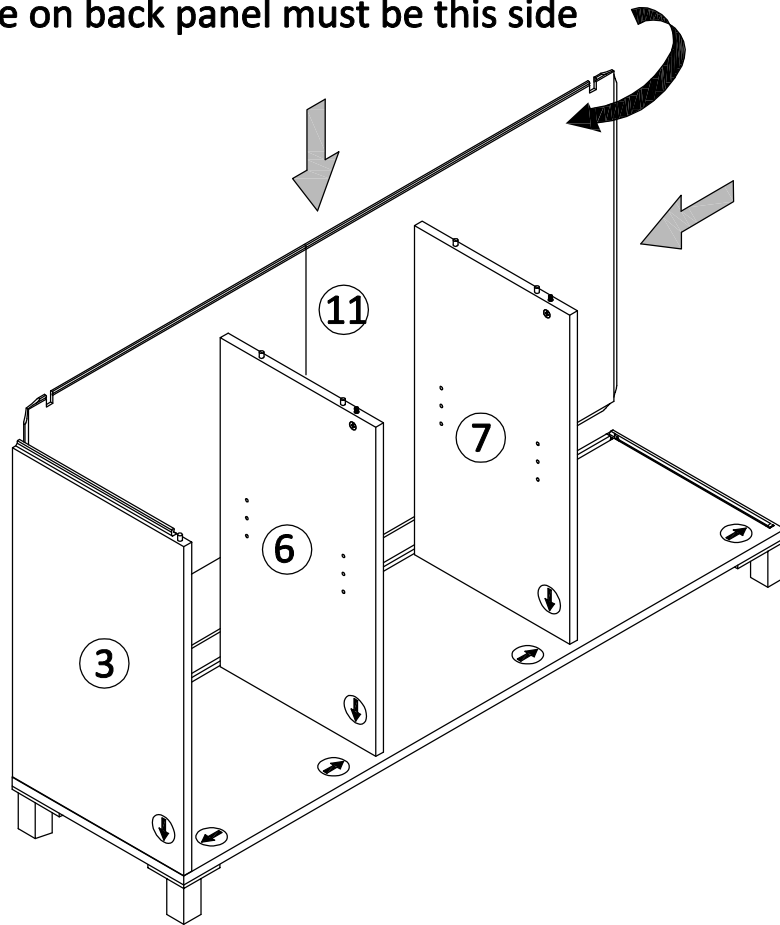

6

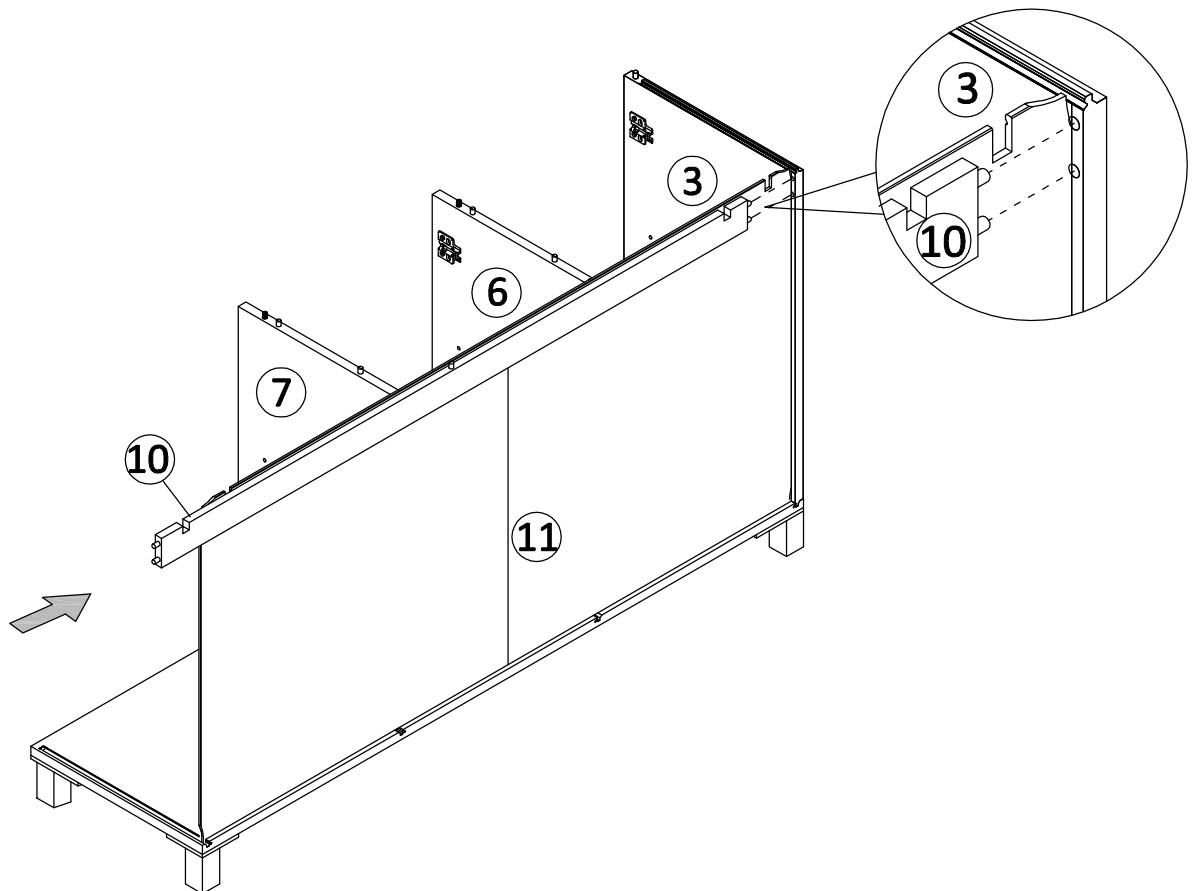

7

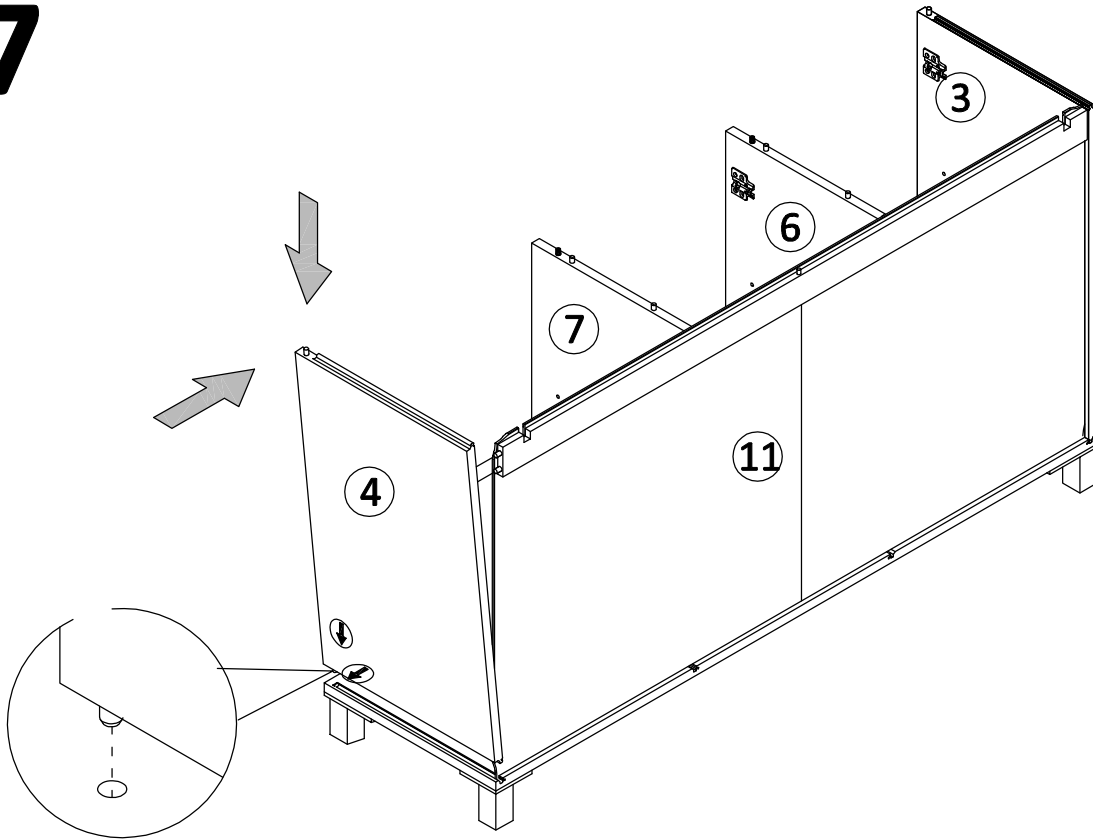

* Locate Dowel position first as a guide

8

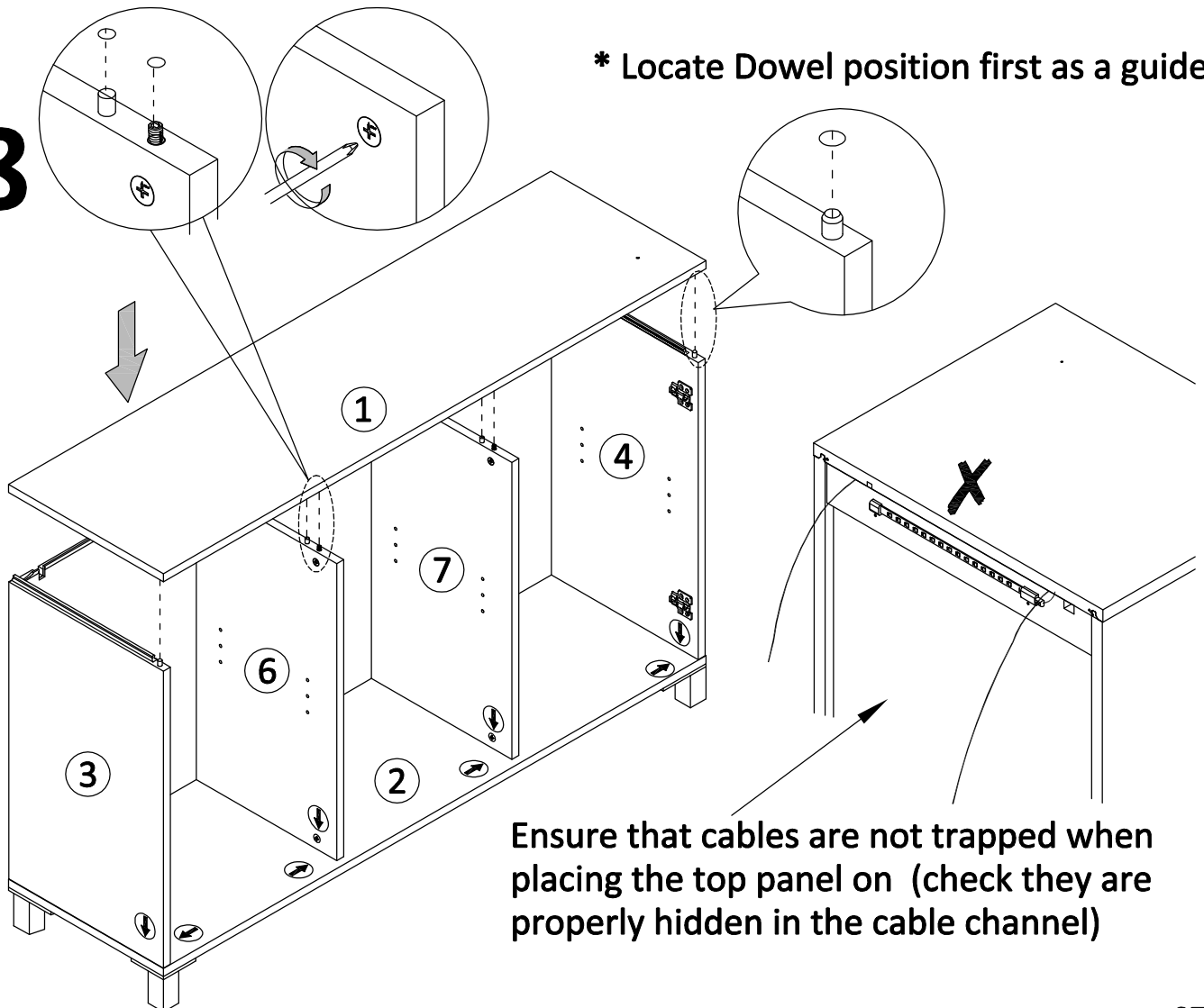

* Locate Dowel position first as a guide

Ensure that cables are not trapped when placing the top panel on (check they are properly hidden in the cable channel)

9

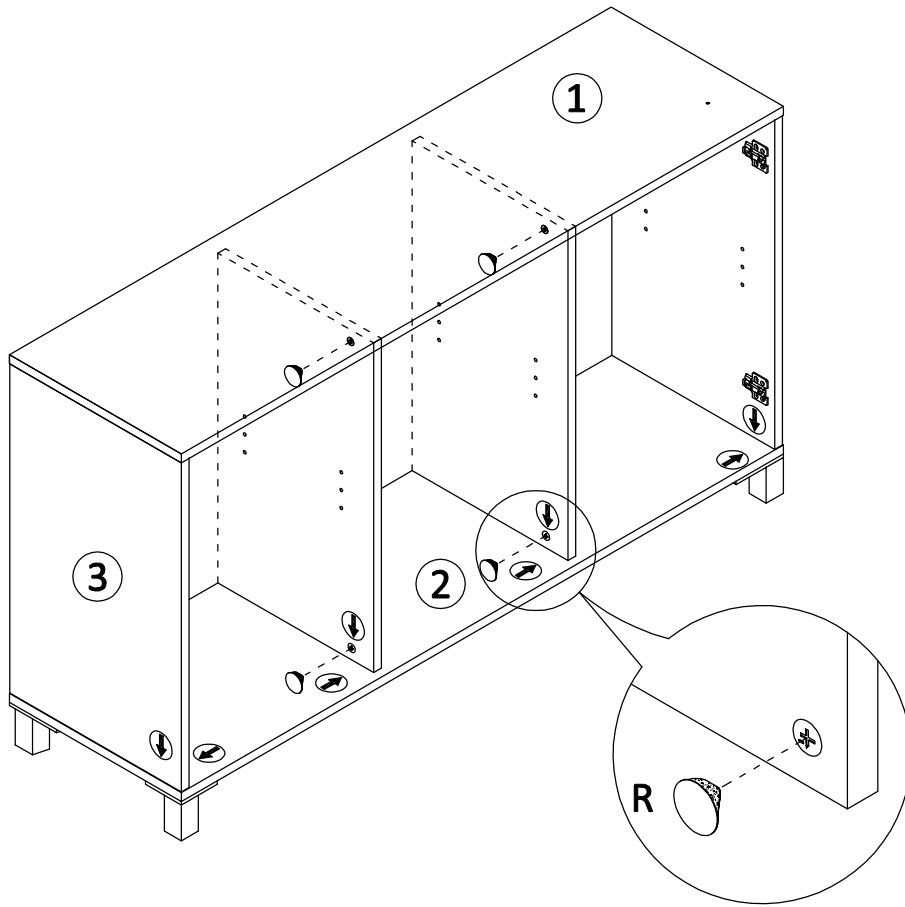

10 PLEASE FOLLOW THE STEPS TO ENSURE NO DAMAGE.
1. Screw in clip 'I'- ensure surface is DUST FREE

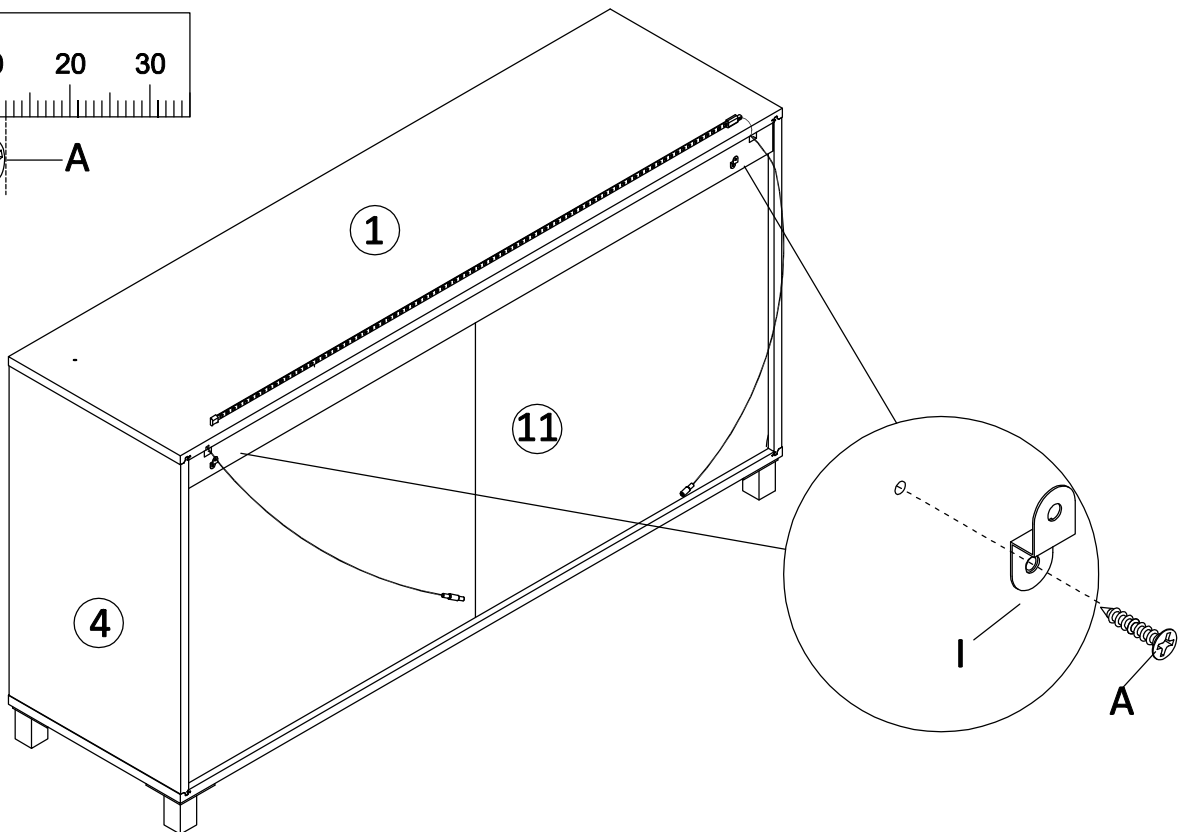
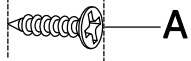
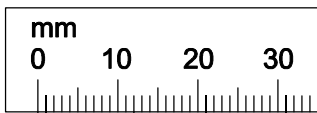

11

CAUTION, When peeling off LED adhesive strip, take extra care to peel ONLY the protective strip, not the adhesive strip.

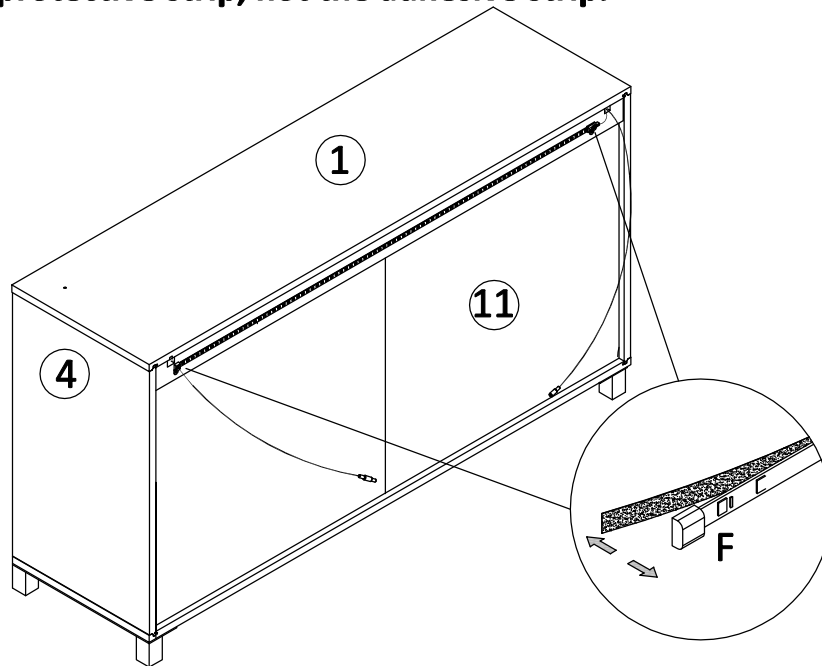

2. Do not remove LED strip backing yet. Place LED strip in position under the clip and lay LED strip in place.
3. Start from the CLIP end, remove the LED strip backing with care and place in position on the edge of the back panel pressing firmly.
4. Gently pull the wires so that the end of the LED strip is straight and sticking in position.

12

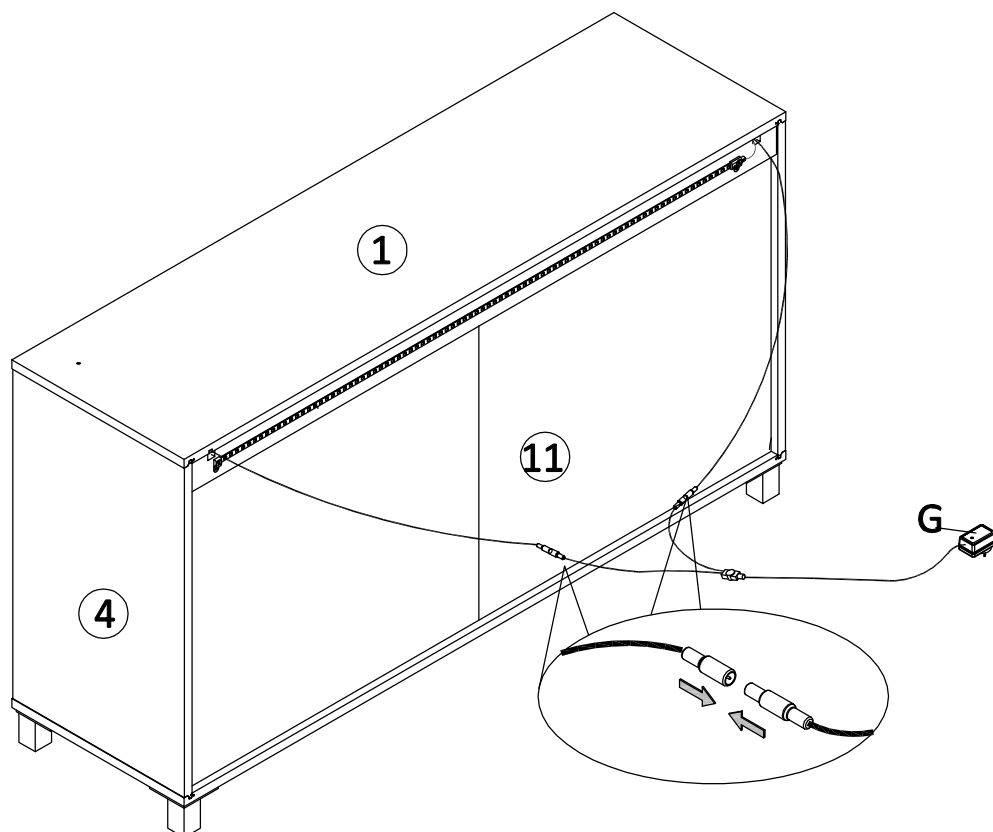

13

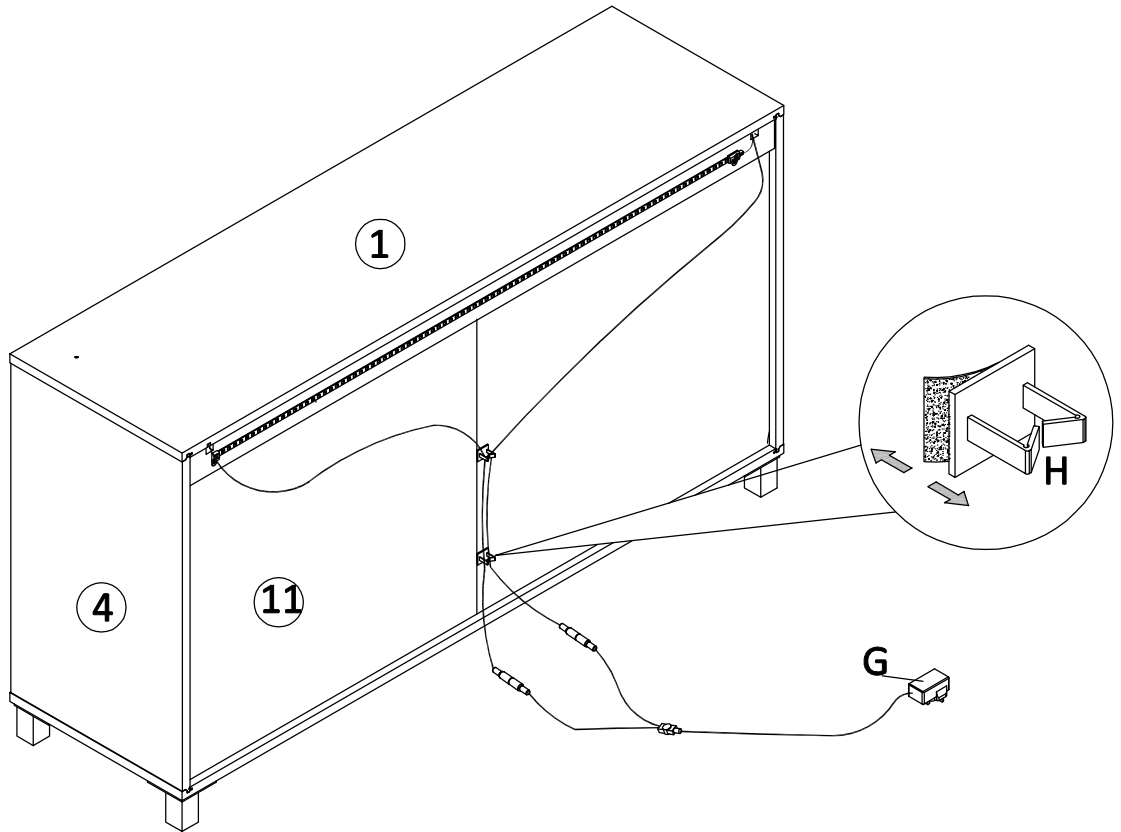

14

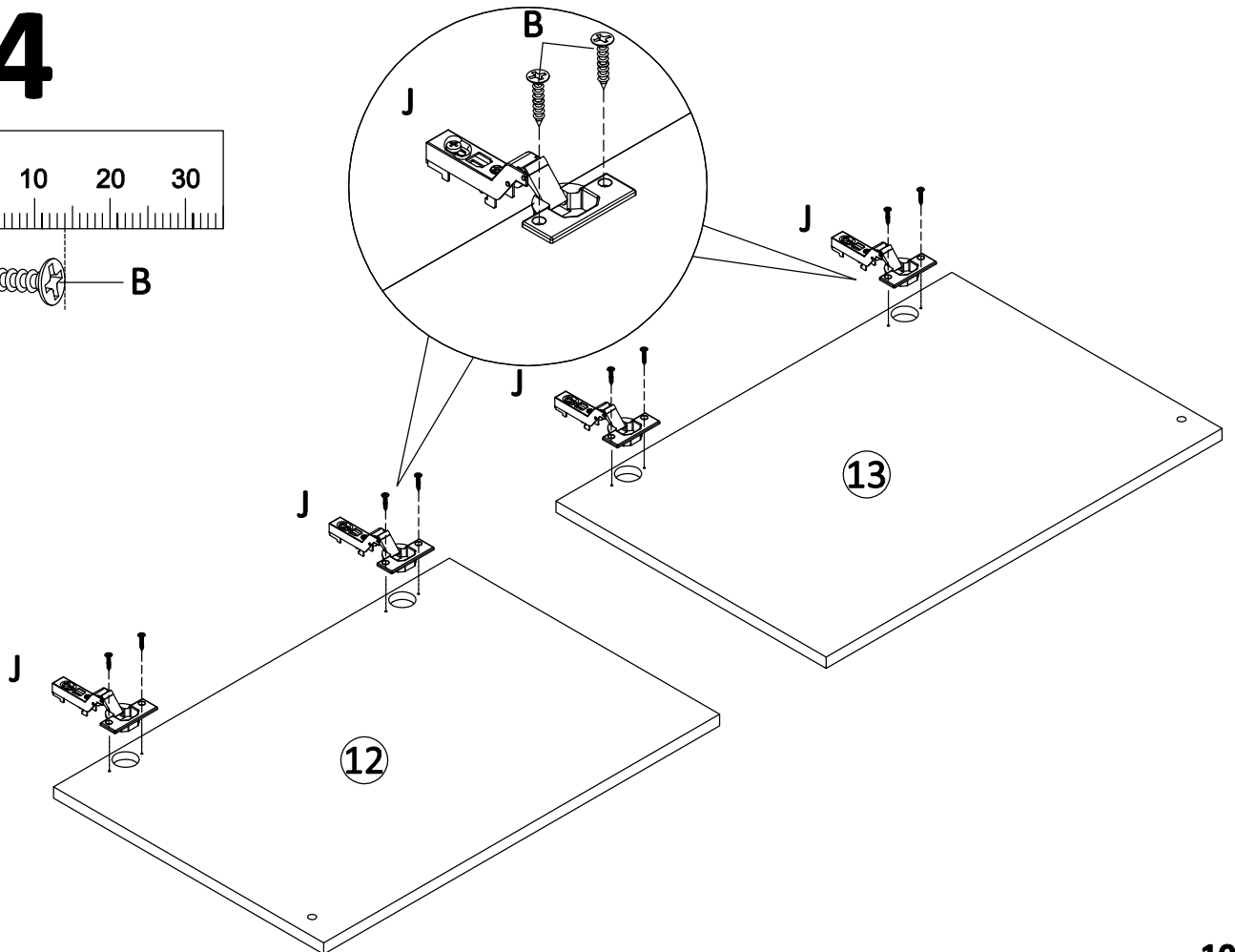
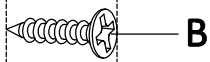

15

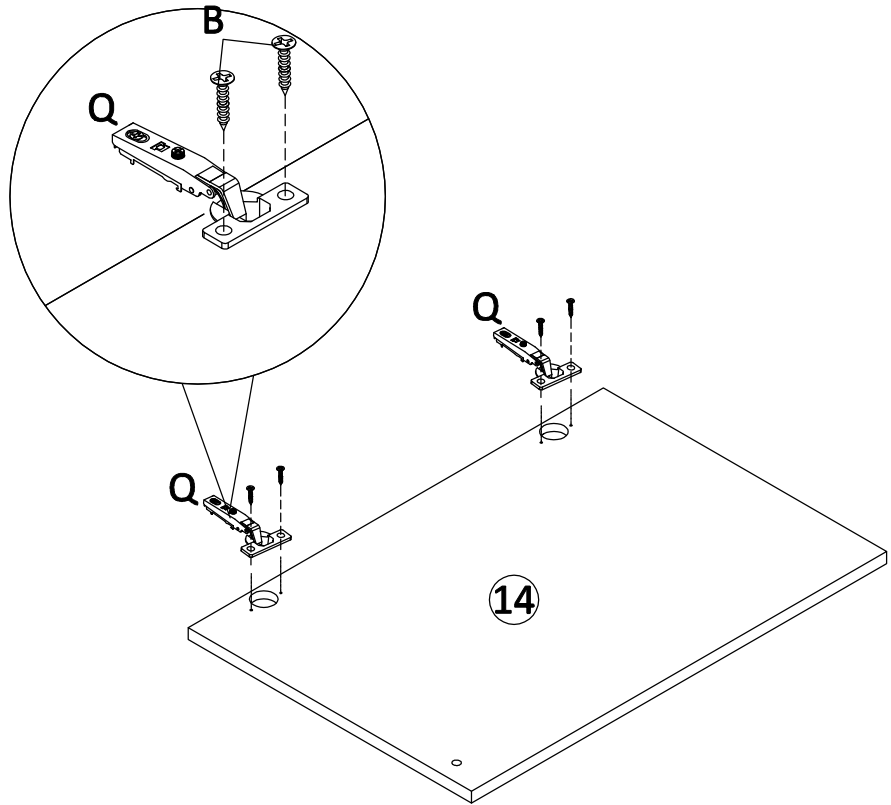
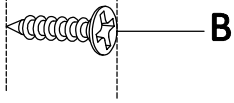
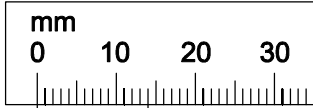

16

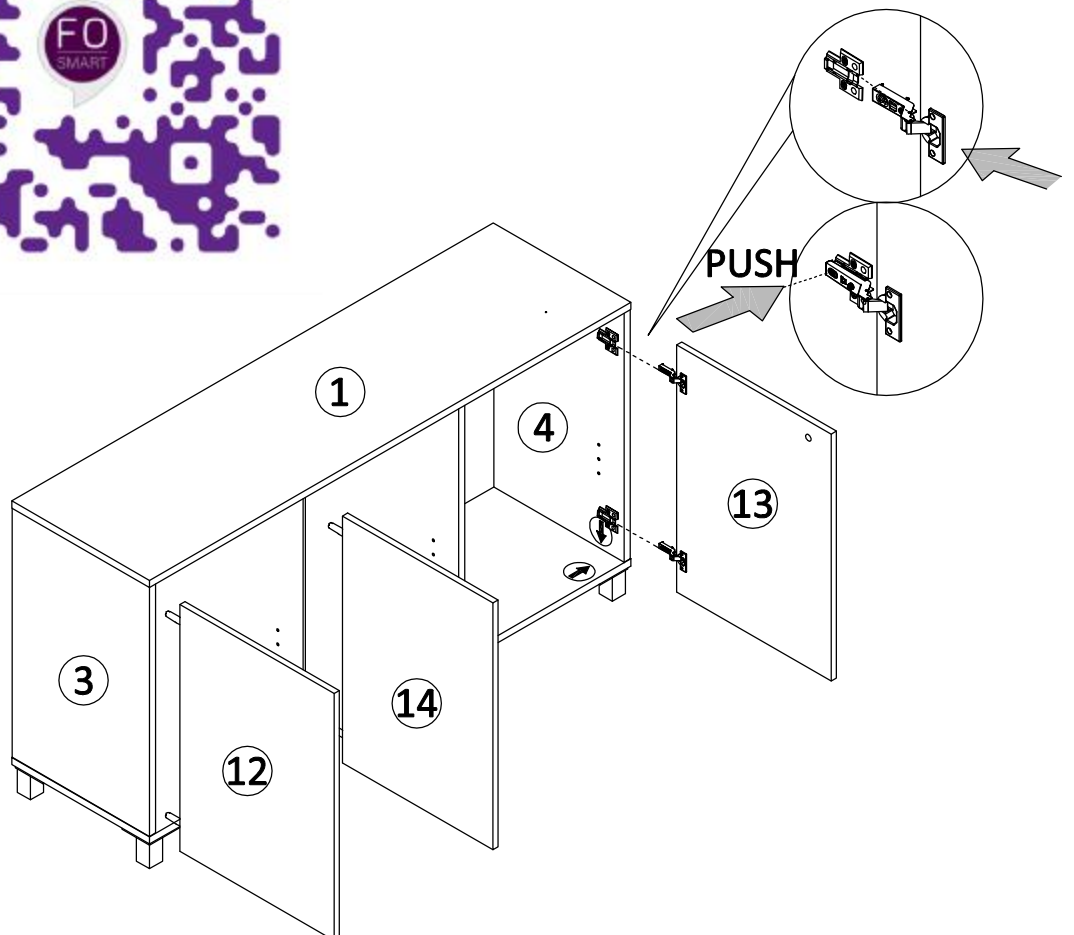

17

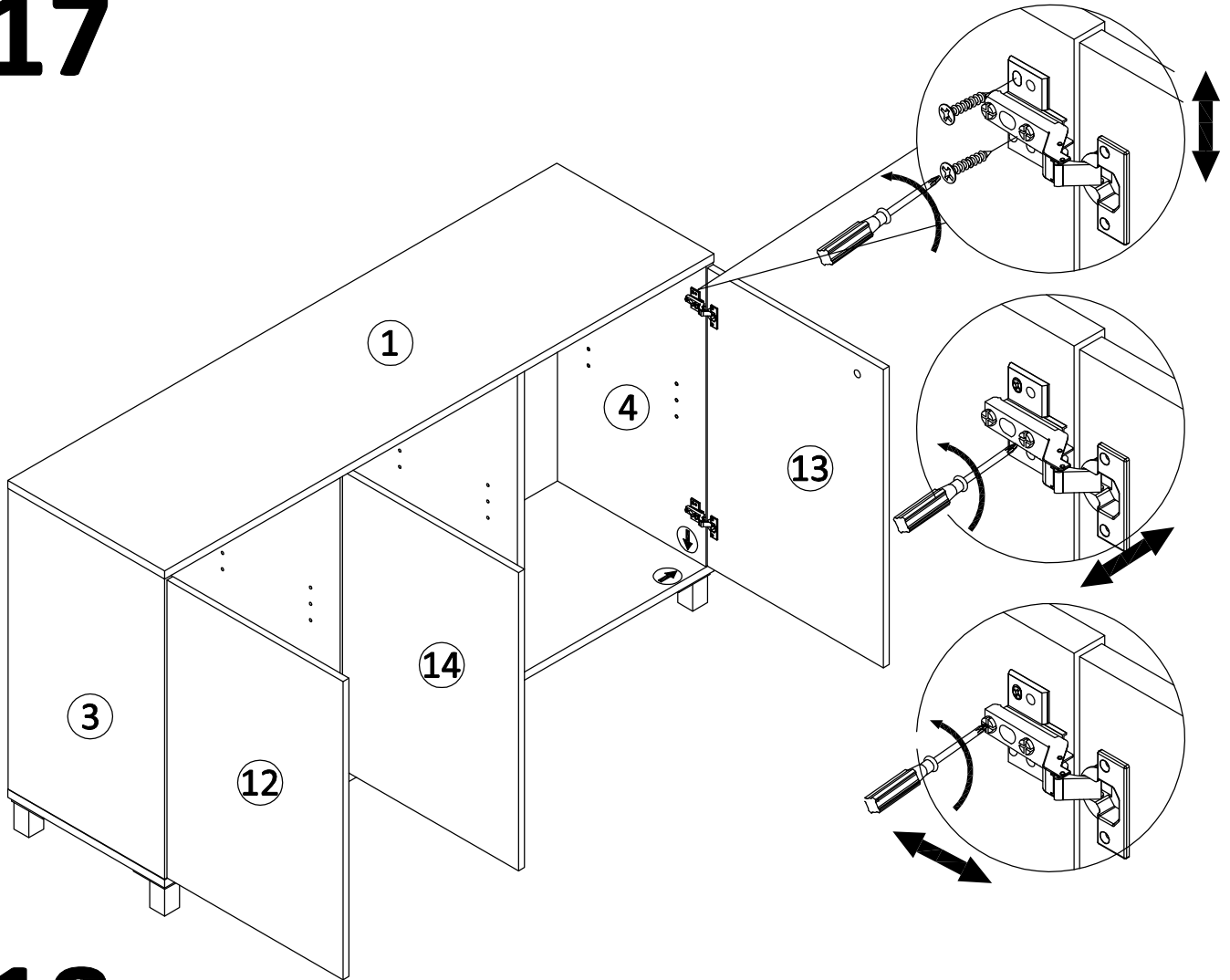

18

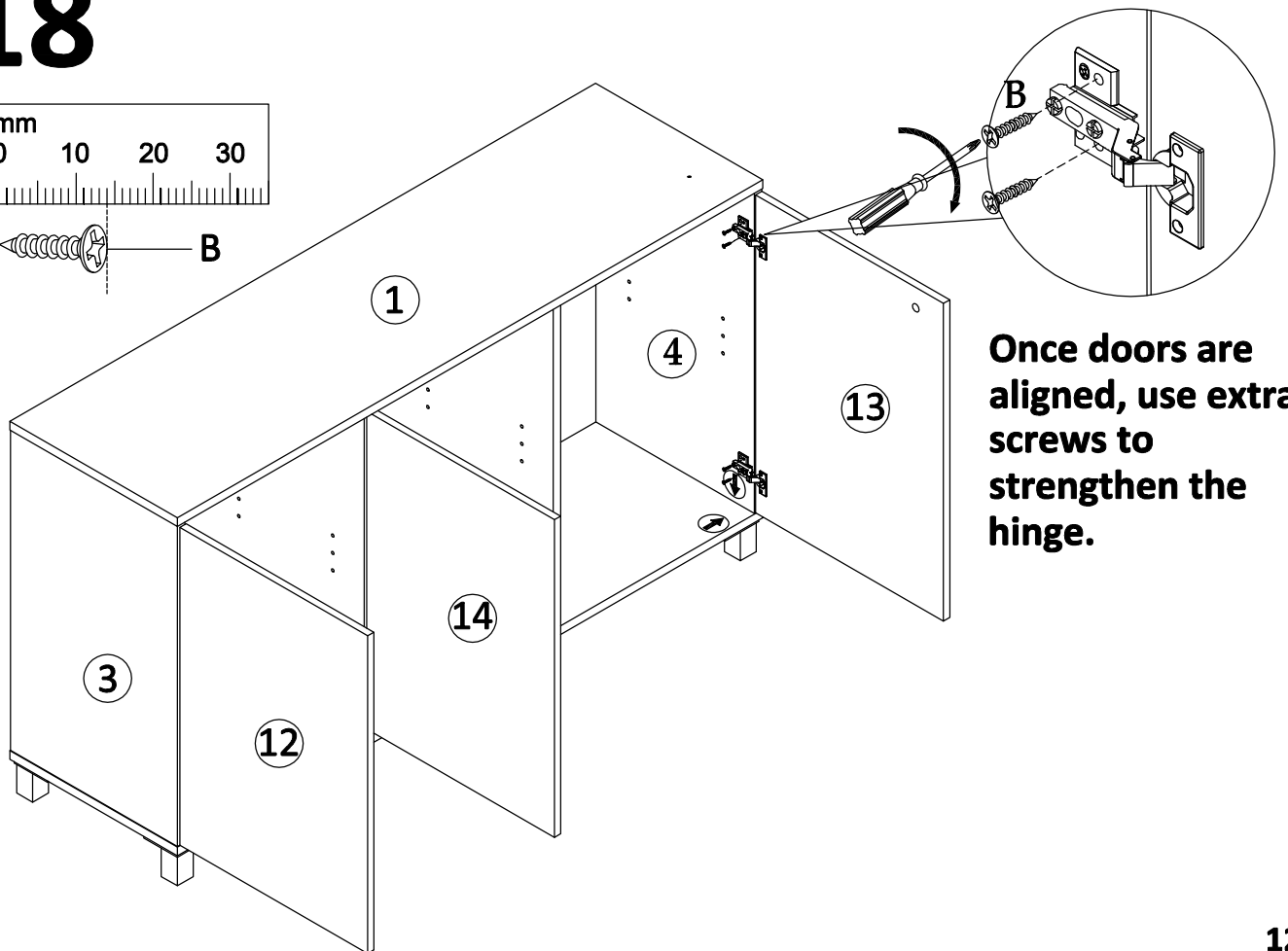
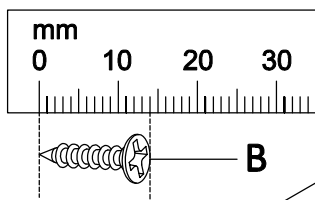

Once doors are aligned, use extra screws to strengthen the hinge.

19

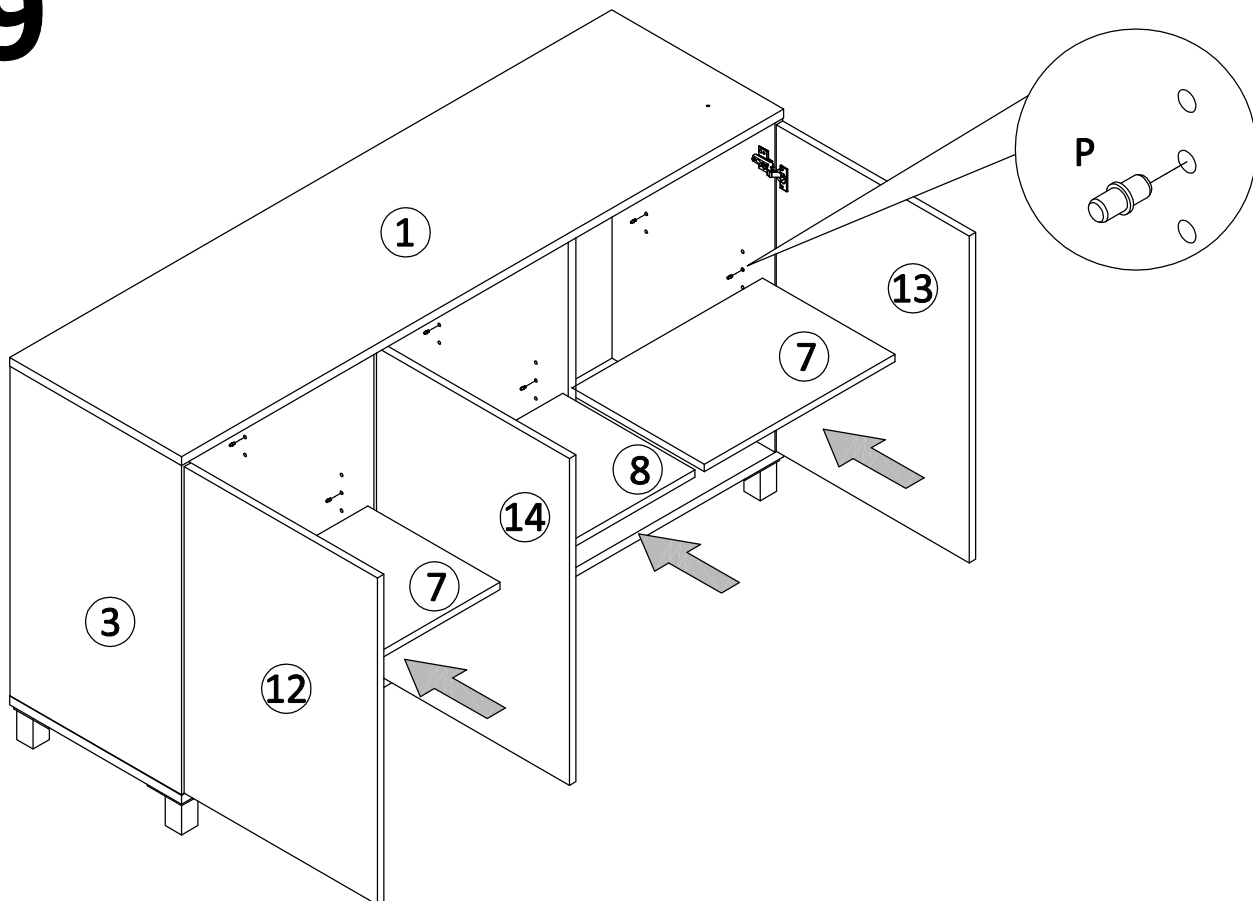

20

NOTE: If the push to open mechanism is not working properly, Simply turn the end of the barrel to adjust.

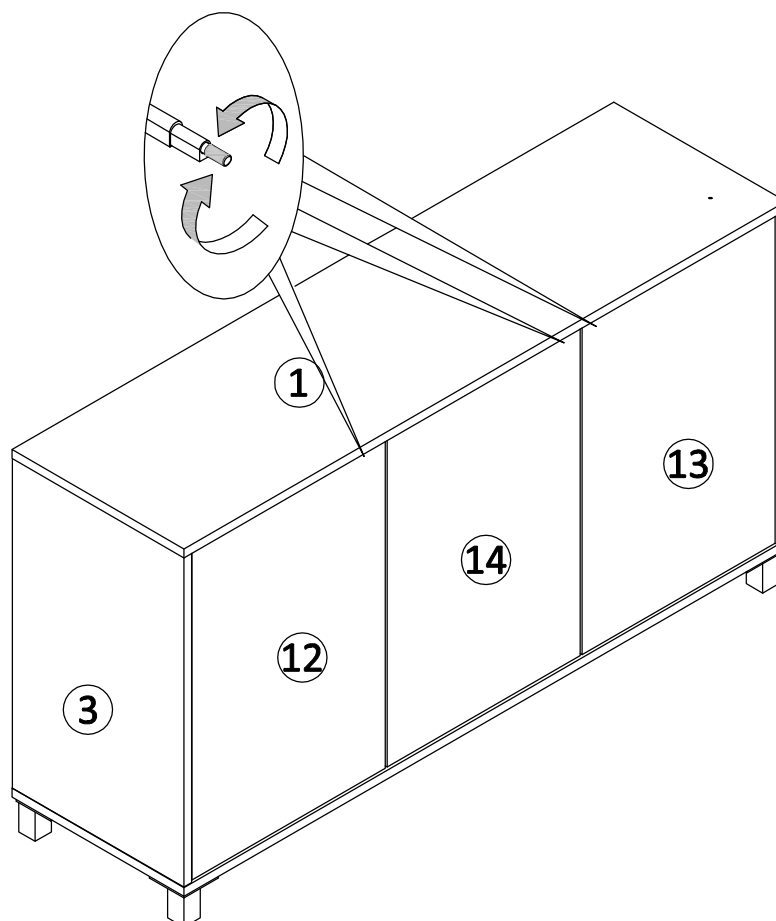

20

WARNING!

Due to risk of overturning, this unit must be used with the wall attachment device/s provided

Please read these assembly instructions carefully as failure to adhere and non use of strap or brackets cause the product to move and possibly lead to damage and/or injury if improperly fitted. If in doubt consult a qualified technician.

1. Place the unit into required position.
2. Ensure unit is level before securing to the wall.
3. Attach a bracket (N) to the wall.
4. Move the unit into its final position. Thread a strap (O) through the bracket (N) as show in the below illustration, tighten strap (O) until snug. Do not over tighten.
5. Repeat the step 3 & 4 for the second strap/brackets fixing.
6. Make sure the bracket (N) is firmly attached to wallboard and unit and the strap (O) is snug.
7. Please note that the wall fixings such as wall plugs are not supplied - please secure the unit to the wall using the appropriate fixings for your wall type.

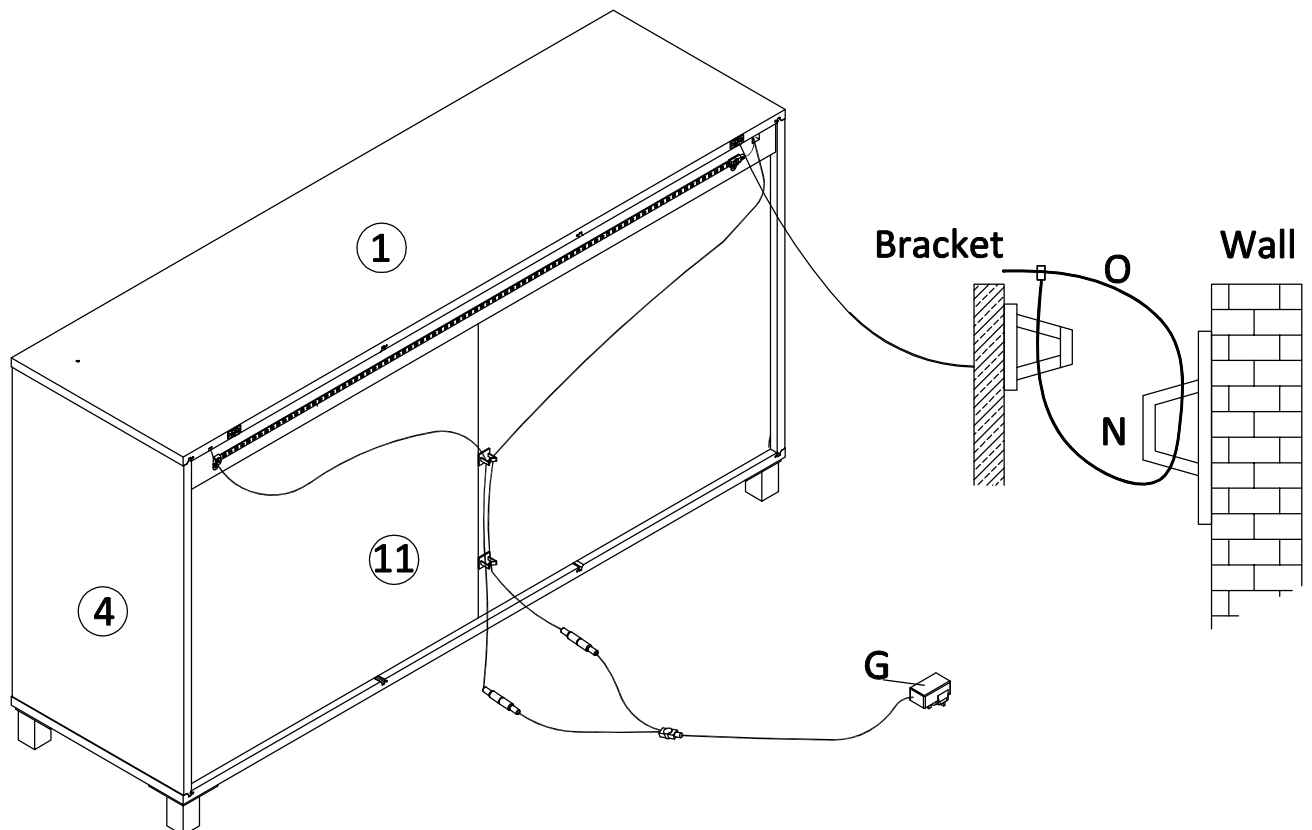

21 Disassembly Instructions

Gently insert Disassembly rod 'M' in to the triangle shown in the diagram as 'KEY' . Once all the way in, the panels will come apart. Due to the click system, the panels may need a gently 'nudge or tap ' to release them.

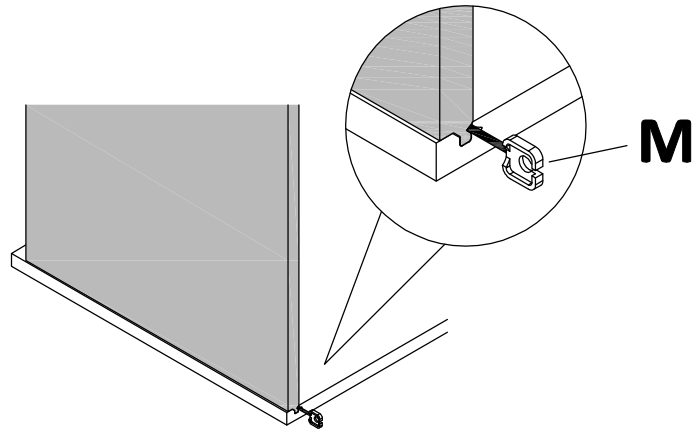

Insert rod 'M' into each section panel to disassemble panel at a time

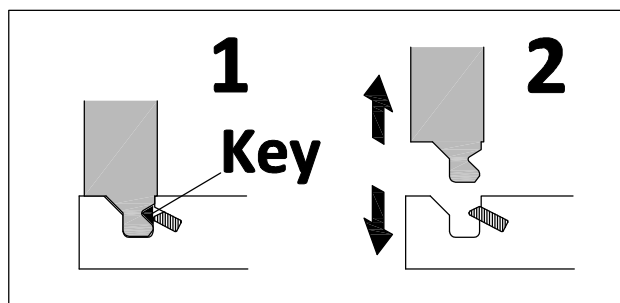

We highly recommend watching the quick help video before disassembling. Simply place a phone camera over the QR code below for a quick link to the video



22

Finish - Remove all visible stickers when assembly is fully completed.

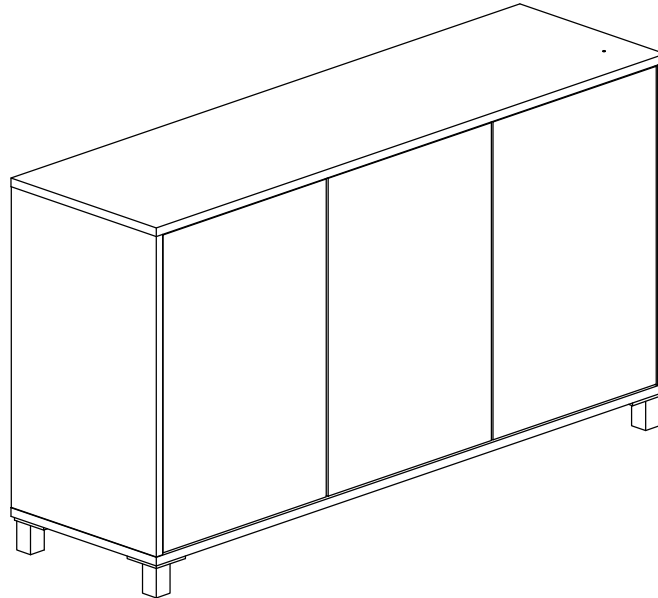

CLEANING ADVICE:

To avoid scratching the surfaces, clean only with a non abrasive cleaner.

NOTES ON SETTING UP WIFI

The LEDS lights only work on 2.4 GHz, they will not work on 5.0 GHz

Most homes are 2.4 GHz or operate a dual function. If for any reason the LED lights are not connecting to the app or Alexa, please check the router setting. Most routers will operate both 2.4 and 5.00 GHz so there should be no problem.

In commercial premises, there maybe software to block access connection to unknown apps or services. If this happens, please check with IT Department.

The system will work from a mobile WiFi hotspot from one phone to another. We recommend this approach if there are access issues.

Ensure Bluetooth setting is on.

Using the wireless charging

The wireless charging will only work with Qi enabled wireless charging phones. Please check the phone is wireless charging compatible.

Note: We recommend removing the phone case during the charging process

- Using the plug provided, connect the wireless charger cable to the plug and connect to the power source.
- To charge your phone, simply place the phone on the charging position indicator and the phone will start to charge.
- To check if the charger is working, simply move the phone and if the red light is on, this indicates that the charger is working. You may need to reposition the phone slightly if the red light is not showing.
- For the charger to work properly, the charging position within the back of the phone needs to sit aligned with the central red light.
- An element of heat is created during the wireless charging process, this is perfectly normal and safe. The charger has a built-in temperature control and will not over heat.
- If a phone has a thick case, it may affect the wireless charging, to resolve this remove the phone case during charging.
- If a phone case is used and charging process seems to stop and start, remove the phone case and try again, this should work better.

NOTE : there may be a few second delay for the phone to register as charging which is normal.

For a guidance and help and contact details, please visit our website :
www.frankolsenfurniture.co.uk

QUICK HELP GUIDE & TIP VIDEOS

LED LIGHT SET UP GUIDES



Pairing mode



Re-setting pairing mode



AP mode



Re-setting AP mode



Help is wireless charging phone

Simply hold the camera on a smartphone over the QR code above to go to a quick link to the help video