



# CAMPANIA INTERNATIONAL

CAMPANIA INTERNATIONAL  
2452 QUAKERTOWN RD, SUITE 100  
PENNSBURG, PA 18073  
PHONE: (215) 541-4330  
FAX: (215) 541-4628  
[www.campaniainternational.com/projects/](http://www.campaniainternational.com/projects/)

SELECT DESIRED COLOR:

- AGED LIMESTONE (AL)
- ALPINE STONE (AS)
- BROWNSTONE (BR)
- COPPER BRONZE (CB)
- ENGLISH MOSS (EM)
- FERRO RUSTICO NUOVO (FN)
- NATURAL (NA)
- NERO NUOVO (NN)
- PIETRA NUOVA (PN)
- TRAVERTINE (TR)
- VERDE (VE)
- GREYSTONE (GS)

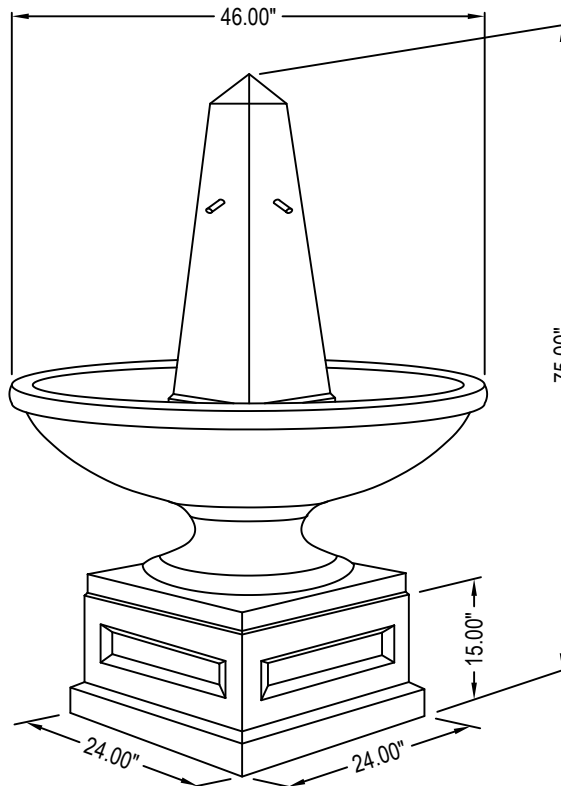

CONDOTTI OBELISK FOUNTAIN (FT-293)

WEIGHT: 1295 LBS

DIMENSIONS: 46.00" W X 75.00" H

MANUFACTURER NOTES:

1. PLEASE REFER TO LISTING 4841-101 FOR PATINA OPTIONS.

NOTES:

1. INSTALLATION TO BE COMPLETED IN ACCORDANCE WITH MANUFACTURER'S SPECIFICATIONS.
2. DO NOT SCALE DRAWING.
3. THIS DRAWING IS INTENDED FOR USE BY ARCHITECTS, ENGINEERS, CONTRACTORS, CONSULTANTS AND DESIGN PROFESSIONALS FOR PLANNING PURPOSES ONLY. THIS DRAWING MAY NOT BE USED FOR CONSTRUCTION.
4. ALL INFORMATION CONTAINED HEREIN WAS CURRENT AT THE TIME OF DEVELOPMENT BUT MUST BE REVIEWED AND APPROVED BY THE PRODUCT MANUFACTURER TO BE CONSIDERED ACCURATE.
5. CONTRACTOR'S NOTE: FOR PRODUCT AND COMPANY INFORMATION VISIT [www.CADdetails.com/info](http://www.CADdetails.com/info) AND ENTER REFERENCE NUMBER 4841-320

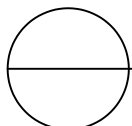

## SIGNATURE COLLECTION

SIGNATURE COLLECTION: CONDOTTI OBELISK FOUNTAIN