

Assembly INSTRUCTIONS

Wall Cabinets

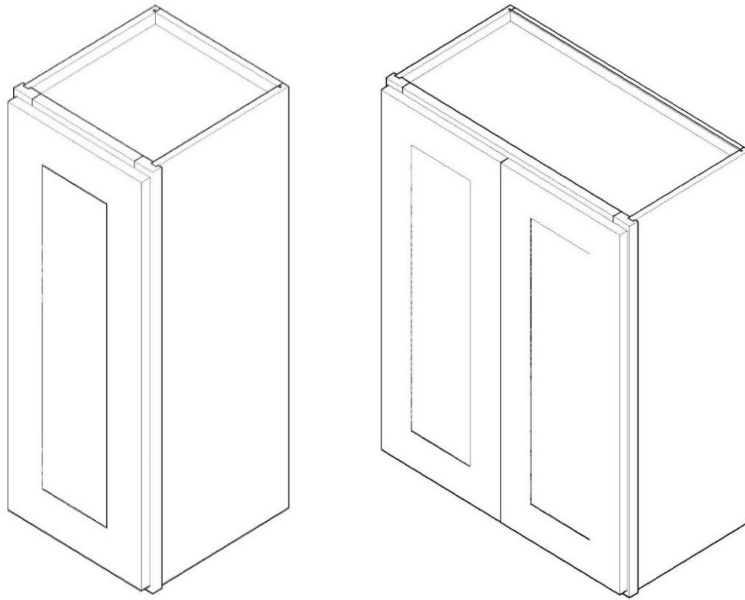

ASSEMBLY INSTRUCTIONS

Unpacking Precautions

If using a sharp object to unpack the cabinet components and the packing materials, be careful to avoid scratching or damaging the cabinet components. The various packing materials may be used to protect the cabinet components during assembly. During the unpacking process, place the various components away from and to the side of the work area so that they will not be inadvertently knocked over or otherwise damaged.

Base Cabinet Model Variations

These assembly instructions include all the steps required to assemble a Wall Cabinet with or without a Shelves.

Required tools
Phillips screwdriver
Rubber mallet
Wood Glue



Hardware Screw Sizes

(I) (Small 1/2")

(J) (Medium 1")

(K) (Large 1 1/8")



Step 1:

Lay the face frame with doors (A) on a soft surface, doors facing down.

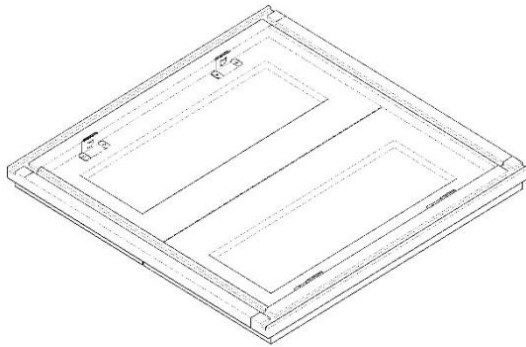

Step 2:

Using the wood glue, squeeze a small bead of glue in all grooves before assembling the cabinet sides, bottom, top and back panels. Be careful not to use too much glue, this could cause excess glue to squeeze out and onto the panels. If this should happen, be sure to remove quickly.

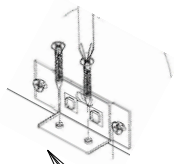

Step 3:

Slide the Left Side panel (L) in the left groove of the face frame, and mount the male clip to the face frame with the screw driver. Each male clip will need 2 small screws (I).

fig 1

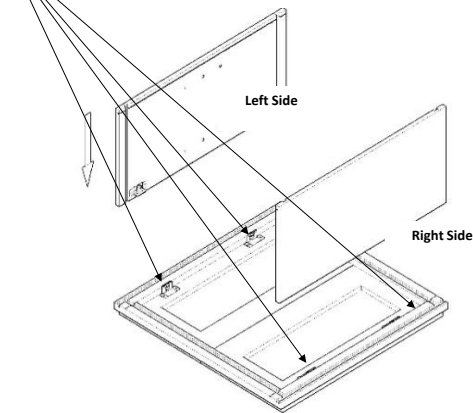

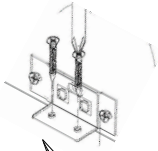

Step 4:
Slide the top panel (T) and bottom panel (B) into the grooves of the right and left side panels, and then into the groove in the frame below until it is fully seated.

Step 5:
There're two clips on the bottom panels and two clips on the top panels. Each male clip will need 2 small screws(I).

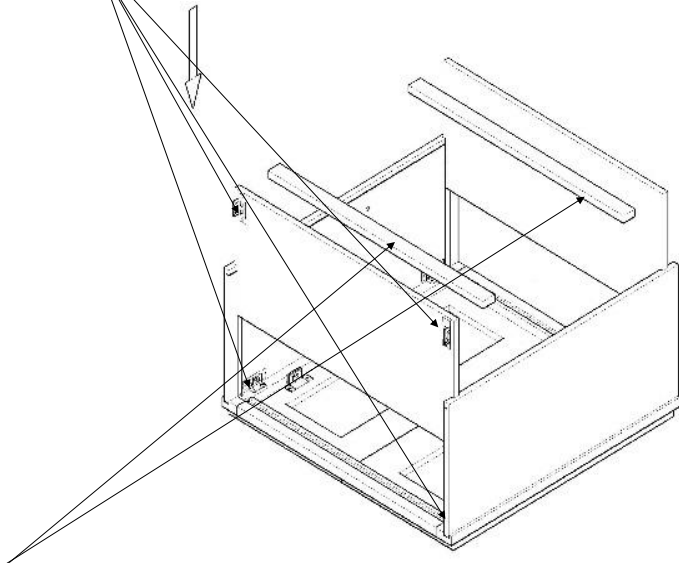

** The two optional hanging bars are included, These are to be installed at the top & the bottom of the inside of the cabinet prior to mount to wall.

Step 6:
Insert the Back Panel (D) between the two Side Panels.

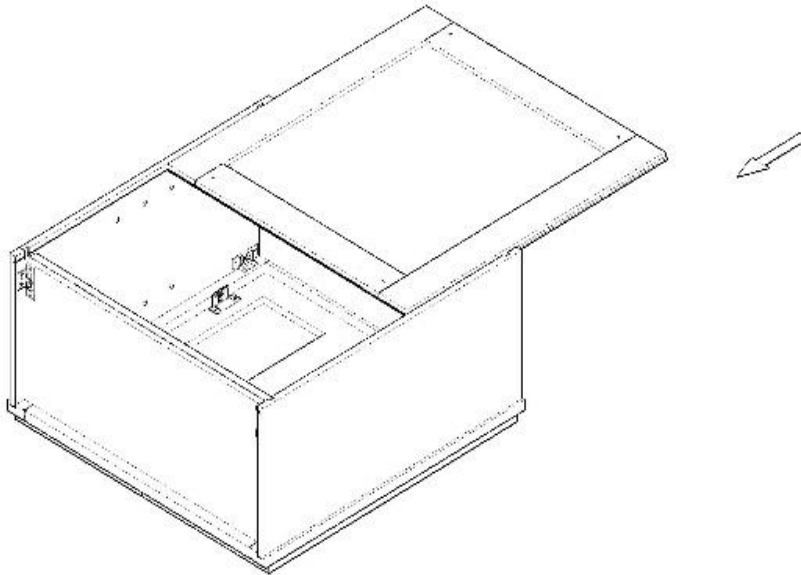

Step 7:

Use the Long Screws (K), and the pre-drilled holes , to attach the back panel to the edges of the bottom

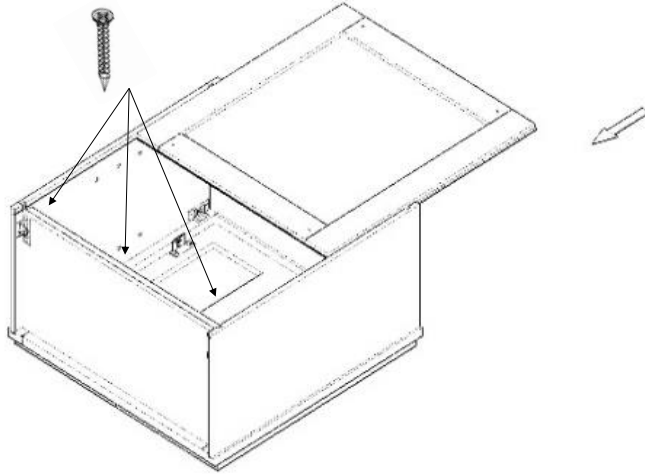

Step 8:

1. Put the shelf pins on the left and right side panels using the holes provided. Be sure pins on the right & left are in the same position on each side to insure a level fit.

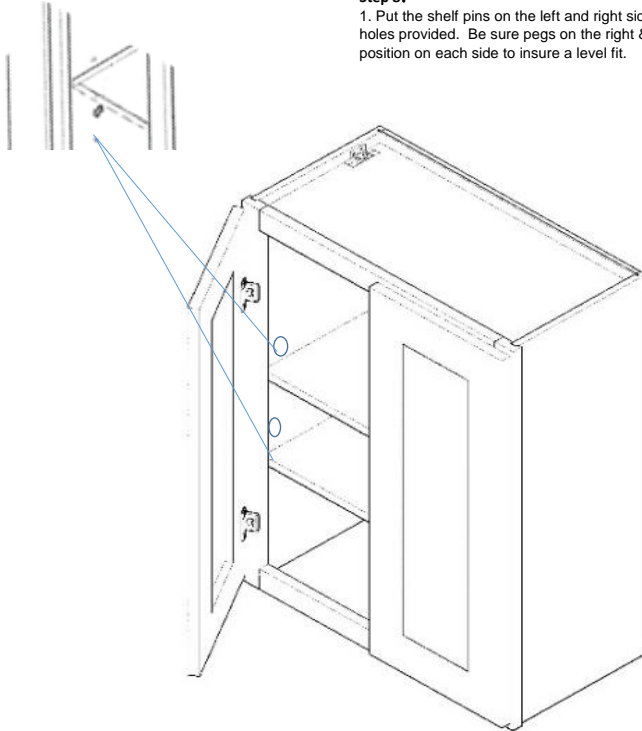

Step 9 :

Attached rubber bumpers to both the top and bottom of each door.

