

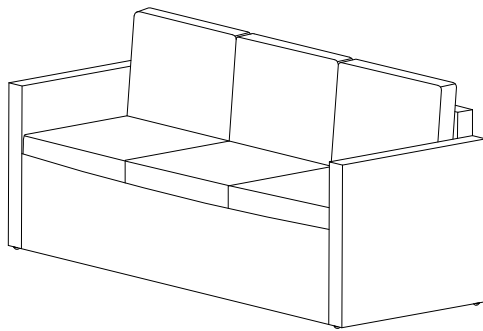

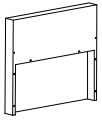

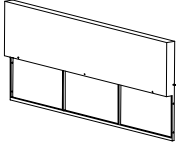

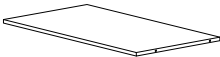

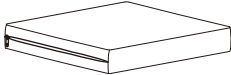

Outdoor Wicker Sofa

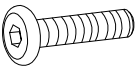
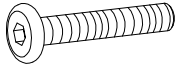
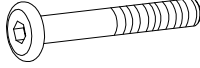

PART LIST

A 	B 	C 	D 	E 
Arm Panel 2 PCS	Back Panel 1 PC	Seat Panel 1 PC	Lower Front 1 PC	Cover of Seat Cushion * 3 PCS
F 	G 	H 	*Please note cushion covers will ship separately.	
Core of Seat Cushion 3 PCS	Cover of Back Cushion * 3 PCS	Core of Back Cushion 3 PCS		

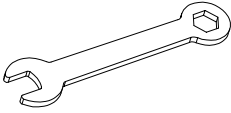
HARDWARE LIST

#1 	#2 	#3 	#4 	#5 
M6*25mm Short Bolt 3 PCS	M6*40mm Medium Bolt 4 PCS	M6*50mm Long Bolt 11 PCS	M6mm Nut 15 PCS	M6mm Washer 33 PCS
#6 	#7 	#8 		
M6mm Wrench 1 PC	M6mm Allen Key 1 PC	Adjustable Leveler 6 PCS		

EXTRA HARDWARE LIST

<div data-bbox="70 129 129 181" data-label="Text">#1</div> <div data-bbox="145 219 292 288" data-label="Image"> </div> <div data-bbox="129 324 300 365" data-label="Text">M6*30mm</div>	<div data-bbox="357 129 416 181" data-label="Text">#2</div> <div data-bbox="411 219 596 288" data-label="Image"> </div> <div data-bbox="411 324 579 365" data-label="Text">M6*40mm</div>	<div data-bbox="644 129 703 181" data-label="Text">#3</div> <div data-bbox="691 219 903 288" data-label="Image"> </div> <div data-bbox="697 324 865 365" data-label="Text">M6*50mm</div>	<div data-bbox="932 129 991 181" data-label="Text">#4</div> <div data-bbox="1027 219 1118 297" data-label="Image"> </div> <div data-bbox="1018 324 1136 365" data-label="Text">M6mm</div>	<div data-bbox="1219 129 1278 181" data-label="Text">#5</div> <div data-bbox="1310 239 1417 309" data-label="Image"> </div> <div data-bbox="1294 324 1417 365" data-label="Text">M6mm</div>
<div data-bbox="129 389 293 468" data-label="Text">Short Bolt 1 PC</div>	<div data-bbox="389 389 608 468" data-label="Text">Medium Bo It 1 PC</div>	<div data-bbox="707 389 874 468" data-label="Text">Long Bo It 3 PCS</div>	<div data-bbox="1018 389 1126 468" data-label="Text">Nut 3 PCS</div>	<div data-bbox="1289 389 1425 468" data-label="Text">Washer 3 PCS</div>
<div data-bbox="70 495 129 546" data-label="Text">#8</div> <div data-bbox="169 575 260 667" data-label="Image"> </div> <div data-bbox="161 687 271 725" data-label="Text">M6mm</div> <div data-bbox="129 741 293 851" data-label="Text">Adjustable Leveler 2 PCS</div>				

Step 1. Lay arm panel (part A) down on a soft flat surface, such as carpet, as shown below. Attach back panel (part B) to arm panel (part A) using medium bolts (part #2), washers (part #5), nuts (part #4), wrench (part #6) and allen key (part #7).

NOTE: Please do not fully tighten bolts until unit is fully assembled.

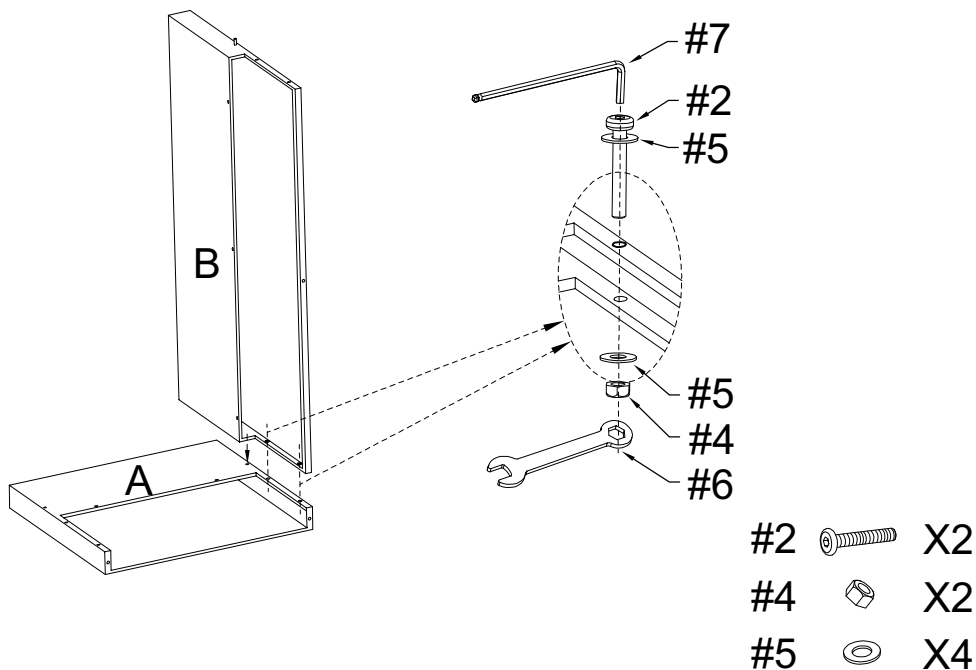

Step 2. Attach seat panel (part C) to arm panel (part A) and back panel (part B) using long bolts (part #3), washers (part #5), nuts (part #4), wrench (part #6) and allen key (part #7).

NOTE: Please do not fully tighten bolts until unit is fully assembled.

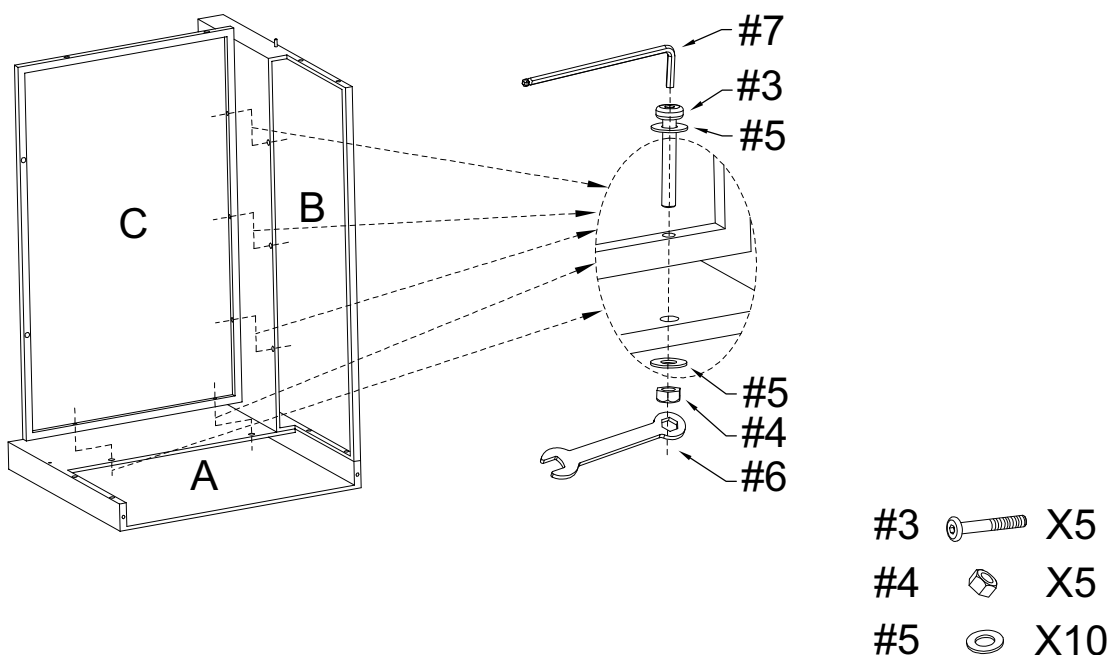

Step 3. Attach lower front (part D) to arm panel (part A) and seat panel (part C) using short bolts (part #1), long bolts (part #3), washers (part #5), nuts (part #4), wrench (part #6) and allen key (part #7).

NOTE: Please do not fully tighten bolts until unit is fully assembled.

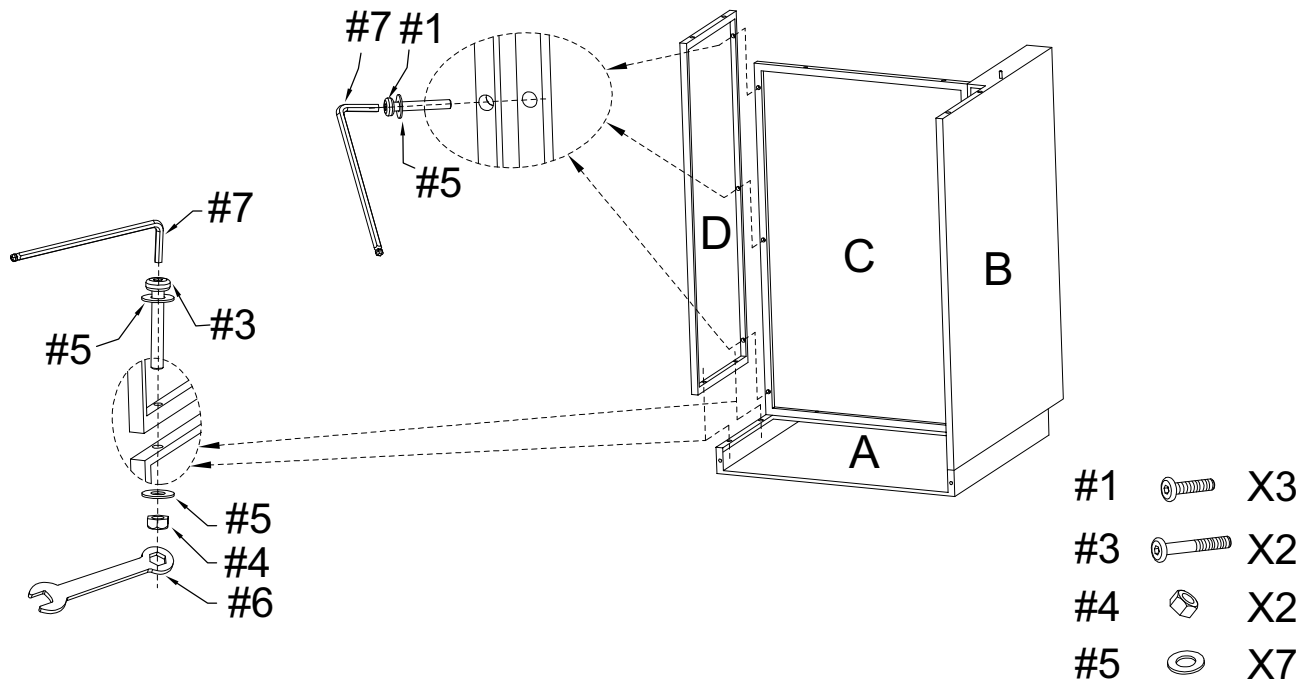

Step 4. Attach arm panel (part A) to assembled unit (parts A,B,C&D) using medium bolts (part #2), long bolts (part #3), washers (part #5), nuts (part #4) wrench (part #6) and allen key (part #7) as shown.

NOTE: Please fully tighten all bolts at this time.

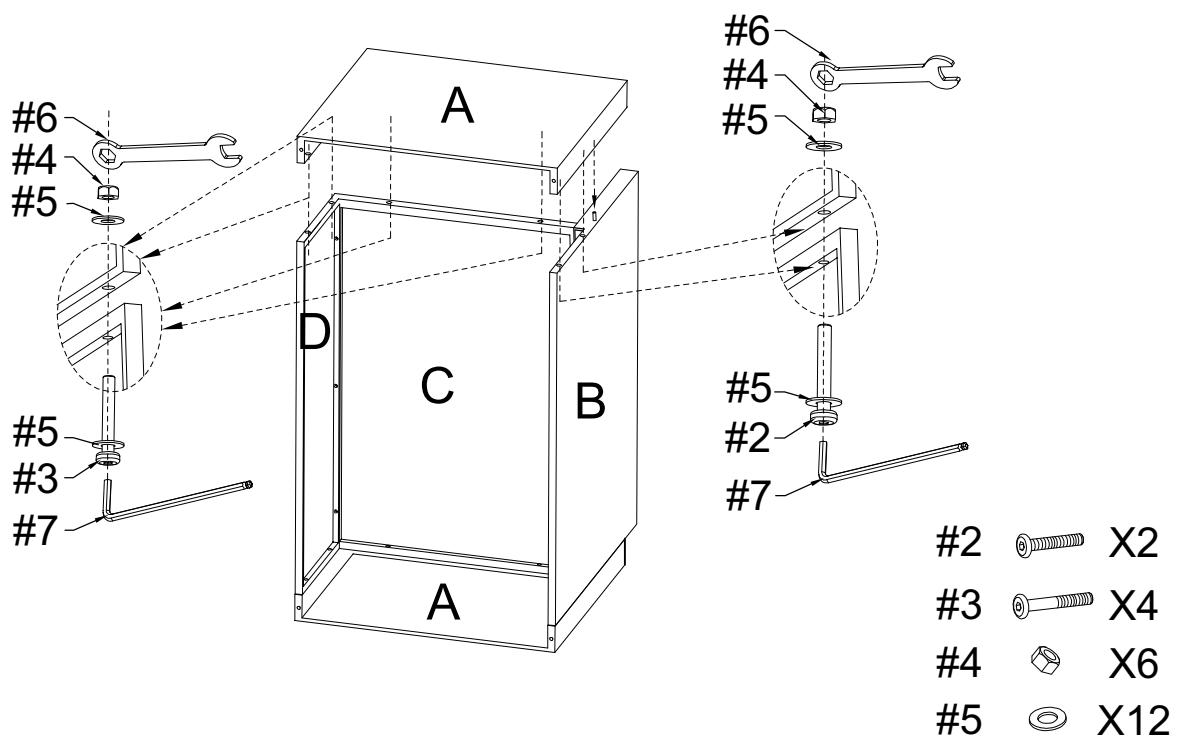

Step 5. Screw adjustable levelers (part #8) to desired position in the pre-drilled holes on the bottom of the sofa where shown.

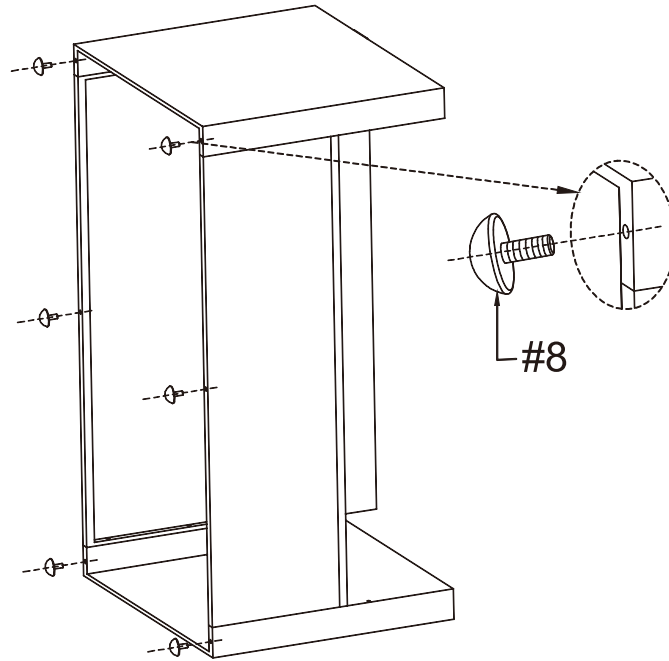

#8  X6

Step 6. Insert core of seat cushion (part F) into cover of seat cushion (part E).
Insert core of back cushion (part H) into cover of back cushion (part G).

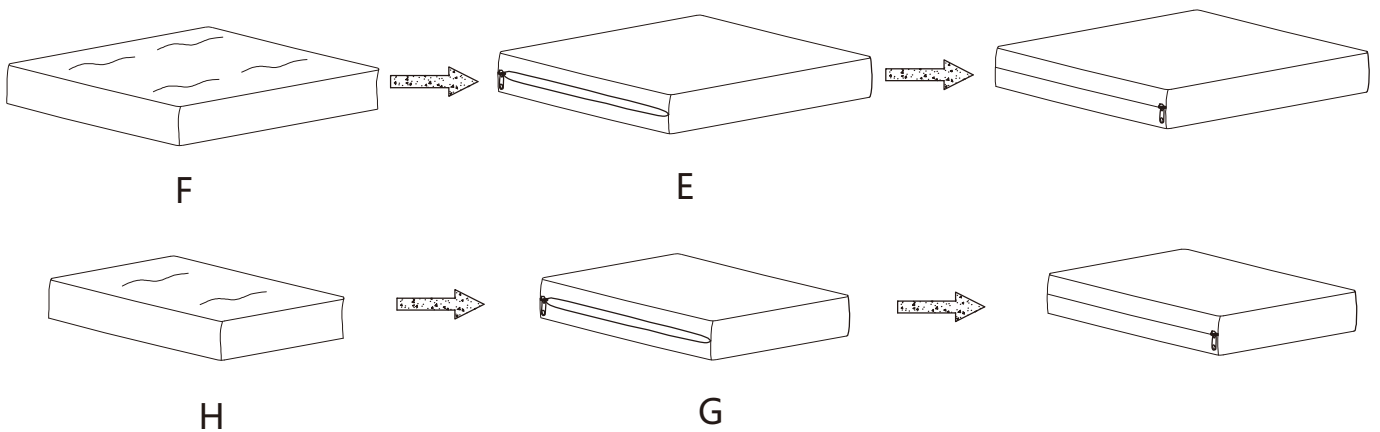

Step 7. Carefully turn the assembled sofa upright and add cushions as shown below.

