

# **SHELTON**

**AIR HOCKEY**



Warning

Adult Assembly Required

Asamblea de adultos de advertencia necesaria



MODEL # / No. de Shelton

**#26-4660**

Assembly and Instructions/Asamblea e Instrucciones

## **Congratulations!**

**We hope you will have many hours of enjoyable use with your new Air Hockey Table!**



### **PLEASE KEEP YOUR INSTRUCTIONS!**

- Your Model number is necessary should you need to contact us.
- Please read through this instruction book to familiarize yourself with all the parts and assembly steps.
- Refer to the Parts Identifier and verify that all parts have been included.



### **WARNING!**

This is not a child's toy. Adult supervision is required for children playing this game. Please read instructions carefully. Proper use of this set can avoid damage or injury.



### **BEFORE ASSEMBLY:**

- Did you receive   1   box?
- Did you inspect your playfield/main table frame before assembly? It is not replaceable and must be returned to the original place of purchase if damaged.



### **TOOLS REQUIRED FOR ASSEMBLY:**



- Phillips and Slotted Head Screwdrivers / or Power Driver (not included)
- Allen Wrench (included)

## **ASSEMBLY INSTRUCTIONS:**

**We recommend that two adults work together to assemble this table.**

- The table will be assembled upside down. This is a very heavy table and turning it right side up will require at least two strong adults.
- We suggest that you use the bottom carton as a clean flat work area to protect the top of your Air Hockey table while assembling.

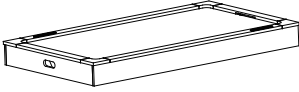
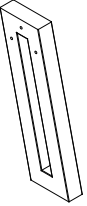
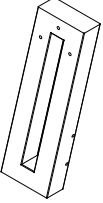
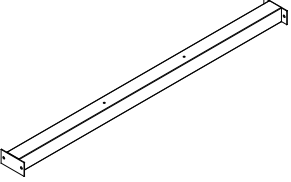
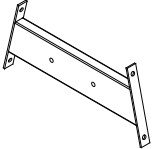
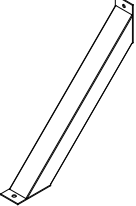
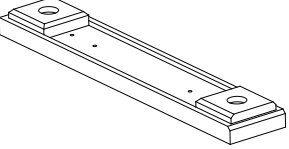
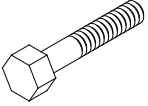
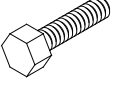
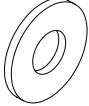
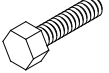
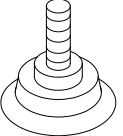
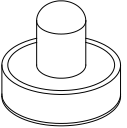
# Parts List

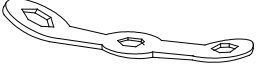
<p>#1</p>  <p>Main cabinet 1 piece</p>	<p>#2</p>  <p>Left leg 2 pieces</p>	<p>#3</p>  <p>Right leg 2 pieces</p>	<p>#4</p>  <p>Cross bar 1 piece</p>
<p>#5</p>  <p>Leg panel 2 pieces</p>	<p>#6</p>  <p>Metal Support 2 pieces</p>	<p>#7</p>  <p>Foot 2 pieces</p>	<p>#8</p>  <p>5/16"X2" Bolt 8 pieces</p>
<p>#9</p>  <p>5/16"X1-1/2" Bolt 14 pieces</p>	<p>#10</p>  <p>5/16" X19mm Washer 36 pieces</p>	<p>#11</p>  <p>5/16"X5/8" Bolt 14 pieces</p>	<p>#12</p>  <p>Leg leveler 4 pieces</p>
<p>#13</p>  <p>Pusher 4 pieces</p>	<p>#14</p>  <p>Puck 4 pieces</p>	<p>#15</p>  <p>Wrench 1 piece</p>	

## Step 1:

- Attach Leg Panel (Part #5) to Left and Right Legs (Parts #2 and #3) using six 5/16" x 5/8" Bolts (#11) and six 5/16" Washers (#10). Finger tighten until all bolts are in place.
- Repeat with remaining legs and panel.

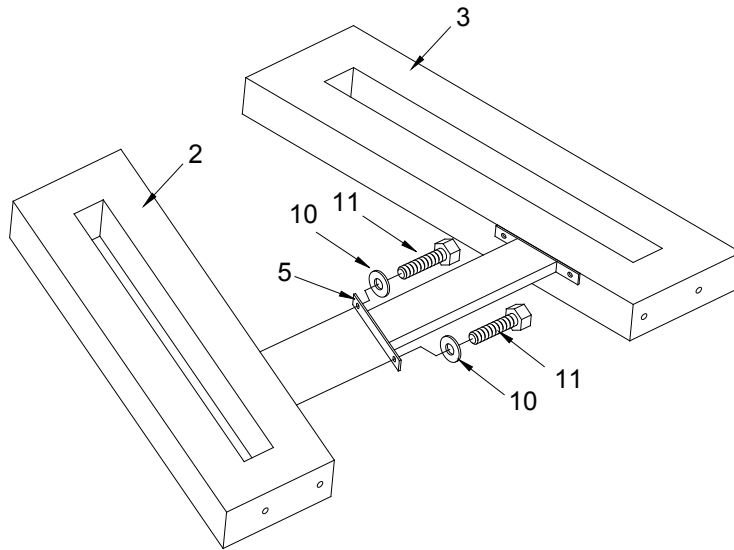

## Step 2:

- Attach one leg to the foot (#7), using 5/16" Bolts (#8) and 5/16" Washers (#10).

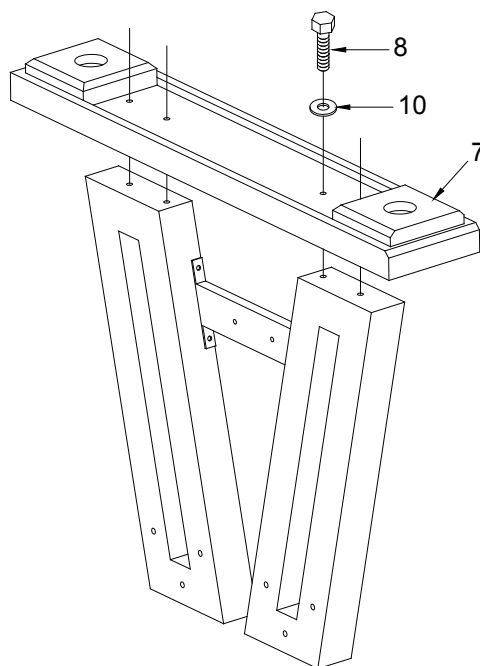

### Step 3:

Attach leg to main cabinet (#1) using 5/16 x 1-1/2" Bolts (#9) and 5/16" Washers (#10). Then screw in #12 leg levelers.

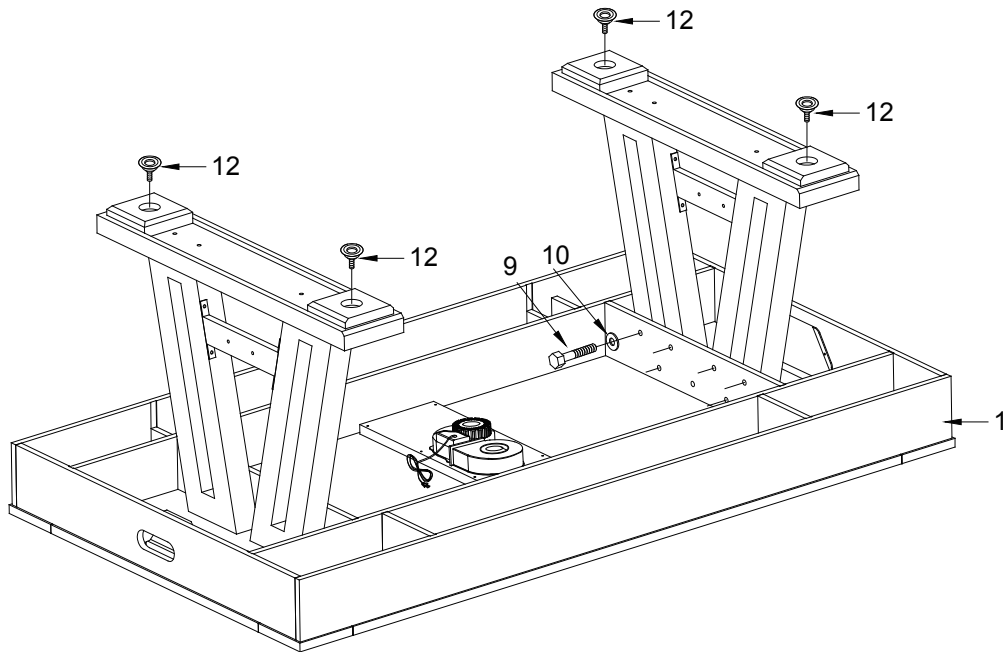

### Step 4:

Attach the legs to the cross bar (#4) using six 5/16 x 5/8" Bolts (#11) and six 5/16" Washers (#10).

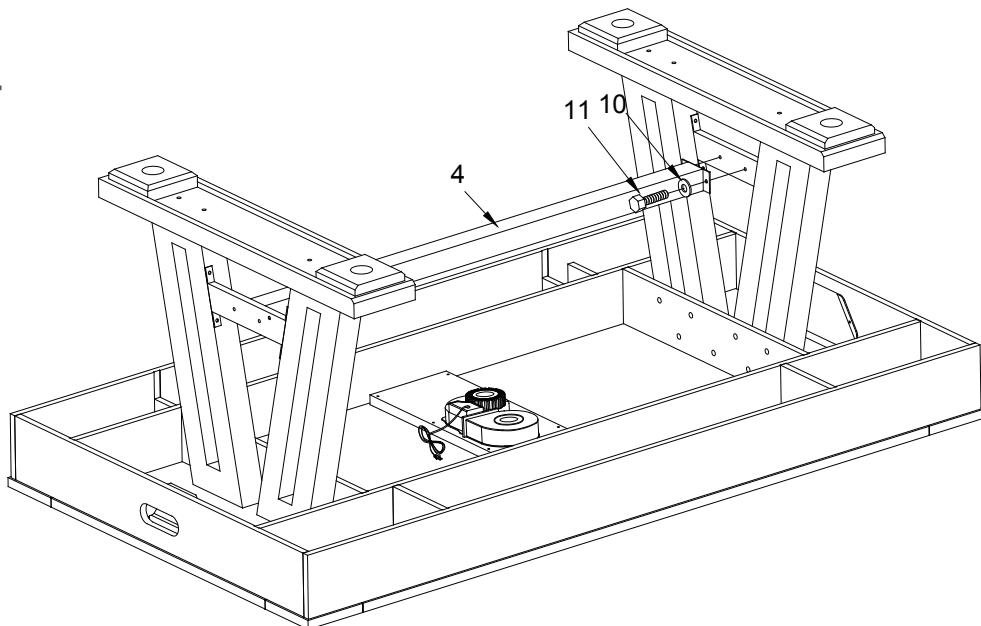

**Step 5:**

Attach Metal Support, using four 5/16 x 5/8" Bolts (#11) and 5/16" Washers (#10).  
using four 5/16 x 1-1/2" Bolts (#9) and 5/16" Washers (#10).

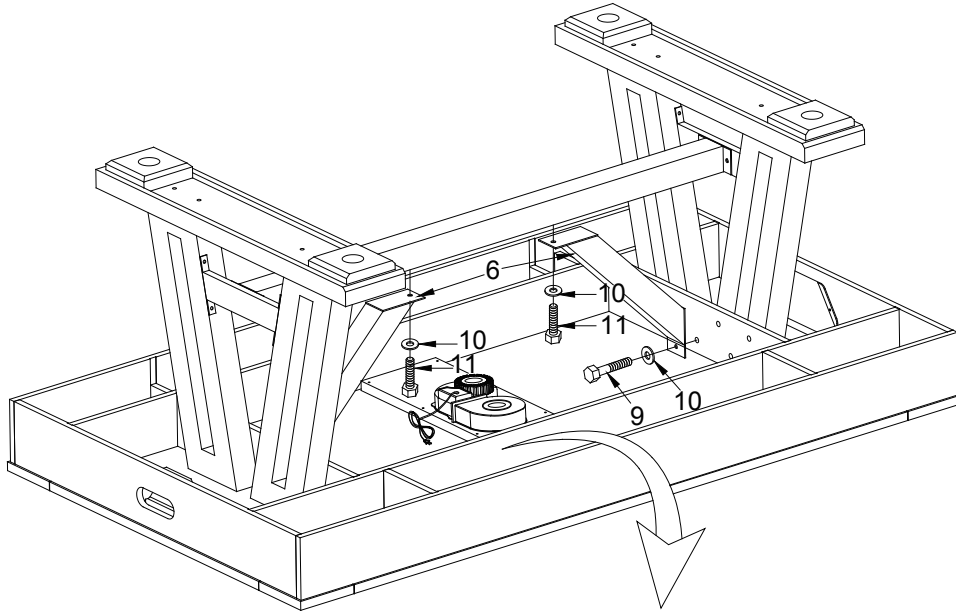

**Step 6:**

Using two strong adults turn the table right side up.

