

Assembly Instructions

Caution: You must read this before you proceed

Please look in the Seat Panel for Hardware Pack

BARSTOOL

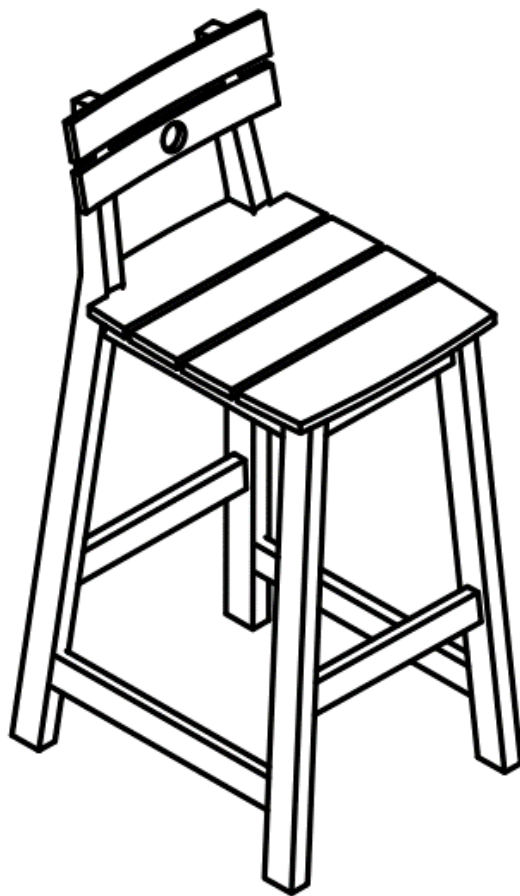

CAUTION: This Barstool is NOT a TOY.



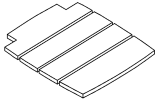
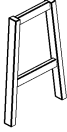
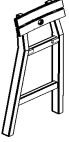
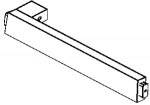
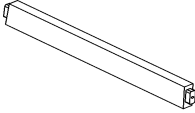

Keep your child / children at bay during the assembly process.

For turning the Barstool and to prevent damage to the Barstool, 2 people may be needed to execute this action.

Parts List

Label	Picture	Description	QTY
A		Seat Panel	1
B		Front Leg Frame	1
C		Back Leg Frame	1
D		Short Support Bar	2
E		Long Support Bar	2

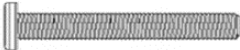
Hardware

Label	Picture	Description	QTY
①		Screw (M6x35mm)	3
②		Screw (M6x65mm)	7
③		Bolt (M6X60mm)	3
④		Allen Wrench	1

Assembly Preparation

Before Beginning Assembly:

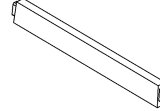
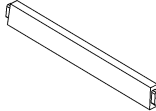
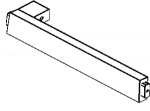
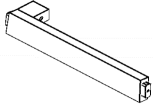
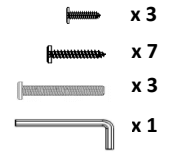
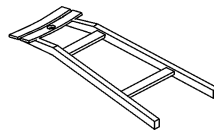
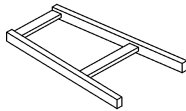
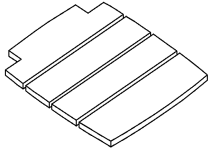

- Read instructions, cover to cover-



- Have 2 adults on hand for assembly-



- Do not assemble on flooring or carpet-



- Assemble on a clean non-marring surface (packing foam)-



- Save all packaging until finished-

Assembly Steps

Overview

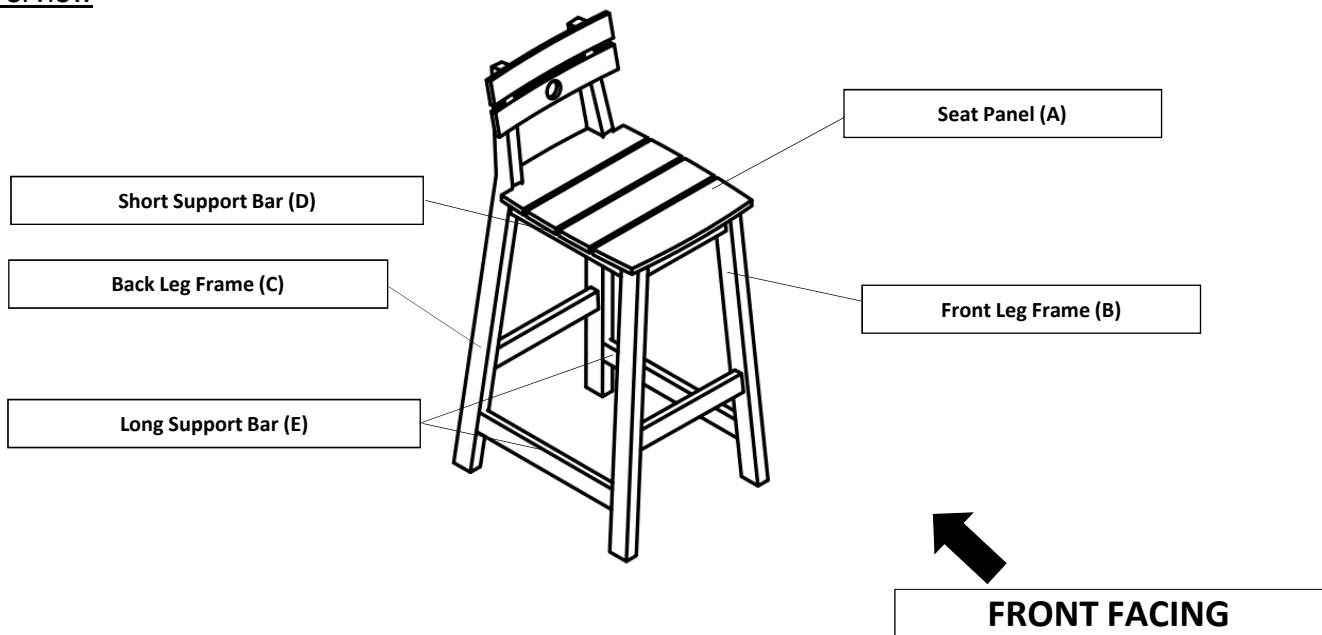

This Barstool has multiple parts and may require up to 30 minutes to assemble. To give you an overview of the Barstool, the above picture is to help you put the various parts into perspective. Please read through the instructions below to familiarise yourself with the parts and steps before assembly.

Step 1

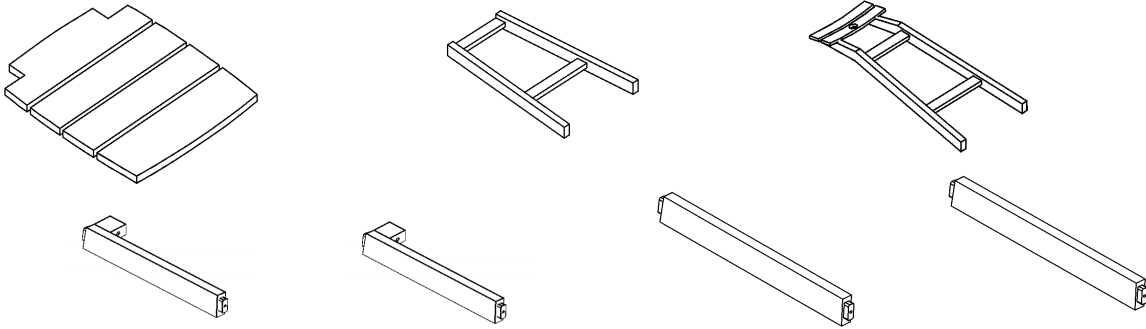

Unpack and place all parts on a clean, non-marring surface.

Step 2

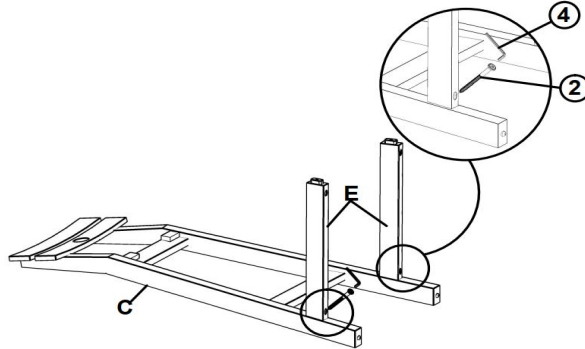

With assistance from your adult partner, position the Long Support Legs(E) into the Back Leg Frame(C) as shown in above picture.
Then using Screws(②) and the Allen Wrench(④), secure the Long Support Legs(E) to the Back Leg Frame(C).
Do not fully tighten the Screws.

Step 3

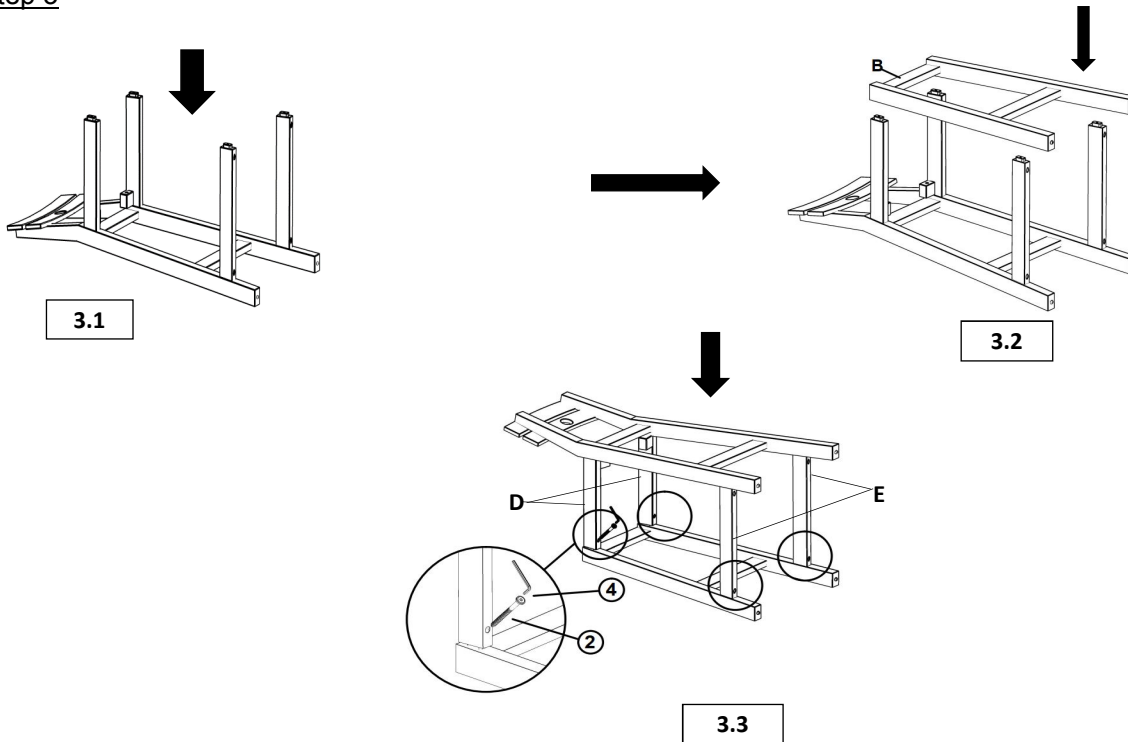

With assistance from your adult partner,
3.1) Position the Short Support Legs(D) to the assembled part in Step 2.
3.2) Position Front Leg Frame(B) to the assembled part in Step 3.1 and turn the Barstool onto the opposite side as shown in the above picture.
3.3) Secure the Short Support Legs(D) and the Long Support Legs(E) onto the Front Leg Frame(B) using Screws (②) and the Allen Wrench(④) as shown in the above picture.
Do not fully tighten the Screws.

Step 4

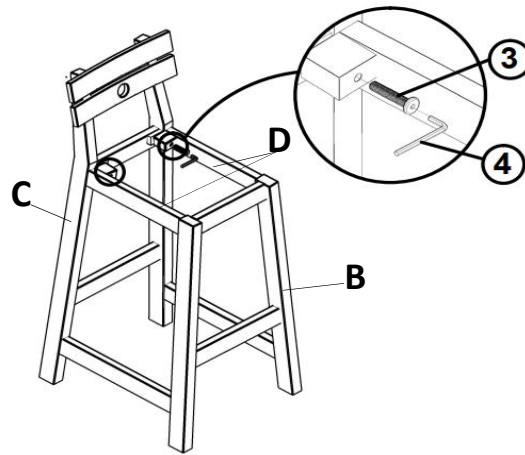

With assistance from your adult partner, turn the Barstool right side up as shown in above picture. Then using Bolt(③) and the Allen Wrench(④), secure the Short Support Legs(D) to the Back Leg Frame(C). Do not fully tighten the Bolts.

Step 5

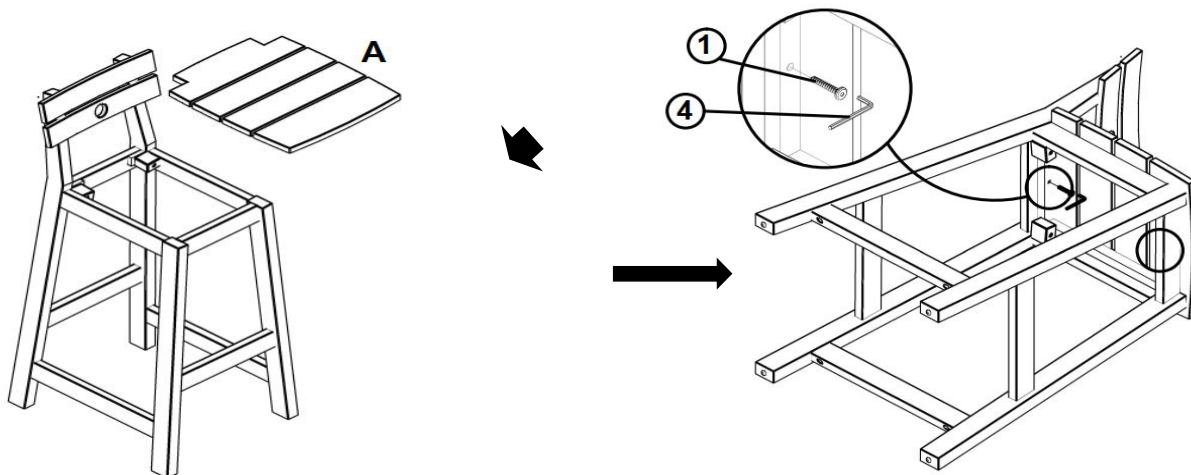

Attach the Seat Panel(A) onto the assembled part in Step 4 as shown in the above picture. With assistance from your adult partner, lay down the Barstool as in the above picture, then use the Screws(①) and the Allen Wrench(④) to secure the Seat Panel(A) to the Front Leg Frame(B) and the Back Leg Frame(C). Do not fully tighten the Screws.

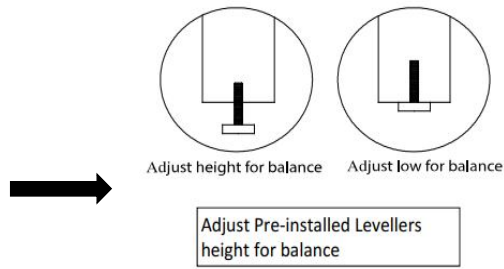

With assistance from your adult partner, turn the Barstool right side up.

Inspect it and make sure all parts are adequately connected.

Carefully sit onto the Barstool. This pressure will help align all parts at all joints.

Then get off the Barstool and proceed to tighten the Bolts and Screws in a sequential manner.

When tightening the Bolts and Screws tighten sequentially.

DO NOT tighten any Bolt and Screw fully and then move on towards the next one.

If there are any wobbles after tightening, loosen the Bolts and Screws and execute this same process.









Adjust the Levellers until the Barstool is level with the ground.

To adjust the Levellers, get assistance from an adult partner to lift/lean and hold the Barstool while you are working.

Your Barstool is ready for use.

This Barstool can only be used on a flat, level surface.

Care & Maintenance

- ⊗  ● Do not put hot items directly on furniture surface.
- ⊗  ● Do not clean furniture with harsh cleansers or polish.
- ✓  ● To obtain the longest lifespan of your outdoor products, minimizing exposure to direct sunlight is recommended.
- ⊗  ● Children should not climb or jump on the furniture.
- ⊗  ● Do not write on furniture without a padded barrier to protect the surface.
- ✓  ● To obtain the longest lifespan of your outdoor products, avoid extended and lengthy exposure to rain, snow, and direct sunshine. Whenever possible cover the product and /or place under patio or awnings.
- ⊗  ● Not for commercial use. For residential use only.
- ⊗  ● Stains may be removed with mild soap solution and damp cloth.
- ✓  ● Dust and pick-up spills using a clean, non-colored, lint-free cloth.