

# Console table

---

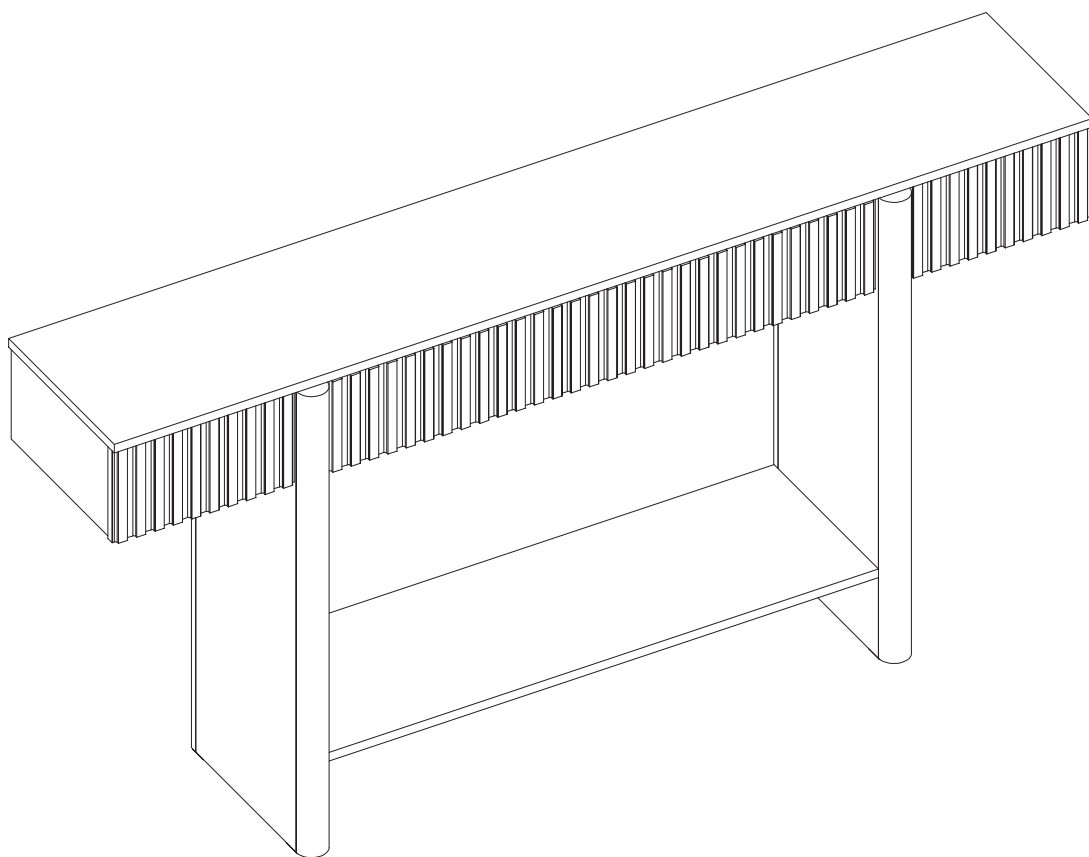

**Suggestion: To make the installation process easier and faster, we recommend that two people work together to install the nightstand**

# INTRODUCTION

Thank you for purchasing our products. Please read the instructions carefully before installation and keep it in a safe place for future reference. If you need any assistance or support, please feel free to contact our customer support team.

# PRECAUTIONS

1. There are many components and accessories in the package. Each component and accessory is labeled with a letter or a number, check carefully before using any of them. Keep them away from children to prevent accidents.
2. Please install the product on a clean and soft underlay (such as carpet or cardboard) to avoid scratching or damaging the surface of the product.
3. The main components of the product is relatively heavy. Please pay attention to safety during installation.
4. The product is not stable during installation. Please do not move it randomly before it is completely installed.
5. If you have any questions during installation, please contact the customer service in time.

**\* PLEASE BE SURE TO FOLLOW THE INSTALLATION STEPS IN THE MANUAL TO AVOID UNNECESSARY LOSSES CAUSED BY IMPROPER INSTALLATION.**

**\* IF YOU NEED FURTHER ASSISTANCE, PLEASE CONTACT THE CUSTOMER SERVICE ONLINE.**

# EXPLIDED

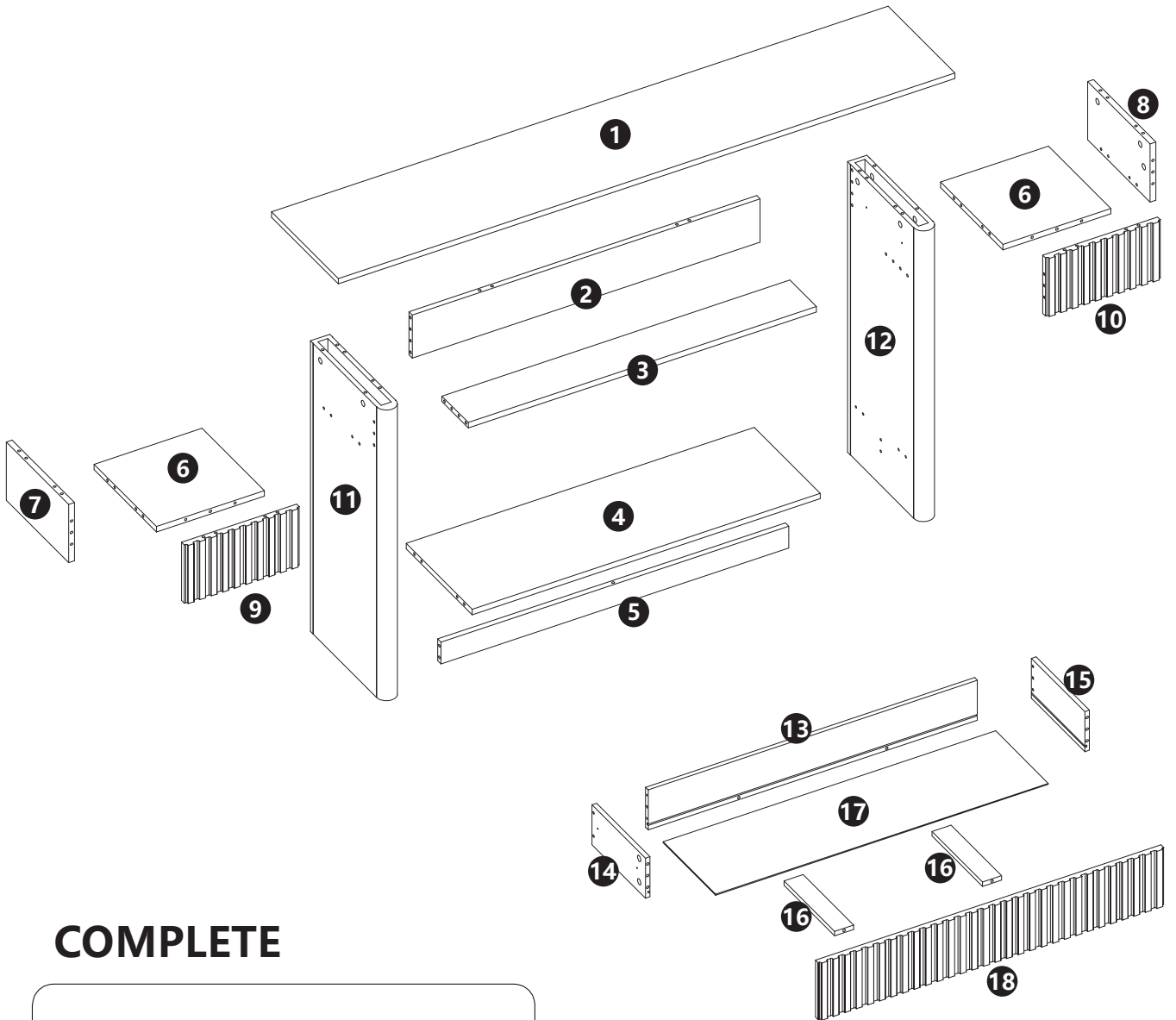

# COMPLETE

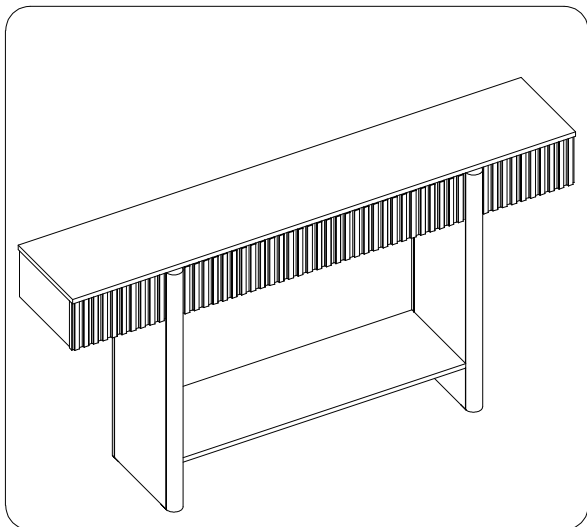

## Parts List

**1 x1**

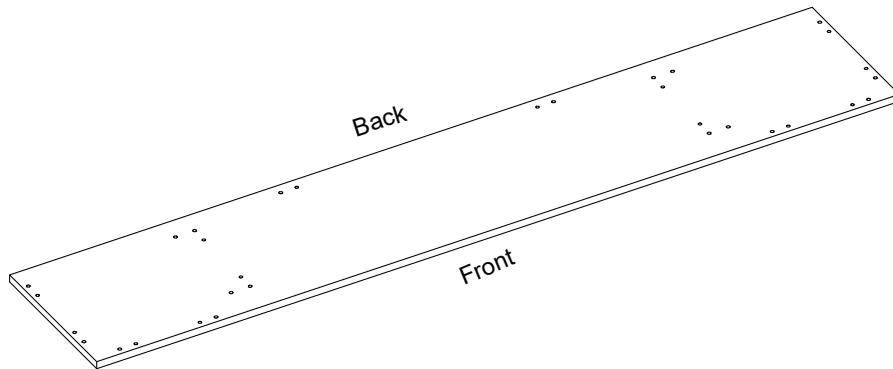

**2 x1**

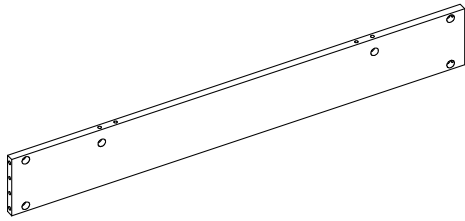

**3 x1**

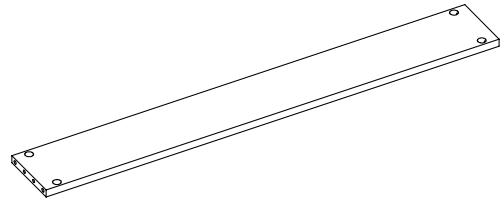

**4 x1**

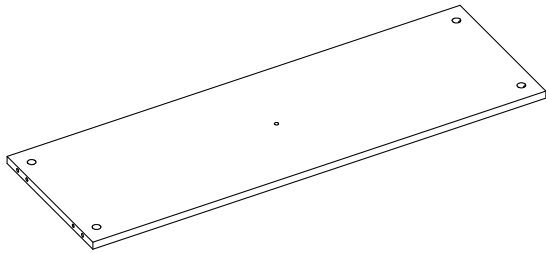

**5 x1**

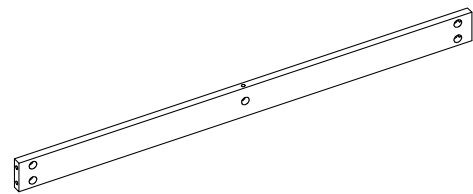

**6 x2**

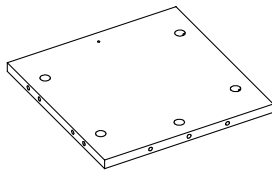

**7 x1**

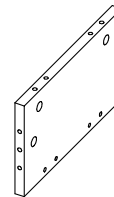

## Parts List

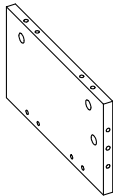
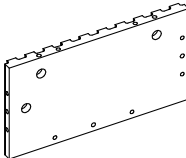
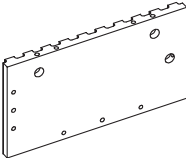
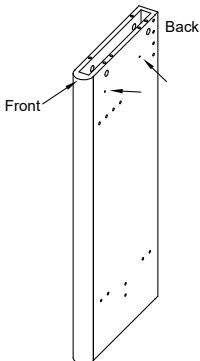
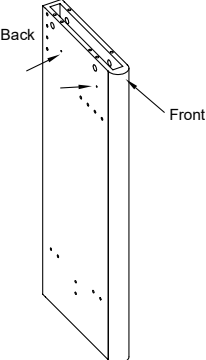
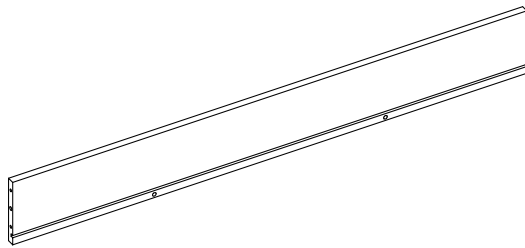
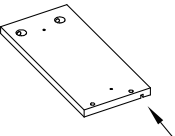
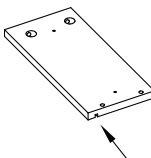
<p><b>8 x1</b></p> 	<p><b>9 x1</b></p> 
<p><b>10 x1</b></p> 	<p><b>11 x1</b></p> 
<p><b>12 x1</b></p> 	<p><b>13 x1</b></p> 
<p><b>14 x1</b></p> 	<p><b>15 x1</b></p> 

## Parts List

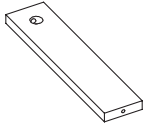
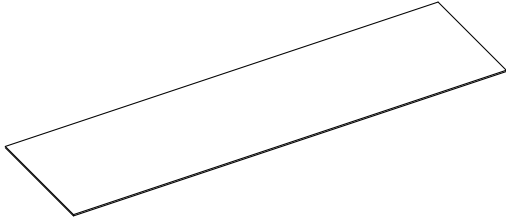
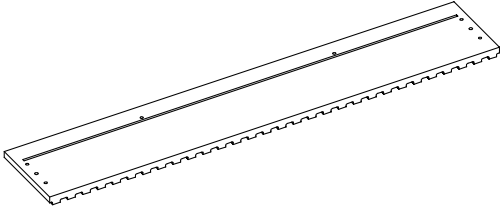
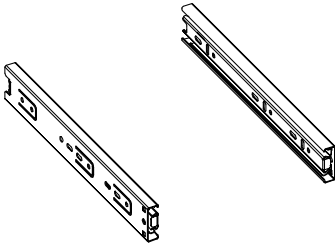

<p><b>16 x2</b></p> 	<p><b>17 x1</b></p> 
<p><b>18 x1</b></p> 	<p><b>19 x1</b></p> 

## Cam Lock Fastening System

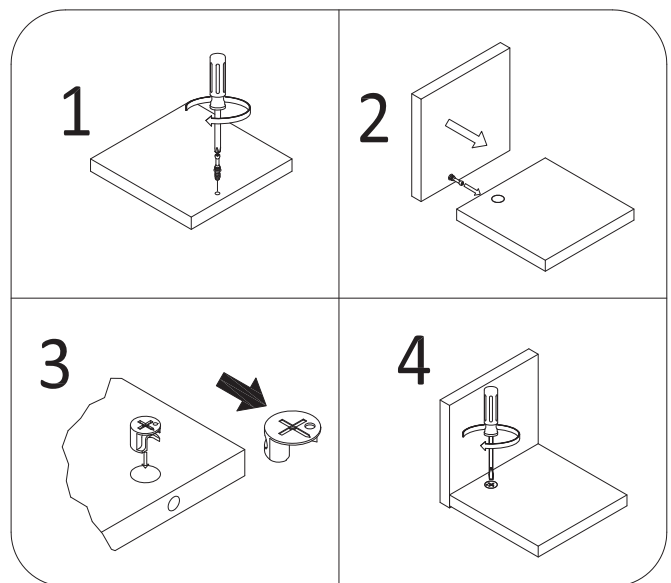
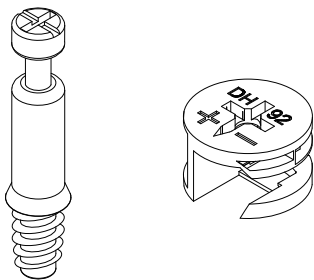
This Cam Lock Fastening System will be used throughout the assembly process

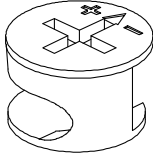
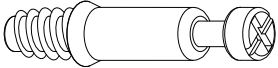
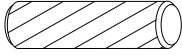
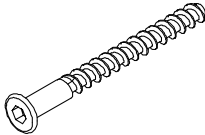
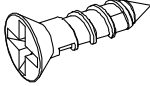
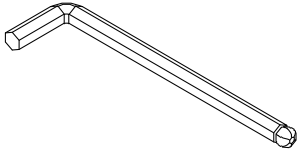

## Parts List

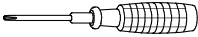
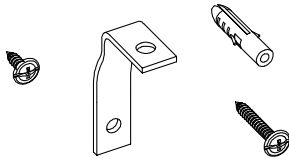
<p><b>A</b> x55+2</p>  <p>Ø15x9.5mm</p>	<p><b>B</b> x55+2</p>  <p>Ø6x35mm</p>	<p><b>C</b> x50+2</p>  <p>Ø6x30mm</p>
<p><b>D</b> x6+1</p>  <p>Ø5x48mm</p>	<p><b>E</b> x8+2</p>  <p>M4x12mm</p>	<p><b>F</b> x1</p> 
<p><b>G</b> x8+2</p> 	<p><b>H</b> x1</p> 	<p><b>I</b> x2</p> 

★ In many cases, we include additional hardware. So after following the assembly instructions, don't worry if there are still extra pieces left over—they're included as a "just in case" for your convenience.

## STEP 1

Before installing the drawer rails, you need to split rail No: 19 into outer rail No: 19-1 and inner rail No: 19-2.

1. Place the rail No: 19 as shown in picture . Then Pull out the No: 19-2

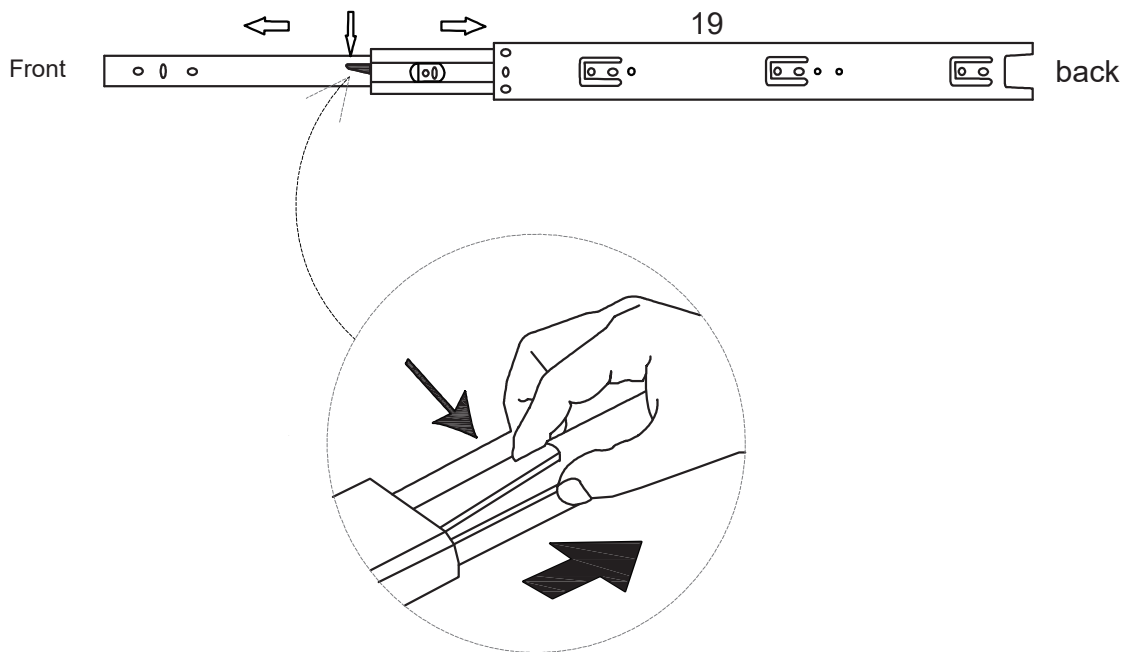

2. Find the latch position, press it and split



## STEP 2

 **E** x4

**Move the balls of the slide rails on both sides to the position as shown in the figure**

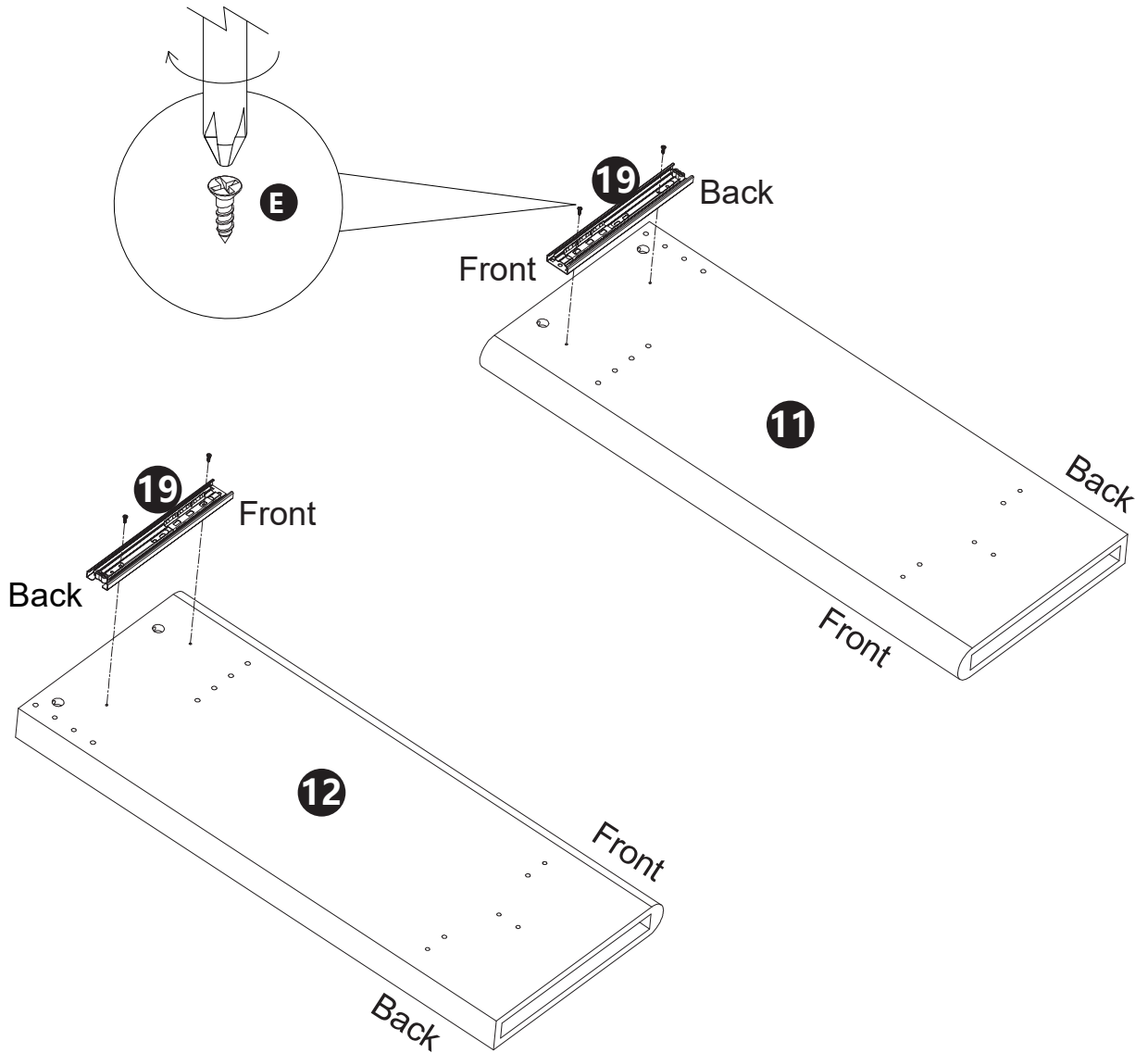
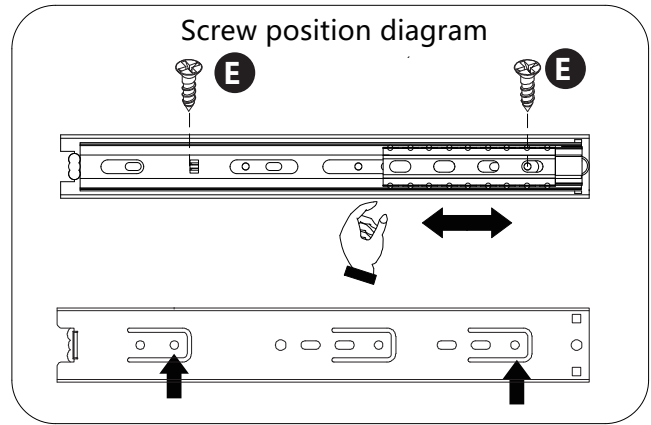

### STEP 3

 **B** x1

 **A** x1

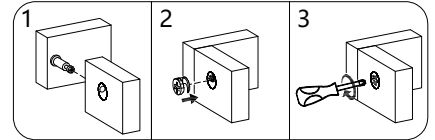
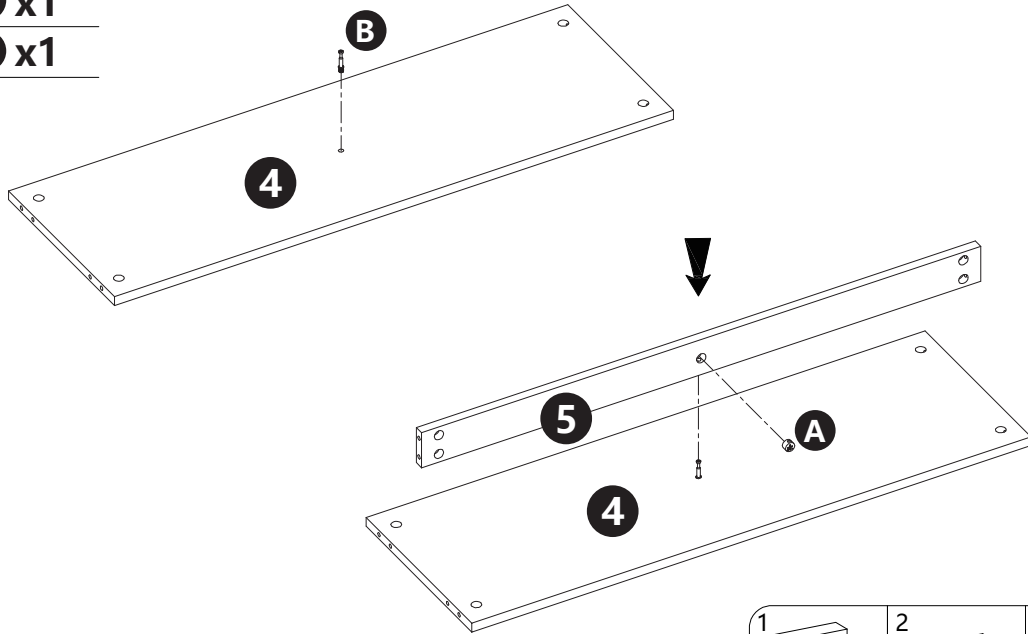

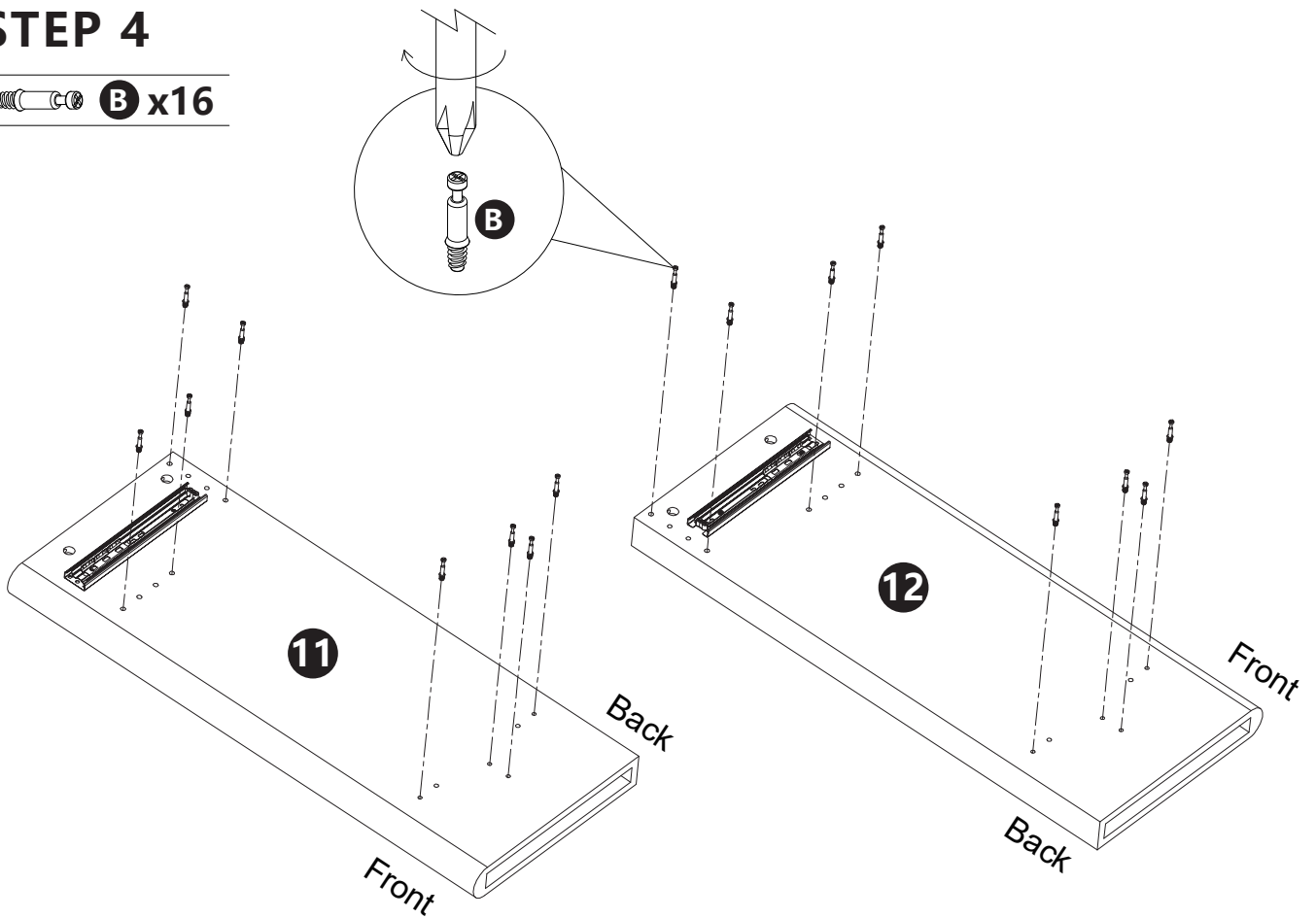

### STEP 4

 **B** x16



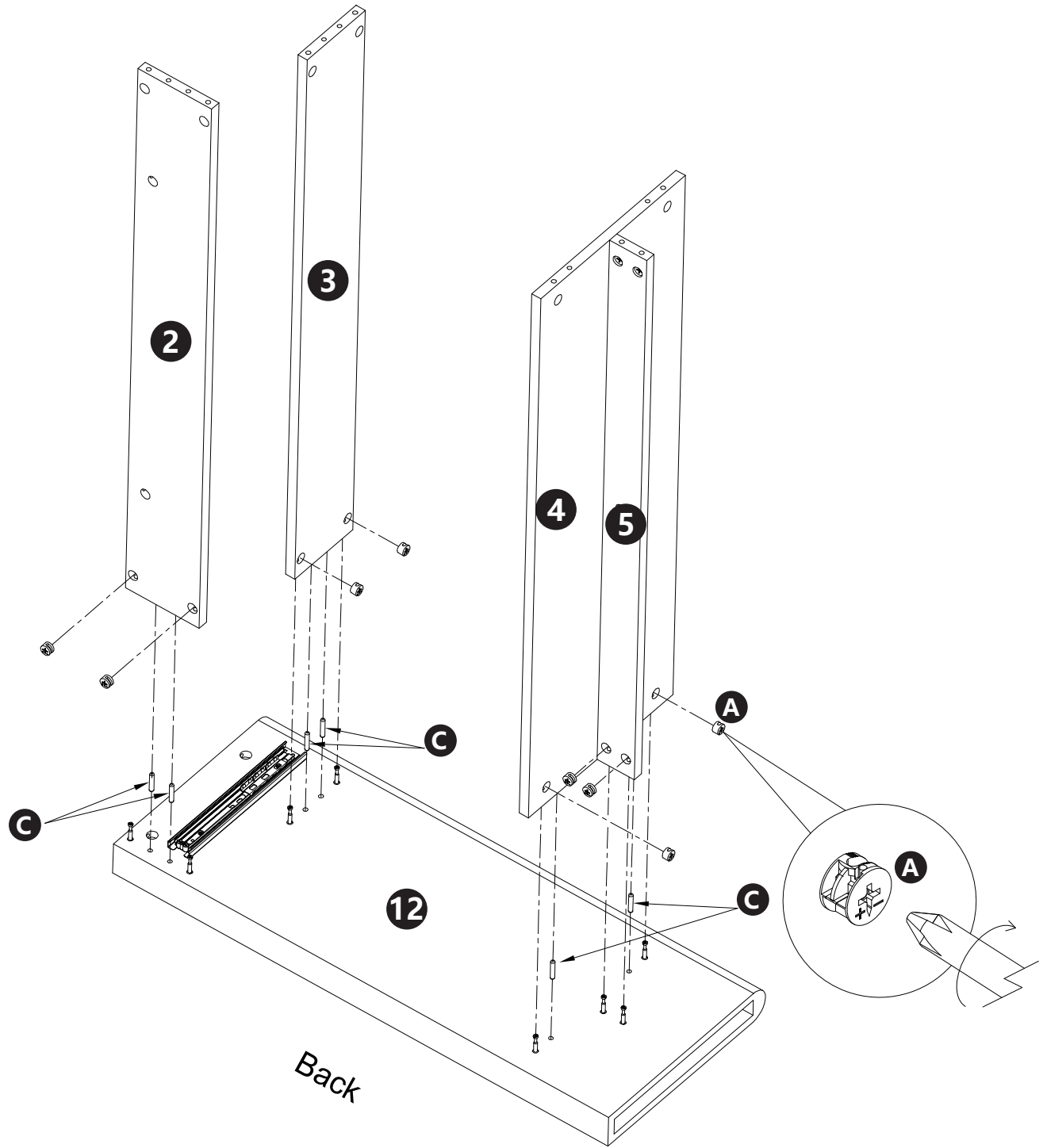

**STEP 5**

-  **A** x8
-  **C** x6



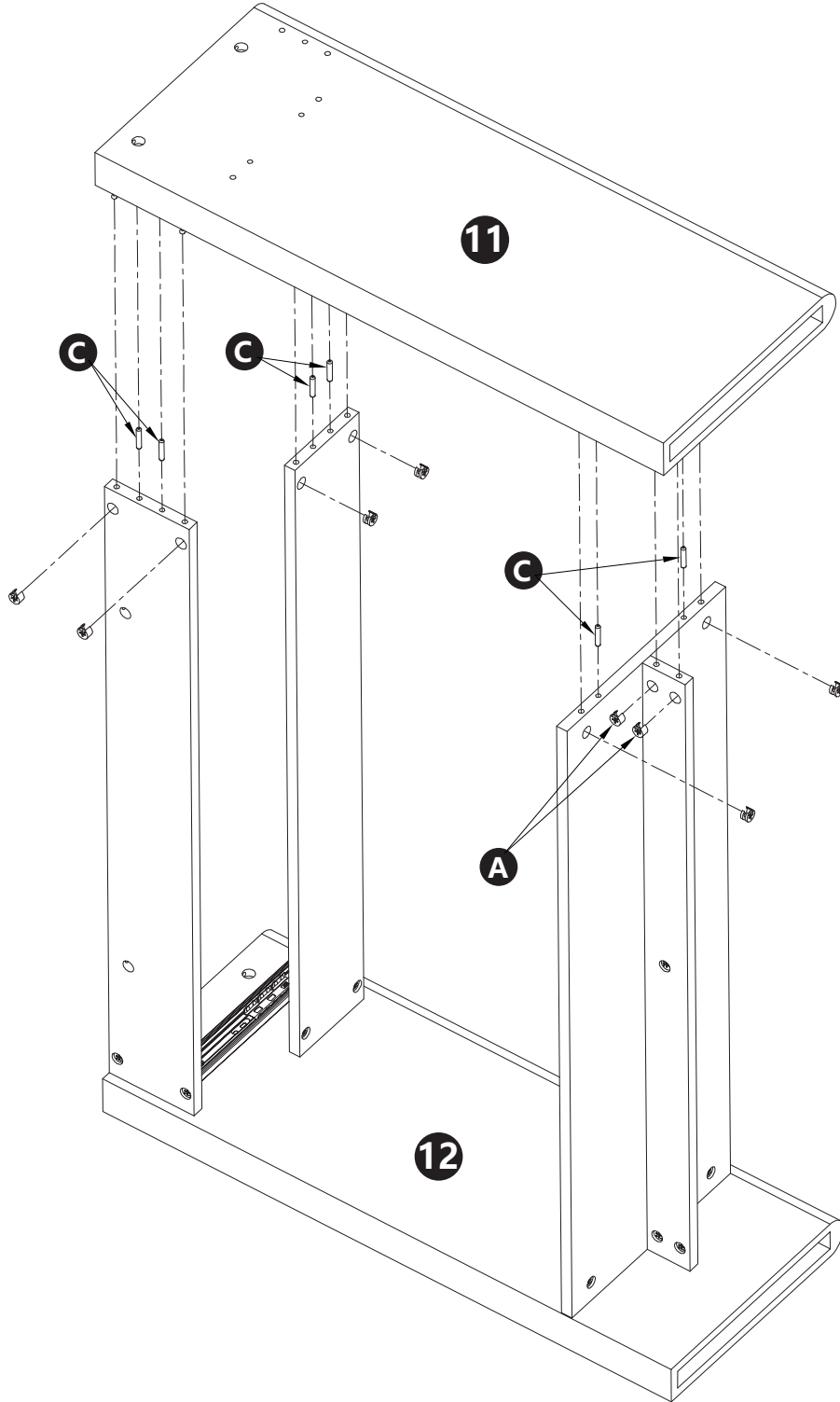

# STEP 6

-  **A** x8
-  **C** x6



**STEP 7**

-  **B** x6
-  **G** x8

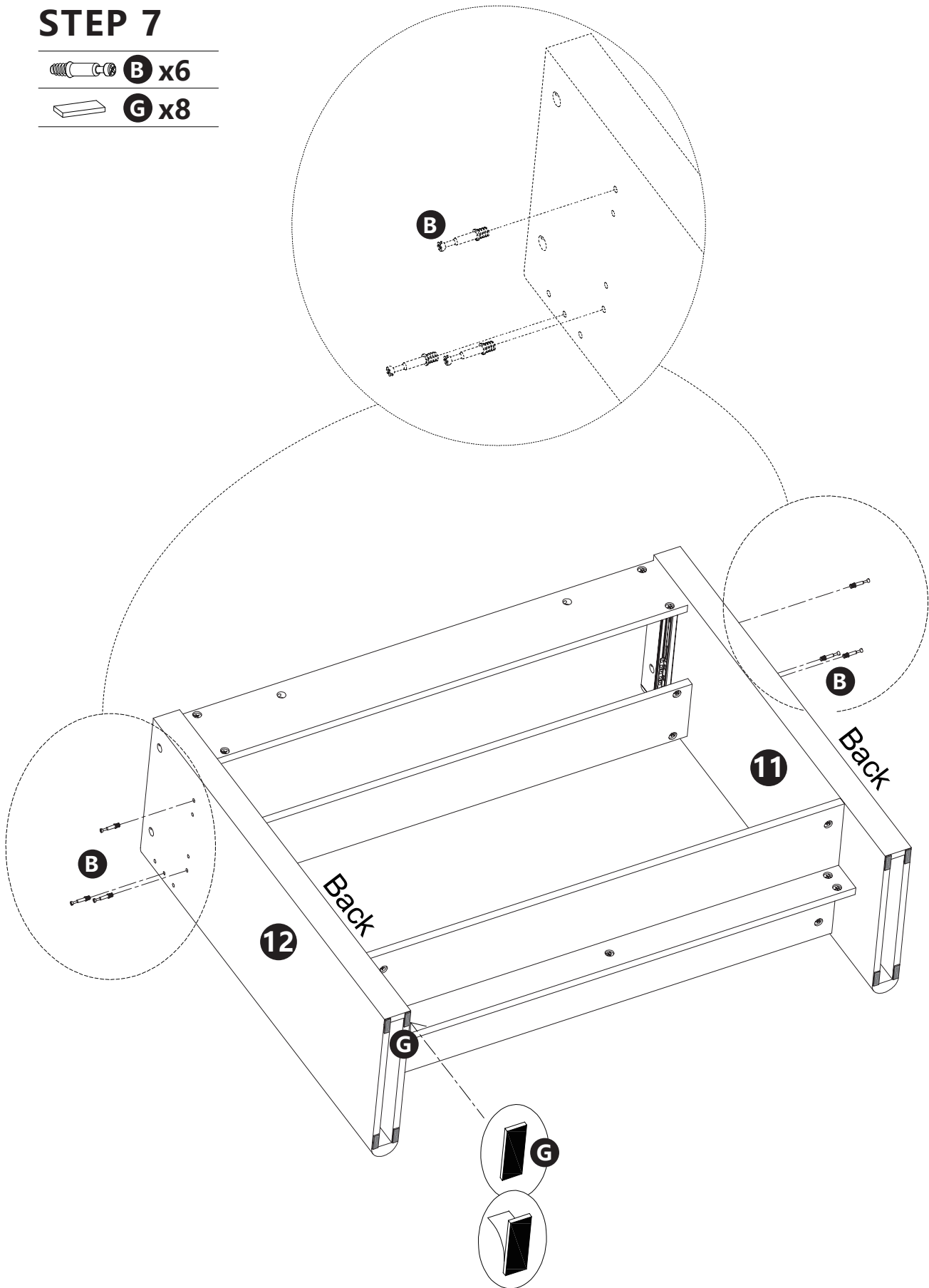

## STEP 8

 **I** x2

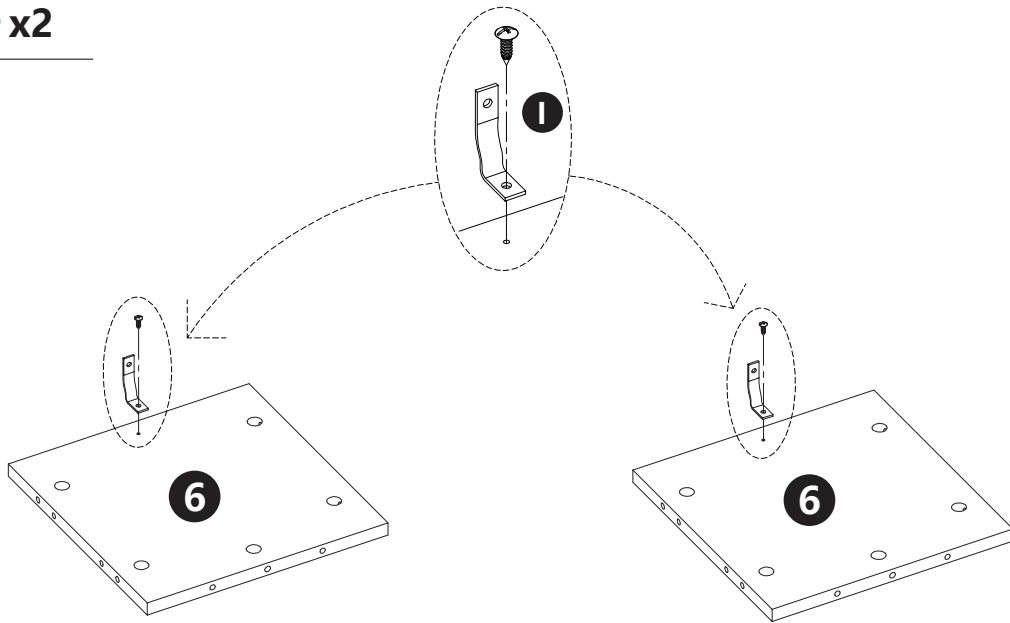

## STEP 9

 **B** x8

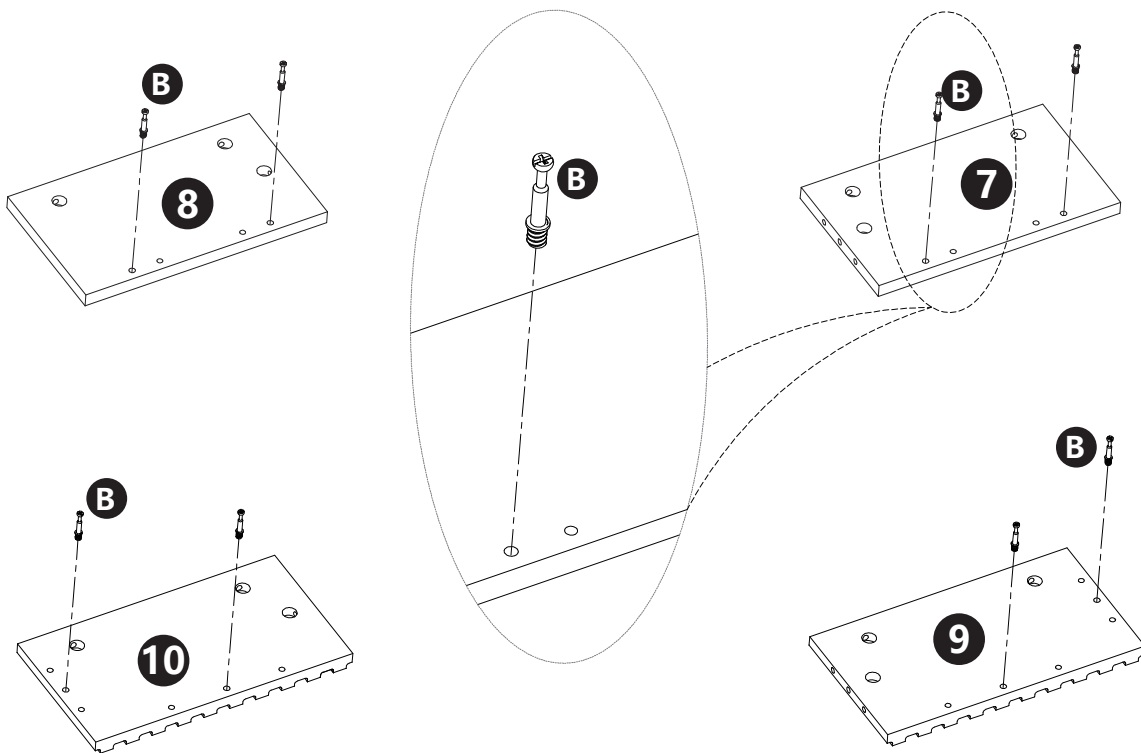

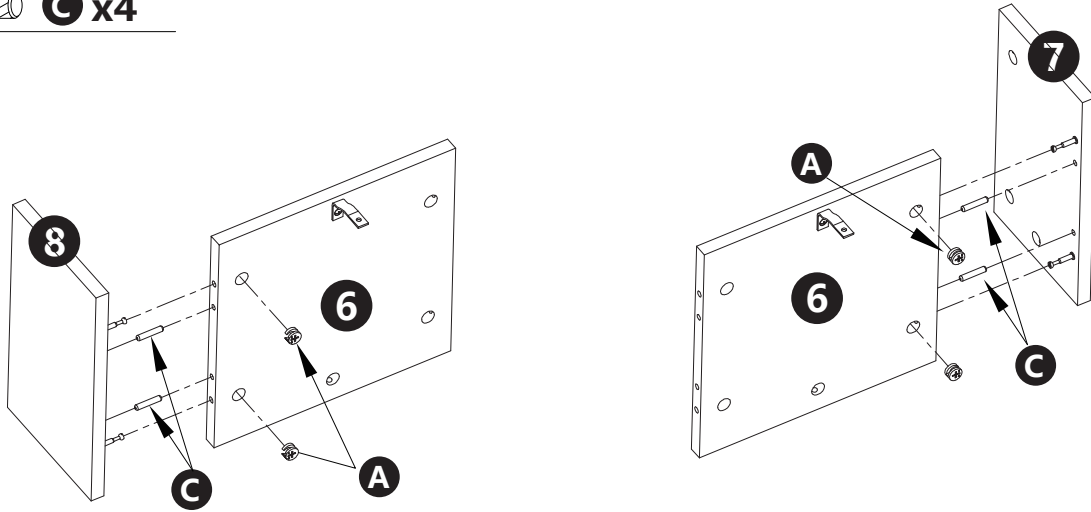
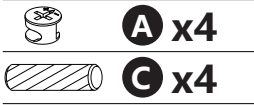

## STEP 10

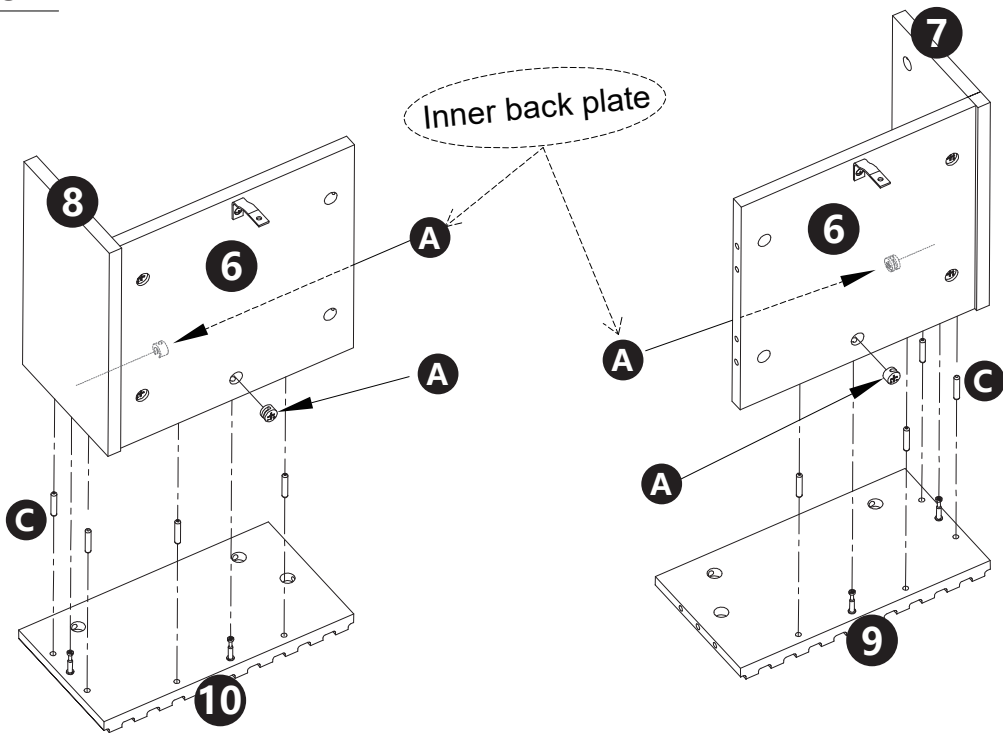
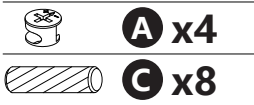

## STEP 11



# STEP 12

-  **A** x6
-  **C** x8

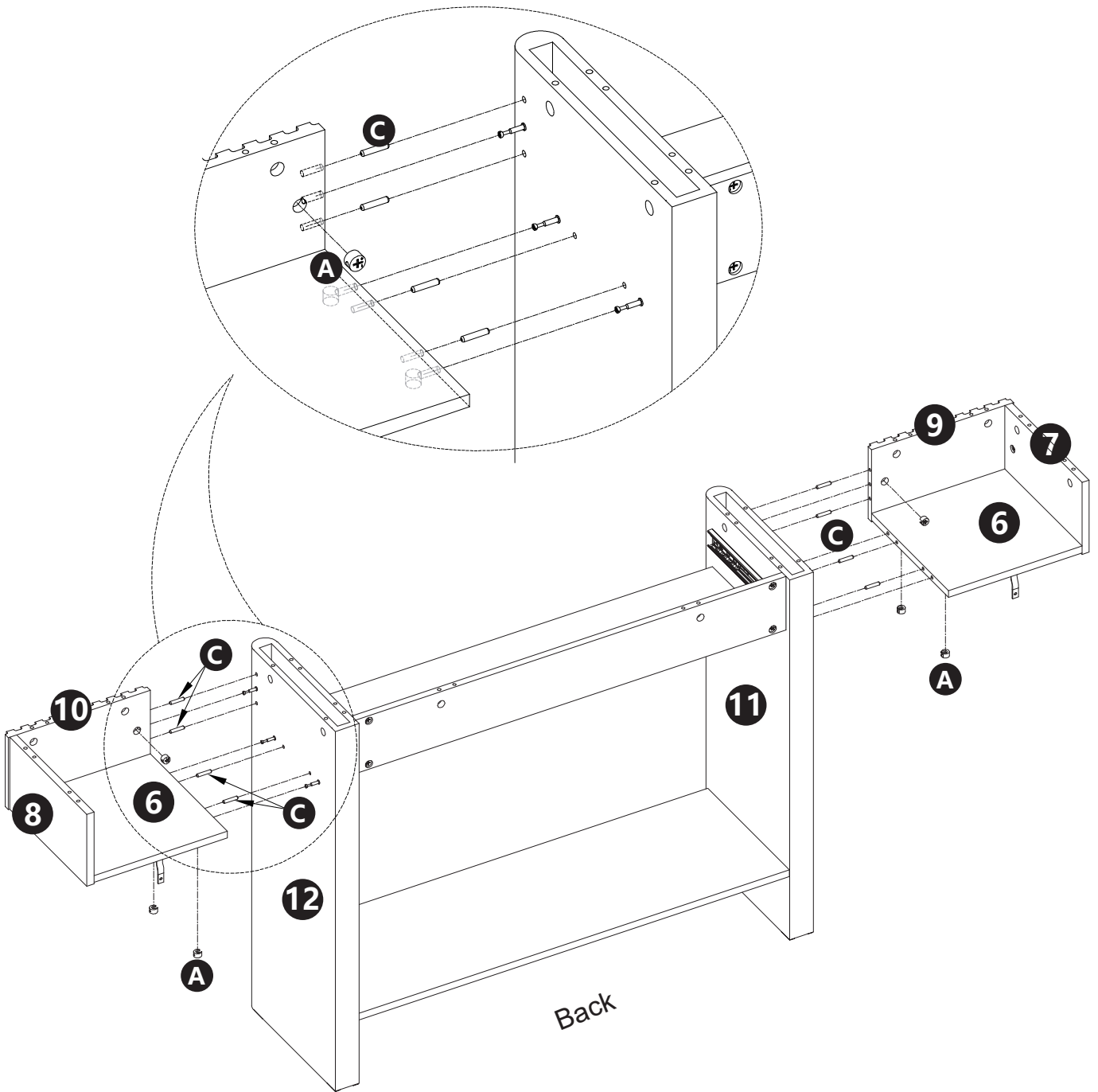

**STEP 13**

 **B** x18

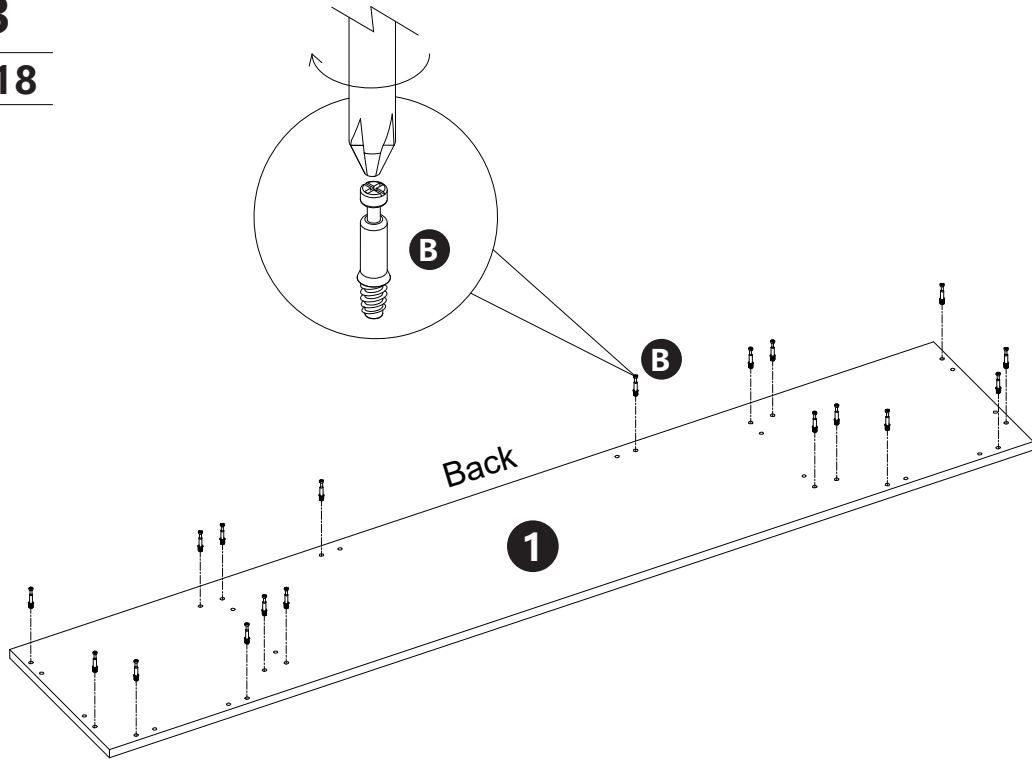

**STEP 14**

 **C** x14

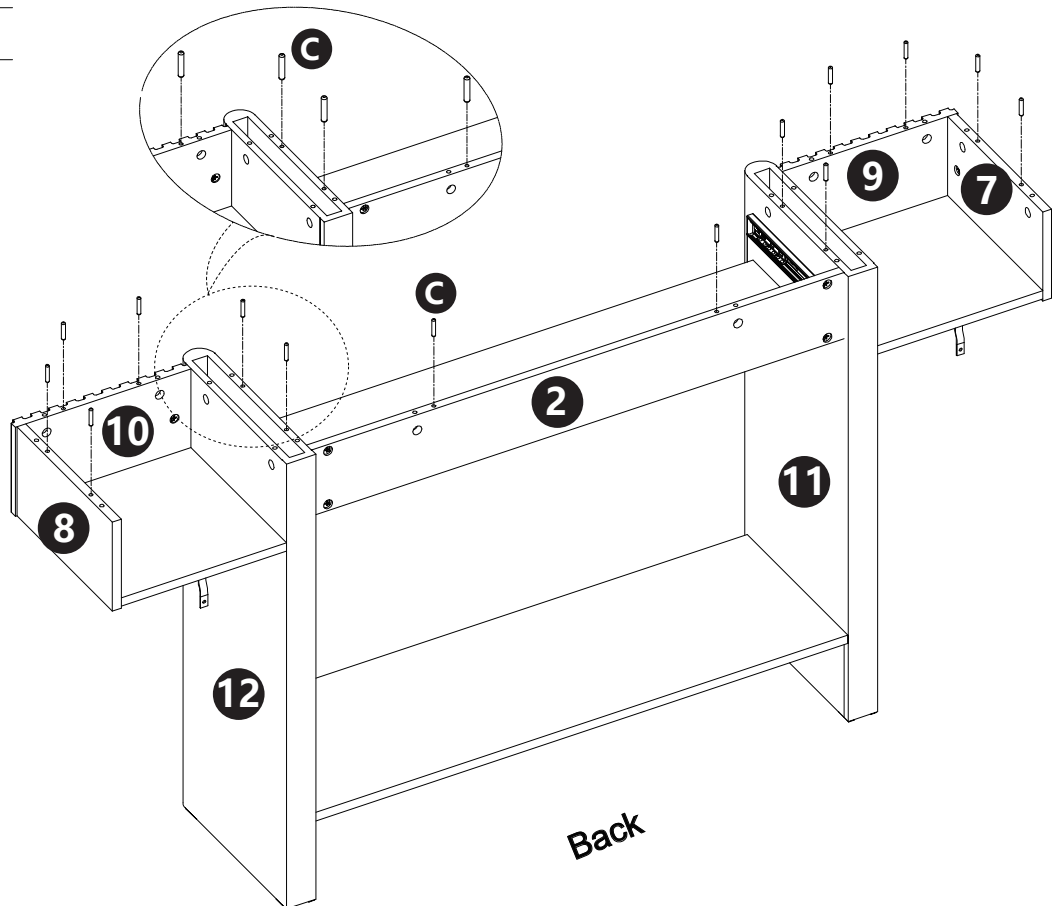

STEP 15



A x18

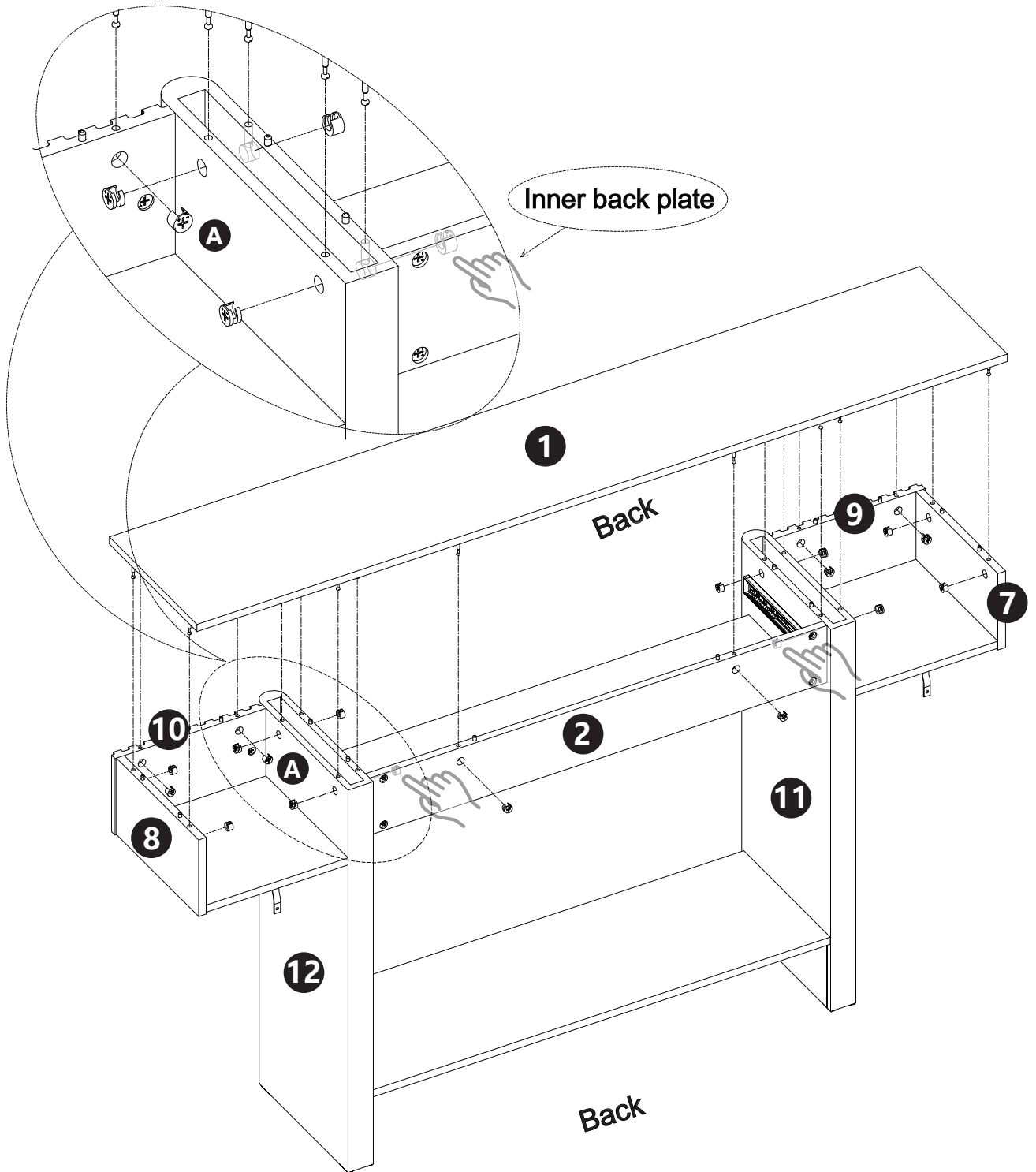

# STEP 16

 **E** x4

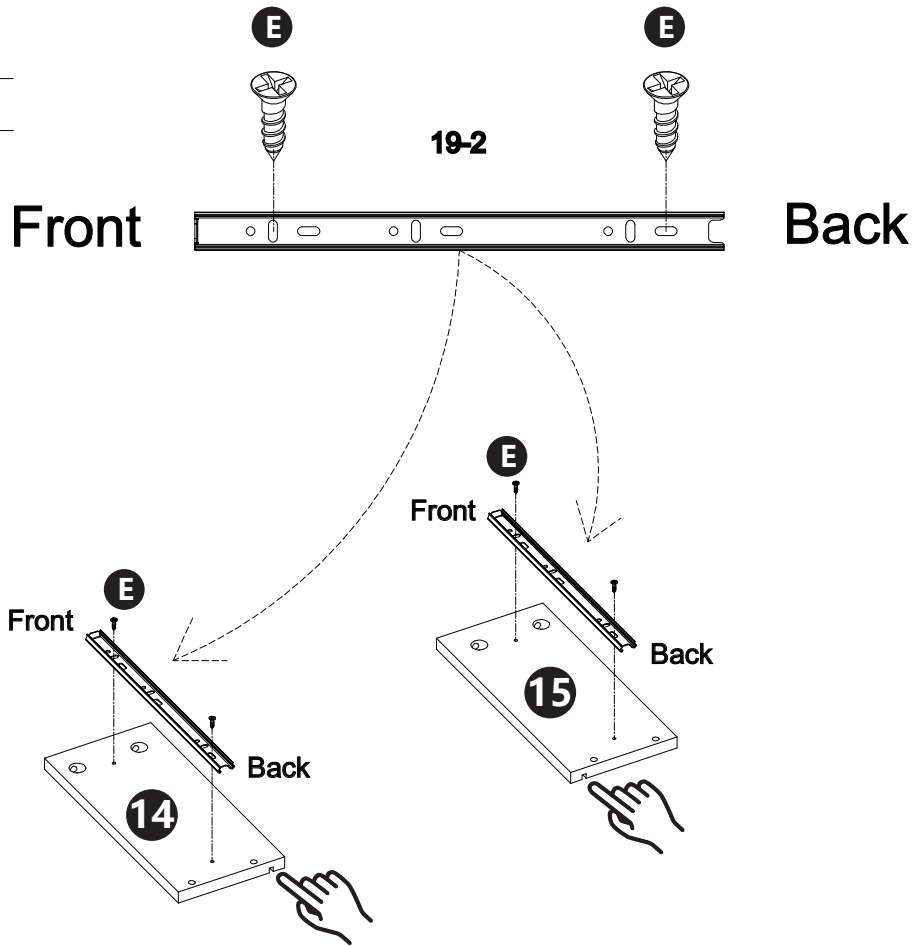

# STEP 17

 **D** x6

 **C** x2

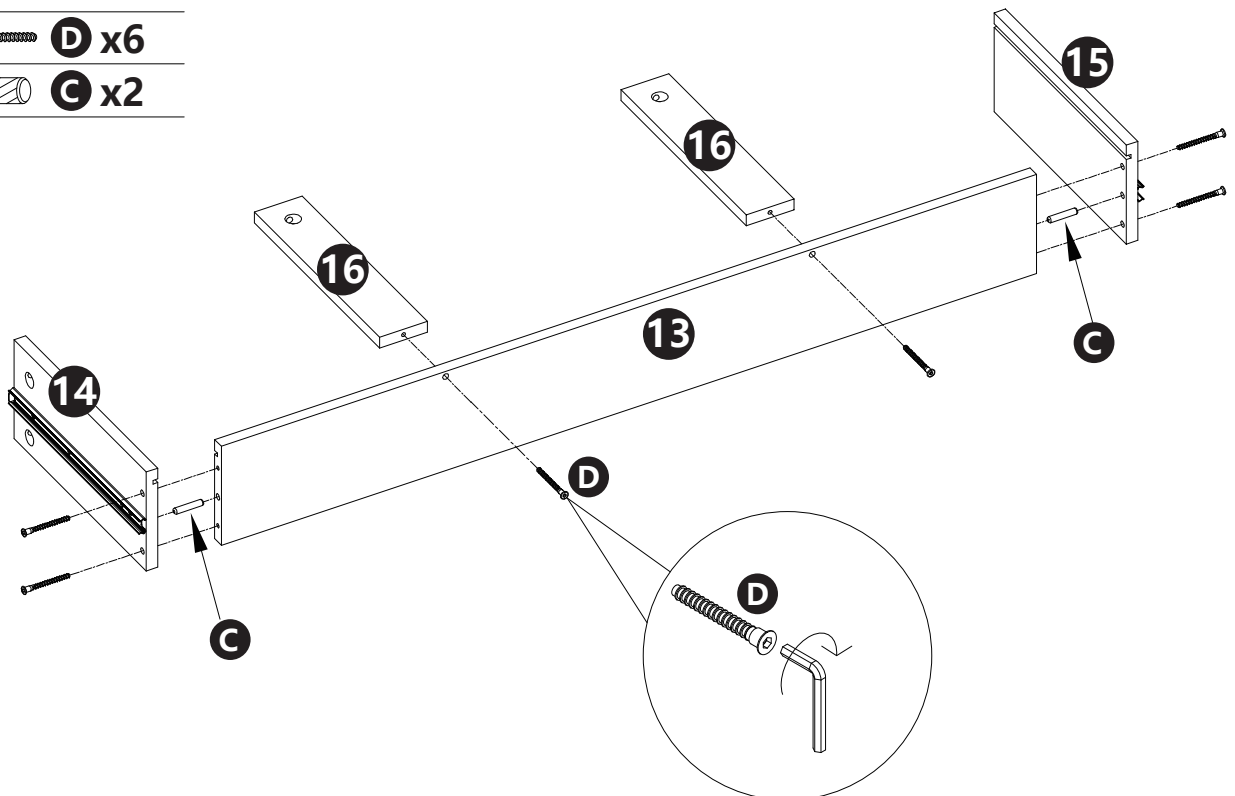

**STEP 18**

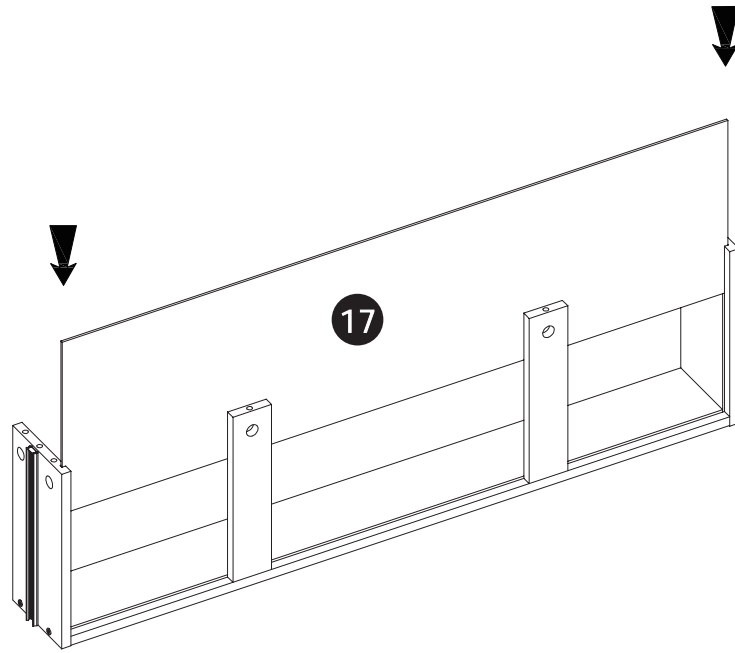

**STEP 19**

 **B** x6

 **A** x6

 **C** x2

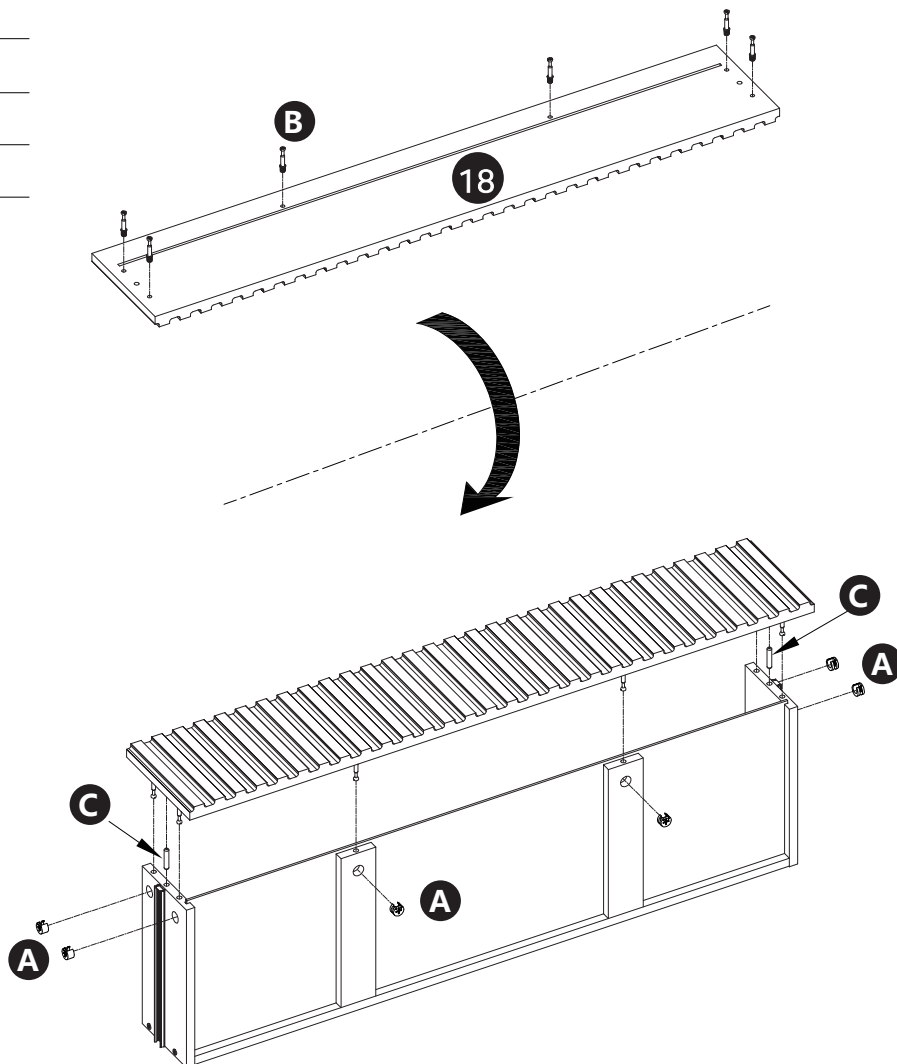

## STEP 20

Install the inner fixing rails on the drawer, while ensuring that the left and right slide rails are in the same horizontal position. Note that the left and right sides of the middle rail and the outer rail are not kept level, and this time there may be a case of jamming and not pushing into the case. At this time, you need to check the position of the outer rail or adjust the inner rail to meet the position of the outer rail, can not push and pull violently, should slowly pull the drawer to try, if there is a problem, you need to readjust.

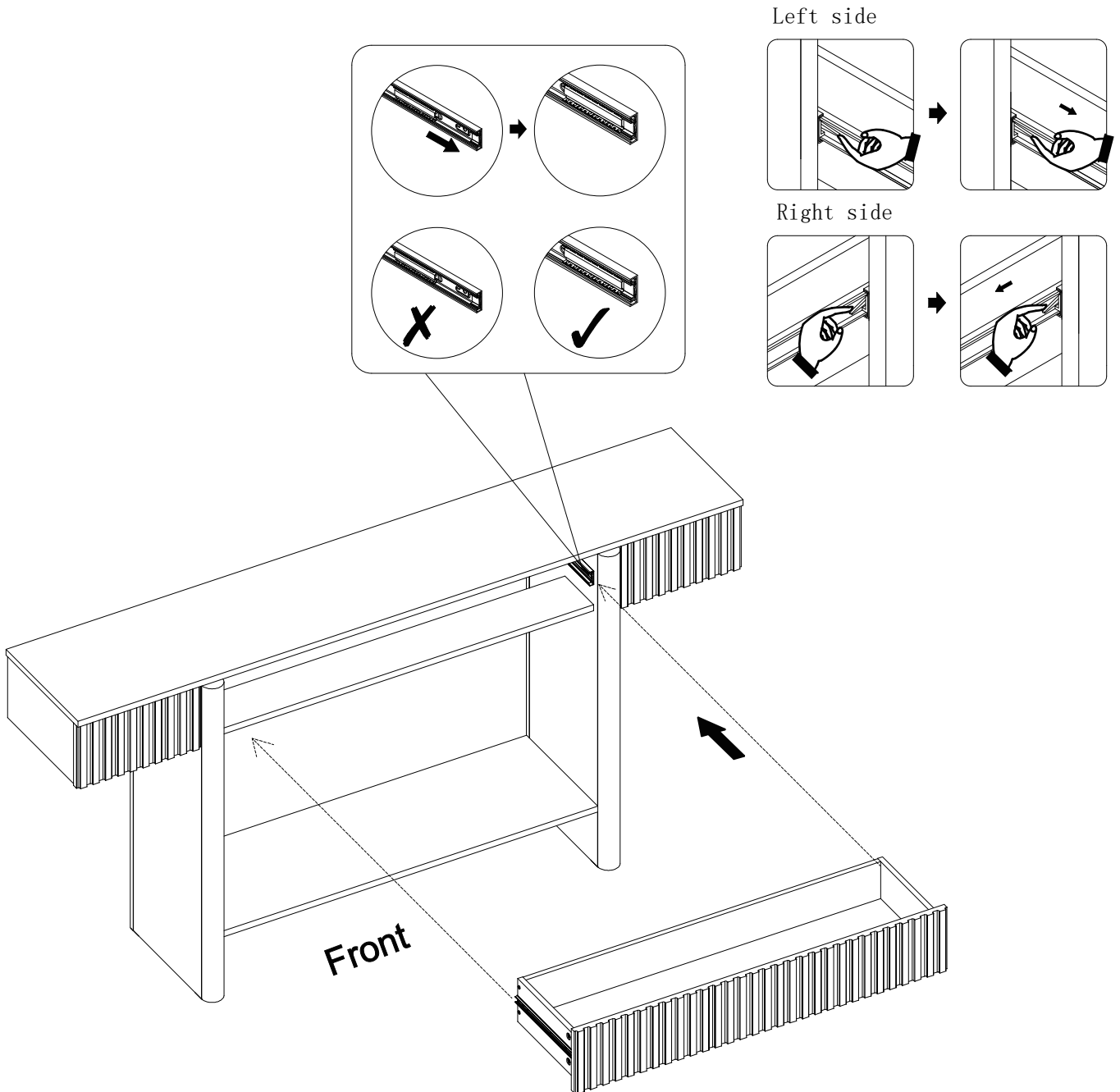

**STEP 21**



Drill a hole in the wall , then hammer the I1 into the wall with a hammer

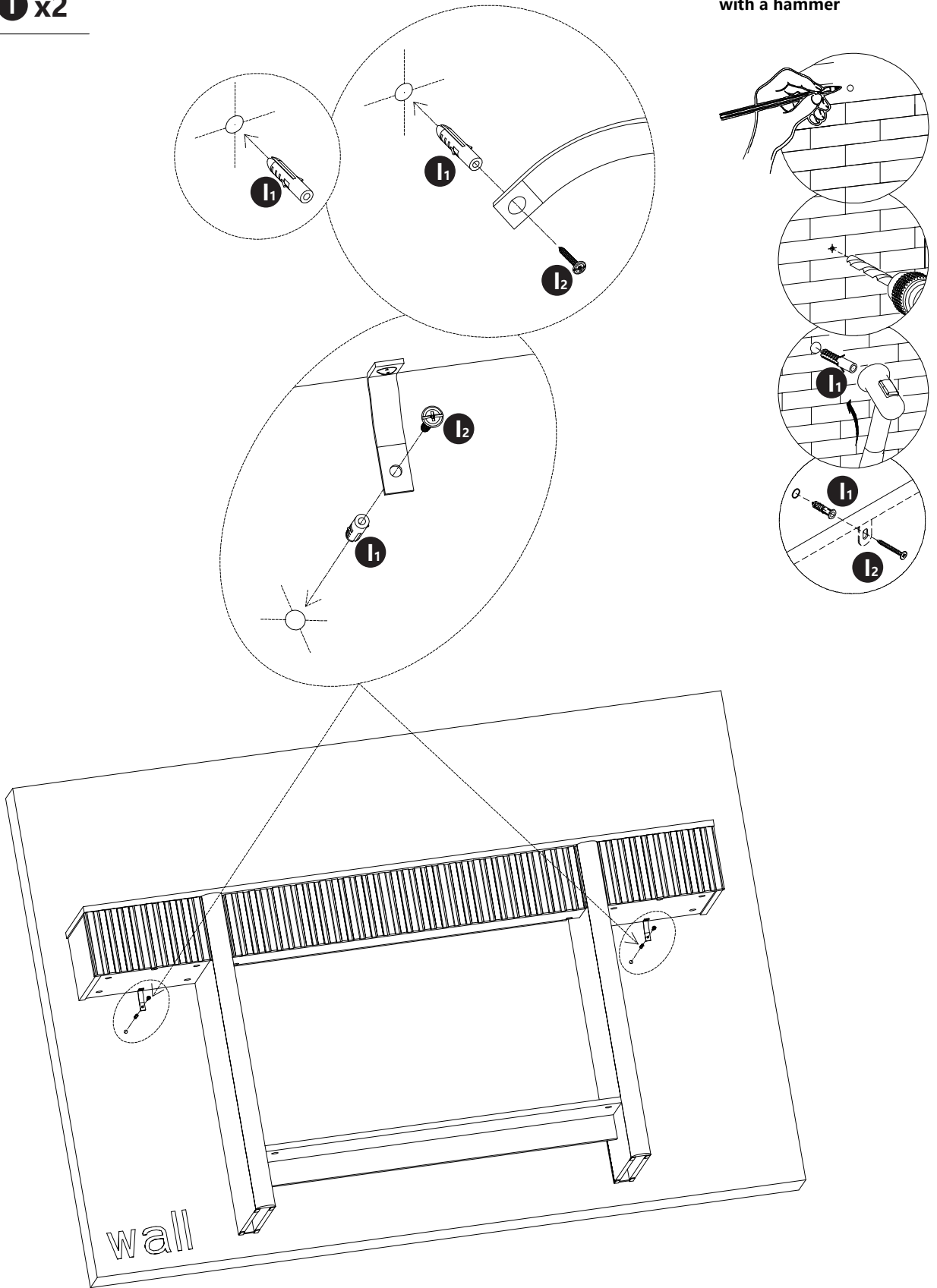

STEP 22

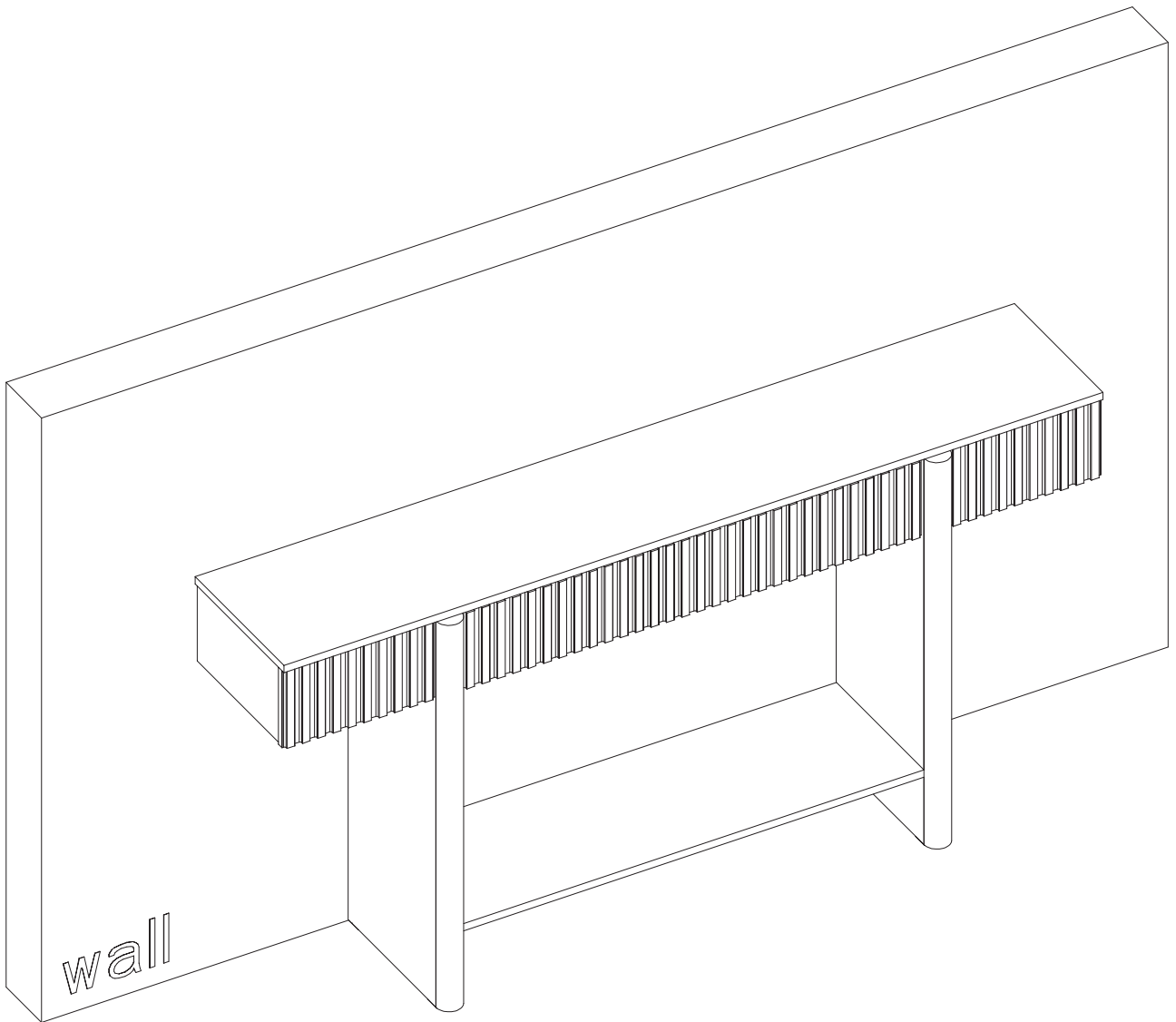

# UN

## GENERAL GUIDELINES

- Please read the following instructions carefully and use the product accordingly.
- Please keep this instruction and hand it over when you transfer the product.
- This summary may not include every detail of all variations and considered steps.
- Please contact us when further information and help are needed.

## NOTES

- The product is intended for normal use only. The seller does not assume any responsibility or liability with respect to any damage caused by incorrect assembly or improper use.
- Keep away from exposure and heat sources. Place it in a dry area to avoid peeling or fading.
- Please check if there is any welding spatter or debris when you receive the product. If there are defective or missing parts after unpacking, please contact us immediately. Use soft cloth and neutral detergent to wipe it clean, then wipe dry. Do not use an abrasive agent to wipe the product.

## WARNINGS

- During assembly, keep small parts out of the reach of children. It may be fatal if swallowed or inhaled.
- To avoid potential danger of suffocation, keep all parts and packaging (films, plastic bags and foam, etc.) away from babies and children.
- Keep away from sharp or corrosive items to avoid potential product damage or bodily injury.

# GE

## EINLEITUNG

- Bitte lesen Sie die folgende Anleitung aufmerksam durch und verwenden Sie das Produkt sachgemäß.
- Bewahren Sie diese Anleitung gut auf und händigen Sie sie bei Weitergabe des Produkts an Dritte ebenfalls mit aus.
- Aus Gründen der Übersicht können nicht alle Details zu allen Varianten und denkbaren Montagen beschrieben werden. Wenn Sie weitere Informationen und Hilfe benötigen, kontaktieren Sie uns bitte.

## HINWEISE

- Das Produkt ist nur für die Verwendung im Innenbereich vorgesehen. Montieren und verwenden Sie das Produkt nur wie in dieser Anleitung beschrieben. Eine andere Verwendung als beschrieben, oder eine Veränderung/ein Umbau des Produkts ist nicht erlaubt und kann zu Verletzungen und/oder Beschädigungen des Produkts führen. Der Händler übernimmt keine Haftung für Schäden, die durch unsachgemäßen Gebrauch oder falsche Montage entstanden sind. Nach Erhalt des Produkts überprüfen Sie es bitte, und stellen Sie sicher, dass kein Schweißschlacke oder Splitter vorhanden ist.
- Das Produkt darf nicht benutzt werden, wenn Teile beschädigt sind oder fehlen. Ansonsten könnten Schäden entstehen.
- Beim Zusammenbauen schrauben Sie bitte zuerst alle Schrauben nicht fest an, erst nach dem Aufbau ziehen Sie sie fest an.
- Bitte überprüfen Sie regelmäßig den Zustand der Schraubenbefestigung, da es das Risiko gibt, dass einige Schrauben beim Gebrauch gelöst werden. Stellen Sie sicher, dass alle Schrauben immer fest sind, um ein Umkippen beim Gebrauch zu vermeiden.

## WARNHINWEIS

- Halten Sie Kinder während der Montage vom Arbeitsbereich fern. Zum Lieferumfang gehören eine Vielzahl von Schrauben und anderen Kleinteilen. Diese können beim Verschlucken oder Inhalieren lebensgefährlich sein.
- Lassen Sie keine Kinder auf den Artikel klettern, oder an dem Artikel spielen, um die Umkipppgefahr zu vermeiden.
- Zur Vermeidung der Erstickungsgefahr halten Sie die Verpackungsmaterialien wie Kunststoff-Verpackungstüten von Babys und Kindern fern.
- Vermeiden Sie generell jeden Kontakt mit spitzen Gegenständen und aggressiven Substanzen, um das Produkt vor Beschädigung zu schützen, und seine Sicherheit zu schützen.

**FR**

## INTRODUCTION

- Lisez attentivement ces notes et utilisez votre produit conformément au présent mode d'emploi.
- Obéissez à ces instructions. Si vous voulez mettre ce produit à la disposition de tiers, veuillez joindre ce mode d'emploi.
- Par souci de clarté, les détails concernant chaque variante ou montage envisageable ne peuvent être tous décrits.
- Si vous avez besoin de plus d'informations ou si vous rencontrez certains problèmes non traités de manière détaillée dans ces instructions, veuillez nous contacter.

## NOTES

- Le produit doit être installé et utilisé conformément à ce mode d'emploi. Les utilisations qui ne correspondent pas à la description ci-dessus ou les modifications de l'article ne sont pas autorisées. Le vendeur n'est responsable d'aucun dommage résultant de l'installation incorrecte ou de l'utilisation non conforme.
- Veuillez vérifier attentivement avant l'installation pour vous assurer qu'il n'y a pas de résidus de soudure ou de débris.
- Il est interdit d'utiliser des produits endommagés ou perdus, sinon, il y aura un risque de blessure.
- Lors de l'installation, veuillez positionner et ajuster correctement toutes les vis et les écrous, ensuite serrez progressivement l'ensemble des vis.
- Il est recommandé d'examiner périodiquement les vis qui pourraient se relâcher progressivement pendant l'utilisation, ce qui risque de provoquer des dommages causés par un renversement du produit. Veuillez donc à vous assurer que les vis sont bien serrées.
- Pour l'entretien quotidien, utilisez un chiffon doux et sec. Si nécessaire, vous pouvez utiliser un produit détergent à pH neutre. Ne jamais essuyer la surface avec un chiffon mouillé ou un matériau dur..

## AVERTISSEMENTS

- Il est interdit aux enfants de participer à l'assemblage du produit car il comprend de nombreuses petites pièces et l'aspiration ou l'ingestion de ces pièces présente un risque mortel.
- Pour éviter le danger inattendu (par exemple, asphyxie), éloignez les enfants de tous.
- les composants et emballages (films, sac en plastique, polystyrènes, etc.) . Eloignez les objets aigus ou corrosifs du produit afin d'éviter les dommages possibles.

**IT**

## LINEE GUIDA GENERALI

- Leggere attentamente le seguenti istruzioni e usare il prodotto in modo opportuno.
- Conservare questo manuale e consegnarlo quando il prodotto cambia proprietario.
- Questo estratto potrebbe non includere ogni dettaglio di tutte le modifiche e le fasi considerate. Contattarci se hai bisogno di ulteriori informazioni e assistenza.

## NOTE

- Il venditore non si assume alcuna responsabilità per quanto riguarda danni causati da montaggio scorretto o uso improprio.
- Controllare che non ci siano schizzi o residui di saldatura quando ricevi il prodotto.
- Nel caso in cui ci siano parti difettose o mancanti, contattare immediatamente l'assistenza clienti.
- Durante il processo di assemblaggio, serrare a metà le viti fino a quando il telaio non è completo, quindi serrarle completamente.
- Pulire con un panno morbido e un detergente neutrale e asciugare con un panno asciutto. Non utilizzare detersivi abrasivi per pulire il prodotto.

## AVVERTENZE

- Durante l'assemblaggio, tenere le parti di piccole dimensioni lontano dai bambini. Potrebbero essere letali in caso di ingestione o inalazione.
- Tenere tutte le componenti e i materiali d'imballaggio (pellicole, sacchetti di plastica, polistirolo, ecc.) lontani dai bambini per prevenire il rischio di soffocamento. Tenere lontano da oggetti appuntiti o corrosivi per evitare potenziali danni al prodotto o lesioni.

# SP

## ACERCA DEL MANUAL

- Por favor, lea detenidamente las instrucciones y respete los debidos usos del producto.
- Por favor, conserve bien este manual y en caso de cesión, no olvide entregarlo junto con el producto.
- No es posible que se presenten todos los detalles y pasos de montaje en las instrucciones. Si necesita ayuda o información adicional, póngase en contacto con nosotros.

## NOTAS

- Ha de montarse y utilizarse el producto paso a paso siguiendo estrictamente las instrucciones.
- De lo contrario, el vendedor no asumirá ninguna responsabilidad por los daños y lesiones causados por el montaje y los usos inadecuados.
- Después de recibir el producto, por favor compruebe atentamente para asegurar que no haya desechos de soldaduras ni pedacitos.
- Si hay las piezas perdidas o dañadas, no utilice el producto, de lo contrario, existirá el peligro de lesiones.
- No apriete totalmente ningún tornillo durante el montaje, una vez terminado el montaje, apriete completamente todos los tornillos.
- Inspeccione regularmente los tornillos. Durante el uso, los tornillos se podrán aflojar, causará daños al producto, por eso asegure que todos los tornillos estén bien apretados.

## ADVERTENCIAS

- Debido a que existen múltiples tornillos y otras piezas pequeñas, no permita que se acerquen los niños por el riesgo de asfixia producida por tragar alguna pieza.
- Guarde el embalaje fuera del alcance de los niños para evitar el peligro de asfixia.
- No deje que el producto conecte con los objetos puntiagudos ni los productos químicos para evitar causar daños o lesiones.

# EN

## GENERAL GUIDELINES

- Please read the following instructions carefully and use the product accordingly.
- Please keep this instruction and hand it over when you transfer the product.
- This summary may not include every detail of all variations and considered steps.
- Please contact us when further information and help are needed.

## NOTES

- The product is intended for normal use only. The seller does not assume any responsibility or liability with respect to any damage caused by incorrect assembly or improper use.
- Keep away from exposure and heat sources. Place it in a dry area to avoid peeling or fading.
- Please check if there is any welding spatter or debris when you receive the product.
- If there are defective or missing parts after unpacking, please contact us immediately. Use soft cloth and neutral detergent to wipe it clean, then wipe dry. Do not use an abrasive agent to wipe the product.

## WARNINGS

- During assembly, keep small parts out of the reach of children. It may be fatal if swallowed or inhaled.
- To avoid potential danger of suffocation, keep all parts and packaging (films, plastic bags and foam, etc.) away from babies and children.
- Keep away from sharp or corrosive items to avoid potential product damage or bodily injury.